

Enhancement Mode pHEMT Technology (E-pHEMT)

Low Noise Amplifier

The MML09212H is a 2-stage low noise amplifier (LNA) with active bias and high isolation for use in cellular infrastructure applications. It is designed for a range of low noise, high linearity applications such as picocell, femtocell, tower mounted amplifiers (TMA) and receiver front-end circuits. It operates from a single voltage supply and is suitable for applications with frequencies from 400 to 1400 MHz such as ISM, GSM, W-CDMA and LTE.

Features

- Low noise figure: 0.52 dB @ 900 MHz
- Frequency: 400–1400 MHz
- Unconditionally stable over temperature
- High reverse isolation: -58 dB @ 900 MHz
- P1dB: 22.8 dBm @ 900 MHz
- Small-signal gain: 37.5 dB @ 900 MHz
- Third order output intercept point: 37.5 dBm @ 900 MHz
- Active bias control (on-chip)
- Single 5 V supply
- Supply current: 150 mA
- 50 ohm operation (some external matching required)
- Cost-effective 12-pin, 3 mm QFN surface mount plastic package

MML09212HT1

**400–1400 MHz, 37.5 dB, 22.8 dBm
E-pHEMT LNA**



QFN 3 x 3-12L

Table 1. Typical Performance (1)

Characteristic	Symbol	400 MHz	900 MHz	1400 MHz	Unit
Noise Figure (2)	NF	0.52	0.52	0.74	dB
Input Return Loss (S11)	IRL	-19	-24	-17	dB
Output Return Loss (S22)	ORL	-15	-14	-13.5	dB
Small-Signal Gain (S21)	G _p	40.0	37.5	35.0	dB
Power Output @ 1dB Compression	P1dB	22.6	22.8	22.5	dBm
Third Order Input Intercept Point	IIP3	-2	-0.5	3	dBm
Third Order Output Intercept Point	OIP3	37	37	38	dBm

1. V_{DD} = 5 Vdc, T_A = 25°C, 50 ohm system, application circuit tuned for specified frequency.

2. Noise figure value calculated with connector losses removed.

Table 2. Maximum Ratings

Rating	Symbol	Value	Unit
Supply Voltage	V _{DD}	6	V
Supply Current	I _{DD}	300	mA
RF Input Power	P _{in}	20	dBm
Storage Temperature Range	T _{stg}	-65 to +150	°C
Junction Temperature	T _J	175	°C

Table 3. Thermal Characteristics

Characteristic	Symbol	Value (3)	Unit
Thermal Resistance, Junction to Case Case Temperature 83°C, 5 Vdc, 150 mA, no RF applied	R _{θJC}	37	°C/W

3. Refer to AN1955, *Thermal Measurement Methodology of RF Power Amplifiers*. Go to <http://www.nxp.com/RE> and search for AN1955.

Table 4. Electrical Characteristics ($V_{DD} = 5$ Vdc, 900 MHz, $T_A = 25^\circ\text{C}$, 50 ohm system, in NXP Application Circuit)

Characteristic	Symbol	Min	Typ	Max	Unit
Small-Signal Gain (S21)	G_p	35.0	37.5	—	dB
Input Return Loss (S11)	IRL	—	-24	—	dB
Output Return Loss (S22)	ORL	—	-14	—	dB
Power Output @ 1dB Compression	P1dB	—	22.8	—	dBm
Third Order Input Intercept Point	IIP3	—	-0.5	—	dBm
Third Order Output Intercept Point	OIP3	—	37	—	dBm
Reverse Isolation (S12)	S12	—	-58	—	dBm
Noise Figure (1)	NF	—	0.52	—	dB
Supply Current (2)	I_{DD}	128	150	178	mA
Supply Voltage	V_{DD}	—	5	—	V

Table 5. ESD Protection Characteristics

Test Methodology	Class
Human Body Model (per JESD22-A114)	0
Machine Model (per EIA/JESD22-A115)	A
Charge Device Model (per JESD22-C101)	IV

Table 6. Moisture Sensitivity Level

Test Methodology	Rating	Package Peak Temperature	Unit
Per JESD22-A113, IPC/JEDEC J-STD-020	1	260	$^\circ\text{C}$

Table 7. Ordering Information

Device	Tape and Reel Information	Package
MML09212HT1	T1 Suffix = 1,000 Units, 12 mm Tape Width, 7-inch Reel	QFN 3 × 3–12L

- Noise figure value calculated with connector losses removed.
- DC current measured with no RF signal applied.

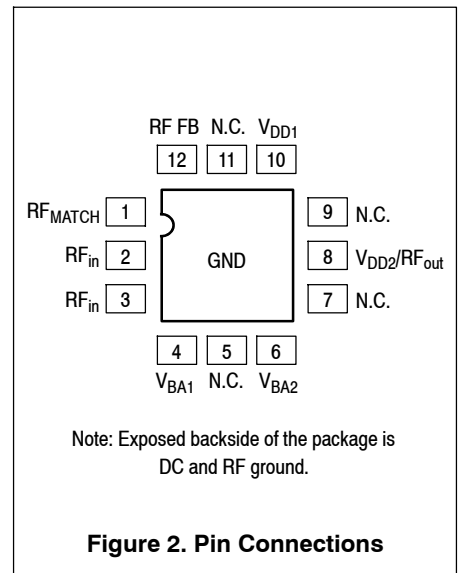
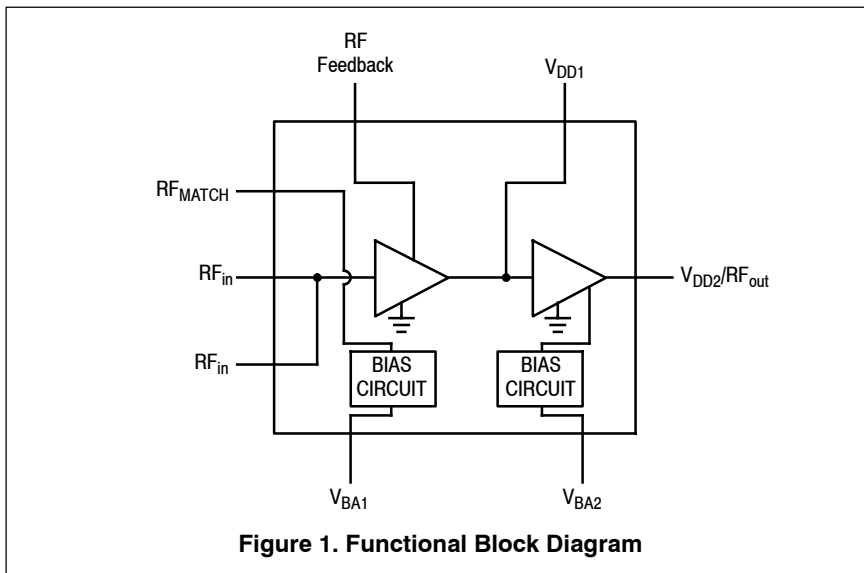

50 OHM APPLICATION CIRCUIT: 900 MHz

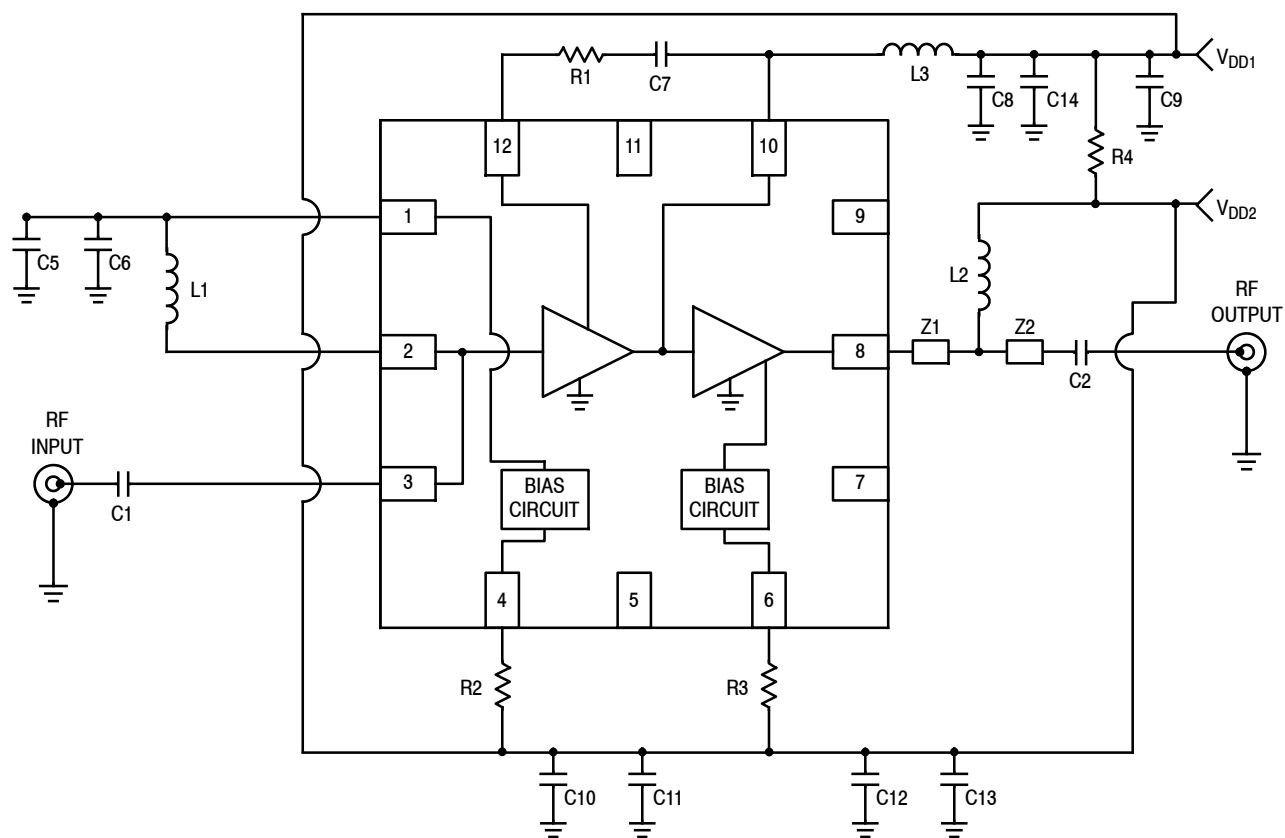

Z1 0.050" × 0.021" Microstrip
 Z2 0.030" × 0.021" Microstrip

Figure 3. MML09212HT1 Test Circuit Schematic

Table 8. MML09212HT1 Test Circuit Component Designations and Values

Part	Description	Part Number	Manufacturer
C1, C2, C7, C14	56 pF Chip Capacitors	GRM1555C1H560JZ01	Murata
C3, C4	Components Not Placed		
C5	180 pF Chip Capacitor	GRM1555C1H181JZ01	Murata
C6, C9, C10, C13	0.01 μF Chip Capacitors	GRM155R71E103KA01	Murata
C8	1000 pF Chip Capacitor	GRM155R71E101KA01	Murata
C11, C12	100 pF Chip Capacitors	GRM1555C1H101JZ01	Murata
L1	12 nH Chip Inductor	0402CS-12NXGL	Coilcraft
L2	30 nH Chip Inductor	0402CS-30NXGL	Coilcraft
L3	8.2 nH Chip Inductor	0402CS-8N2XGL	Coilcraft
R1	82 Ω Chip Resistor	RC0402JR-07-82RL	Yageo
R2	1100 Ω Chip Resistor	RC0402FR-07-1K1L	Yageo
R3	910 Ω Chip Resistor	RC0402FR-07-910RL	Yageo
R4	0 Ω, 1 A Chip Resistor	ERJ2GE0R00X	Panasonic
PCB	0.010", ε _r = 3.48, Multilayer	RO4350B	Rogers

Note: Component numbers C3 and C4 are labeled on board but not placed.

50 OHM APPLICATION CIRCUIT: 900 MHz

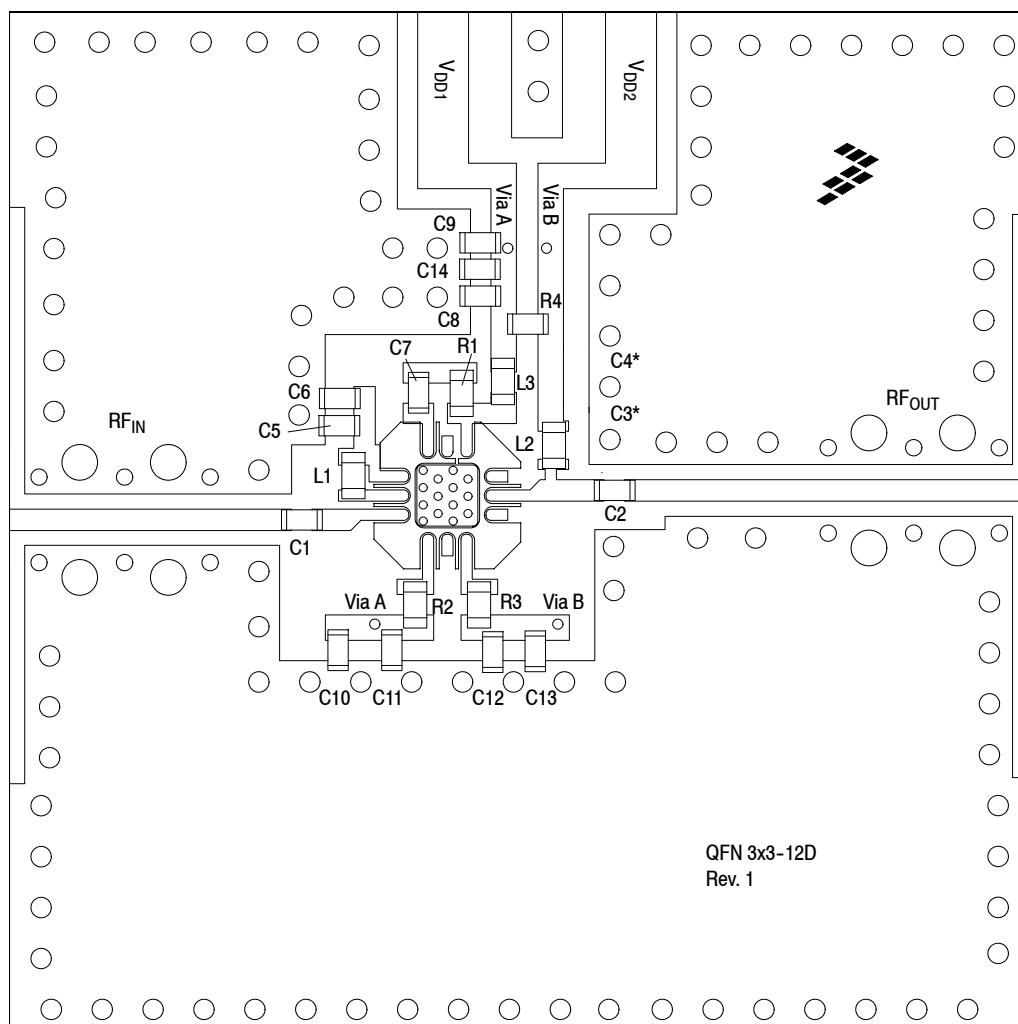

Note: Component numbers C3* and C4* are labeled on board but not placed.

Figure 4. MML09212HT1 Test Circuit Component Layout

Table 8. MML09212HT1 Test Circuit Component Designations and Values

Part	Description	Part Number	Manufacturer
C1, C2, C7, C14	56 pF Chip Capacitors	GRM1555C1H560JZ01	Murata
C3, C4	Components Not Placed		
C5	180 pF Chip Capacitor	GRM1555C1H181JZ01	Murata
C6, C9, C10, C13	0.01 μ F Chip Capacitors	GRM155R71E103KA01	Murata
C8	1000 pF Chip Capacitor	GRM155R71E101KA01	Murata
C11, C12	100 pF Chip Capacitors	GRM1555C1H101JZ01	Murata
L1	12 nH Chip Inductor	0402CS-12NXGL	Coilcraft
L2	30 nH Chip Inductor	0402CS-30NXGL	Coilcraft
L3	8.2 nH Chip Inductor	0402CS-8N2XGL	Coilcraft
R1	82 Ω Chip Resistor	RC0402JR-07-82RL	Yageo
R2	1100 Ω Chip Resistor	RC0402FR-07-1K1L	Yageo
R3	910 Ω Chip Resistor	RC0402FR-07-910RL	Yageo
R4	0 Ω , 1 A Chip Resistor	ERJ2GE0R00X	Panasonic
PCB	0.010", $\epsilon_r = 3.48$, Multilayer	RO4350B	Rogers

(Test Circuit Component Designations and Values repeated for reference.)

50 OHM TYPICAL CHARACTERISTICS: 900 MHz

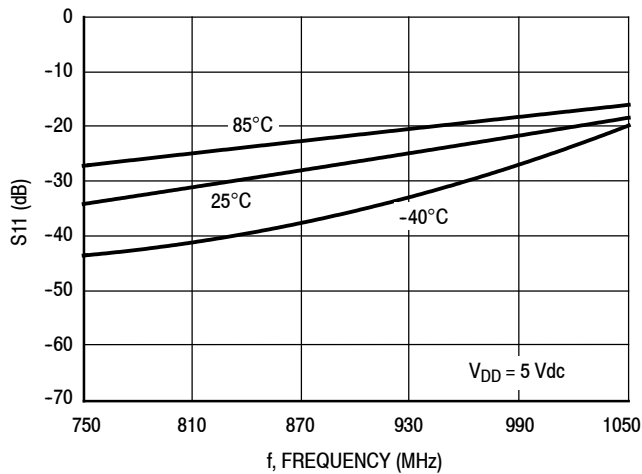

Figure 5. S11 versus Frequency versus Temperature

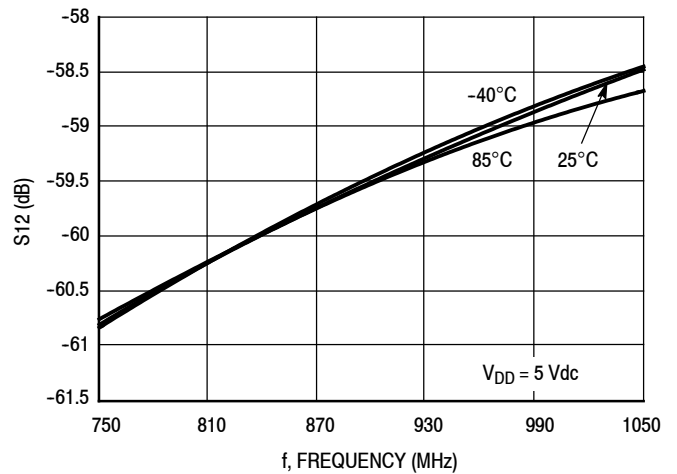

Figure 6. S12 versus Frequency versus Temperature

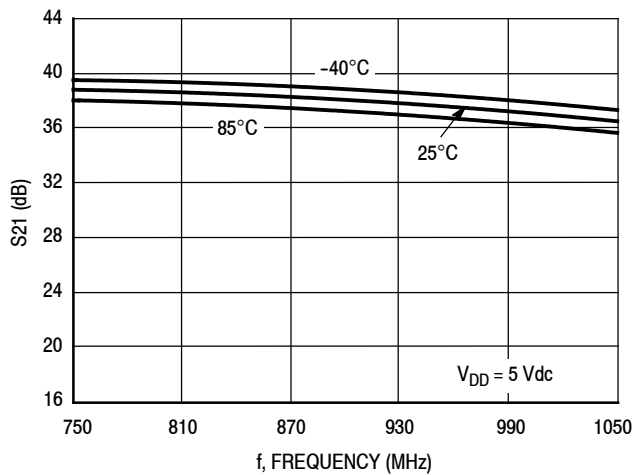

Figure 7. S21 versus Frequency versus Temperature

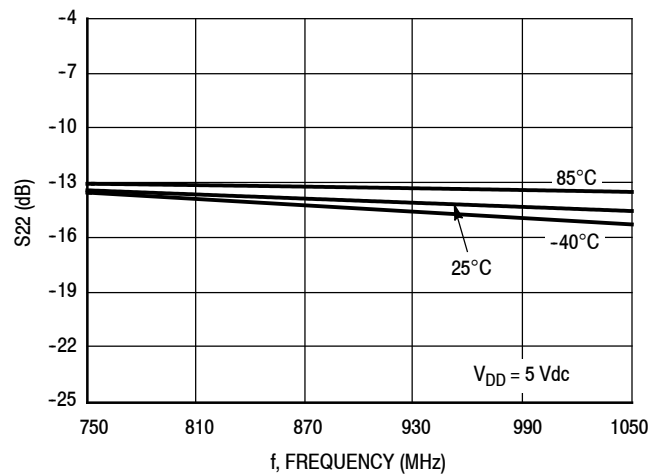

Figure 8. S22 versus Frequency versus Temperature

50 OHM TYPICAL CHARACTERISTICS: 900 MHz

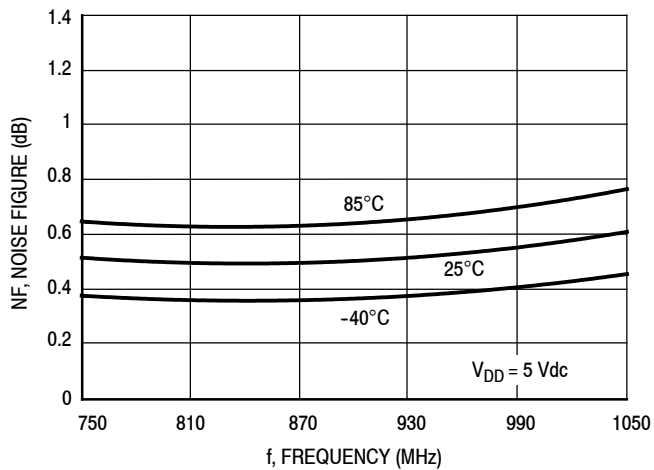

Figure 9. Noise Figure versus Frequency versus Temperature

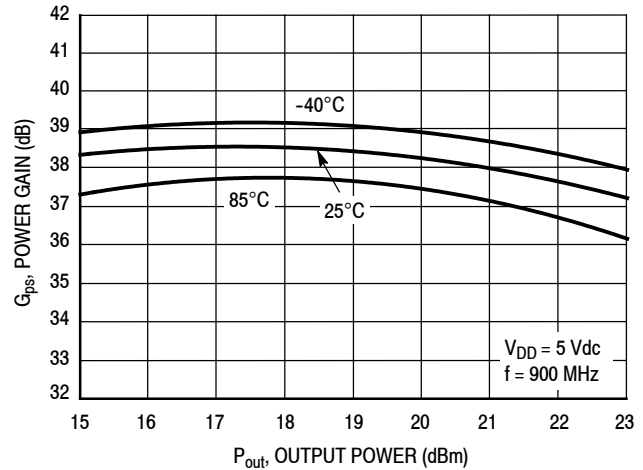

Figure 10. Power Gain versus Output Power versus Temperature, CW

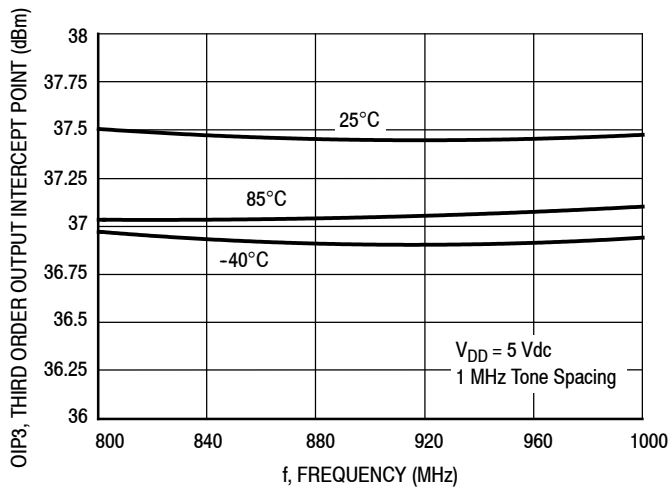

Figure 11. Third Order Output Intercept Point (Two-Tone) versus Frequency versus Temperature

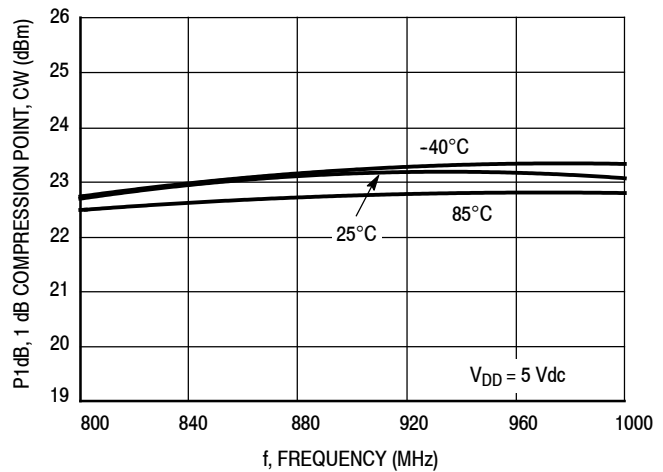
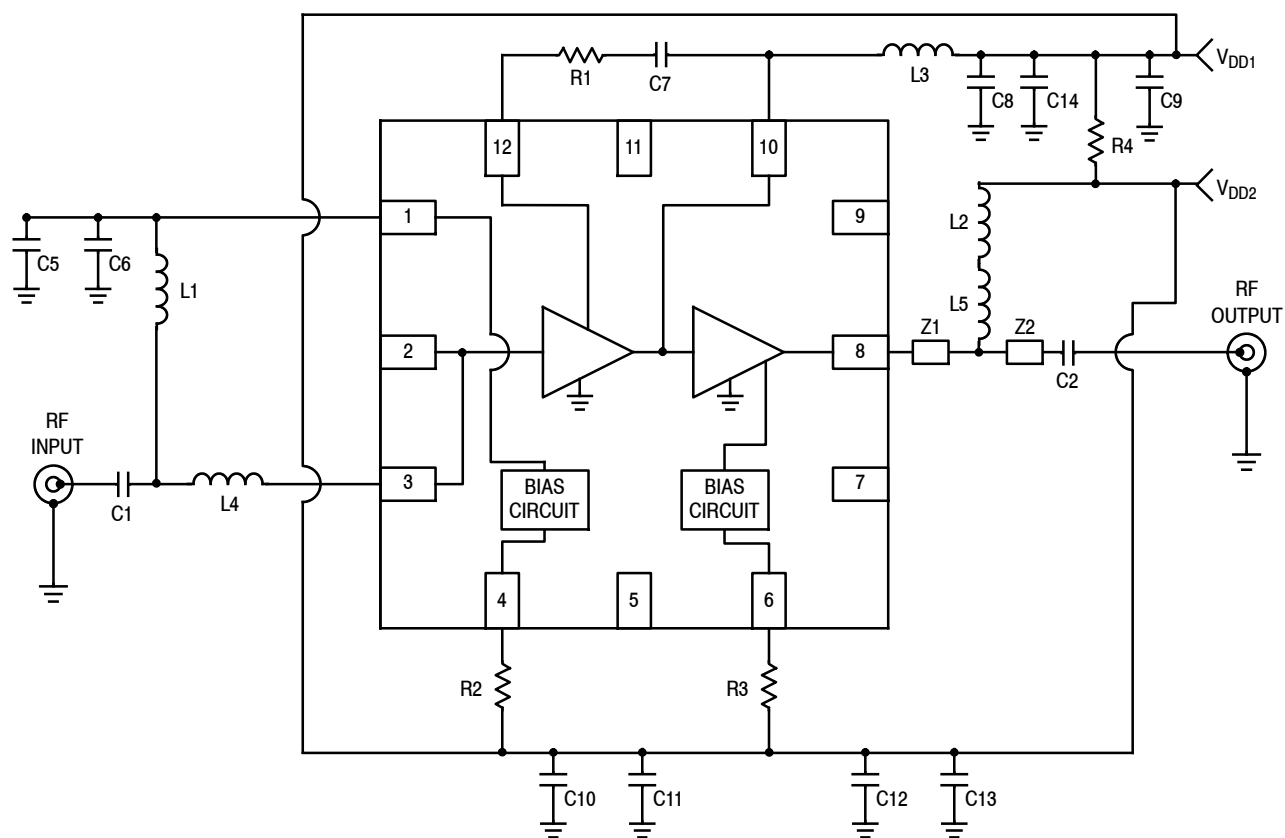

Figure 12. P1dB versus Frequency versus Temperature, CW

50 OHM APPLICATION CIRCUIT: 400 MHz



Z1 0.050" × 0.021" Microstrip
 Z2 0.030" × 0.021" Microstrip

Figure 13. MML09212HT1 Test Circuit Schematic

Table 9. MML09212HT1 Test Circuit Component Designations and Values

Part	Description	Part Number	Manufacturer
C1, C2	100 pF Chip Capacitors	GRM1555C1H101JZ01	Murata
C3, C4	Components Not Placed		
C5, C7, C8, C11, C12	390 pF Chip Capacitors	GRM1555C1H391JZ01	Murata
C6, C9, C10, C13	0.01 μF Chip Capacitors	GRM155R71E103KA01	Murata
C14	1000 pF Chip Capacitor	GRM155R71E101KA01	Murata
L1	20 nH Chip Inductor	0402CS-20NXGL	Coilcraft
L2, L5	30 nH Chip Inductors	0402CS-30NXGL	Coilcraft
L3	16 nH Chip Inductor	0402CS-16NNXGL	Coilcraft
L4	1.2 nH Chip Inductor	0402CS-1N2XJL	Coilcraft
R1	100 Ω Chip Resistor	RC0402JR-07-100RL	Yageo
R2	1100 Ω Chip Resistor	RC0402FR-07-1K1L	Yageo
R3	910 Ω Chip Resistor	RC0402FR-07-910RL	Yageo
R4	0 Ω, 1 A Chip Resistor	ERJ2GE0R00X	Panasonic
PCB	0.010", ε _r = 3.48, Multilayer	RO4350B	Rogers

Note: Component numbers C3 and C4 are labeled on board but not placed.

50 OHM APPLICATION CIRCUIT: 400 MHz

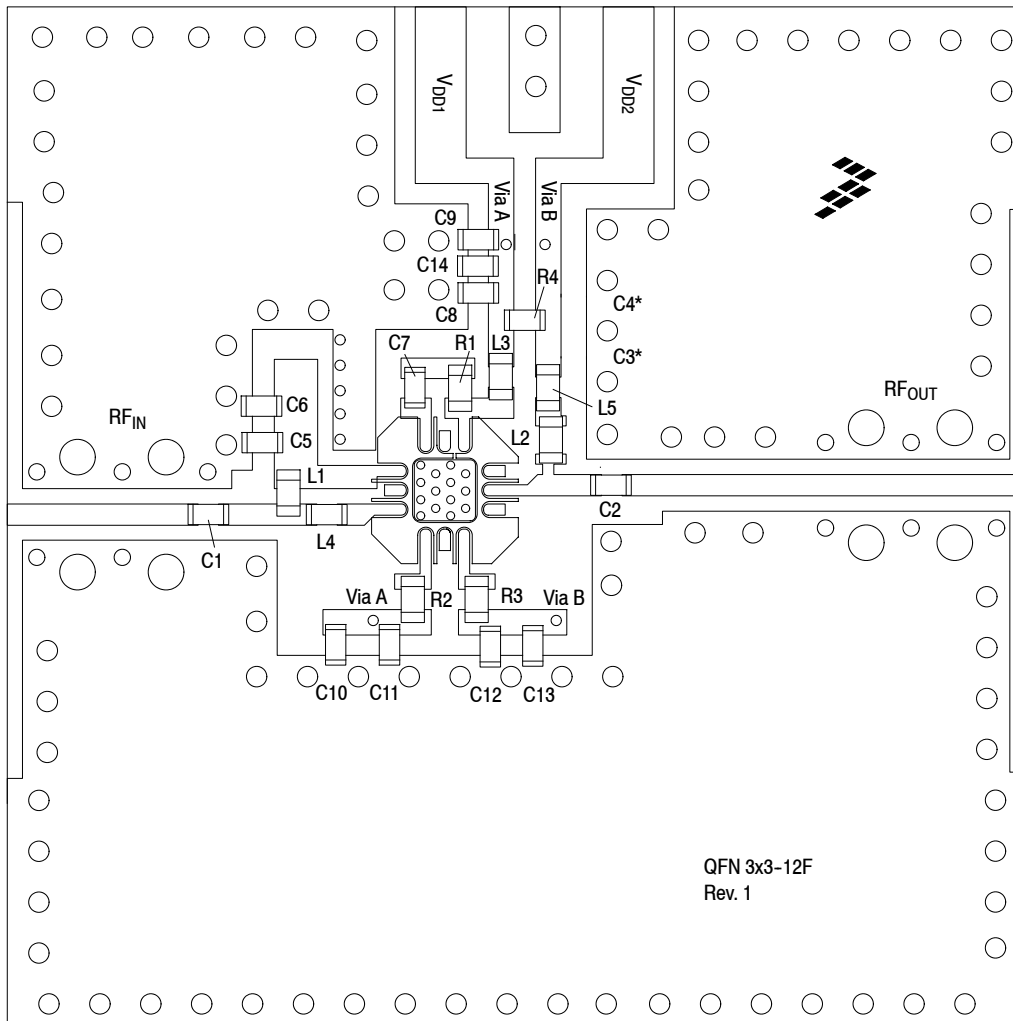

Note: Component numbers C3* and C4* are labeled on board but not placed.

Figure 14. MML09212HT1 Test Circuit Component Layout

Table 9. MML09212HT1 Test Circuit Component Designations and Values

Part	Description	Part Number	Manufacturer
C1, C2	100 pF Chip Capacitors	GRM1555C1H101JZ01	Murata
C3, C4	Components Not Placed		
C5, C7, C8, C11, C12	390 pF Chip Capacitors	GRM1555C1H391JZ01	Murata
C6, C9, C10, C13	0.01 μ F Chip Capacitors	GRM155R71E103KA01	Murata
C14	1000 pF Chip Capacitor	GRM155R71E101KA01	Murata
L1	20 nH Chip Inductor	0402CS-20NXGL	Coilcraft
L2, L5	30 nH Chip Inductors	0402CS-30NXGL	Coilcraft
L3	16 nH Chip Inductor	0402CS-16NNXGL	Coilcraft
L4	1.2 nH Chip Inductor	0402CS-1N2XJL	Coilcraft
R1	100 Ω Chip Resistor	RC0402JR-07-100RL	Yageo
R2	1100 Ω Chip Resistor	RC0402FR-07-1K1L	Yageo
R3	910 Ω Chip Resistor	RC0402FR-07-910RL	Yageo
R4	0 Ω , 1 A Chip Resistor	ERJ2GE0R00X	Panasonic
PCB	0.010", $\epsilon_r = 3.48$, Multilayer	RO4350B	Rogers

(Test Circuit Component Designations and Values repeated for reference.)

MML09212HT1

50 OHM TYPICAL CHARACTERISTICS: 400 MHz

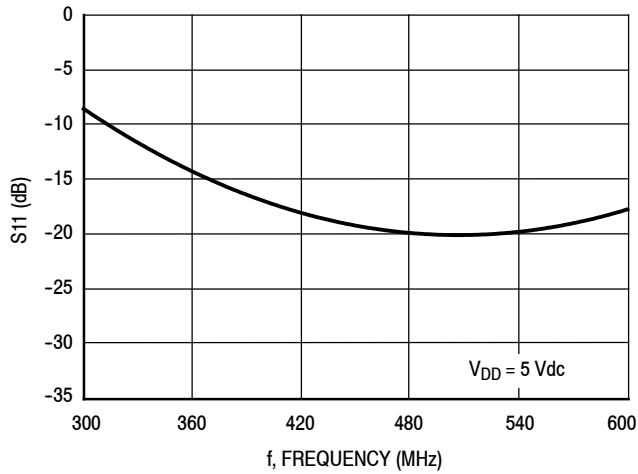

Figure 15. S11 versus Frequency

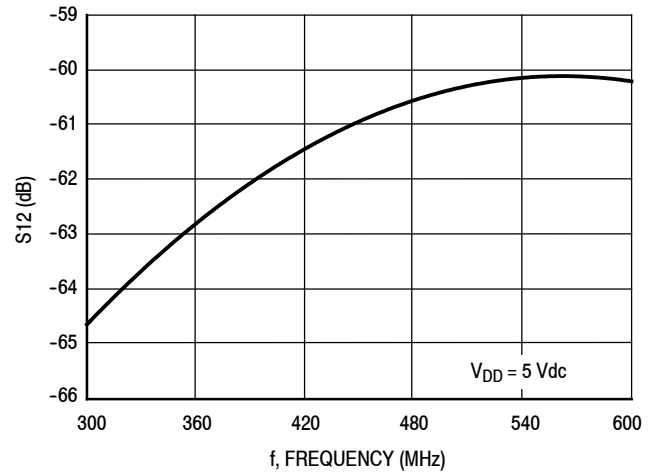

Figure 16. S12 versus Frequency

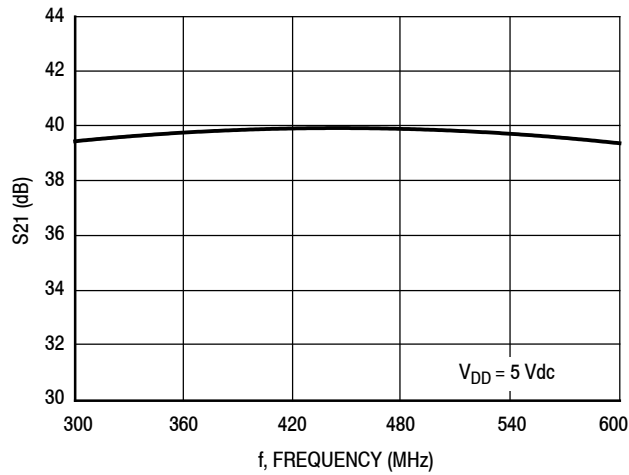

Figure 17. S21 versus Frequency

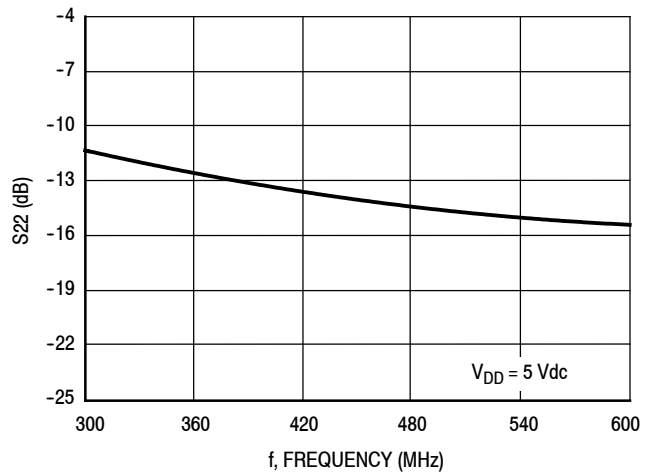

Figure 18. S22 versus Frequency

50 OHM TYPICAL CHARACTERISTICS: 400 MHz

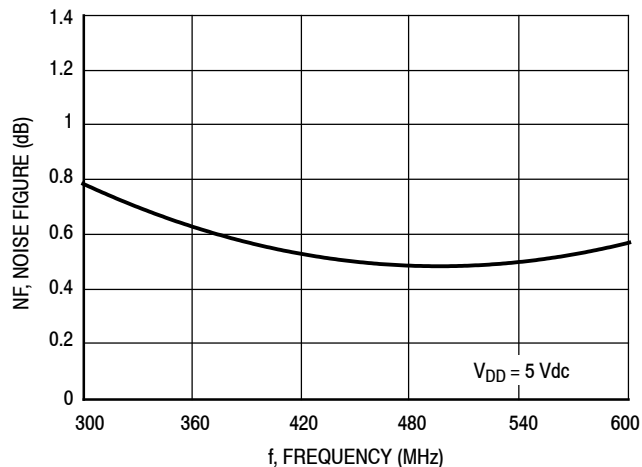

Figure 19. Noise Figure versus Frequency

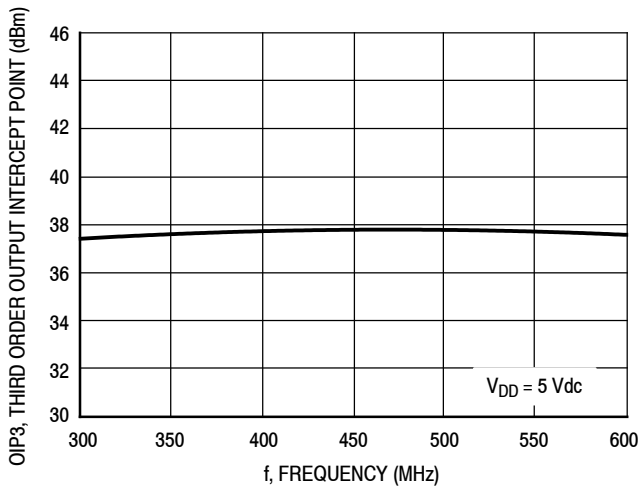
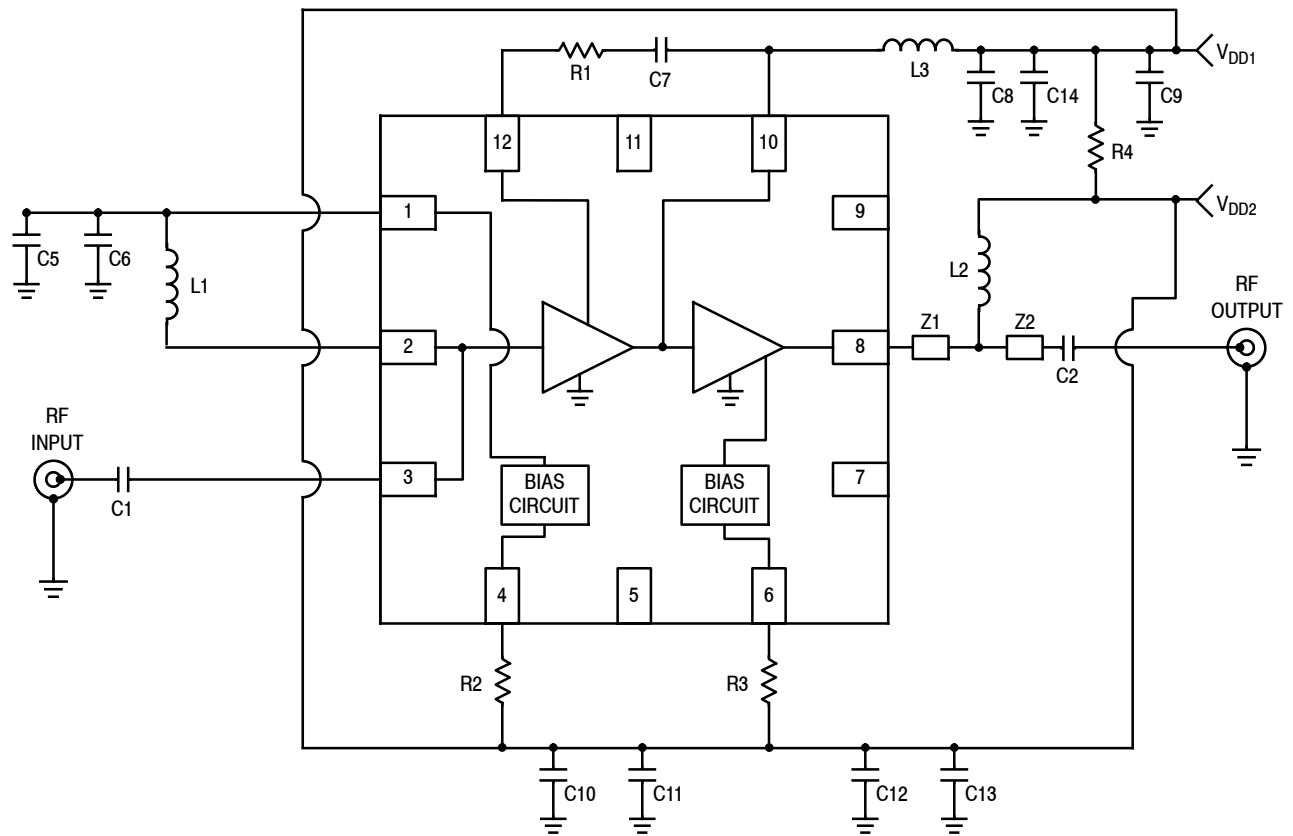

Figure 20. Third Order Output Intercept Point (Two-Tone) versus Frequency

50 OHM APPLICATION CIRCUIT: 1400 MHz



Z1 0.050" × 0.021" Microstrip
 Z2 0.030" × 0.021" Microstrip

Figure 21. MML09212HT1 Test Circuit Schematic

Table 10. MML09212HT1 Test Circuit Component Designations and Values

Part	Description	Part Number	Manufacturer
C1	220 pF Chip Capacitor	GRM1555C1H221JZ01	Murata
C2, C7	56 pF Chip Capacitors	GRM1555C1H560JZ01	Murata
C3, C4	Components Not Placed		
C5	180 pF Chip Capacitor	GRM1555C1H181JZ01	Murata
C6, C9, C10, C13	0.01 μ F Chip Capacitors	GRM155R71E103KA01	Murata
C8	1000 pF Chip Capacitor	GRM155R71E101KA01	Murata
C11, C12	100 pF Chip Capacitors	GRM1555C1H101JZ01	Murata
C14	68 pF Chip Capacitor	GRM1555C1H680JZ01	Murata
L1	6.8 nH Chip Inductor	0402CS-6N8XGL	Coilcraft
L2	23 nH Chip Inductor	0402CS-23NXGL	Coilcraft
L3	4.3 nH Chip Inductor	0402CS-4N3XGL	Coilcraft
R1	100 Ω Chip Resistor	RC0402JR-07-100RL	Yageo
R2	1100 Ω Chip Resistor	RC0402FR-07-1K1L	Yageo
R3	910 Ω Chip Resistor	RC0402FR-07-910RL	Yageo
R4	0 Ω , 1 A Chip Resistor	ERJ2GE0R00X	Panasonic
PCB	0.010", $\epsilon_r = 3.48$, Multilayer	RO4350B	Rogers

Note: Component numbers C3 and C4 are labeled on board but not placed.

50 OHM APPLICATION CIRCUIT: 1400 MHz

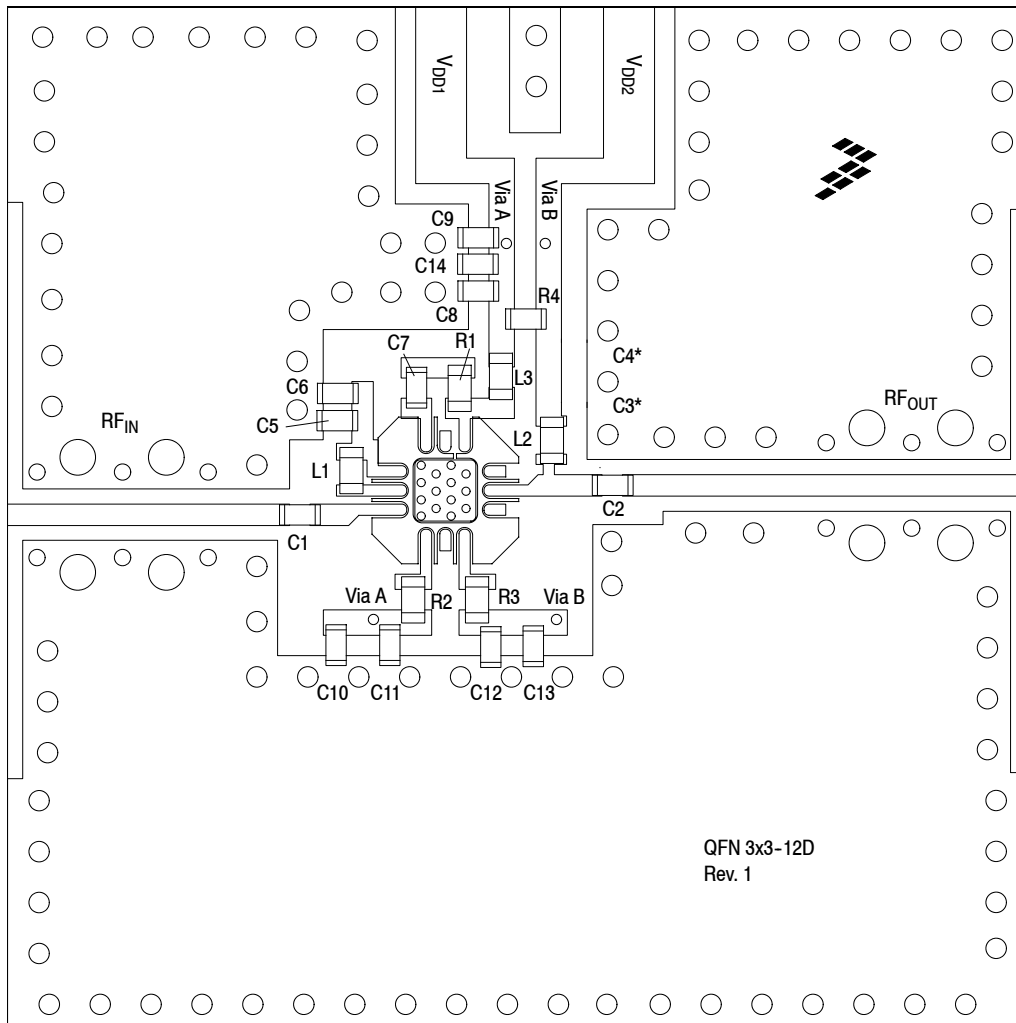

Note: Component numbers C3* and C4* are labeled on board but not placed.

Figure 22. MML09212HT1 Test Circuit Component Layout

Table 10. MML09212HT1 Test Circuit Component Designations and Values

Part	Description	Part Number	Manufacturer
C1	220 pF Chip Capacitor	GRM1555C1H221JZ01	Murata
C2, C7	56 pF Chip Capacitors	GRM1555C1H560JZ01	Murata
C3, C4	Components Not Placed		
C5	180 pF Chip Capacitor	GRM1555C1H181JZ01	Murata
C6, C9, C10, C13	0.01 μ F Chip Capacitors	GRM155R71E103KA01	Murata
C8	1000 pF Chip Capacitor	GRM155R71E101KA01	Murata
C11, C12	100 pF Chip Capacitors	GRM1555C1H101JZ01	Murata
C14	68 pF Chip Capacitor	GRM1555C1H680JZ01	Murata
L1	6.8 nH Chip Inductor	0402CS-6N8XGL	Coilcraft
L2	23 nH Chip Inductor	0402CS-23NXGL	Coilcraft
L3	4.3 nH Chip Inductor	0402CS-4N3XGL	Coilcraft
R1	100 Ω Chip Resistor	RC0402JR-07-100RL	Yageo
R2	1100 Ω Chip Resistor	RC0402FR-07-1K1L	Yageo
R3	910 Ω Chip Resistor	RC0402FR-07-910RL	Yageo
R4	0 Ω , 1 A Chip Resistor	ERJ2GE0R00X	Panasonic
PCB	0.010", $\epsilon_r = 3.48$, Multilayer	RO4350B	Rogers

(Test Circuit Component Designations and Values repeated for reference.)

MML09212HT1

50 OHM TYPICAL CHARACTERISTICS: 1400 MHz

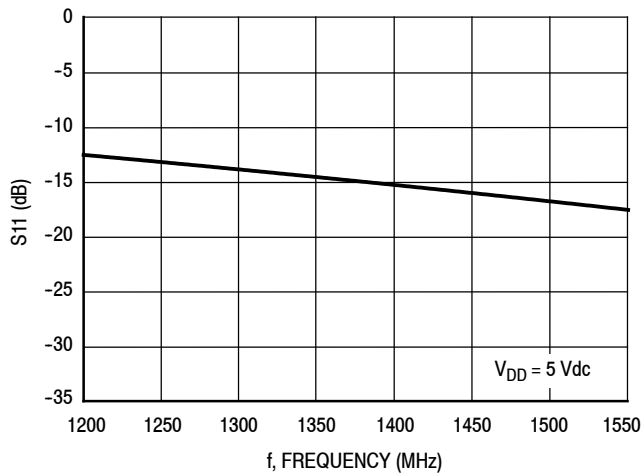

Figure 23. S11 versus Frequency

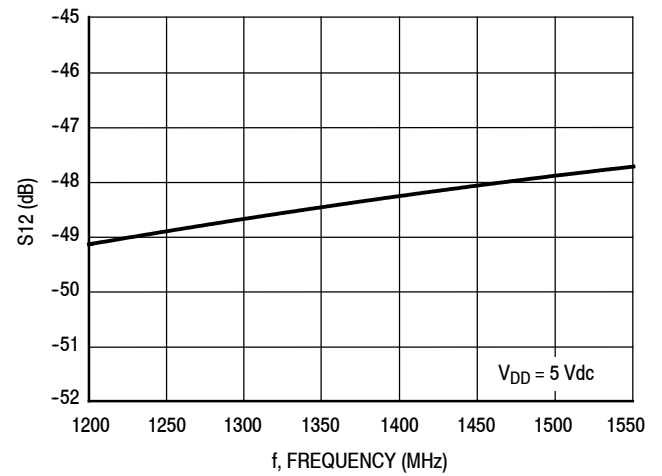

Figure 24. S12 versus Frequency

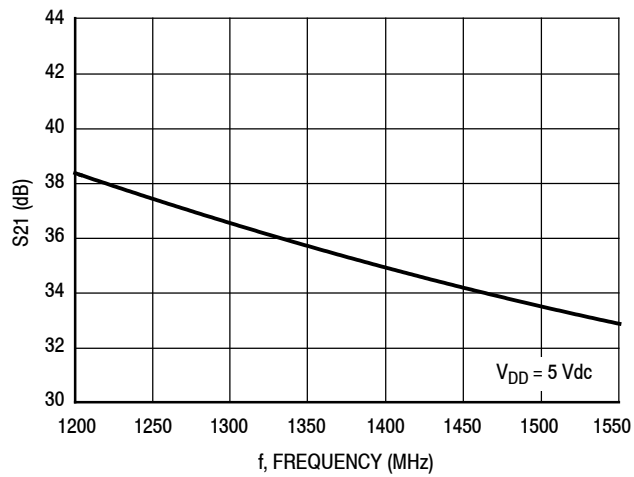

Figure 25. S21 versus Frequency

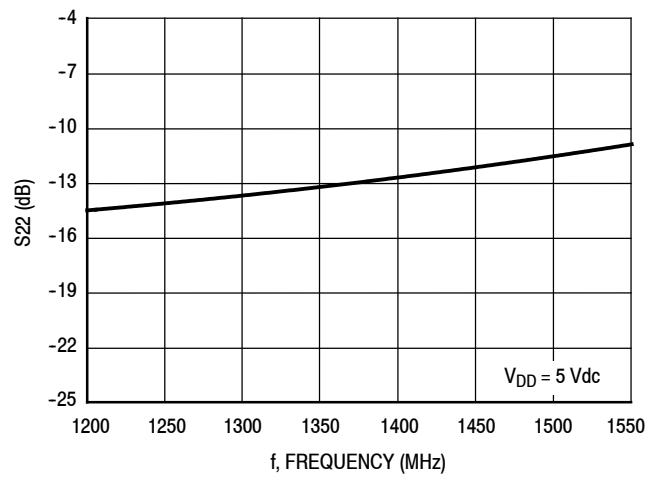

Figure 26. S22 versus Frequency

50 OHM TYPICAL CHARACTERISTICS: 1400 MHz

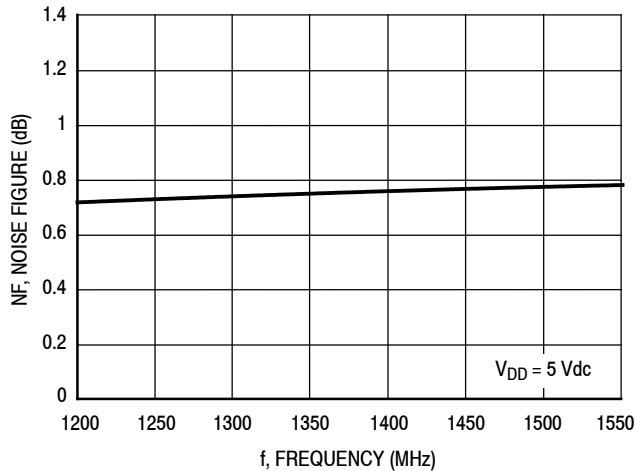

Figure 27. Noise Figure versus Frequency

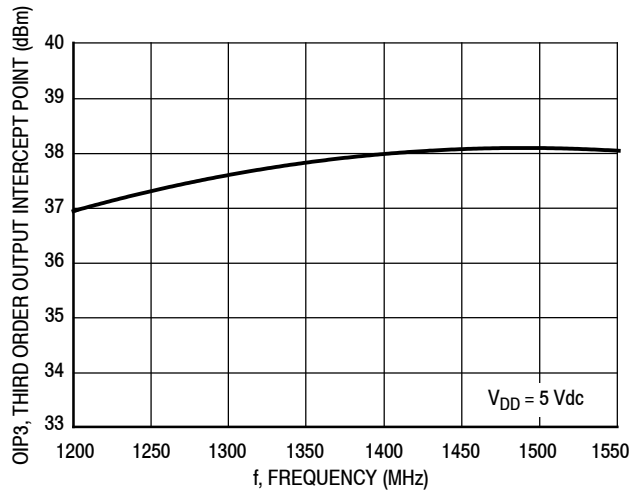

Figure 28. Third Order Output Intercept Point (Two-Tone) versus Frequency

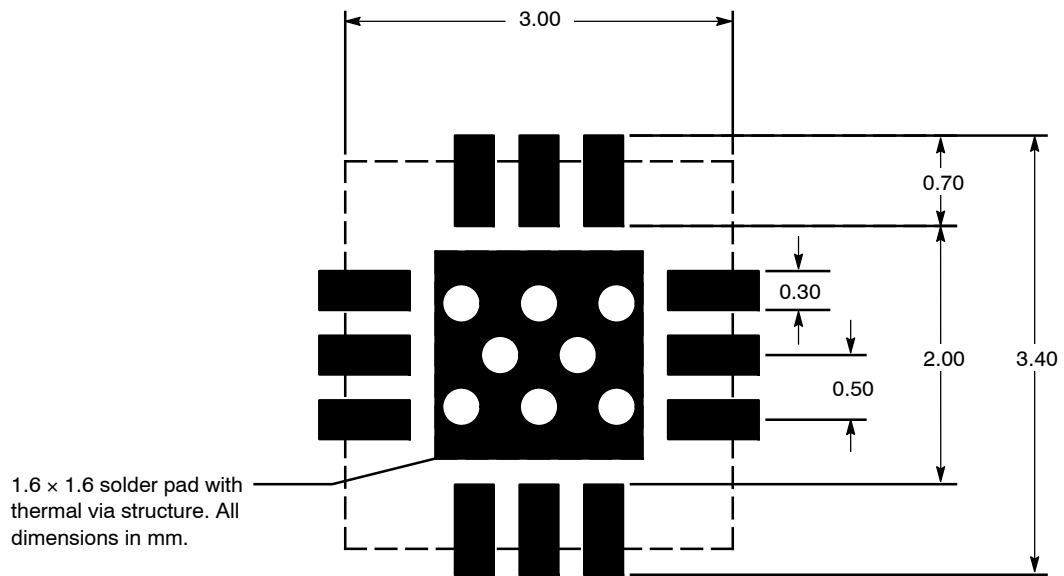
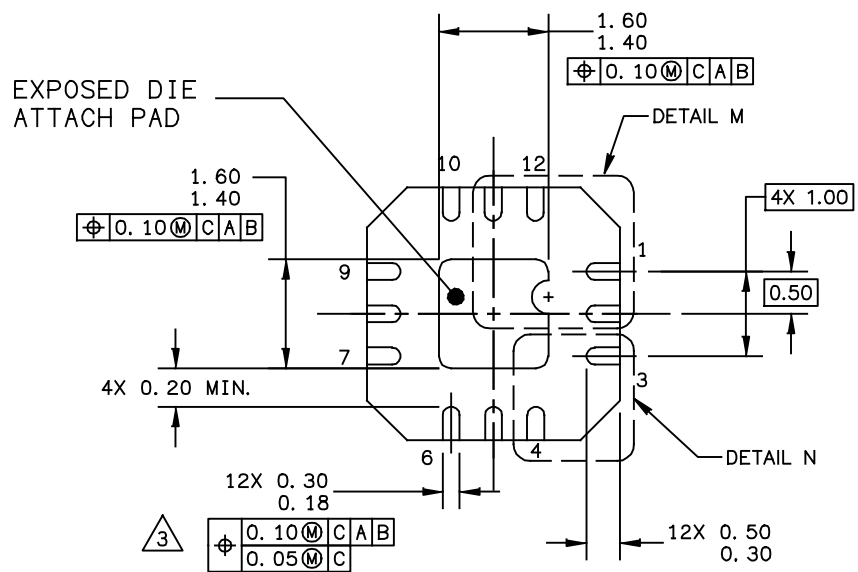
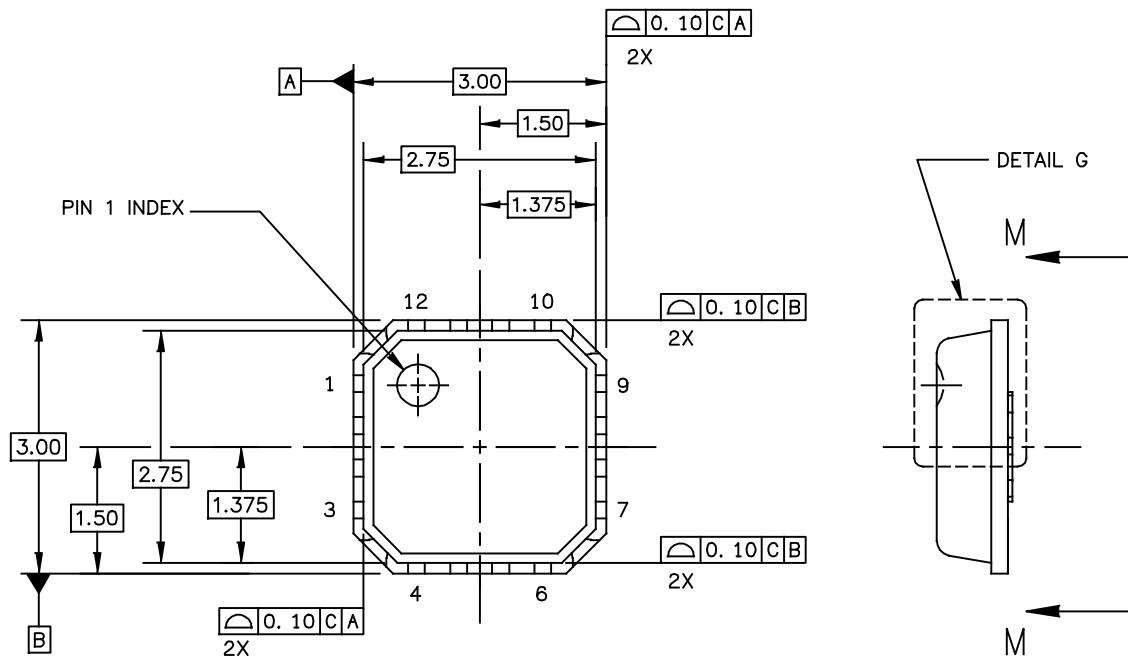

Figure 29. PCB Pad Layout for 12-Lead QFN 3 x 3



Figure 30. Product Marking

PACKAGE DIMENSIONS



VIEW M-M

© NXP SEMICONDUCTORS N. V. ALL RIGHTS RESERVED	MECHANICAL OUTLINE	PRINT VERSION NOT TO SCALE
TITLE: THERMALLY ENHANCED QUAD FLAT NON-LEADED PACKAGE (QFN) 12 TERMINAL, 0.5 PITCH (3X3X0.85)	DOCUMENT NO: 98ASA00227D	REV: A
	STANDARD: NON-JEDEC	
	SOT1677-1	30 NOV 2017

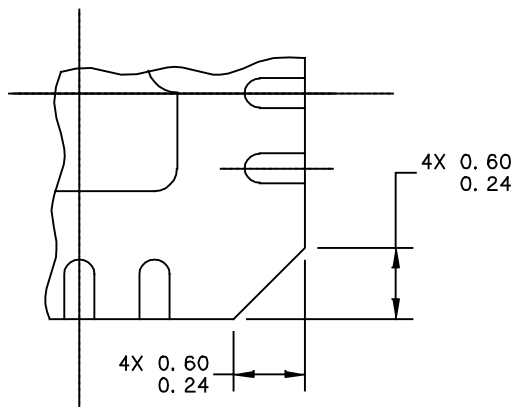

DETAIL N
CORNER CONFIGURATION

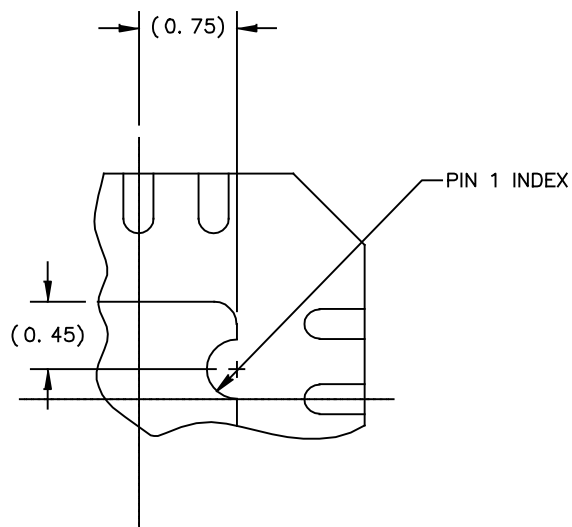

DETAIL M
PIN 1 BACKSIDE INDEX

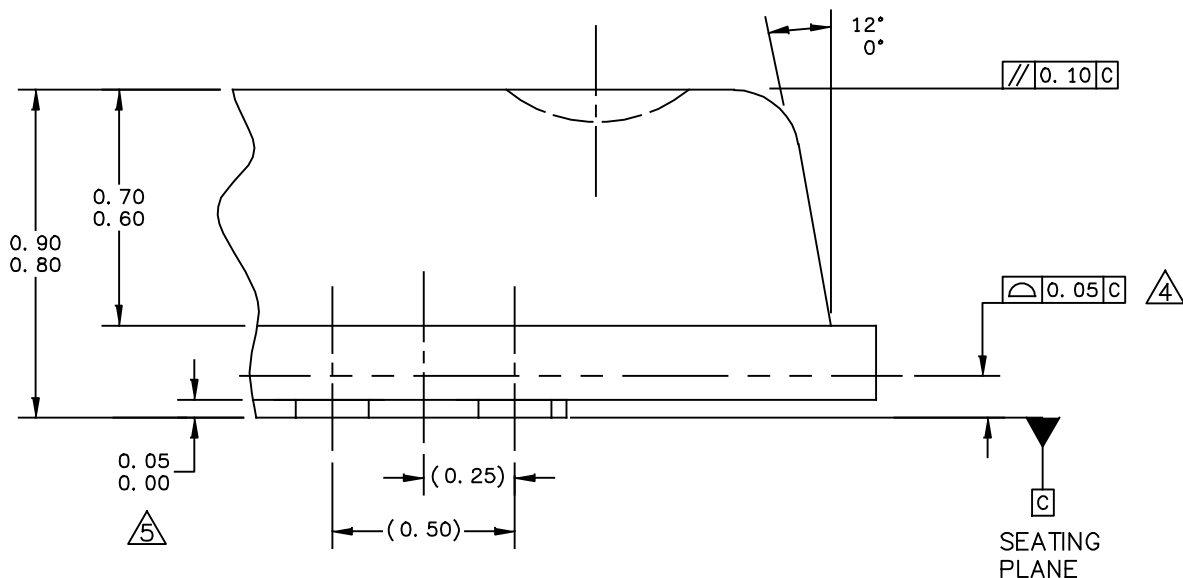

DETAIL G
VIEW ROTATED 90° CW

© NXP SEMICONDUCTORS N. V. ALL RIGHTS RESERVED	MECHANICAL OUTLINE	PRINT VERSION NOT TO SCALE
TITLE: THERMALLY ENHANCED QUAD FLAT NON-LEADED PACKAGE (QFN) 12 TERMINAL, 0.5 PITCH (3X3X0.85)	DOCUMENT NO: 98ASA00227D	REV: A
	STANDARD: NON-JEDEC	
	SOT1677-1	30 NOV 2017

NOTE:

1. ALL DIMENSIONS ARE IN MILLIMETERS.
2. DIMENSIONING & TOLERANCING PER ASME Y14.5 – 2009.
3. THIS DIMENSION APPLIES TO PLATED TERMINAL AND IS MEASURED BETWEEN 0.15 AND 0.30 MM FROM TERMINAL TIP.
4. BILATERAL COPLANARITY ZONE APPLIES TO THE EXPOSED PAD AS WELL AS THE TERMINALS.
5. THIS DIMENSION APPLIED ONLY FOR TERMINALS.

© NXP SEMICONDUCTORS N. V. ALL RIGHTS RESERVED	MECHANICAL OUTLINE	PRINT VERSION NOT TO SCALE
TITLE: THERMALLY ENHANCED QUAD FLAT NON-LEADED PACKAGE (QFN) 12 TERMINAL, 0.5 PITCH (3X3X0.85)	DOCUMENT NO: 98ASA00227D	REV: A
	STANDARD: NON-JEDEC	
	SOT1677-1	30 NOV 2017

APPENDIX: APPLICATION CIRCUITS WITH TWO-SUPPLY VOLTAGE

50 OHM APPLICATION CIRCUIT: 900 MHz

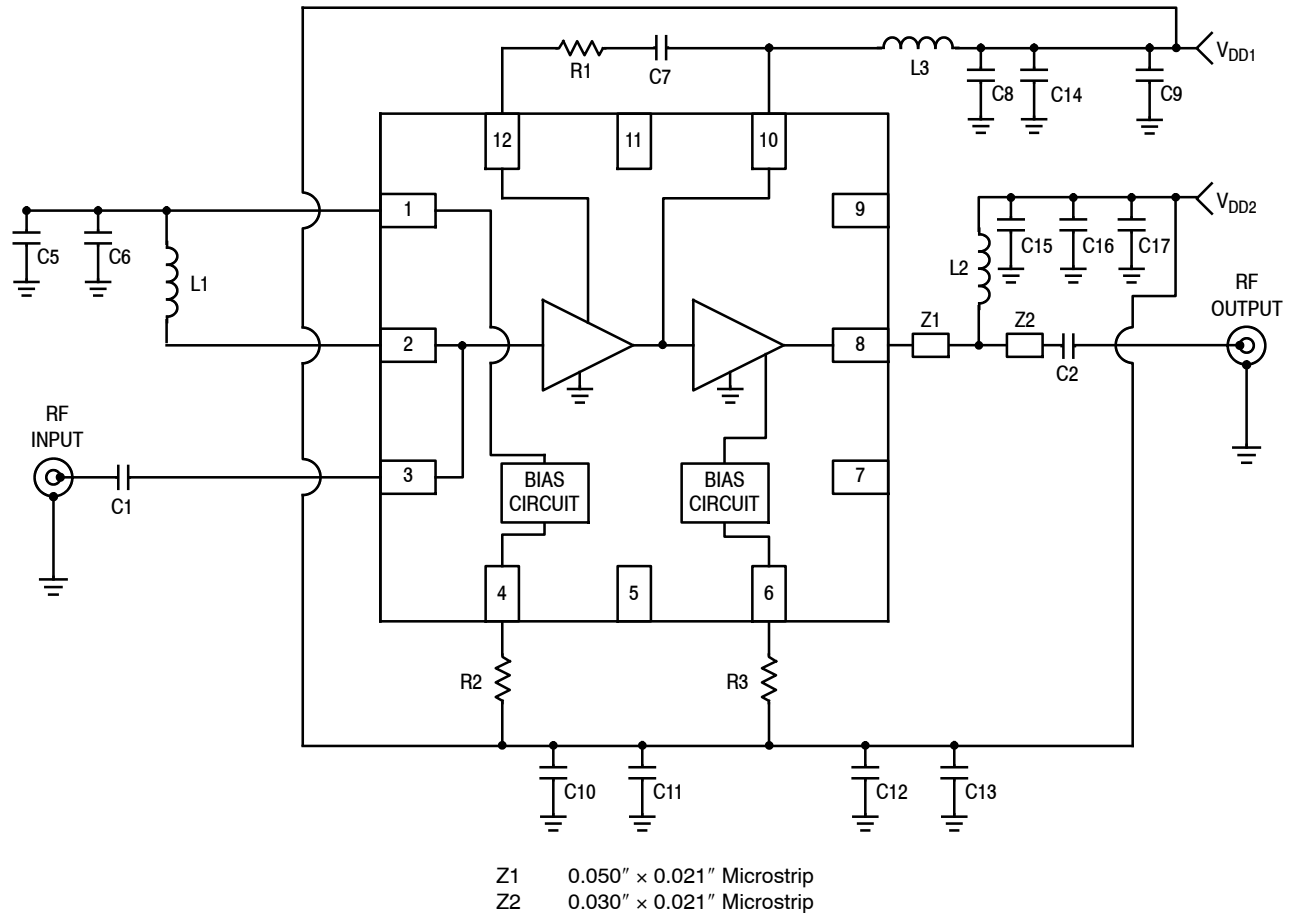

Figure A-1. MML09212HT1 Test Circuit Schematic

Table A-1. MML09212HT1 Test Circuit Component Designations and Values

Part	Description	Part Number	Manufacturer
C1, C2, C7, C14, C16	56 pF Chip Capacitors	GRM1555C1H560JZ01	Murata
C3, C4	Components Not Placed		
C5	180 pF Chip Capacitor	GRM1555C1H181JZ01	Murata
C6, C9, C10, C13, C17	0.01 μ F Chip Capacitors	GRM155R71E103KA01	Murata
C8, C15	1000 pF Chip Capacitors	GRM155R71E101KA01	Murata
C11, C12	100 pF Chip Capacitors	GRM1555C1H101JZ01	Murata
L1	12 nH Chip Inductor	0402CS-12NXGL	Coilcraft
L2	30 nH Chip Inductor	0402CS-30NXGL	Coilcraft
L3	8.2 nH Chip Inductor	0402CS-8N2XGL	Coilcraft
R1	82 Ω Chip Resistor	RC0402JR-07-82RL	Yageo
R2	1100 Ω Chip Resistor	RC0402FR-07-1K1L	Yageo
R3	910 Ω Chip Resistor	RC0402FR-07-910RL	Yageo
PCB	0.010", $\epsilon_r = 3.48$, Multilayer	RO4350B	Rogers

Note: Component numbers C3 and C4 are labeled on board but not placed.

50 OHM APPLICATION CIRCUIT: 900 MHz

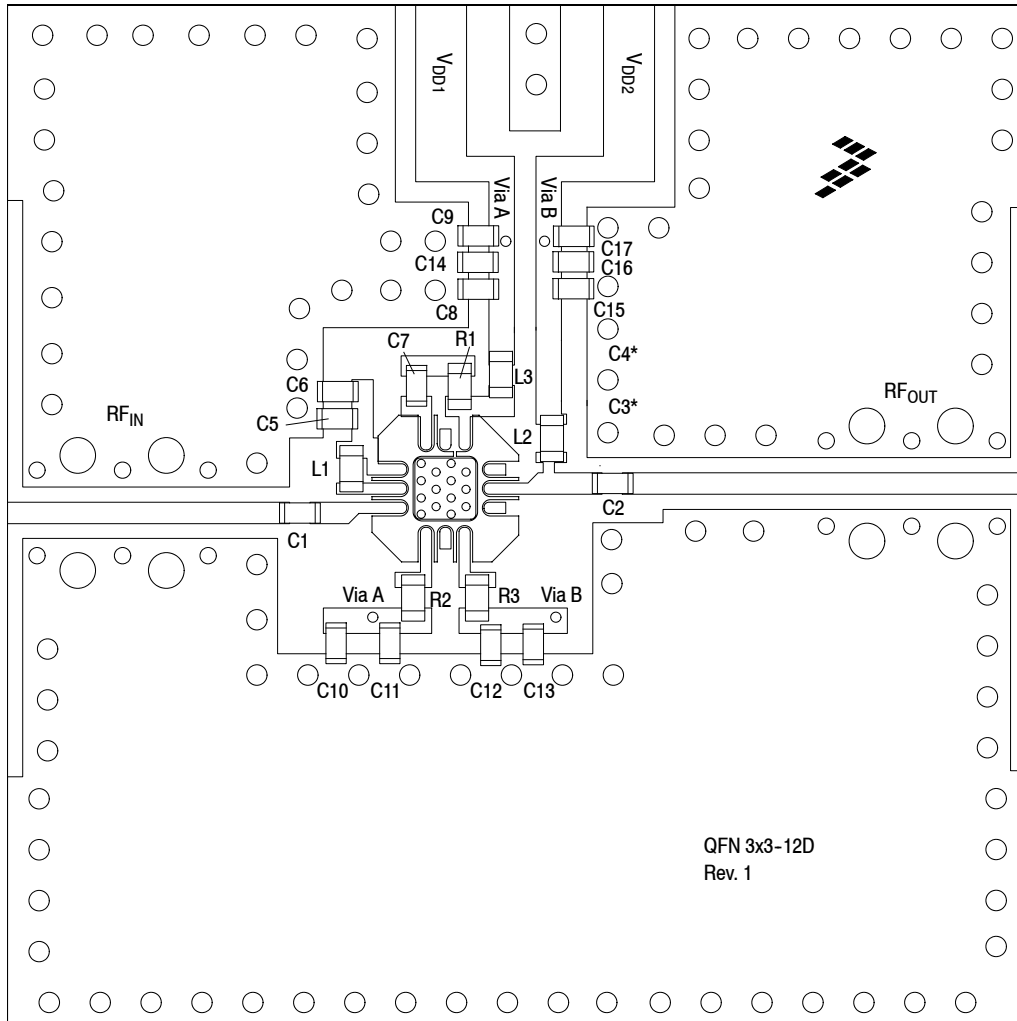

Note: Component numbers C3* and C4* are labeled on board but not placed.

Figure A-2. MML09212HT1 Test Circuit Component Layout

Table A-1. MML09212HT1 Test Circuit Component Designations and Values

Part	Description	Part Number	Manufacturer
C1, C2, C7, C14, C16	56 pF Chip Capacitors	GRM1555C1H560JZ01	Murata
C3, C4	Components Not Placed		
C5	180 pF Chip Capacitor	GRM1555C1H181JZ01	Murata
C6, C9, C10, C13, C17	0.01 μ F Chip Capacitors	GRM155R71E103KA01	Murata
C8, C15	1000 pF Chip Capacitors	GRM155R71E101KA01	Murata
C11, C12	100 pF Chip Capacitors	GRM1555C1H101JZ01	Murata
L1	12 nH Chip Inductor	0402CS-12NXGL	Coilcraft
L2	30 nH Chip Inductor	0402CS-30NXGL	Coilcraft
L3	8.2 nH Chip Inductor	0402CS-8N2XGL	Coilcraft
R1	82 Ω Chip Resistor	RC0402JR-07-82RL	Yageo
R2	1100 Ω Chip Resistor	RC0402FR-07-1K1L	Yageo
R3	910 Ω Chip Resistor	RC0402FR-07-910RL	Yageo
PCB	0.010", $\epsilon_r = 3.48$, Multilayer	RO4350B	Rogers

(Test Circuit Component Designations and Values repeated for reference.)

50 OHM APPLICATION CIRCUIT: 400 MHz

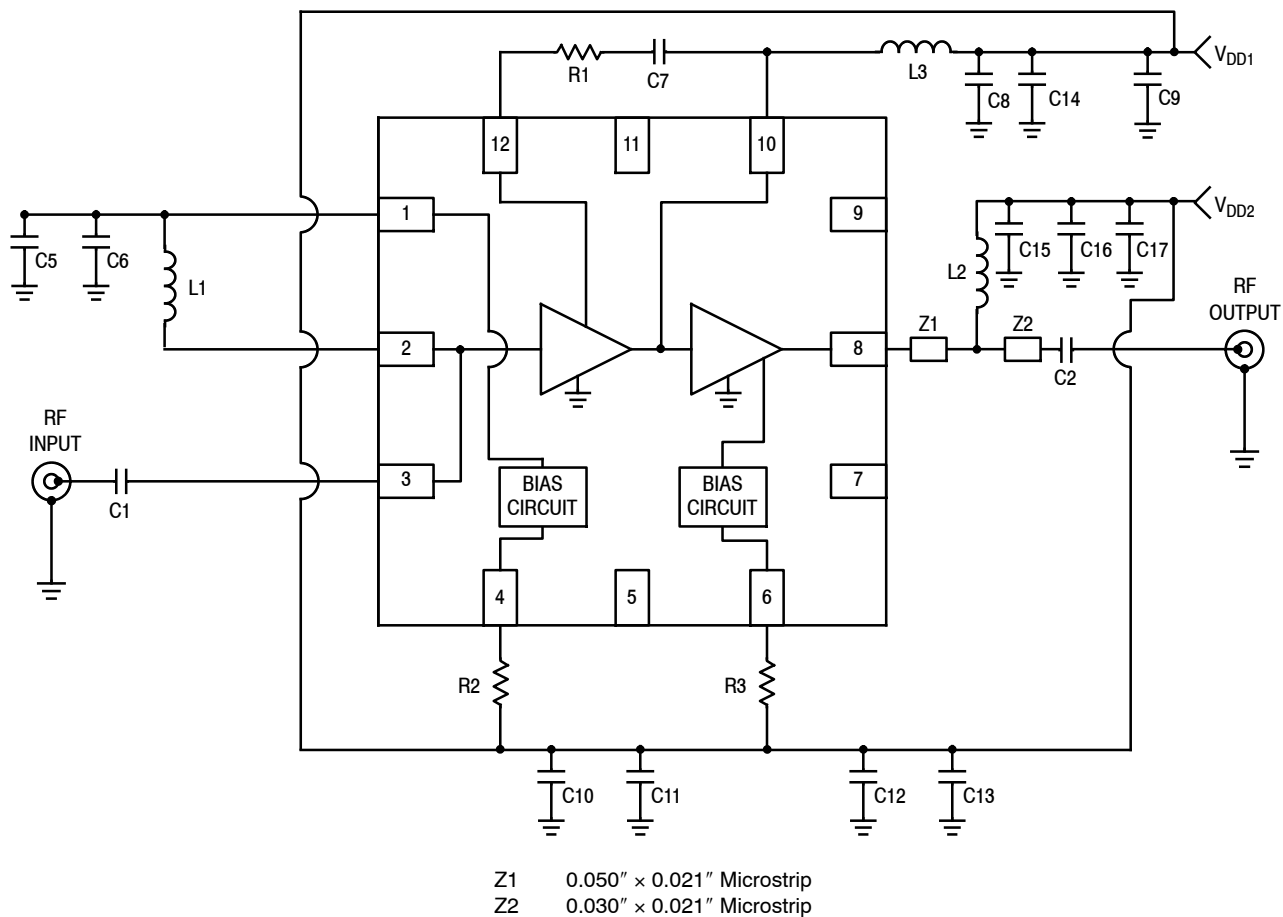

Figure A-3. MML09212HT1 Test Circuit Component Layout

Table A-2. MML09212HT1 Test Circuit Component Designations and Values

Part	Description	Part Number	Manufacturer
C1, C2	100 pF Chip Capacitors	GRM1555C1H101JZ01	Murata
C3, C4	Components Not Placed		
C5, C7, C8, C11, C12, C15	390 pF Chip Capacitors	GRM1555C1H391JZ01	Murata
C6, C9, C10, C13, C16	0.01 μ F Chip Capacitors	GRM155R71E103KA01	Murata
C14, C17	1000 pF Chip Capacitors	GRM155R71E101KA01	Murata
L1	20 nH Chip Inductor	0402CS-20NXGL	Coilcraft
L2, L5	30 nH Chip Inductors	0402CS-30NXGL	Coilcraft
L3	16 nH Chip Inductor	0402CS-16NNXGL	Coilcraft
L4	1.2 nH Chip Inductor	0402CS-1N2XJL	Coilcraft
R1	100 Ω Chip Resistor	RC0402JR-07-100RL	Yageo
R2	1100 Ω Chip Resistor	RC0402FR-07-1K1L	Yageo
R3	910 Ω Chip Resistor	RC0402FR-07-910RL	Yageo
PCB	0.010", $\epsilon_r = 3.48$, Multilayer	RO4350B	Rogers

Note: Component numbers C3 and C4 are labeled on board but not placed.

50 OHM APPLICATION CIRCUIT: 400 MHz

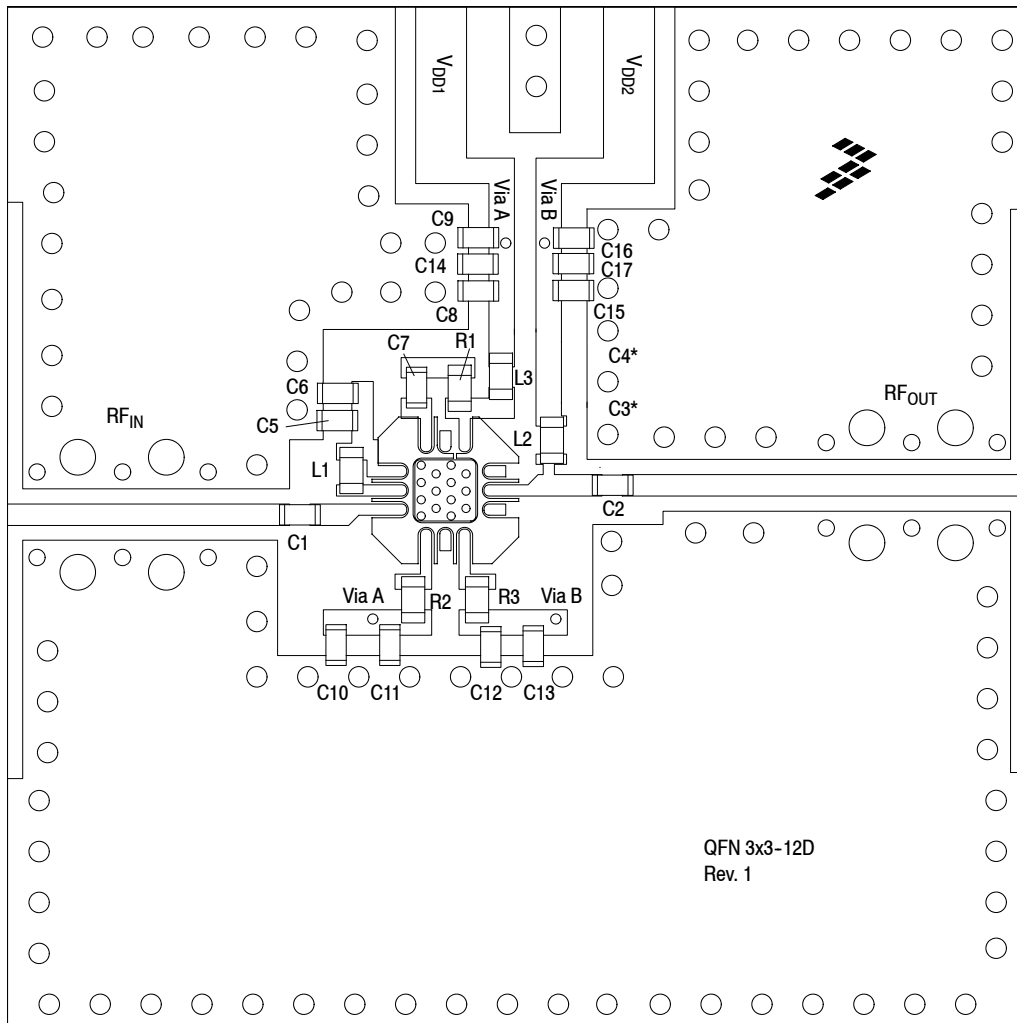

Note: Component numbers C3* and C4* are labeled on board but not placed.

Figure A-4. MML09212HT1 Test Circuit Component Layout

Table A-2. MML09212HT1 Test Circuit Component Designations and Values

Part	Description	Part Number	Manufacturer
C1, C2	100 pF Chip Capacitors	GRM1555C1H101JZ01	Murata
C3, C4	Components Not Placed		
C5, C7, C8, C11, C12, C15	390 pF Chip Capacitors	GRM1555C1H391JZ01	Murata
C6, C9, C10, C13, C16	0.01 μ F Chip Capacitors	GRM155R71E103KA01	Murata
C14, C17	1000 pF Chip Capacitors	GRM155R71E101KA01	Murata
L1	20 nH Chip Inductor	0402CS-20NXGL	Coilcraft
L2, L5	30 nH Chip Inductors	0402CS-30NXGL	Coilcraft
L3	16 nH Chip Inductor	0402CS-16NNXGL	Coilcraft
L4	1.2 nH Chip Inductor	0402CS-1N2XJL	Coilcraft
R1	100 Ω Chip Resistor	RC0402JR-07-100RL	Yageo
R2	1100 Ω Chip Resistor	RC0402FR-07-1K1L	Yageo
R3	910 Ω Chip Resistor	RC0402FR-07-910RL	Yageo
PCB	0.010", $\epsilon_r = 3.48$, Multilayer	RO4350B	Rogers

(Test Circuit Component Designations and Values repeated for reference.)

50 OHM APPLICATION CIRCUIT: 1400 MHz

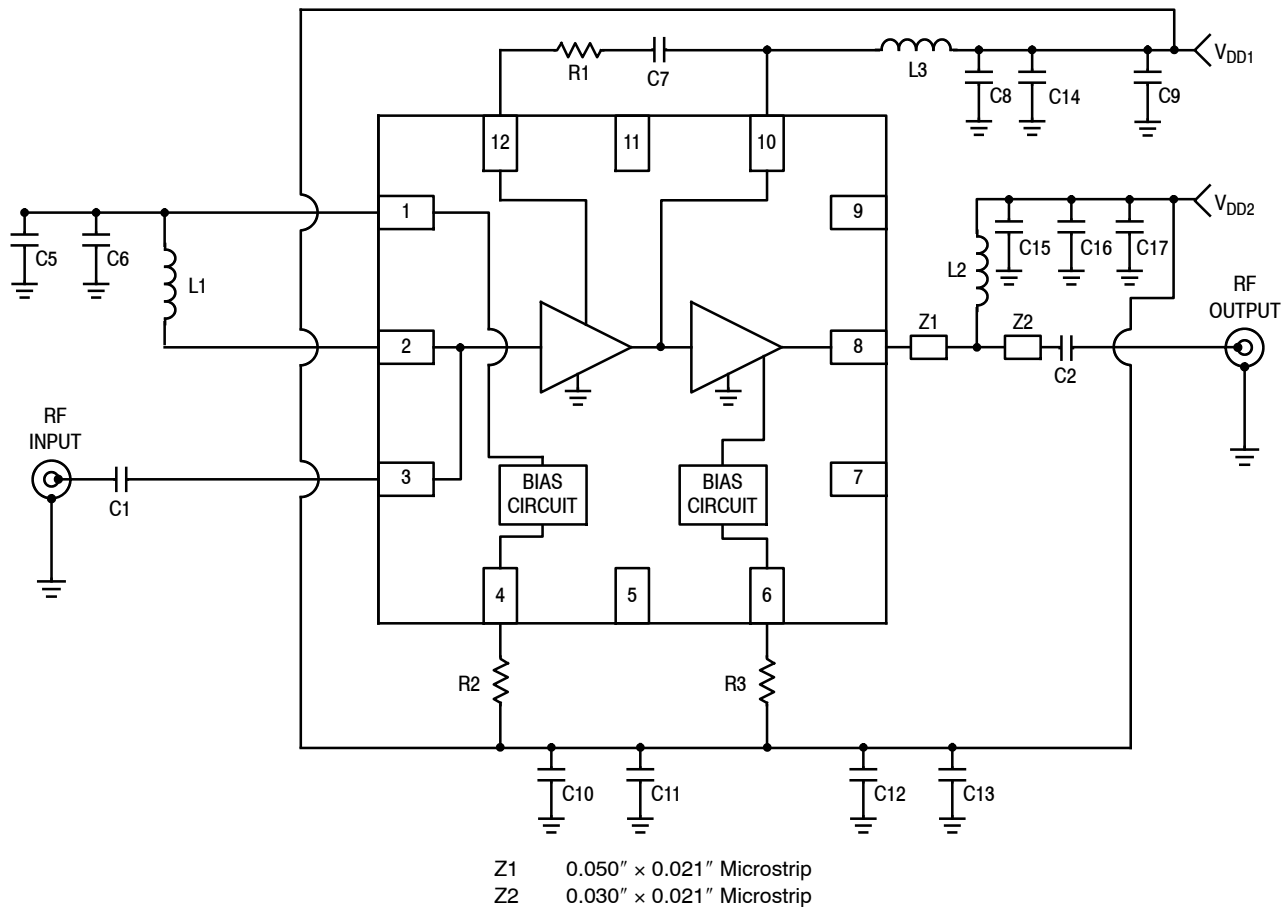

Figure A-5. MML09212HT1 Test Circuit Component Layout

Table A-3. MML09212HT1 Test Circuit Component Designations and Values

Part	Description	Part Number	Manufacturer
C1	220 pF Chip Capacitor	GRM1555C1H221JZ01	Murata
C2, C7	56 pF Chip Capacitors	GRM1555C1H560JZ01	Murata
C3, C4	Components Not Placed		
C5	180 pF Chip Capacitor	GRM1555C1H181JZ01	Murata
C6, C9, C10, C13, C17	0.01 μF Chip Capacitors	GRM155R71E103KA01	Murata
C8, C15	1000 pF Chip Capacitors	GRM155R71E101KA01	Murata
C11, C12	100 pF Chip Capacitors	GRM1555C1H101JZ01	Murata
C14, C16	68 pF Chip Capacitors	GRM1555C1H680JZ01	Murata
L1	6.8 nH Chip Inductor	0402CS-6N8XGL	Coilcraft
L2	23 nH Chip Inductor	0402CS-23NXGL	Coilcraft
L3	4.3 nH Chip Inductor	0402CS-4N3XGL	Coilcraft
R1	100 Ω Chip Resistor	RC0402JR-07-100RL	Yageo
R2	1100 Ω Chip Resistor	RC0402FR-07-1K1L	Yageo
R3	910 Ω Chip Resistor	RC0402FR-07-910RL	Yageo
PCB	0.010", ε _r = 3.48, Multilayer	RO4350B	Rogers

Note: Component numbers C3 and C4 are labeled on board but not placed.

50 OHM APPLICATION CIRCUIT: 1400 MHz

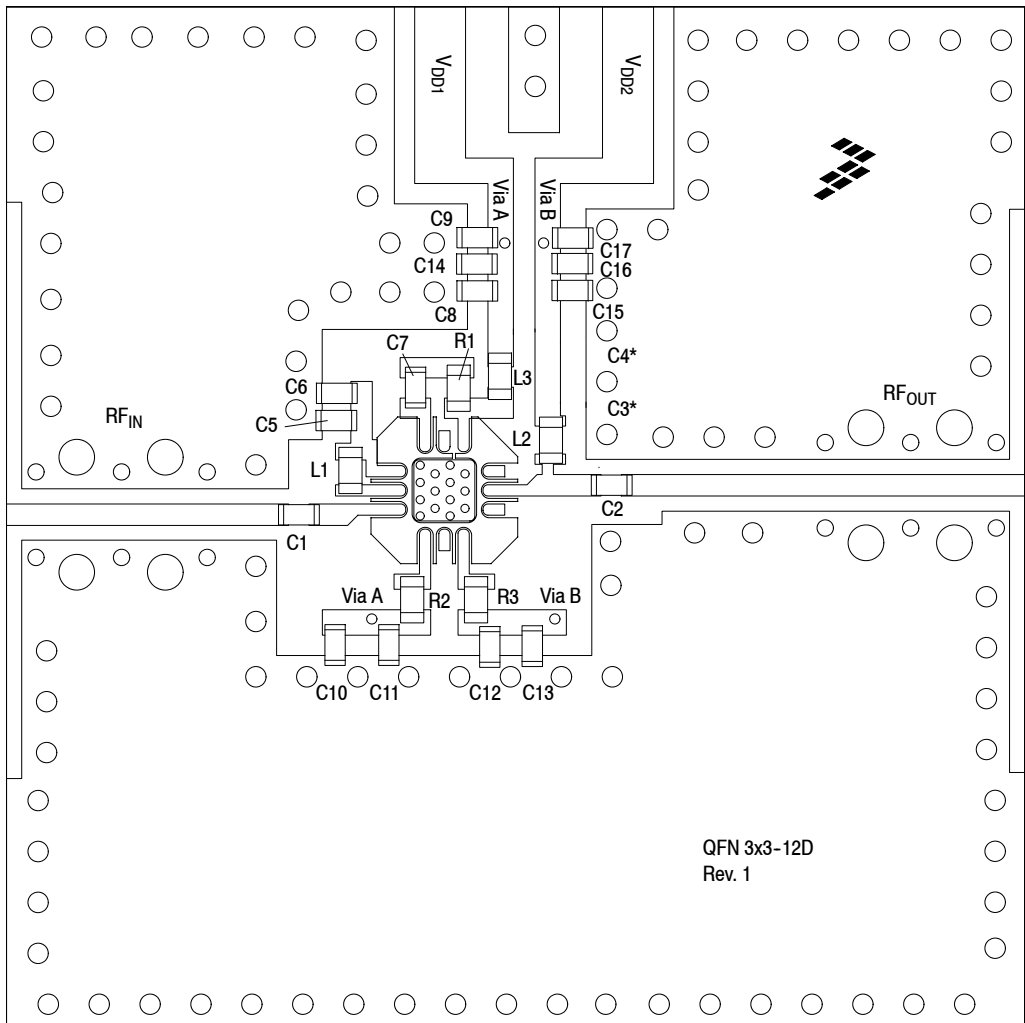

Note: Component numbers C3* and C4* are labeled on board but not placed.

Figure A-6. MML09212HT1 Test Circuit Component Layout

Table A-3. MML09212HT1 Test Circuit Component Designations and Values

Part	Description	Part Number	Manufacturer
C1	220 pF Chip Capacitor	GRM1555C1H221JZ01	Murata
C2, C7	56 pF Chip Capacitors	GRM1555C1H560JZ01	Murata
C3, C4	Components Not Placed		
C5	180 pF Chip Capacitor	GRM1555C1H181JZ01	Murata
C6, C9, C10, C13, C17	0.01 μ F Chip Capacitors	GRM155R71E103KA01	Murata
C8, C15	1000 pF Chip Capacitors	GRM155R71E101KA01	Murata
C11, C12	100 pF Chip Capacitors	GRM1555C1H101JZ01	Murata
C14, C16	68 pF Chip Capacitors	GRM1555C1H680JZ01	Murata
L1	6.8 nH Chip Inductor	0402CS-6N8XGL	Coilcraft
L2	23 nH Chip Inductor	0402CS-23NXGL	Coilcraft
L3	4.3 nH Chip Inductor	0402CS-4N3XGL	Coilcraft
R1	100 Ω Chip Resistor	RC0402JR-07-100RL	Yageo
R2	1100 Ω Chip Resistor	RC0402FR-07-1K1L	Yageo
R3	910 Ω Chip Resistor	RC0402FR-07-910RL	Yageo
PCB	0.010", $\epsilon_r = 3.48$, Multilayer	RO4350B	Rogers

(Test Circuit Component Designations and Values repeated for reference.)

MML09212HT1

PRODUCT DOCUMENTATION, SOFTWARE AND TOOLS

Refer to the following resources to aid your design process.

Application Notes

- AN1955: Thermal Measurement Methodology of RF Power Amplifiers
- AN3100: General Purpose Amplifier and MMIC Biasing

Software

- .s2p File

Development Tools

- Printed Circuit Boards

To Download Resources Specific to a Given Part Number:

1. Go to <http://www.nxp.com/RF>
2. Search by part number
3. Click part number link
4. Choose the desired resource from the drop down menu

FAILURE ANALYSIS

At this time, because of the physical characteristics of the part, failure analysis is limited to electrical signature analysis. In cases where NXP is contractually obligated to perform failure analysis (FA) services, full FA may be performed by third party vendors with moderate success. For updates contact your local NXP Sales Office.

REVISION HISTORY

The following table summarizes revisions to this document.

Revision	Date	Description
0	Oct. 2012	<ul style="list-style-type: none">• Initial Release of Data Sheet
1	Apr. 2013	<ul style="list-style-type: none">• Table 1, Typical Performance: changed 400 MHz Application Circuit Third Order Output Intercept Point value from 38 dBm to 37 dBm to reflect the true capability of the device, p. 1• Added 900 MHz, 50 Ohm Operation, application circuit figures as follows:<ul style="list-style-type: none">- Figure 5, S11 versus Frequency versus Temperature, p. 5- Figure 6, S12 versus Frequency versus Temperature, p. 5- Figure 7, S21 versus Frequency versus Temperature, p. 5- Figure 8, S22 versus Frequency versus Temperature, p. 5- Figure 9, Noise Figure versus Frequency versus Temperature, p. 6- Figure 10, Power Gain versus Output Power versus Temperature, CW, p. 6- Figure 11, Third Order Output Intercept Point (Two-Tone) versus Frequency versus Temperature, p. 6- Figure 12, P1dB versus Frequency versus Temperature, CW, p. 6• Added 400 MHz, 50 Ohm Operation, application circuit figures as follows:<ul style="list-style-type: none">- Figure 15, S11 versus Frequency, p. 9- Figure 16, S12 versus Frequency, p. 9- Figure 17, S21 versus Frequency, p. 9- Figure 18, S22 versus Frequency, p. 9- Figure 19, Noise Figure versus Frequency, p. 10- Figure 20, Third Order Output Intercept Point (Two-Tone) versus Frequency, p. 10• Added 1400 MHz, 50 Ohm Operation, application circuit figures as follows:<ul style="list-style-type: none">- Figure 23, S11 versus Frequency, p. 13- Figure 24, S12 versus Frequency, p. 13- Figure 25, S21 versus Frequency, p. 13- Figure 26, S22 versus Frequency, p. 13- Figure 27, Noise Figure versus Frequency, p. 14- Figure 28, Third Order Output Intercept Point (Two-Tone) versus Frequency, p. 14• Added Appendix: Application Circuits with Two-Supply Voltage, pp. 19–24

(continued)

MML09212HT1

REVISION HISTORY (cont.)

Revision	Date	Description
2	Sept. 2014	<ul style="list-style-type: none">• Table 2, Maximum Ratings: updated Junction Temperature from 150°C to 175°C to reflect recent test results of the device, p. 1• Added Failure Analysis information, p. 25
3	Jan. 2018	<ul style="list-style-type: none">• Fig. 30, Product Marking: updated product marking to reflect correct marking: ML01. Updated date code line to reflect improved traceability information, p. 15.

How to Reach Us:

Home Page:
nxp.com

Web Support:
nxp.com/support

Information in this document is provided solely to enable system and software implementers to use NXP products. There are no express or implied copyright licenses granted hereunder to design or fabricate any integrated circuits based on the information in this document. NXP reserves the right to make changes without further notice to any products herein.

NXP makes no warranty, representation, or guarantee regarding the suitability of its products for any particular purpose, nor does NXP assume any liability arising out of the application or use of any product or circuit, and specifically disclaims any and all liability, including without limitation consequential or incidental damages. "Typical" parameters that may be provided in NXP data sheets and/or specifications can and do vary in different applications, and actual performance may vary over time. All operating parameters, including "typicals," must be validated for each customer application by customer's technical experts. NXP does not convey any license under its patent rights nor the rights of others. NXP sells products pursuant to standard terms and conditions of sale, which can be found at the following address: nxp.com/SalesTermsandConditions.

NXP, the NXP logo, Freescale and the Freescale logo are trademarks of NXP B.V. All other product or service names are the property of their respective owners.
© 2012–2014, 2018 NXP B.V.



Mouser Electronics

Authorized Distributor

Click to View Pricing, Inventory, Delivery & Lifecycle Information:

[NXP:](#)

[MML09212HT1](#)