

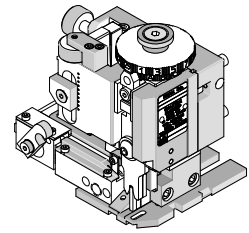

**Mini-Mac  
Applicator**

**Application Tooling  
Specification Sheet**



**Order No. 63892-4300**

**FEATURES**

- Directly adapts to most automatic wire processing machines
- Applicator designed to industry standard mounting and shut height 135.80mm (5.346")
- Quick set-up time; plus the crimp height, track and feed adjustments can be set without removing the applicator from the press
- Fine adjustment allows users to achieve target with little effort by adjusting in increments of .015mm (.0006") for conductor crimp height and .063mm (.0025") for insulation height
- Independent adjustment rings allow users to quickly adjust the conductor or insulation crimp height without affecting each other.

**SCOPE**

Products: 2.36mm (.093") Diameter, Standard .093" Pin and Socket Crimp Grounding Terminal, 16-24 AWG

Terminal Series No.	Terminal Order No.	Wire Size		Insulation Diameter		Strip Length	
		AWG	mm <sup>2</sup>	mm	In.	mm	In.
1973	02-09-8103	16-24	1.30-0.20	3.04 Max.	.120 Max.	3.96-5.54	.156-.218
1973-1	02-09-8107						

**DEFINITION OF TERMS**

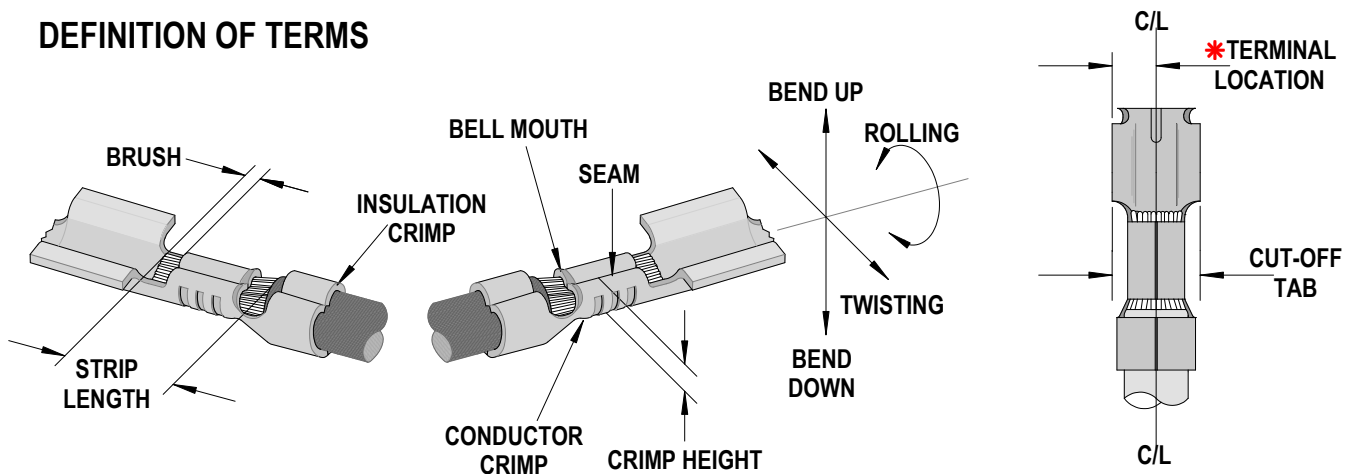

\*Terminal is to be centrally located between the two (2) cut-off tab edges by one half of the total cut-off tab tolerance.

This illustration is a generic terminal representation and not an exact image of any terminal listed in the scope.

### CRIMP SPECIFICATIONS

Terminal Series No.	Bell mouth		*Cut-off Tab		Conductor Brush	
	mm	In.	mm	In.	mm	In.
1973			3.53-3.69	.139-.145		
1973-1						

Terminal Series No.	Bend up	Bend down	Twist	Roll	Punch Width (Ref)				Seam Seam shall not be open and no wire allowed out of the crimping area
					Conductor		Insulation		
	Degree		Degree		mm	In.	mm	In.	
1973					1.925	.0757	3.10	.122	
1973-1									

**NOTE:** Some of the specifications in these charts above are intentionally left blank due to the fact that the information does not currently exist.

After crimping, the conductor profile should measure the following.

Terminal Series No.	Wire Size		Conductor				Pull Force Minimum	
			Crimp Height		Crimp Width (REF)			
	AWG	mm <sup>2</sup>	mm	In.	mm	In.	N	Lb.
1973, 1973-1	16	1.30	1.42-1.47	.056-.058			155.8	35.00
	18	0.80	1.37-1.42	.054-.056			133.5	30.00
	20	0.50	1.32-1.37	.052-.054			80.1	18.00
	22	0.35	1.29-1.35	.051-.053			62.3	14.00
	24	0.20	1.24-1.29	.049-.051			40.1	9.00

Tool Qualification Notes:

1. Pull Force should be measured with no influence from the insulation crimp.
2. The above specifications are guidelines to an optimum crimp.

**PARTS LIST**

<b>Mini-Mac Applicator 63892-4300</b>				
<b>Item</b>	<b>Order No</b>	<b>Engineering No.</b>	<b>Description</b>	<b>Quantity</b>
<b>Perishable Tooling</b>				
	63892-4370	63892-4370	Tool Kit (All "Y" Items)	REF
1	11-18-4050	60706-12	Conductor Punch	1 Y
2	11-18-4049	60706-11	Combination Anvil	1 Y
3	11-18-4046	60706-8	Insulation Punch	1 Y
4	11-18-4447	60706-31	Cut-Off Punch	1 Y
5	11-18-4044	60706-6	Cut-off Die Plate	1 Y
<b>Other Components</b>				
6	11-17-0094	1739-37	Compression Spring	1
7	11-17-1172	4151-20	Terminal Drag Plate	1
8	11-18-4040	60706-2	Cover Plate	1
9	11-18-4042	60706-4	Terminal Guide	1
10	11-18-4043	60706-5	Insulation Punch Holder	1
11	11-18-4422	60706-28	Hold Down Plunger	1
12	11-18-4423	60706-29	Stripper and Wire Stop	1
13	11-18-4446	60706-30	Stripper and Wire Stop Holder	1
14	11-18-4562	60700-15	Slug Ramp	1
15	63803-5105	63803-5105	Conductor Bushing	1
<b>Frame</b>				
16	63801-3201	63801-3201	Top	1
17	63801-3282	63801-3282	Base	1
18	63801-6550	63801-6550	Track	1
<b>Hardware</b>				
19	N/A	N/A	M3 by 8 Long SHCS	4**
20	N/A	N/A	M4 by 12 Long BHCS	2**
21	N/A	N/A	M4 by 16 Long SHCS	2**
22	N/A	N/A	M8 by 20 Long BHCS	1**
23	N/A	N/A	#6-32 by 3/8" Long BHCS	3**
24	N/A	N/A	#8-32 by 1/4" Long BHCS	1**
25	N/A	N/A	#1/4-20 by 1/2" Long SHCS	2**
26	N/A	N/A	1/8 Diameter by 3/8" Long Roll Pin	2**
** Available from an industrial supply company such as MSC (1-800-645-7270).				

### Assembly Drawing

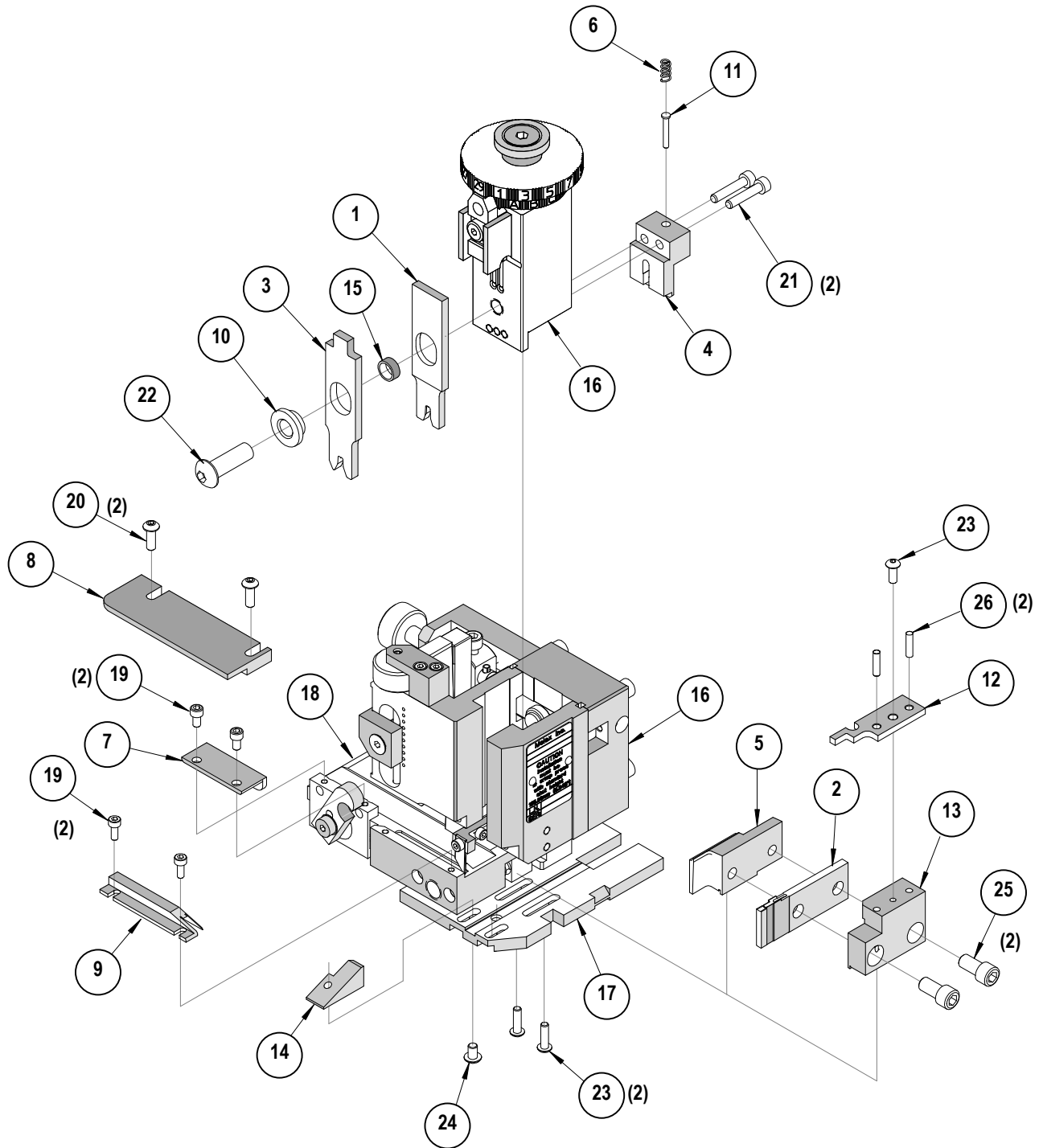

Figure 1

## NOTES

1. Molex recommends an extra perishable tooling kit be maintained at your facility.
2. Verify tooling alignment by manually cycling the press and applicator before crimping under power. Check that all screws are tight.
3. Slugs, terminals, dirt, and oil should be kept clear of work area.
4. Wear safety glasses at all times.
5. For recommended maintenance refer to the Mini-Mac Manual.

**CAUTION:** This applicator should only be used in a press with a shut height of 135.80 mm (5.346"). Tooling damage could result at a lower setting

**CAUTION:** To prevent injury, never operate this applicator without the guards supplied with the press or wire-processing machine in place. Reference the press or wire processing manufacturer's instruction manual.

**CAUTION:** Molex crimp specifications are valid only when used with Molex terminals, applicators and tooling.

## Contact Information

For more information on Molex application tooling please contact Molex at 1-800-786-6539.

Visit our Web site at <http://www.molex.com>

# Mouser Electronics

Authorized Distributor

Click to View Pricing, Inventory, Delivery & Lifecycle Information:

[Molex:](#)

[63892-4370](#)