

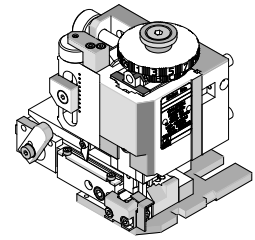

**FineAdjust
Applicator**

**Application Tooling
Specification Sheet**



Order No. 63900-4400

FEATURES

- Quick punch removal with the push of a button for fast and easy tooling change
- Applicator designed to industry standard mounting and shut height 135.80mm (5.346")
- Quick set-up time; plus the crimp height, track and feed adjustments can be set without removing the applicator from the press
- Fine adjustment allows users to achieve target with little effort by adjusting in increments of .015mm (.0006") for conductor crimp height and .063mm (.0025") for insulation height
- Independent adjustment rings allow users to quickly adjust the conductor or insulation crimp height without affecting each other
- Directly adapts to most automatic wire processing machines

SCOPE

Products: Micro-Fit 3.0™ Crimp Terminal, Male and Female, 26-30 AWG.

Terminal Series No	Terminal Order No.			Wire Size		✘ Insulation Diameter		Strip Length	
				AWG	mm ²	mm	In.	mm	In.
43030	43030-0004	43030-0006		26-30	0.12-0.05	1.12-1.27	.044-.050	2.54-2.92	.100-.115
	43030-0005	43030-0056							
43031	43031-0004	43031-0006	43031-0106	26-30	0.12-0.05	1.12-1.27	.044-.050	2.54-2.92	.100-.115
	43031-0005	43031-0019							
45773	45773-0004	45773-0005	45773-0006	26-30	0.12-0.05	1.12-1.27	.044-.050	2.54-2.92	.100-.115

✘ This Applicator will crimp large wire insulation diameter shown above.
Applicator 63900-1600 should be used for insulation OD 1.10-0.63 mm (.043-.025 inch).

DEFINITION OF TERMS

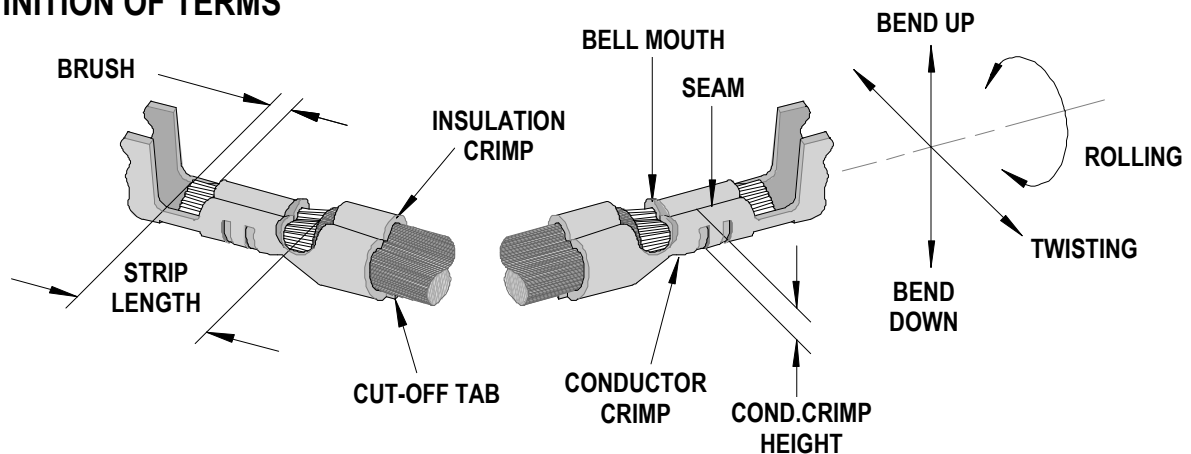

The above terminal drawing is a generic terminal representation. It is not an image of a terminal listed in the scope.

CRIMP SPECIFICATION

Terminal Series No.	Bell mouth		Cut-off Tab Maximum		Conductor Brush	
	mm	In.	mm	In.	mm	In.
43030	0.05-0.40	.002-.016	0.15	.006	0.20-0.80	.008-.031
43031	0.05-0.40	.002-.016	0.15	.006	0.20-0.80	.008-.031
45773	0.05-0.40	.002-.016	0.15	.006	0.20-0.80	.008-.031

Terminal Series No.	Bend up	Bend down	Twist	Roll	Punch Width mm (Ref)				Seam Seam shall not be open and no wire allowed out of the crimping area
	Degree		Degree		Conductor		Insulation		
					mm	In	mm	In	
43030	3	3	4	8	1.10	.043	1.60	.063	
43031	3	3	4	8	1.10	.043	1.60	.063	
45773	3	3	4	8	1.10	.043	1.60	.063	

After crimping, the conductor profile should measure the following.

Terminal Series No.	Wire Size		Conductor Crimp Height		Pull Force Minimum	
	AWG	mm ²	mm	In.	N	Lb.
43030	26	0.12	0.74-0.79	.029-.031	13.4	3.0
	28	0.08	0.71-0.76	.028-.030	8.9	2.0
	30	0.05	0.69-0.74	.027-.029	6.7	1.5
43031	26	0.12	0.74-0.79	.029-.031	13.4	3.0
	28	0.08	0.71-0.76	.028-.030	8.9	2.0
	30	0.05	0.69-0.74	.027-.029	6.7	1.5
45773	26	0.12	0.74-0.79	.029-.031	13.4	3.0
	28	0.08	0.71-0.76	.028-.030	8.9	2.0
	30	0.05	0.69-0.74	.027-.029	6.7	1.5

Pull Force should be measured with no influence from the insulation crimp.

The above specifications are guidelines to an optimum crimp.

PARTS LIST

FineAdjust Applicator 63900-4400				
Item	Order No	Engineering No.	Description	Quantity
Perishable Tooling				
	63900-4470	63900-4470	Tool Kit (All "Y" Items)	REF
1	63444-1116	63444-1116	Conductor Punch	1 Y
2	63445-1122	63445-1122	Conductor Anvil	1 Y
3	63446-1610	63446-1610	Insulation Punch	1 Y
4	63445-1613	63445-1613	Insulation Anvil	1 Y
5	63443-0002	63443-0002	Cut-Off Plunger	1 Y
6	63443-0012	63443-0012	Front Plunger Retainer	1 Y
Other Components (REF 004450)				
7	11-18-4083	60707-8	Feed Guide	1
8	11-24-1067	4996-4	Cut-off Plunger Spring	1
9	11-40-4039	8302-5	Front Plunger Striker	1
10	63443-0009	63443-0009	Front Scrap Chute	1
11	63443-0024	63443-0024	Key	1
12	63443-0090	63443-0090	Wire Stop	1
13	63443-1703	63443-1703	17.30mm Height Spacer	1
14	63443-2216	63443-2216	16.00mm Coarse Spacer	1
15	63443-2302	63443-2302	3.10mm Fine Spacer	1
16	63443-6111	63443-6111	Rear Cover	1
Frame				
17	63800-4901	63800-4901	Top	1
18	63801-3281	63801-3281	Base	1
19	63801-4650	63801-4650	Track	1
Hardware				
20	N/A	N/A	M3 by 6 Long SHCS	2**
21	N/A	N/A	M3 by 6 Long FHCS	1**
22	N/A	N/A	M4 by 6 Long SHCS	2**
23	N/A	N/A	M4 by 12 Long BHCS	2**
24	N/A	N/A	M4 by 50 Long SHCS	2**
25	N/A	N/A	M5 by 12 Long SHCS	1**
26	N/A	N/A	#10-32 by 3/8" Long Flat Point SSS	1**
27	N/A	N/A	#10-32 Hex Jam Nut	1**
** Available from an industrial supply company such as MSC (1-800-645-7270).				

Assembly Drawing

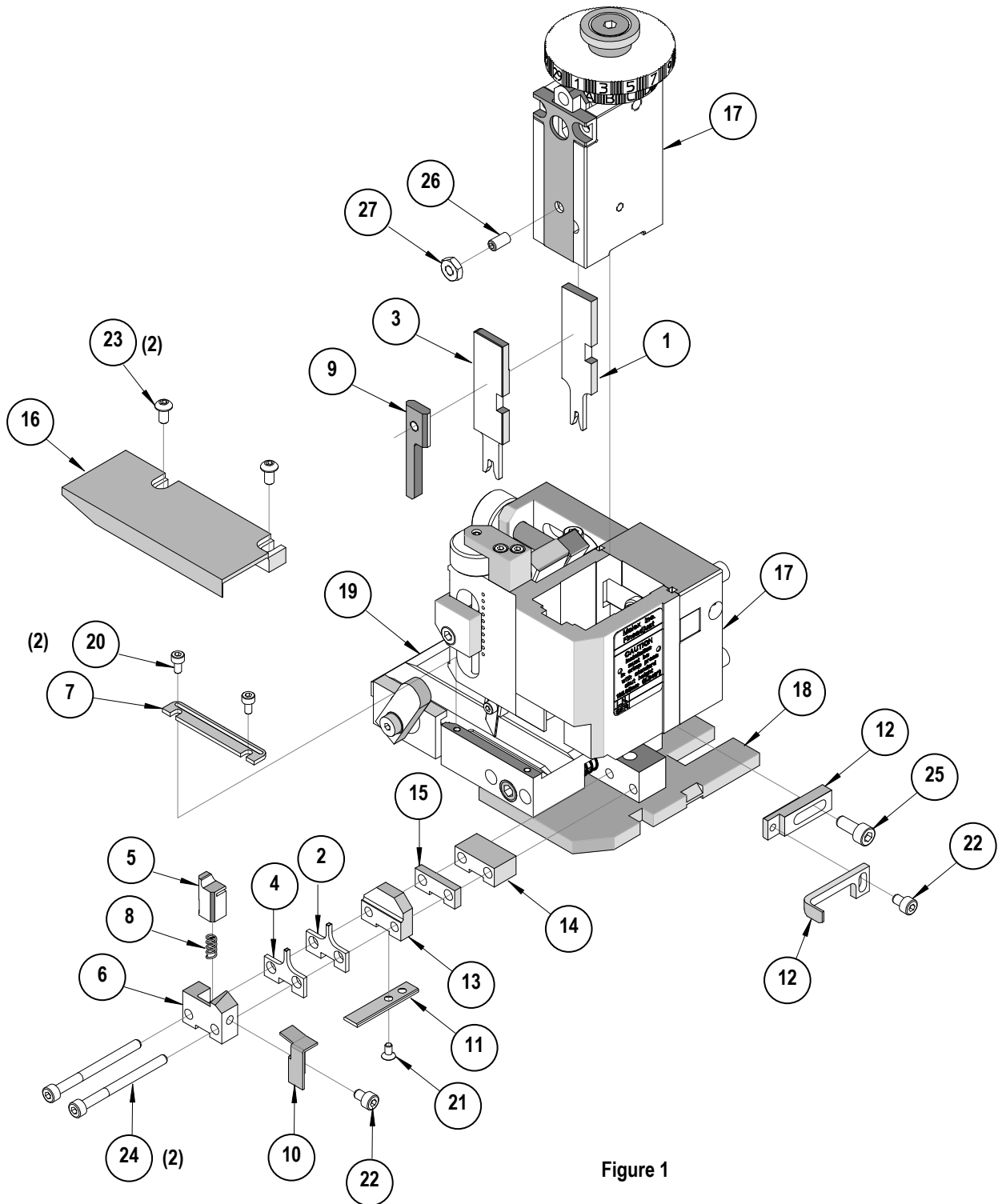

Figure 1

NOTES

1. Molex recommends an extra perishable tooling kit be maintained at your facility.
2. Verify tooling alignment by manually cycling the press and Applicator before crimping under power. Check that all screws are tight.
3. Slugs, Terminals, Dirt and Oil should be kept clear of work area.
4. Wear safety glasses at all times.
5. For recommended maintenance refer to the FineAdjust Manual.

CAUTION: This applicator should only be used in a press with a shut height of 135.8 mm (5.346"). Tooling damage could result at a lower setting.

CAUTION: To prevent injury never operate this Applicator without the guards supplied with the press or wire-processing machine in place. Reference the press or wire processing manufacturer's instruction manual.

CAUTION: Molex crimp specifications are valid only when used with Molex terminals, applicators and tooling.

<http://www.molex.com>

Mouser Electronics

Authorized Distributor

Click to View Pricing, Inventory, Delivery & Lifecycle Information:

[Molex:](#)

[63900-4470](#)