

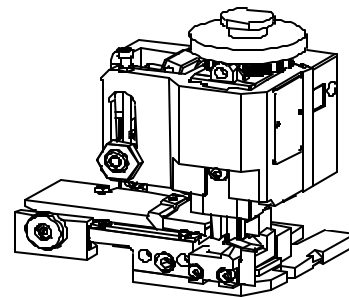

SPECIFICATION SHEET
FineAdjust Applicator
63865-3100
REVISION A



SCOPE

Terminal Series No		Wire Size		Insulation Diameter		Strip Length	
		Awg	(mm ²)	mm	(in)	mm	(in)
33000-1002	Male (tin)	16	(1.27)	2.18-2.34	(.086-.092)	4.70-5.60	(.185-.220)
33011-0004	Male (gold)	16	(1.27)	2.18-2.34	(.086-.092)	4.70-5.60	(.185-.220)

Wire Specs: Wires to be thin wall thickness per Ford's specification MIL135-A1 and MIL123-A

DEFINITION OF TERMS

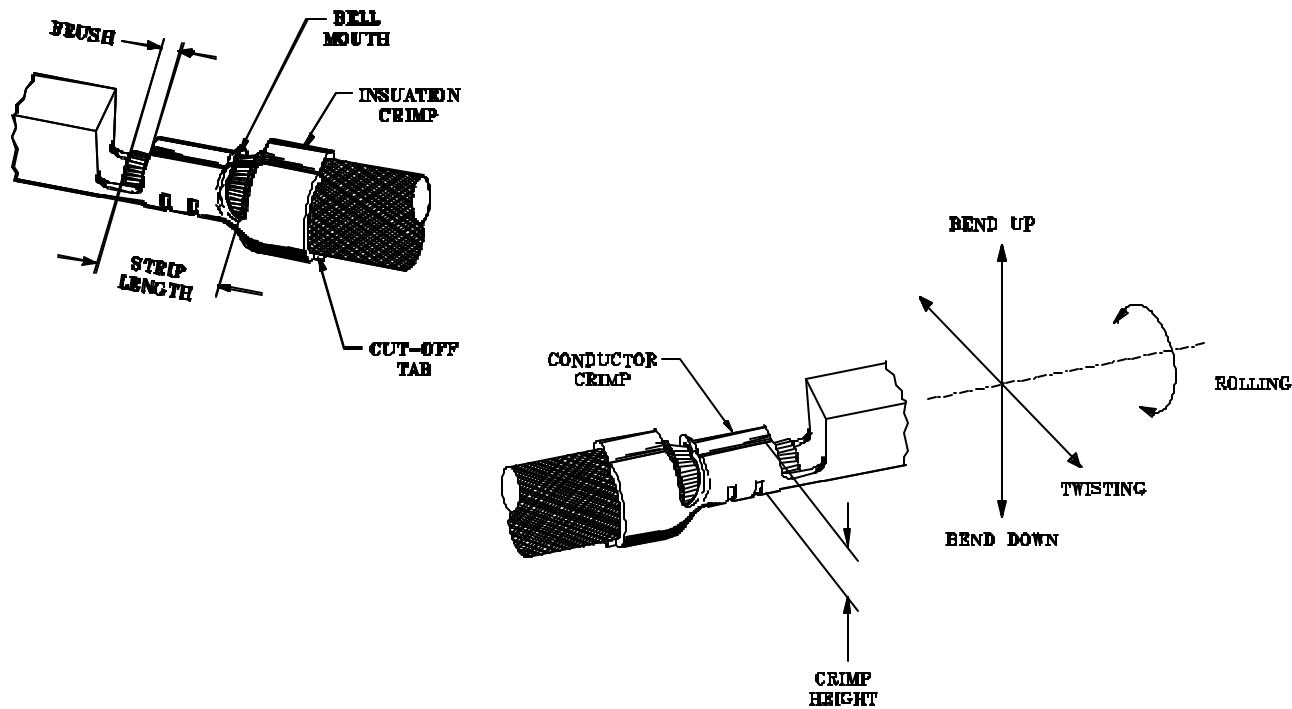

The above terminal drawing is a generic terminal representation. It is not an image of a terminal listed in the scope

SPECIFICATIONS

Terminal Series No.	Bellmouth mm (in)		Cut-Off Tab Max. mm (in)		Conductor Brush mm (in)	
33000-1002	0.25-1.25	(.010-.049)	0.50	(.020)	0.15-0.65	(.006-.026)
33011-0004	0.25-1.25	(.010-.049)	0.50	(.020)	0.15-0.65	(.006-.026)

Terminal Series No.	Bend Up	Bend Down	Twist	Roll	Punch Width mm Conductor Insulation	
	Degree		Degree			
33000-1002	3	3	3	5	2.10	2.55
33011-0004	3	3	3	5	2.10	2.55

The above specifications are guidelines to an optimum crimp.

CONDITIONS

After crimping, the crimp profiles should measure the following.

Terminal Series	Wire Size Awg (mm ²)		Conductor Crimp Height mm (in)		Conductor Crimp Width mm (in)		Pull Force Min N (lbs)	
33000-1002	16	(1.27)	1.30-1.40	(.051-.055)	2.05-2.25	(.081-.089)	120.0	(27.00)
33011-0004	16	(1.27)	1.30-1.40	(.051-.055)	2.05-2.25	(.081-.089)	120.0	(27.00)

Terminal Series	Wire Size Awg (mm ²)		Insulation Crimp Height mm (in)		Insulation Crimp Width mm (in)	
33000-1002	16	(1.27)	2.10-2.30	(.083-.091)	2.50-2.70	(.098-.106)
33011-0004	16	(1.27)	2.10-2.30	(.083-.091)	2.50-2.70	(.098-.106)

Pull Force measured with no influence from the insulation crimp

PARTS LIST

Item Number	Order Number	Eng Number	Description	Qty	Kit Part
1	634570009	634570009	Conductor Punch	1	Y
2	634550008	634550008	Conductor Anvil	1	Y
3	634540011	634540011	Insulation Punch	1	Y
4	634560010	634560010	Insulation Anvil	1	Y
5	634610001	634610001	Cut-Off Plunger	1	Y
6	634430036	634430036	Front Plunger Retainer	1	Y
7	637000539	637000539	Cut-Off Plunger Spring	1	
8	634433160	634433160	Front Plunger Striker	1	
9	634430021	634430021	Lower Tooling Key	1	
10	634436013	634436013	Rear Cover	1	
11	11-18-4094	60709A111	Front Cover	1	
12	634432506	634432506	Anvil Mount	1	
13	11-18-4080	60707-5	Wire Stop	1	
14	634430009	634430009	Scrap Chute	1	
15	638013100	638013100	Wide Track FineAdjust	1	
49	634590001	634590001	Wide Terminal Track	1	
70	638653170	638653170	Tool Kit (All "Y" Items)	0	

NOTES

1. We recommend an extra perishable tooling kit be maintained at your facility.
2. Verify tooling alignment by manually cycling the press and Applicator before crimping under power.
3. Slugs , Terminals, Dirt and Oil should be kept clear of work area.
4. This Applicator should only be used in a press with a shut height of 135.8 mm (5.346"). Tooling damage could result at a lower setting.
5. **** CAUTION**** To prevent injury never operate this Applicator without the guarding supplied with the press or wire processing machine in place. Reference the press or wire processing manufacturer's instruction manual.
6. Wear safety glasses at all times.

ASSEMBLY DRAWING

The drawing below is a generic drawing representation. Some detail may not be shown. The FineAdjust applicator assembly and parts list can be found in the FineAdjust manual.

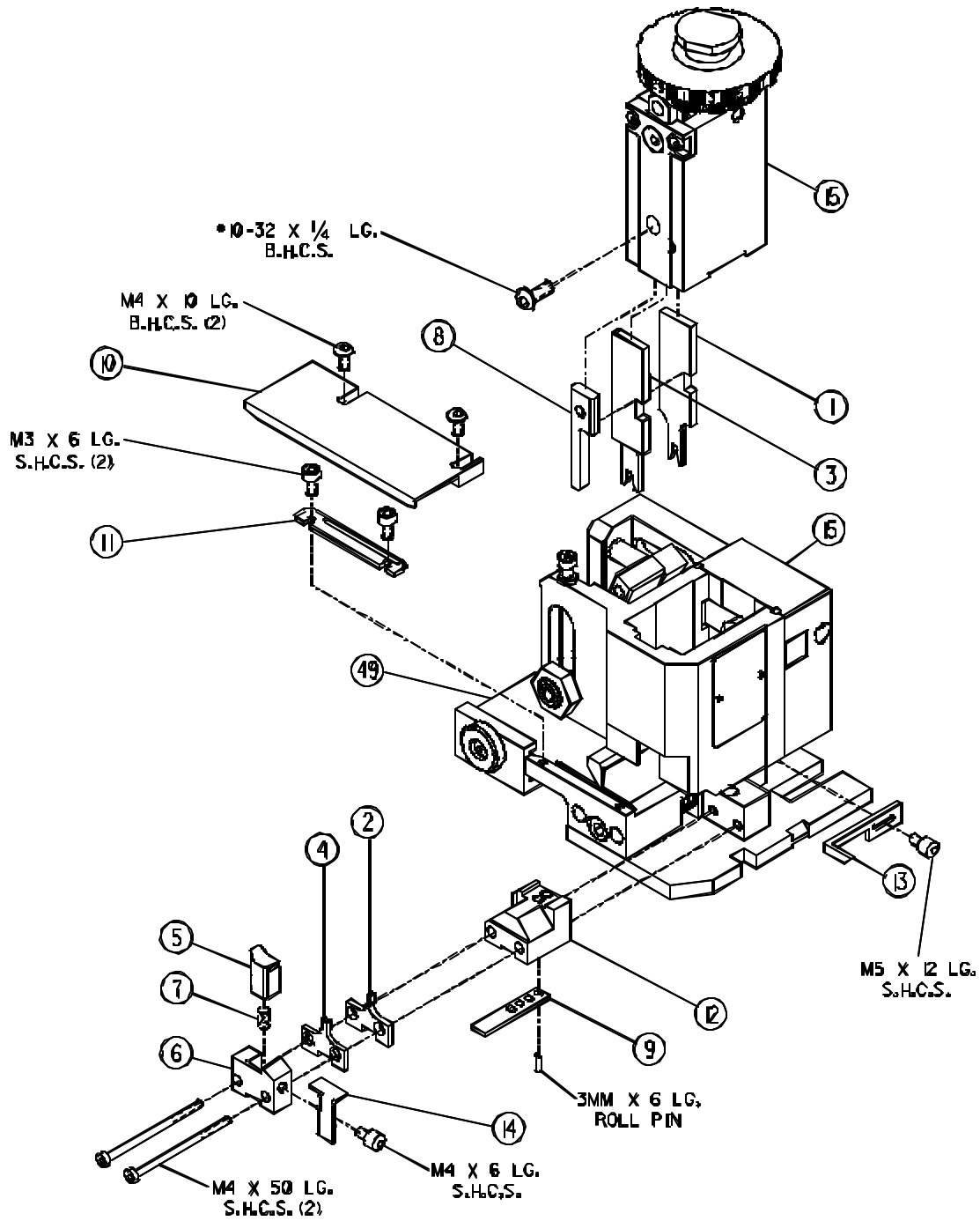

Mouser Electronics

Authorized Distributor

Click to View Pricing, Inventory, Delivery & Lifecycle Information:

[Molex:](#)

[63865-3170](#)