

THIS DRAWING IS UNPUBLISHED. RELEASED FOR PUBLICATION  
 © COPYRIGHT BY TYCO ELECTRONICS CORPORATION. ALL RIGHTS RESERVED.

LOC	DIST	REVISIONS					
ES	00	P	LTR	DESCRIPTION	DATE	DWN	APVD
			B3	REVISED ECR-10-000344	07JAN2010	K.L.	S.Y

NOTES:

- 1 MATERIAL: CONTACT: COPPER ALLOY.  
HOUSING: THERMOPLASTIC BLACK LCP OR EQUIVALENT, UL 94V-0.
- 2 FINISH: 15 MICROINCH (0.38 MICRON) GOLD PLATING ON CONTACT AREA, GOLD FLASH PLATING ON SOLDER AREA, OVER 50 MICROINCH (1.27 MICRON) NICKEL PLATING OVERALL.
- 3 PRODUCT TO BE PACKAGED IN ANTI-STATIC TAPE AND REEL.
- 4 NORMAL FORCE IS 80g MIN. WHEN A CONTACT BE PRESSED TO HOUSING'S SURFACE.
- 5 CONTACT SHOULD BE PRESSED TO THIS AREA WHEN APPLICATION..

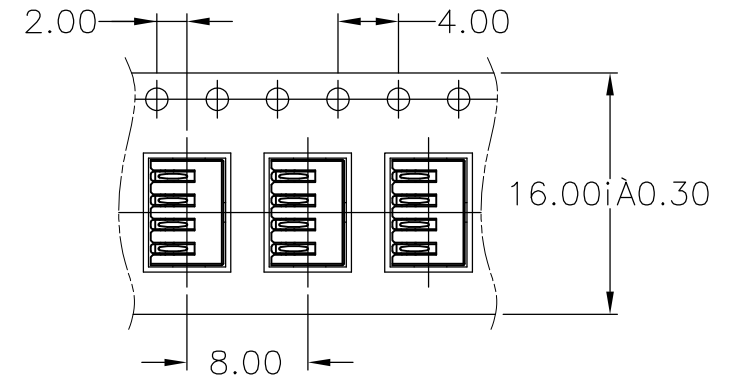
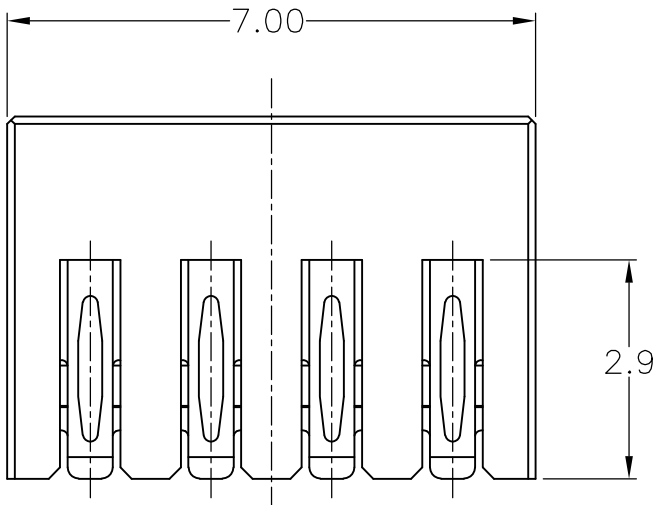

DIRECTION REEL OFF BY CUSTOMER

Tape material: PS black conductive  
 Reel diameter: 330mm  
 Components / reel: 1500pcs

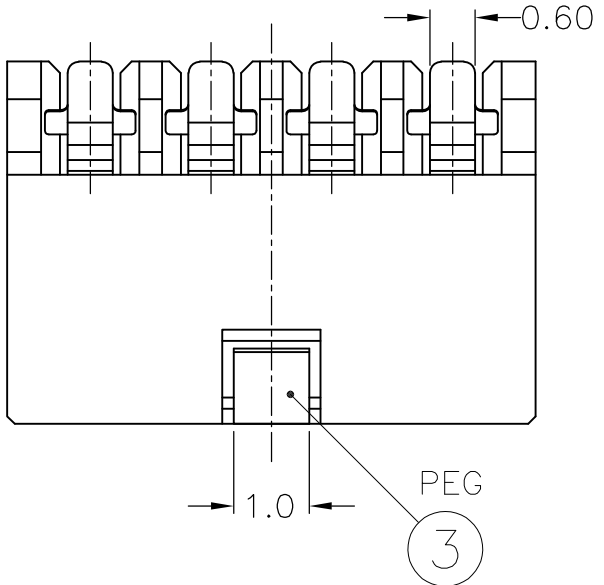
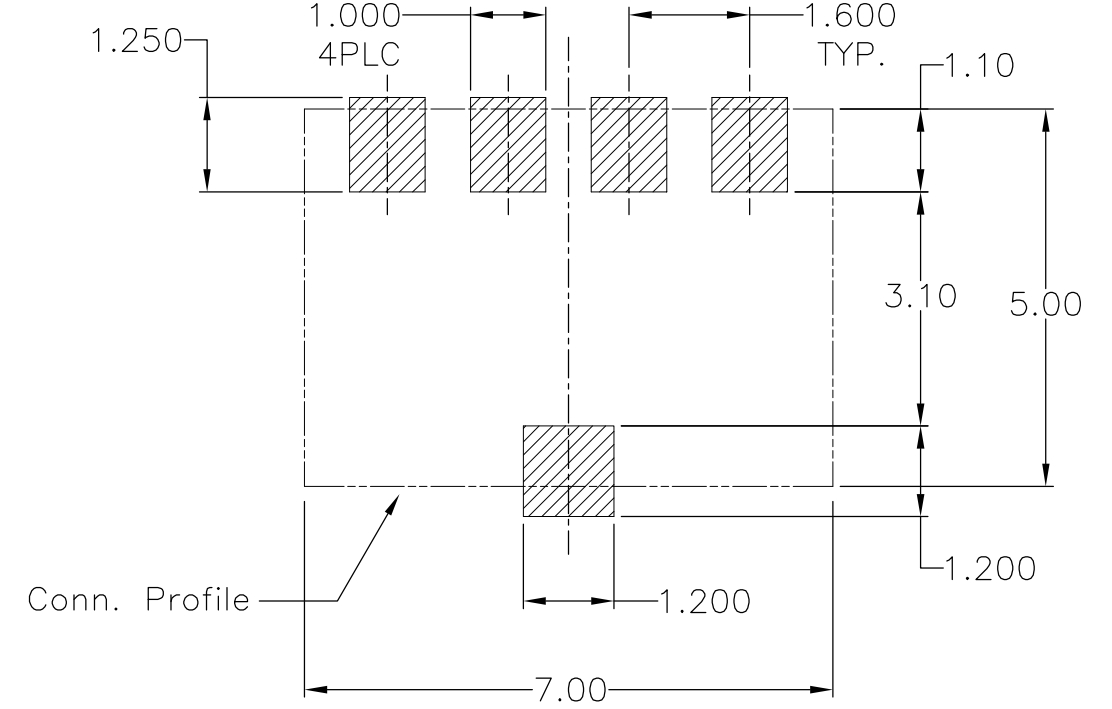
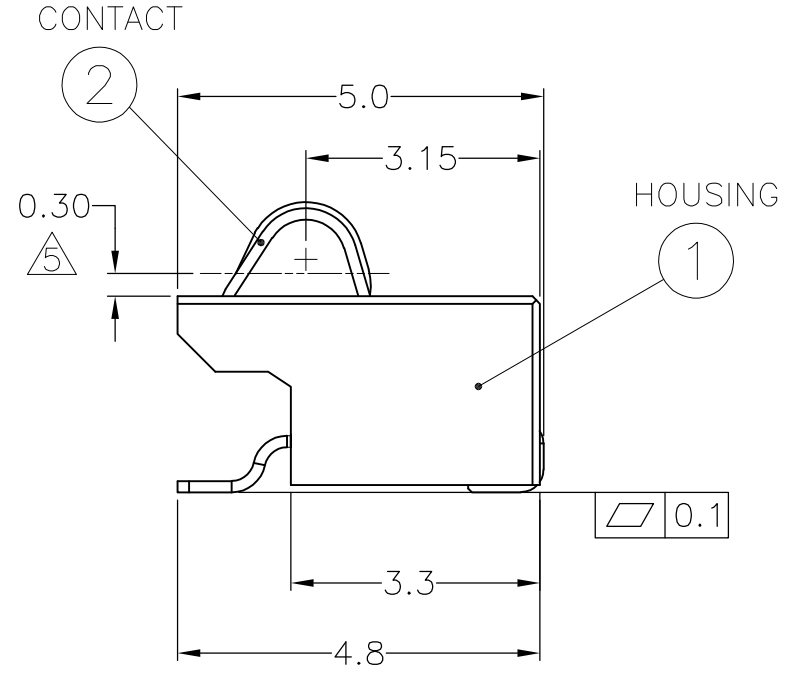
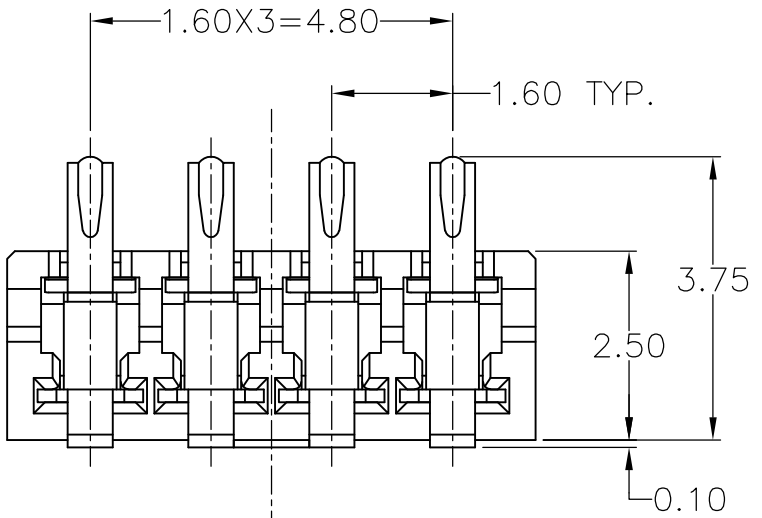

P/N: 292331-1 AS SHOWN

RECOMMENDED PCB LAYOUT

THIS DRAWING IS A CONTROLLED DOCUMENT.		DWN	10AUG2004	 Tyco Electronics Corporation Shanghai, P.R.China, 200233
DIMENSIONS: mm		CHK	10AUG2004	
TOLERANCES UNLESS OTHERWISE SPECIFIED:		APVD	10AUG2004	
0 PLC ± - 1 PLC ± 0.2 2 PLC ± 0.10 3 PLC ± 0.050 4 PLC ± - ANGLES ± -		NAME		
MATERIAL		PRODUCT SPEC	BATTERY 4P SMT 1.6MM PITCH ASSEMBLY CONNECTOR	
FINISH		APPLICATION SPEC	-	
		WEIGHT	-	
		CUSTOMER DRAWING	SCALE	10:1
			SHEET	1 OF 4
			REV	B3

THIS DRAWING IS UNPUBLISHED. RELEASED FOR PUBLICATION  
 © COPYRIGHT BY TYCO ELECTRONICS CORPORATION. ALL RIGHTS RESERVED.

LOC	DIST	REVISIONS					
ES	00	P	LTR	DESCRIPTION	DATE	DWN	APVD
				SEE SHEET 1			

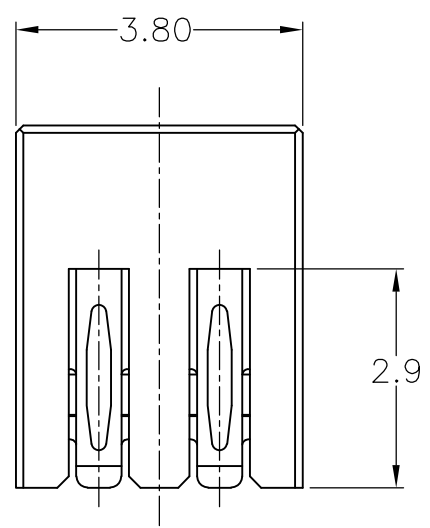

NOTES:

- MATERIAL: CONTACT: COPPER ALLOY.  
HOUSING: THERMOPLASTIC BLACK LCP OR EQUIVALENT, UL 94V-0.
  - FINISH: 15 MICRINCH (0.38 MICRON) GOLD PLATING ON CONTACT AREA, GOLD FLASH PLATING ON SOLDER AREA, OVER 50 MICRINCH (1.27 MICRON) NICKEL PLATING OVERALL.
  - PRODUCT TO BE PACKAGED IN ANTI-STATIC TAPE AND REEL.
  - NORMAL FORCE IS 80g MIN. WHEN A CONTACT BE PRESSED TO HOUSING'S SURFACE.
- ⚠ CONTACT SHOULD BE PRESSED TO THIS AREA WHEN APPLICATION..

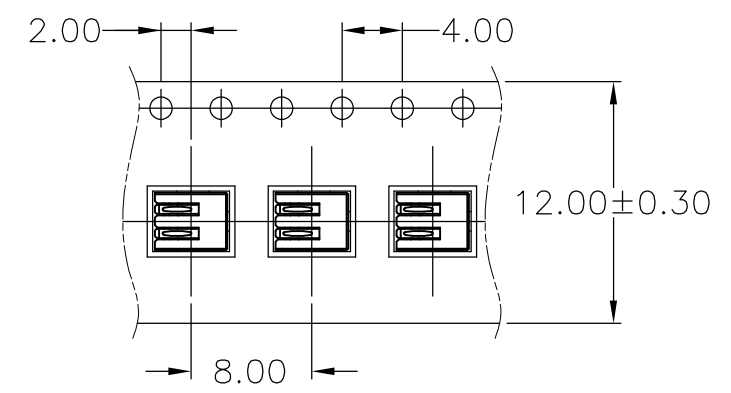

DIRECTION REEL OFF BY CUSTOMER

Tape material: PS black conductive  
 Reel diameter: 330mm  
 Components / reel: 1500pcs

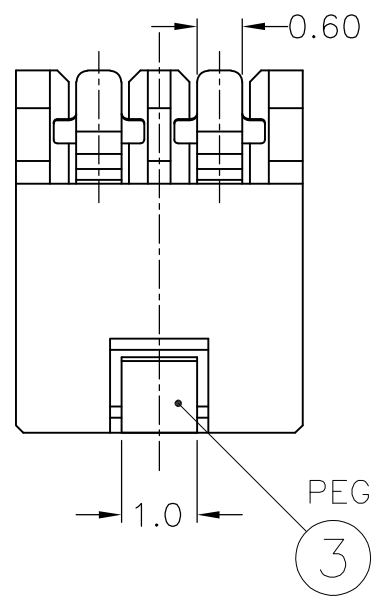
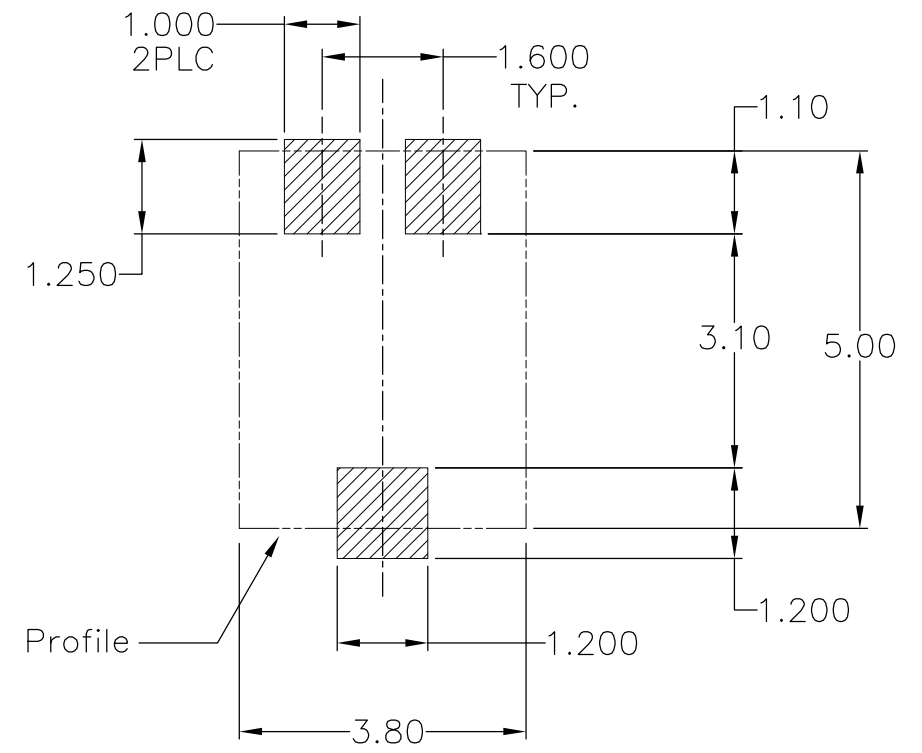
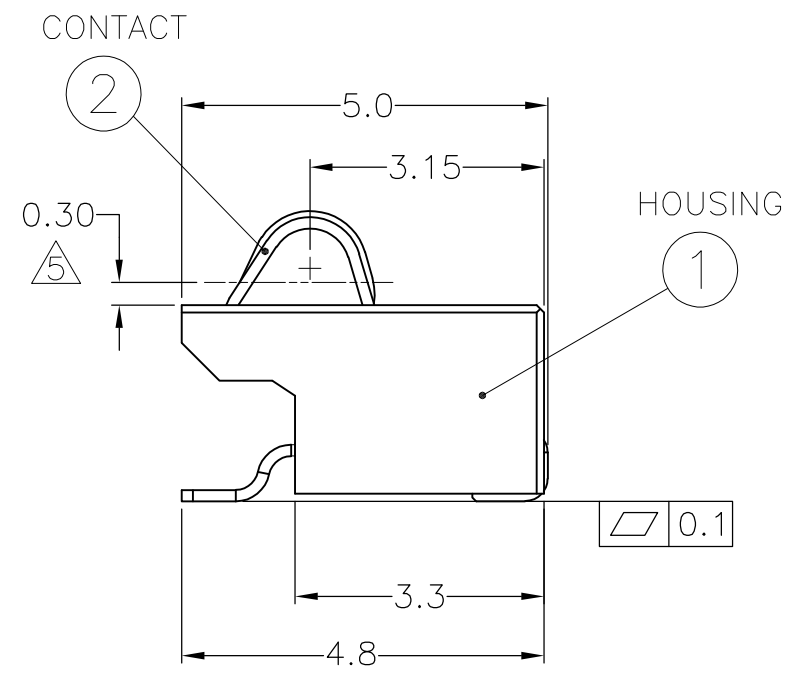
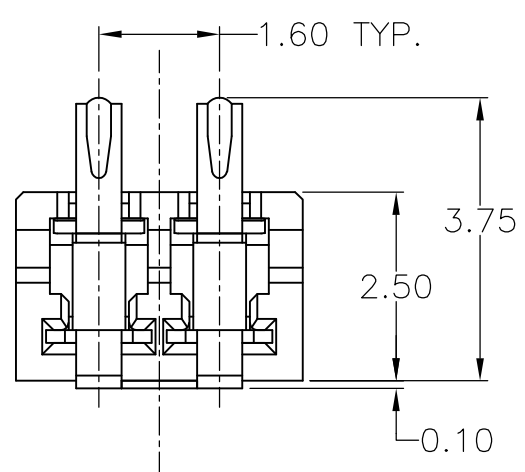

P/N: 292331-2 AS SHOWN(NO TOOLED)

RECOMMENDED PCB LAYOUT

THIS DRAWING IS A CONTROLLED DOCUMENT.		DWN Ivanov Wang 10AUG2004	Tyco Electronics Corporation Shanghai, P.R.China, 200233	
DIMENSIONS: mm		CHK Steven Yao 10AUG2004	BATTERY 2P SMT 1.6MM PITCH ASSEMBLY CONNECTOR	
TOLERANCES UNLESS OTHERWISE SPECIFIED:		APVD Ikuo Enomoto 10AUG2004	NAME	
0 PLC ± -		PRODUCT SPEC	-	
1 PLC ± 0.2		APPLICATION SPEC	-	
2 PLC ± 0.10		WEIGHT	-	
3 PLC ± 0.050		SIZE A3 CAGE CODE 00779 DRAWING NO C-292331 RESTRICTED TO -		
4 PLC ± -		SCALE 10:1 SHEET 2 OF 4 REV B3		
ANGLES ± -		CUSTOMER DRAWING		
FINISH				

THIS DRAWING IS UNPUBLISHED. RELEASED FOR PUBLICATION  
 © COPYRIGHT - BY TYCO ELECTRONICS CORPORATION. ALL RIGHTS RESERVED.

LOC	DIST	REVISIONS					
ES	00	P	LTR	DESCRIPTION	DATE	DWN	APVD
		-		SEE SHEET 1	-	-	-

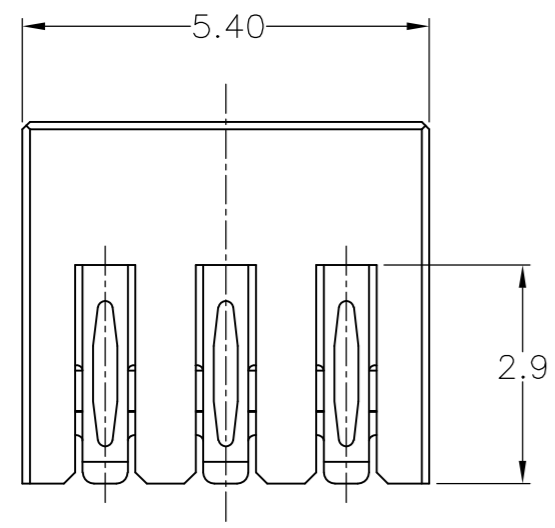

- NOTES:
- MATERIAL: CONTACT: COPPER ALLOY.  
HOUSING: THERMOPLASTIC BLACK LCP OR EQUIVALENT, UL 94V-0.
  - FINISH: 15 MICROINCH (0.38 MICRON) GOLD PLATING ON CONTACT AREA, GOLD FLASH PLATING ON SOLDER AREA, OVER 50 MICROINCH (1.27 MICRON) NICKEL PLATING OVERALL.
  - PRODUCT TO BE PACKAGED IN ANTI-STATIC TAPE AND REEL.
  - NORMAL FORCE IS 80g MIN. WHEN A CONTACT BE PRESSED TO HOUSING'S SURFACE.
- ⚠ CONTACT SHOULD BE PRESSED TO THIS AREA WHEN APPLICATION..

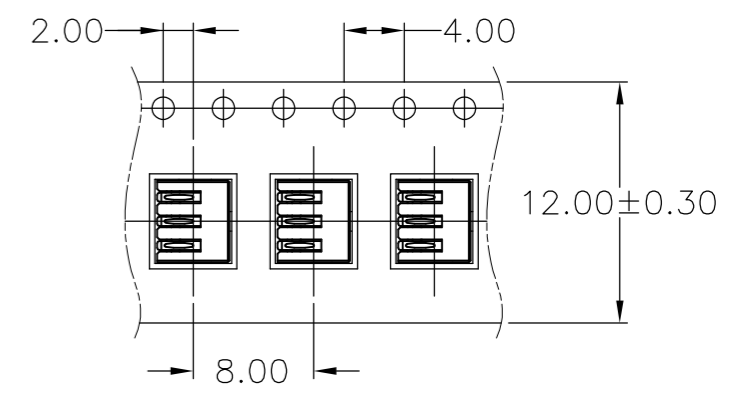

DIRECTION REEL OFF BY CUSTOMER

Tape material: PS black conductive  
 Reel diameter: 330mm  
 Components / reel: 1500pcs

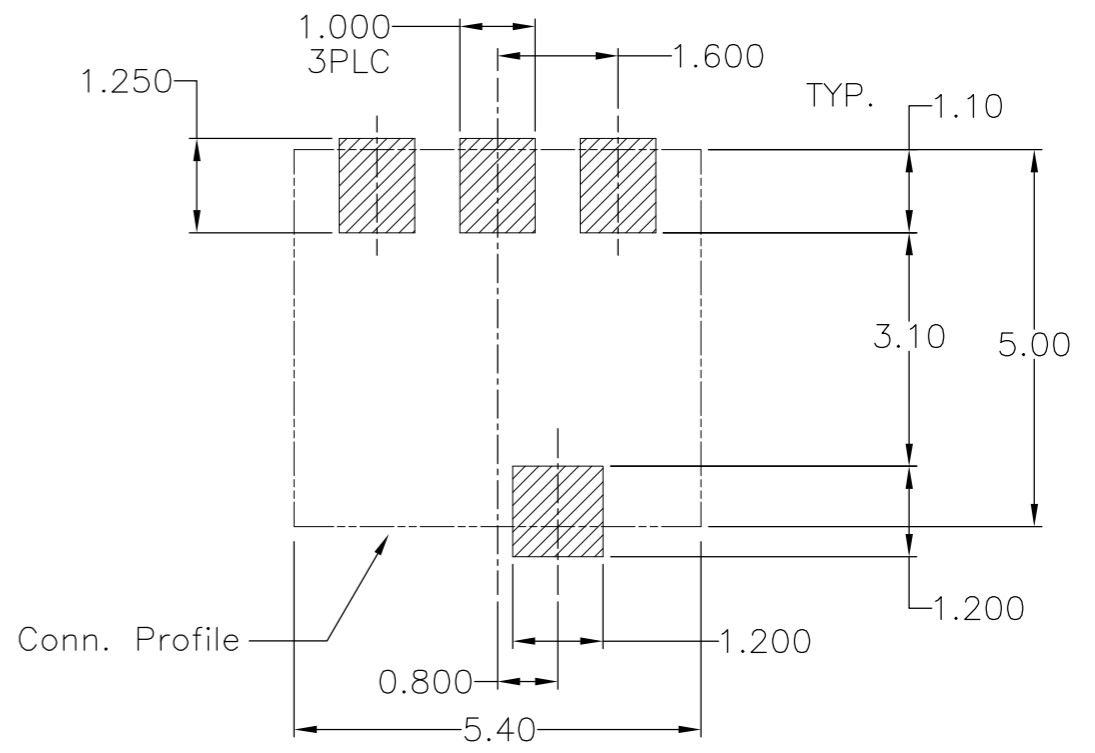
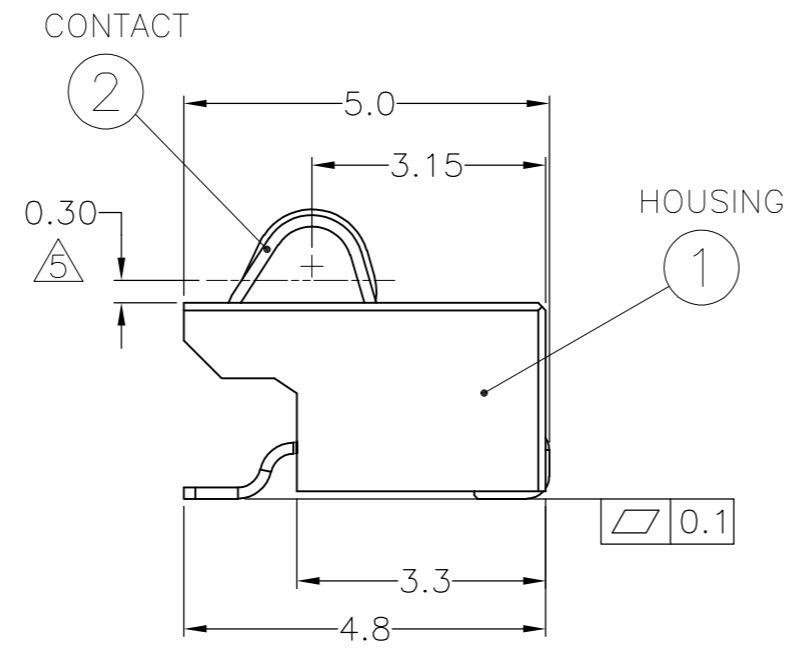
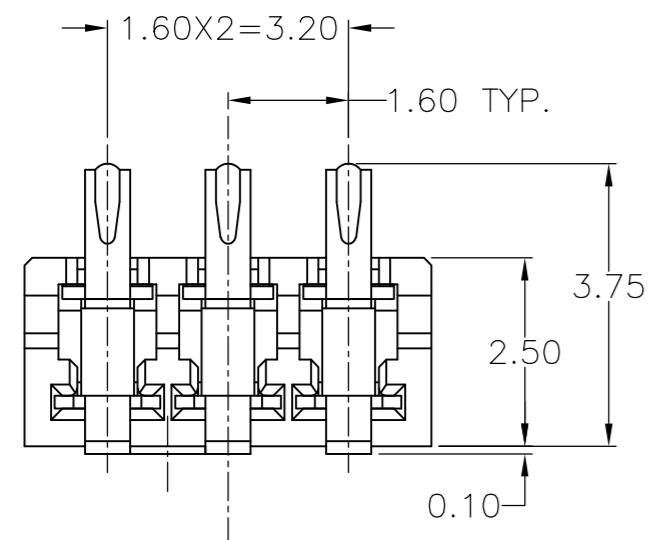

RECOMMENDED PCB LAYOUT

P/N: 292331-3 AS SHOWN

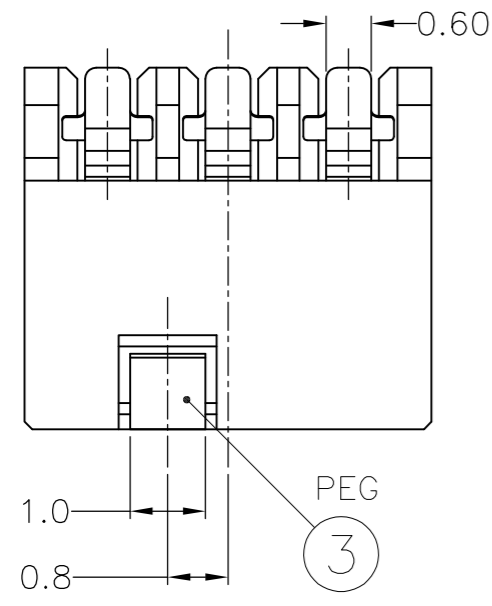

THIS DRAWING IS A CONTROLLED DOCUMENT.		DWN Ivanov Wang 10AUG2004	Tyco Electronics Corporation Shanghai, P.R.China, 200233	
DIMENSIONS: mm		CHK Steven Yao 10AUG2004	NAME	
TOLERANCES UNLESS OTHERWISE SPECIFIED:		APVD Ikuo Enomoto 10AUG2004	BATTERY 3P SMT 1.6MM PITCH ASSEMBLY CONNECTOR	
0 PLC ± -		PRODUCT SPEC	SIZE	RESTRICTED TO
1 PLC ± 0.2		APPLICATION SPEC	CAGE CODE	
2 PLC ± 0.10		WEIGHT	DRAWING NO	
3 PLC ± 0.050		CUSTOMER DRAWING	A3 00779	
4 PLC ± -		SCALE	C=292331	
ANGLES ± -		SCALE	10:1	SHEET 3 OF 4
FINISH		REV	B3	

THIS DRAWING IS UNPUBLISHED. RELEASED FOR PUBLICATION  
 © COPYRIGHT BY TYCO ELECTRONICS CORPORATION. ALL RIGHTS RESERVED.

LOC	DIST	REVISIONS					
ES	00	P	LTR	DESCRIPTION	DATE	DWN	APVD
				SEE SHEET 1			

NOTES:

- MATERIAL: CONTACT: COPPER ALLOY.  
HOUSING: THERMOPLASTIC BLACK LCP OR EQUIVALENT, UL 94V-0.
  - FINISH: 15 MICROINCH (0.38 MICRON) GOLD PLATING ON CONTACT AREA, GOLD FLASH PLATING ON SOLDER AREA, OVER 50 MICROINCH (1.27 MICRON) NICKEL PLATING OVERALL.
  - PRODUCT TO BE PACKAGED IN ANTI-STATIC TAPE AND REEL.
  - NORMAL FORCE IS 80g MIN. WHEN A CONTACT BE PRESSED TO HOUSING'S SURFACE.
- ⚠ CONTACT SHOULD BE PRESSED TO THIS AREA WHEN APPLICATION..

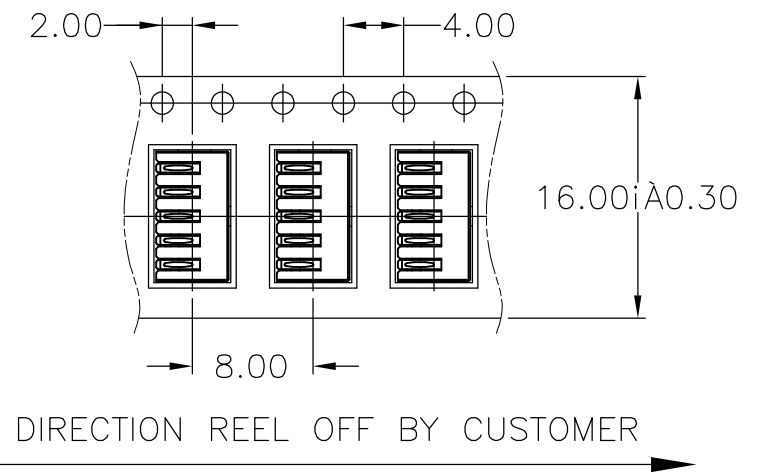
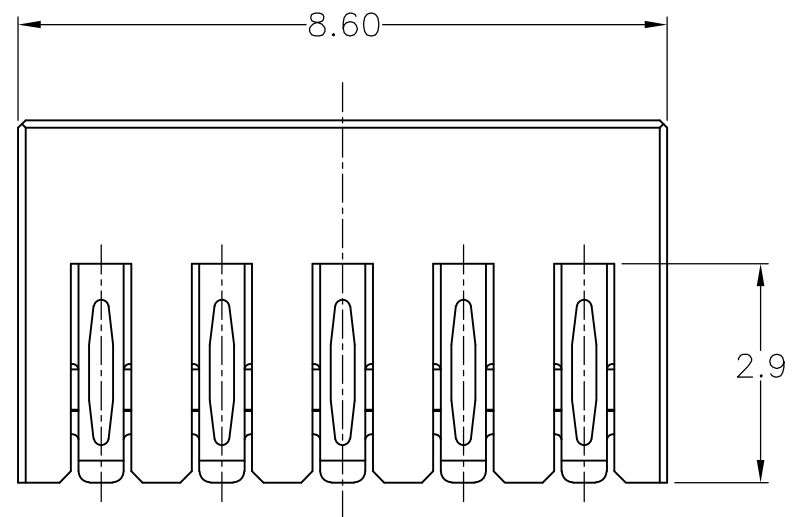

Tape material: PS black conductive  
 Reel diameter: 330mm  
 Components / reel: 1500pcs

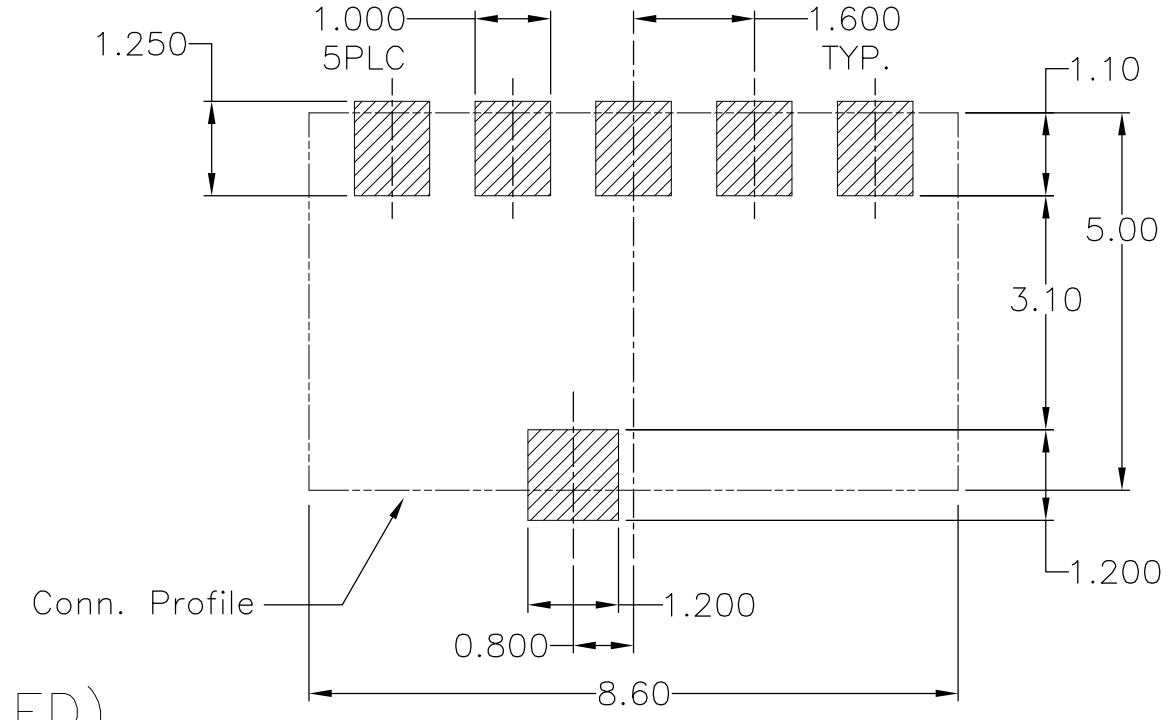
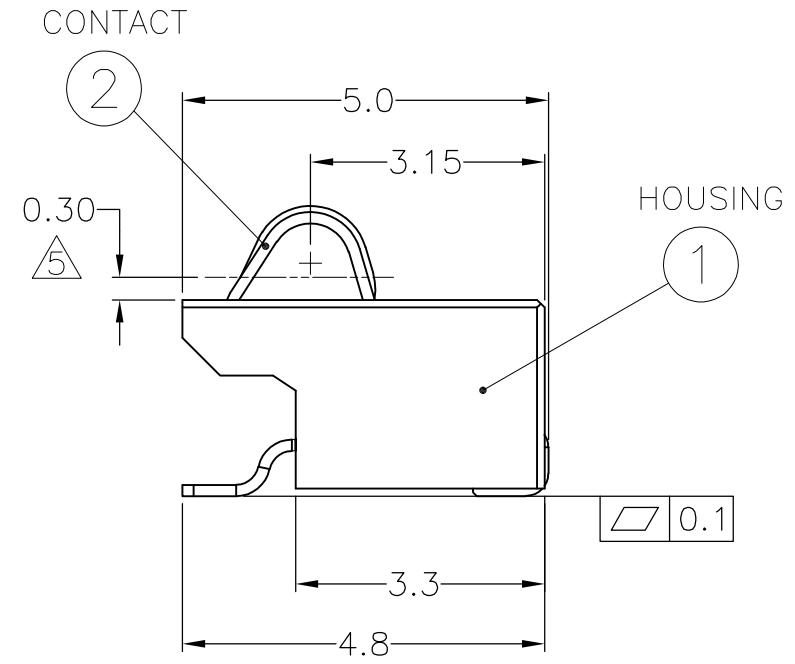
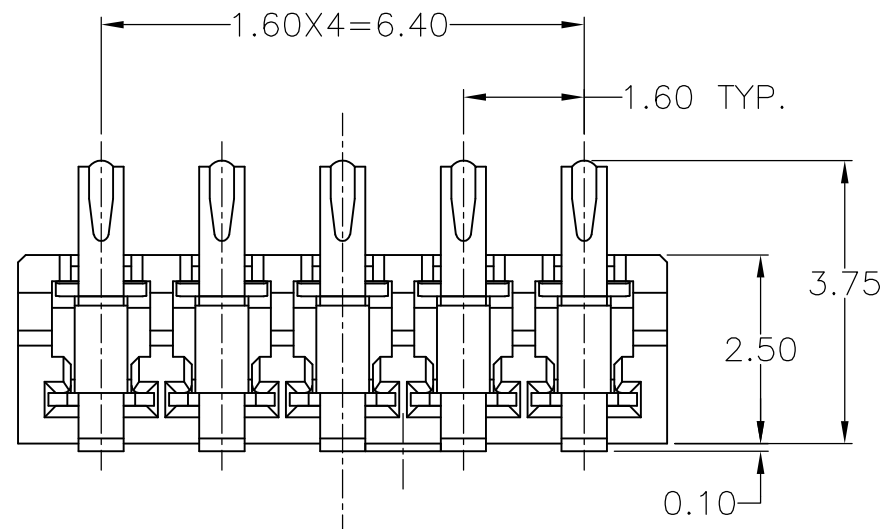

P/N: 292331-5 AS SHOWN(NO TOOLED)

RECOMMENDED PCB LAYOUT

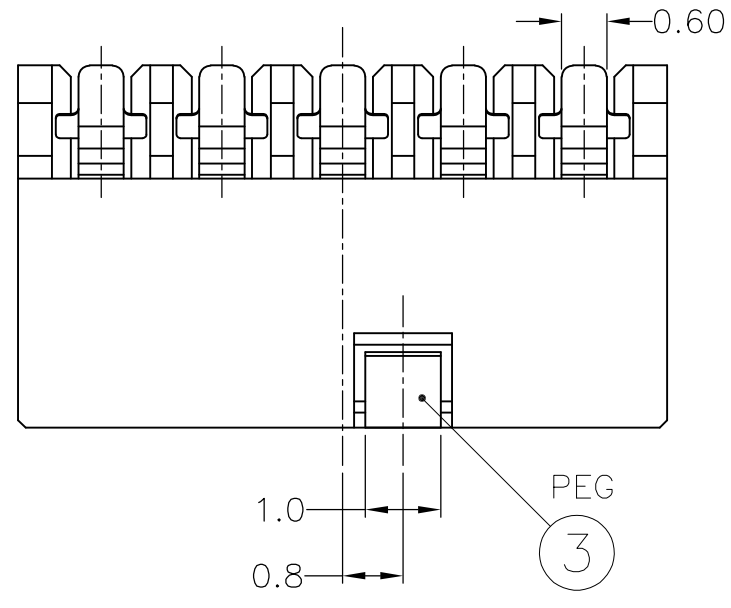

THIS DRAWING IS A CONTROLLED DOCUMENT.		DWN	Ivanov Wang	10AUG2004	Tyco Electronics Corporation Shanghai, P.R.China, 200233
DIMENSIONS: mm		CHK	Steven Yao	10AUG2004	
TOLERANCES UNLESS OTHERWISE SPECIFIED:		APVD	Ikuo Enomoto	10AUG2004	
0 PLC ± - 1 PLC ± 0.2 2 PLC ± 0.10 3 PLC ± 0.050 4 PLC ± - ANGLES ± - FINISH		PRODUCT SPEC		NAME	
MATERIAL		APPLICATION SPEC		BATTERY 5P SMT 1.6MM PITCH ASSEMBLY CONNECTOR	
		WEIGHT		SIZE	
		CUSTOMER DRAWING		A3 00779 C-292331	
		SCALE		RESTRICTED TO	
		10:1		-	
		SHEET		REV	
		4 OF 4		B3	

# Mouser Electronics

Authorized Distributor

Click to View Pricing, Inventory, Delivery & Lifecycle Information:

[TE Connectivity:](#)

[292331-3](#)