

THIS DRAWING IS UNPUBLISHED. RELEASED FOR PUBLICATION
 © COPYRIGHT - By - ALL RIGHTS RESERVED.

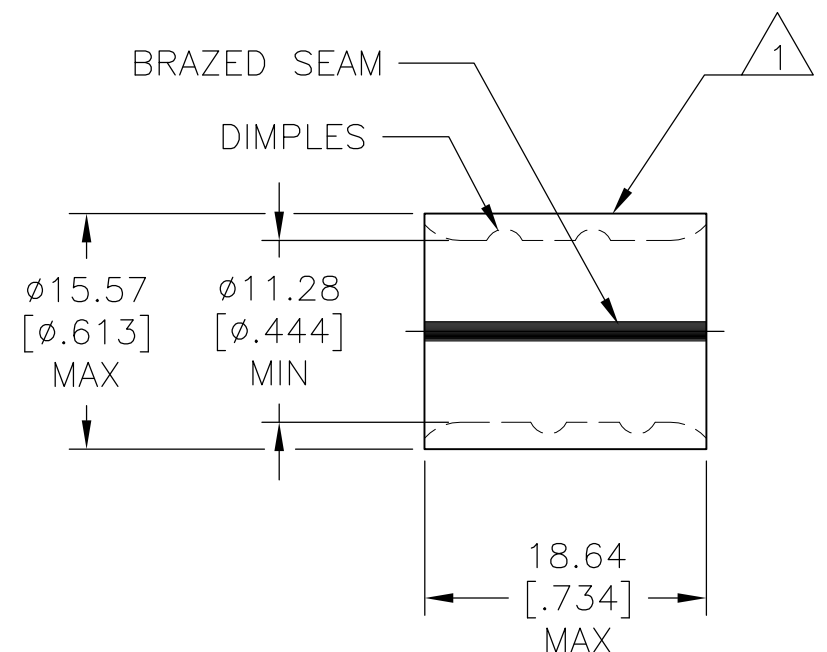

REVISIONS				
P	LTR	DESCRIPTION	DATE	APVD
	H1	REVISED PER ECR-17-000959	24FEB2017	RS DR

AMP WIRE RANGE	 Listed FILE E13288	 LR7189 Certified
1/0 AWG SOLID OR STRANDED	1/0 AWG SOLID OR STRANDED	1/0 AWG SOLID OR STRANDED

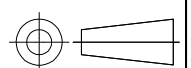

- 1 STAMP AMP 1/0W* 100
LOCATE APPROX AS SHOWN.
- 2 MATERIAL THK.: 1.78±0.08[.070±.003].
- 3 TIN PL 0.00254 [.000100] MIN. EXT. THK. PER ASTM B545.
- 4 NOTE DELETED.
- 5 NOTE DELETED.
- 6 STAMP FOR MANUFACTURING LOCATION OR CODE PERMISSIBLE.
- 7 COPPER PER ASTM B-152, ANNEALED.
- 8 NOTE DELETED.
- 9 0.00254 [.000100] MIN. EXT. THK. TIN/LEAD (60/40) PLATE
PER SAE-AMS-P-81728.
- 10 NOT UL OR CSA LISTED.
- 11 NICKEL PLATE 0.00762[.000300] MIN. EXT. THK. PER
SAE AMS QQ-N-290.

PRELIMINARY	343°C[650°F]	11	50	LOOSE PIECE	10 36946-3
	170°C[338°F]	9	100	LOOSE PIECE	10 36946-2
	170°C[338°F]	3	50	LOOSE PIECE	36946
	MAX. OPERATING TEMPERATURE	FINISH	QTY.	PACKAGE TYPE	PART NO.

AMP INCORPORATED CUSTOMER SERVICE SYSTEMS		MAX RECOMMENDED OPERATING TEMPERATURE: SEE TABLE	THIS DRAWING IS A CONTROLLED DOCUMENT.		DWN DK SCHRUM 5/21/93	 TE Connectivity				
FOR ADDITIONAL PRODUCT INFORMATION OR COPIES OF DRAWINGS AND TECHNICAL DOCUMENTS	PRODUCT INFORMATION CENTER 1-800-522-6752	VOLTAGE RATING: N/A	DIMENSIONS: mm [INCHES]	TOLERANCES UNLESS OTHERWISE SPECIFIED:	CHK RD HEIM 5/21/93					NAME SPLICE, PARALLEL, SOLISTRAND
FOR APPLICATION TOOLING INFORMATION	TOOLING ASSISTANCE CENTER 1-800-722-1111	CIRCULAR MIL AREA: 42.4-60.6mm²[83,700-119,500] SOLID OR STRANDED		0 PLC ± - 1 PLC ± - 2 PLC ± 0.20[.008] 3 PLC ± - 4 PLC ± - ANGLES ± -	APVD CR RHOADS 5/21/93	APPLICATION SPEC	SIZE	CAGE CODE	DRAWING NO	
FOR ORDER ENTRY	1-800-526-5142	THIS DRAWING IS A CONTROLLED DOCUMENT FOR AMP INCORPORATED. IT IS SUBJECT TO CHANGE AND THE CONTROLLING ENGINEERING ORGANIZATION SHOULD BE CONTACTED FOR THE LATEST REVISION.	MATERIAL 	FINISH SEE TABLE	WEIGHT -		A3	00779	C-36946	
					CUSTOMER DRAWING		SCALE 2:1	SHEET 1 OF 1	REV H1	