

- NOTES:
1. MINIMUM CONTACT PUSHOUT: 1.5 LBS.
 2. FOR A 1 POSITION SINGLE ROW ALL SPACERS ARE TO BE TSW-XX-S.
 3. SPACERS SHALL BE ASSEMBLED AS SHOWN WITH SNAP GROOVES AWAY FROM SSW BODY.
 4. MAXIMUM ALLOWABLE BOW .003[0.08] INCH/INCH AFTER ASSEMBLY
 5. DO NOT USE DSB SPACER BODY FOR THIS OPTION.
 6. MAXIMUM CUT FLASH : .010[0.25]; MAXIMUM CUT FLASH ON TAIL SIDE: .020[0.51] NOT TO EXTEND BELOW STANDOFFS

DO NOT SCALE FROM THIS PRINT

CONTACT STYLE
 SQUARE TAIL: USE C-15-X-X
 LOW INSERTION FORCE: C-60-X-X
 (SEE TABLE 1, SHT 2)

NO. OF POSITIONS
 POSITIONS 01 THRU 36
 (SEE FIG1)
 FOR A ONE POSITION
 SINGLE ROW SEE NOTE 2

LEAD STYLE
 (SEE TABLE 1, SHT 2)

PLATING SPECIFICATION

- G: 20µ" GOLD IN CONTACT AREA, 3µ" GOLD TAIL
- T: MATTE TIN CONTACT AND TAIL
- S: 30µ" SELECTIVE GOLD IN CONTACT AREA, MATTE TIN TAIL
- H: 30µ" HEAVY GOLD IN CONTACT AREA, 3µ" GOLD TAIL
- L: 10µ" SELECTIVE LIGHT GOLD IN CONTACT AREA, MATTE TIN TAIL

METAL WASHER OPTION
 #* -H-MW: (SEE FIG 3, SHT 2)
 (N/A ON TRIPLE ROW)
 (.300 [7.62] MAX TAIL)
 (AVAILABLE ON POS
 -02 THRU -32 ONLY)

LOCKING LEAD OPTION
 -LL (SEE FIG 2, SHT 2)
 (N/A ON 1 OR 2 POSITION
 SINGLE ROW)

POLARIZATION OPTION
 INDICATES POSITION (SEE FIG 4, SHT 2)

ROW SPECIFICATION (SEE TABLE 1, SHT 2)
 -S: SINGLE (USE SSW-50-S)
 -D: DOUBLE (USE SSW-50-D)
 -T: TRIPLE (USE SSW-50-T)

#-MW OPTION, DO NOT DESIGN IN. SAMTEC WILL ONLY SUPPORT EXISTING BUSINESS 2/12/02

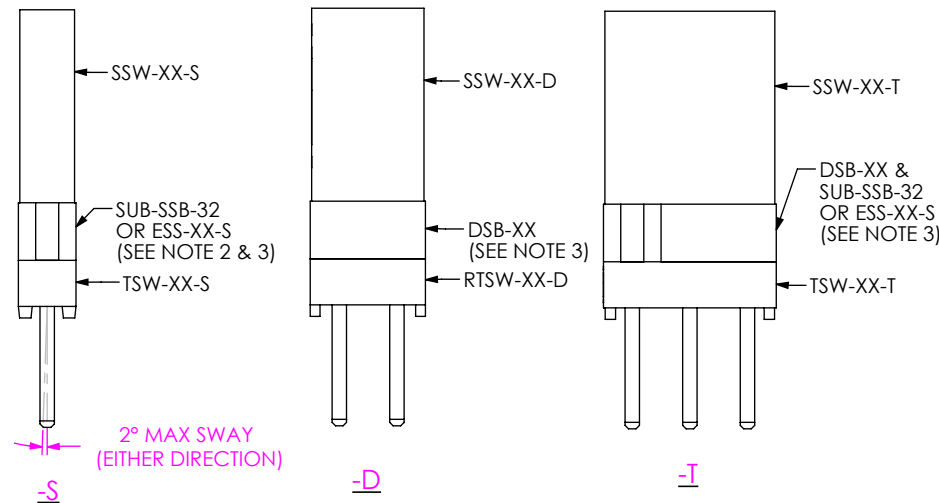
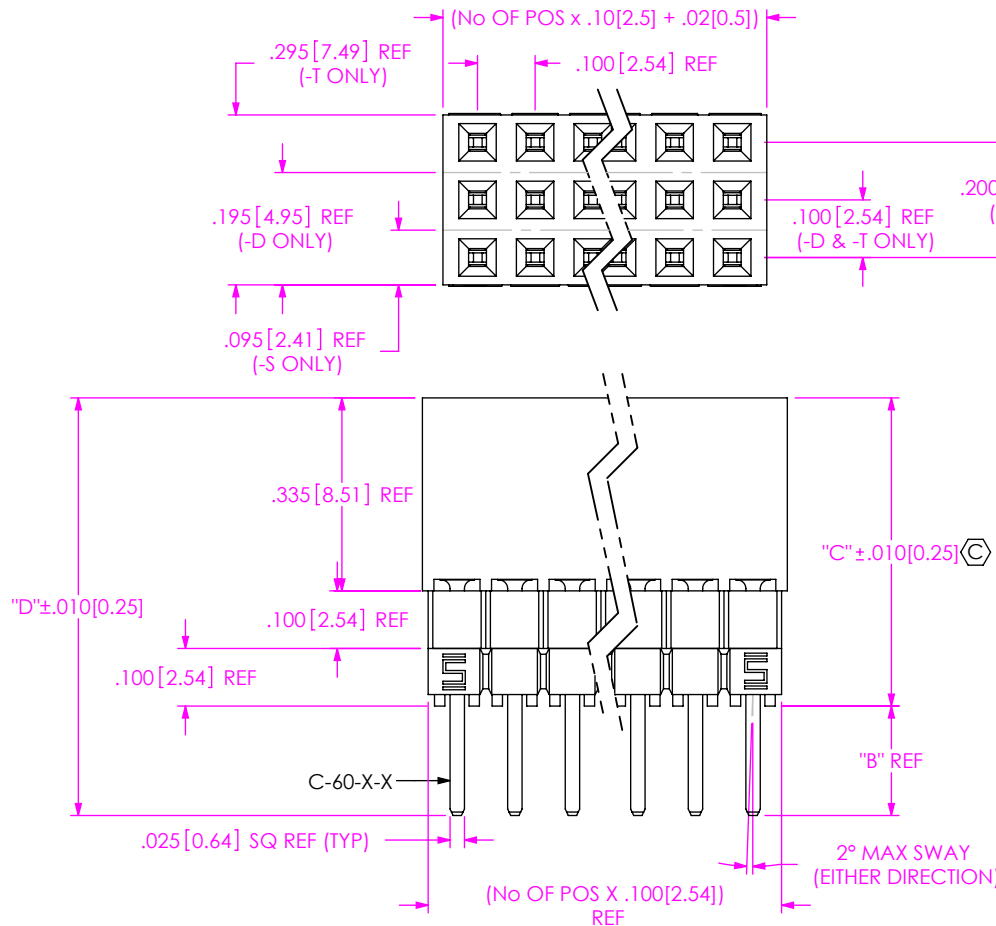

FIG 1
 ESQ-110-XX-X-T

UNLESS OTHERWISE SPECIFIED,
 DIMENSIONS ARE IN INCHES.
 TOLERANCES ARE:
 DECIMALS ANGLES
 .XX: ±.01 [0.3] 2°
 .XXX: ±.005 [0.13]
 .XXXX: ±.0020 [0.051]

PROPRIETARY NOTE
 THIS DOCUMENT CONTAINS CONFIDENTIAL AND PROPRIETARY INFORMATION AND ALL DESIGN, MANUFACTURING, REPRODUCTION, USE, PATENT RIGHTS AND SALES RIGHTS ARE EXPRESSLY RESERVED BY SAMTEC, INC. THIS DOCUMENT SHALL NOT BE DISCLOSED, IN WHOLE OR PART, TO ANY UNAUTHORIZED PERSON OR ENTITY NOR REPRODUCED, TRANSFERRED OR INCORPORATED IN ANY OTHER PROJECT IN ANY MANNER WITHOUT THE EXPRESS WRITTEN CONSENT OF SAMTEC, INC.

MATERIAL: DO NOT SCALE DRAWING SHEET SCALE: 3:1
 INSULATOR: LCP, UL 94 V0
 COLOR: BLACK
 CONTACT : PHOS BRONZE

samtec	
520 PARK EAST BLVD, NEW ALBANY, IN 47150 PHONE: 812-944-6733 FAX: 812-948-5047 e-Mail: info@SAMTEC.com code 53322	
DESCRIPTION:	ESQ STRIP ASM
DWG. NO.	ESQ-1XX-XX-X-X-XXX-XX-X-XX
BY: JORDAN	7-16-85 SHEET 1 OF 4

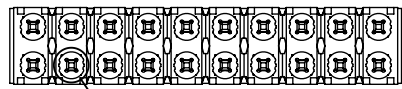

ESQ-110-XX-X-D-MW-T
 .005 [0.13] MAX MEASURE AT THE TAIL

DETAIL A
 SCALE 4 : 1

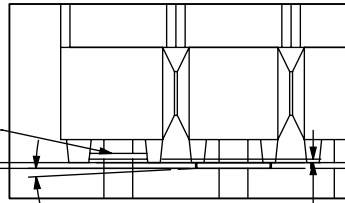

3° MAX SWAY ANY DIRECTION
 .003 [0.08] MAX MEASURE AT THE TAIL

DETAIL B
 SCALE 6 : 1

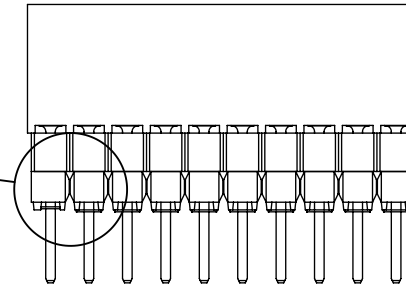

FIG 3
 #-H-MW: METAL WASHER
 ESQ-110-XX-X-MWT
 (ONE PER POSITION)
 (-S & -D BODY SPECS ONLY)
 (SEE NOTE 5)
 (SAME AS FIG 1 UNLESS OTHERWISE NOTED)

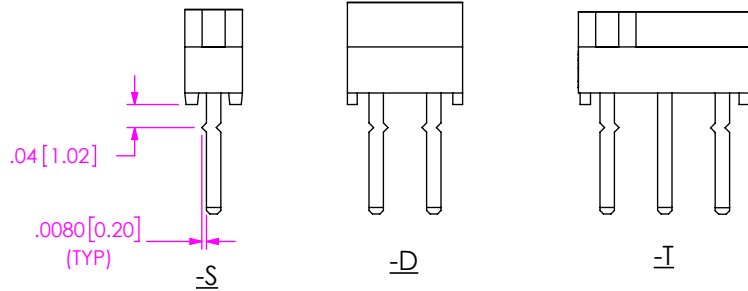
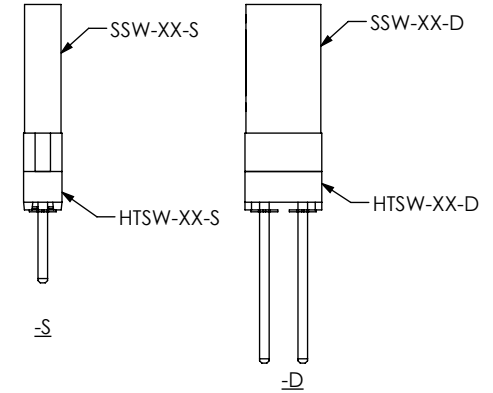

FIG 2
 -LL: LOCKING LEAD OPTION
 LOCATED ON OR ABOUT CENTERLINE
 [N/A IN 1 OR 2 POSITION SINGLE ROW]

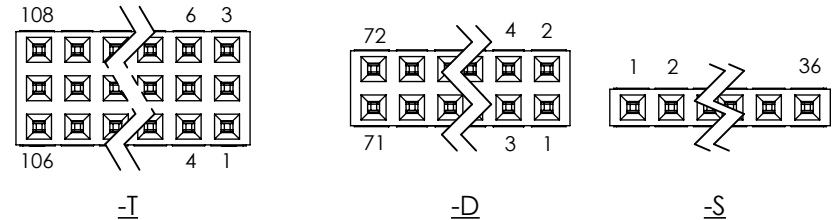

FIG 4
 XXX: POLARIZATION LOCATION
 INSERT PK-06-N INTO SPECIFIED POS
 AND BREAK OFF TAB

F:\DWG\MISC\MKTG\ESQ-1XX-XX-X-XXX-XX-X-MKT.SLDDRW

		TABLE 1 SPACER SPECIFICATION (FOR A ONE POSITION SINGLE SEE NOTE 3)			"B"	"C"	"D"	"E"
STANDARD INSERTION FORCE	CONTACT	ESQ-S	ESQ-D	ESQ-T				
		-12	C-15-2-X	N/A				
-13	C-15-3-X	N/A	N/A	N/A	.29[7.37]	.435[11.05]	.725[18.41]	N/A
-14	C-15-4-X	N/A	N/A	N/A	.48[12.2]	.435[11.05]	.915[23.24]	N/A
-23	C-15-3-X	(1) SUB-SSB-32	(1) DSB-XX	(1) SUB-SSB-32 (1) DSB-XX	.19[4.83]	.535[13.59]	.725[18.41]	N/A
-24	C-15-4-X	(1) SUB-SSB-32	(1) DSB-XX	(1) SUB-SSB-32 (1) DSB-XX	.38[9.65]	.535[13.59]	.915[23.24]	N/A
-33	C-15-3-X	(2) SUB-SSB-32	(2) DSB-XX	(2) SUB-SSB-32 (2) DSB-XX	.09[2.87]	.635[16.13]	.725[18.41]	N/A
-34	C-15-4-X	(2) SUB-SSB-32	(2) DSB-XX	(2) SUB-SSB-32 (2) DSB-XX	.28[7.11]	.635[16.13]	.915[23.24]	N/A
-44	C-15-4-X	(1) ESS-XX-S	(3) DSB-XX	(1) ESS-XX-S (3) DSB-XX	.18[4.57]	.735[18.67]	.915[23.24]	N/A
		SPACER SPECIFICATION (FOR A ONE POSITION SINGLE SEE NOTE 3)			"B"	"C"	"D"	"E"
LOW INSERTION FORCE	CONTACT	ESQ-S	ESQ-D	ESQ-T				
		-37	C-60-2-X	N/A				
-38	C-60-3-X	N/A	N/A	N/A	.29[7.37]	.435[11.05]	.725[18.41]	N/A
-39	C-60-4-X	N/A	N/A	N/A	.48[12.2]	.435[11.05]	.915[23.24]	N/A
-48	C-60-3-X	(1) SUB-SSB-32	(1) DSB-XX	(1) SUB-SSB-32 (1) DSB-XX	.19[4.83]	.535[13.59]	.725[18.41]	N/A
-49	C-60-4-X	(1) SUB-SSB-32	(1) DSB-XX	(1) SUB-SSB-32 (1) DSB-XX	.38[9.65]	.535[13.59]	.915[23.24]	N/A
-58	C-60-3-X	(2) SUB-SSB-32	(2) DSB-XX	(2) SUB-SSB-32 (2) DSB-XX	.09[2.87]	.635[16.13]	.725[18.41]	N/A
-59	C-60-4-X	(2) SUB-SSB-32	(2) DSB-XX	(2) SUB-SSB-32 (2) DSB-XX	.28[7.11]	.635[16.13]	.915[23.24]	N/A
-69	C-60-4-X	(1) ESS-XX-S	(3) DSB-XX	(1) ESS-XX-S (3) DSB-XX	.18[4.57]	.735[18.67]	.915[23.24]	N/A

PROPRIETARY NOTE
 THIS DOCUMENT CONTAINS CONFIDENTIAL AND PROPRIETARY INFORMATION AND ALL DESIGN, MANUFACTURING, REPRODUCTION, USE, PATENT RIGHTS AND SALES RIGHTS ARE EXPRESSLY RESERVED BY SAMTEC, INC. THIS DOCUMENT SHALL NOT BE DISCLOSED, IN WHOLE OR PART, TO ANY UNAUTHORIZED PERSON OR ENTITY NOR REPRODUCED, TRANSFERRED OR INCORPORATED IN ANY OTHER PROJECT IN ANY MANNER WITHOUT THE EXPRESS WRITTEN CONSENT OF SAMTEC, INC.

DO NOT SCALE DRAWING

SHEET SCALE: 1:1



520 PARK EAST BLVD, NEW ALBANY, IN 47150
 PHONE: 812-944-6733 FAX: 812-948-5047
 e-Mail: info@SAMTEC.com code 55322

DESCRIPTION: ESQ STRIP ASM
 DWG. NO. ESQ-1XX-XX-X-X-XXX-XX-X-XX
 BY: WHITTAKER 9-11-98 SHEET 2 OF 4

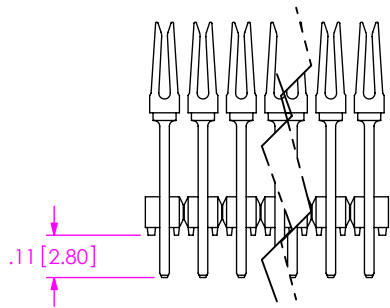

LOAD CONTACT

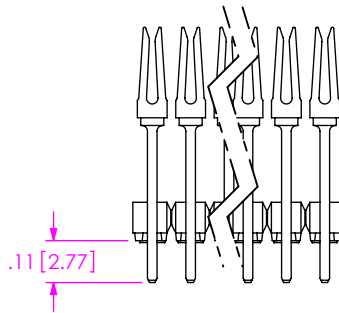

PRESS ON -MW

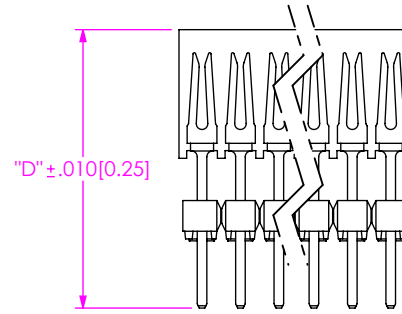

PRESS ON
SSW BODY

IN-PROCESS
-12, -33, -37, -58

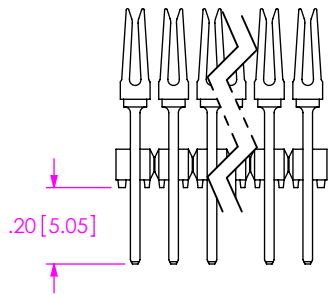

LOAD CONTACT

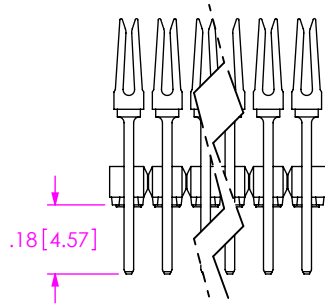

PRESS ON -MW

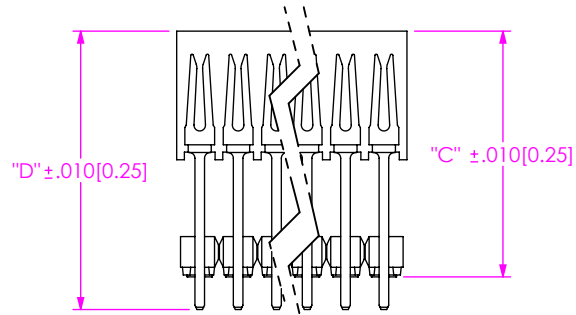

PRESS ON
SSW BODY

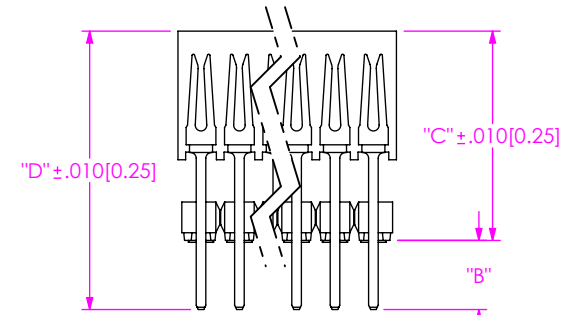

REPRESS STACKER BODY
AND -MW TO PROPER "C" DIM

IN-PROCESS
-13, -14, -23, -24, -34, -38
-39, -44, -48, -49, -59, -69

PROPRIETARY NOTE
THIS DOCUMENT CONTAINS CONFIDENTIAL AND PROPRIETARY INFORMATION AND ALL DESIGN, MANUFACTURING, REPRODUCTION, USE, PATENT RIGHTS AND SALES RIGHTS ARE EXPRESSLY RESERVED BY SAMTEC, INC. THIS DOCUMENT SHALL NOT BE DISCLOSED, IN WHOLE OR PART, TO ANY UNAUTHORIZED PERSON OR ENTITY NOR REPRODUCED, TRANSFERRED OR INCORPORATED IN ANY OTHER PROJECT IN ANY MANNER WITHOUT THE EXPRESS WRITTEN CONSENT OF SAMTEC, INC.

DO NOT SCALE DRAWING

SHEET SCALE: 1:1



520 PARK EAST BLVD, NEW ALBANY, IN 47150
PHONE: 812-944-6733 FAX: 812-948-5047
e-Mail info@SAMTEC.com code 55322

DESCRIPTION: ESQ STRIP ASM

DWG. NO. ESQ-1XX-XX-X-X-XXX-XX-X-XX

BY: WITHTAKER 9-11-98 SHEET 3 OF 4

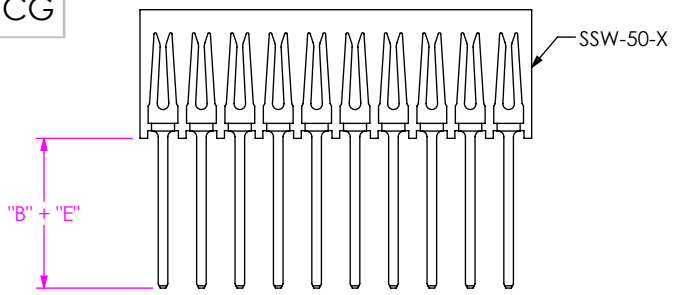

STEP 1
MACHINE FILL SSW-50-X

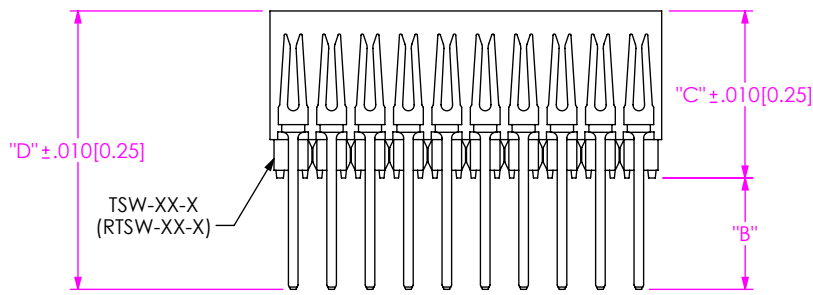

STEP 2
MULTI-CUT TSW-50-X TO POS (RTSW-50-D FOR DOUBLE ROW)
AND MOUNT AS SHOWN.
(IF RTSW-50-D NOT AVAILABLE, TSW-50-D MAY BE USED)

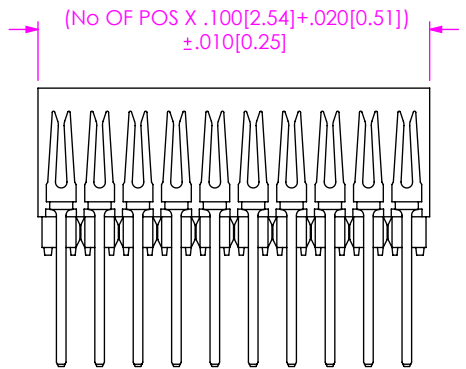

STEP 3
ROTO CUT TO POS

FIG 5
ESQ-110-XX-X-S
IN PROCESS "B"
(LEAD STYLE -12 & -37)
(-S & -D ONLY)

TABLE 2			
LEAD STYLE	ROW	TUBE	PLUG (2)
-12, -13, -14, -37, -38, -39	-S	PT-ESQ002	TP-03
-23, -24, -48, -49		PT-ESQ001	TP-03
-33, -34, -44, -58, -59, -69		PT-1-24-01-47	TP-24
-12, -37	-D	PT-1-24-03-44	TP-07
-14, -24, -34, -44, -39, -49, -59, -69		PT-1-24-02-47	TP-07
-13, -23, -33, -38, -48, -58		PT-1-24-01-51	TP-13
-12, -37	-T	PT-1-24-01-51	TP-13
-13, -14, -23, -24, -33, -34, -44, -38, -39, -48, -49, -58, -59, -69		PT-1-24-03-51	TP-13

1. FOR -12 & -37 LEAD STYLES TUBE PAC KAGE -04 THRU -36 POSITION ONLY.
2. FOR -13, -23, -33, -38, -48, & -58 LEAD STYLES TUBE PACKAGE -08 THRU -36 POSITIONS ONLY.
3. FOR -14, -24, -34, -44, -39, -49, -59, & -69 LEAD STYLES -05 THRU -36 POSITIONS ONLY.

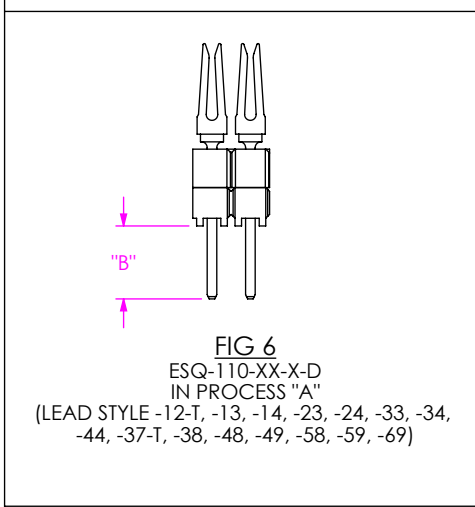
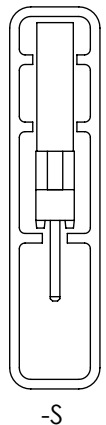
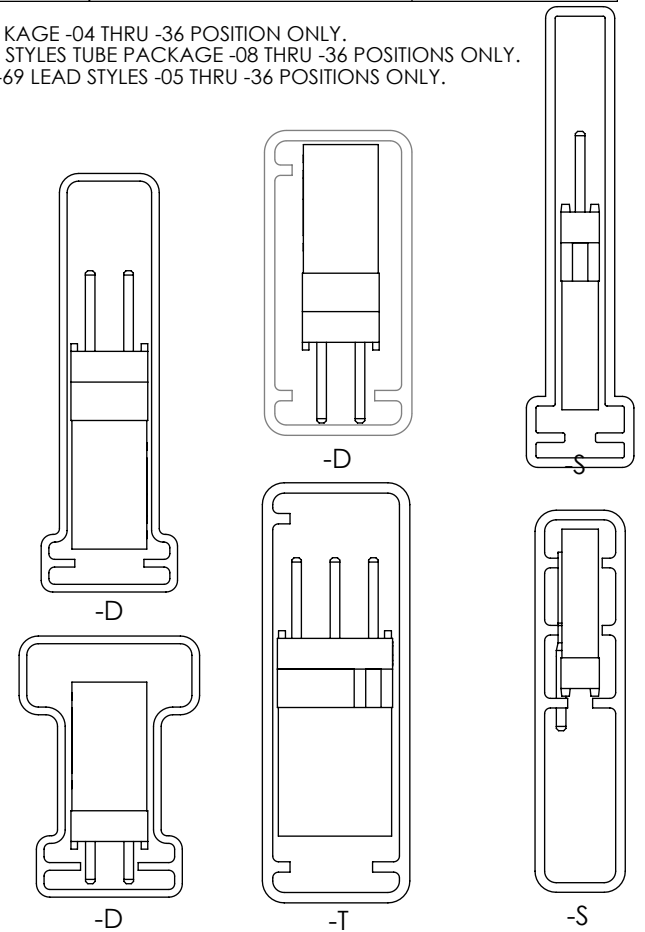

FIG 6
ESQ-110-XX-X-D
IN PROCESS "A"
(LEAD STYLE -12-T, -13, -14, -23, -24, -33, -34, -44, -37-T, -38, -48, -49, -58, -59, -69)



PROPRIETARY NOTE
THIS DOCUMENT CONTAINS CONFIDENTIAL AND PROPRIETARY INFORMATION AND ALL DESIGN, MANUFACTURING, REPRODUCTION, USE, PATENT RIGHTS AND SALES RIGHTS ARE EXPRESSLY RESERVED BY SAMTEC, INC. THIS DOCUMENT SHALL NOT BE DISCLOSED, IN WHOLE OR PART, TO ANY UNAUTHORIZED PERSON OR ENTITY NOR REPRODUCED, TRANSFERRED OR INCORPORATED IN ANY OTHER PROJECT IN ANY MANNER WITHOUT THE EXPRESS WRITTEN CONSENT OF SAMTEC, INC.

DO NOT SCALE DRAWING

SHEET SCALE: 1:1

samtec
520 PARK EAST BLVD, NEW ALBANY, IN 47150
PHONE: 812-944-6733 FAX: 812-948-5047
e-Mail info@SAMTEC.com code 55322

DESCRIPTION:	ESQ STRIP ASM
DWG. NO.	ESQ-1 XX-XX-X-X-XXX-XX-X-XX
BY: WHITTAKER 9-11-98	SHEET 4 OF 4