

DO NOT SCALE FROM THIS PRINT

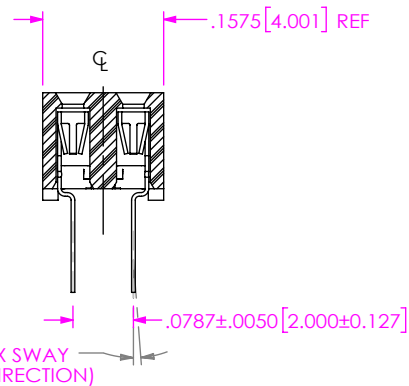
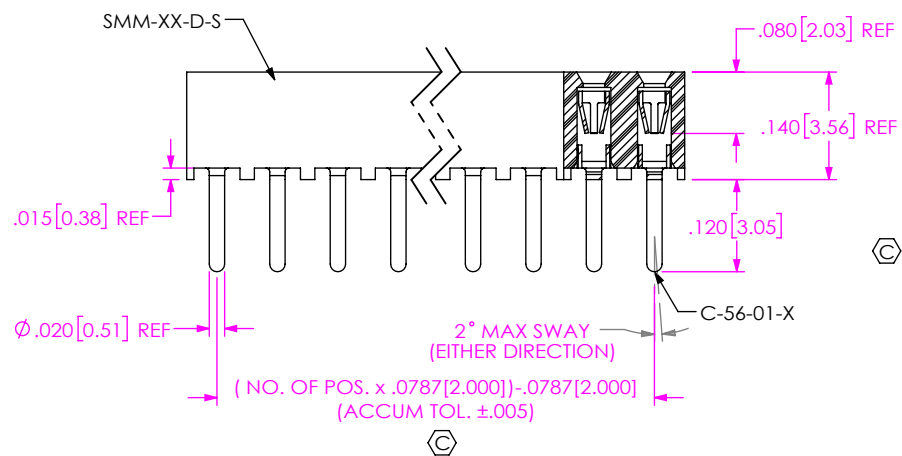
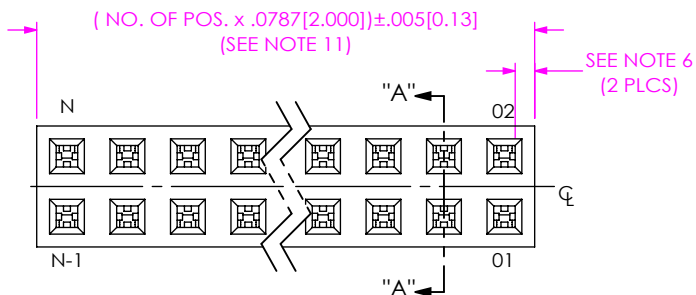
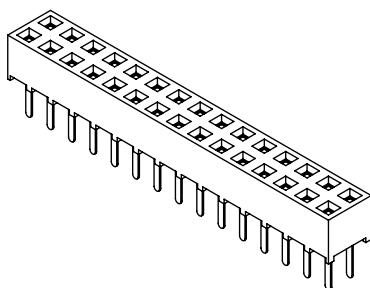

FIG 1
-01: THROUGH HOLE

SMM-1XX-XX-XX-D-XX-XX-X-XX

No OF POS PER ROW
THROUGH HOLE: -01 THRU -40
SURFACE MOUNT: -02 THUR -40

LEAD STYLE
-01: THROUGH HOLE (C-56-01-X)
-02: SURFACE MOUNT (C-56-02-X)

PLATING OPTION
-S: 30µ" SELECTIVE GOLD IN CONTACT AREA, MATTE TIN ON TAIL
-F: 3µ" FLASH SELECTIVE GOLD IN CONTACT AREA, MATTE TIN ON TAIL
-H: 30µ" HEAVY GOLD IN CONTACT AREA, 3µ" GOLD ON TAIL
-L: 10µ" LIGHT SELECTIVE GOLD IN CONTACT AREA, MATTE TIN ON TAIL
-SM: 30µ" SELECTIVE GOLD IN CONTACT AREA, MATTE TIN ON TAIL
-FM: 3µ" FLASH SELECTIVE GOLD IN CONTACT AREA, MATTE TIN ON TAIL

OPTION
-TR: TAPE & REEL
MAX. POSITIONS AVAILABLE:
27 VERTICAL / 28 HORIZONTAL
(SEE SHEET 3)

OPTION 2
-P: PICK & PLACE PAD (USE PPP-03, SEE FIG 3, SHT 2)
-K: POLYIMIDE FILM (USE K-DOT-217-.313-.005) (2 POS MIN, SEE FIG 4, SHT 2) (AVAILABLE ON LEAD STYLE -02 ONLY)

POLARIZING OPTION
INDICATE POSITION (USE PK-07-N)

OPTION 1
-LC: LOCKING CLIP (USE 2 LC-05-TM) (AVAILABLE ONLY WITH LEAD STYLE -02) (SEE NOTE 5 & 12)(SEE FIG 5, SHT 2)

ROW OPTION
-D: DOUBLE ROW (USE SMM-XX-D-S)

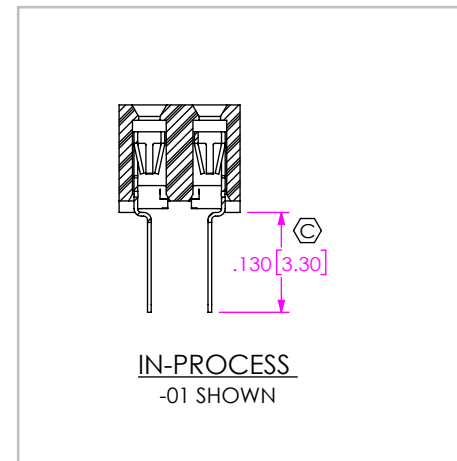

NOTES:

- ⊗ REPRESENTS A CRITICAL DIMENSION.
- RETENTION FORCE IN BODY TO BE: 1 lbs. MIN
- INSERTION FORCE TO BE: 3.0 oz. MAX.
- WITHDRAWAL FORCE TO BE: 0.5 oz. MIN.
- "-LC" OPTION FOR A 02 POSITION WILL HAVE ONLY ONE LOCKING CLIP (LC-05-TM).
- "END WALLS" AFTER CUTTING SHOULD BE .025±.005.
- FOR -01 LEAD STYLE, LAYER PACKAGE POSITIONS -01 THRU -04.
- FOR -02 LEAD STYLE WITHOUT PICK & PLACE PAD, LAYER PACKAGE POSITION -02 ONLY.
- 02 THRU -05 POSITION WITH -K OR -P TO BE PACKAGED IN -TR ONLY. -06 THUR -40 POSITION AVAILABLE IN TUBE OR -TR PACKAGING.
- MAXIMUM CUT FLASH: .010[.25].
- NO FLASH ALLOWED IN SOCKET OR EXTENDING BELOW LEADS.
- DUE TO THE HIGH AMOUNT OF INSERTION FORCE NEEDED, THE -LC OPTION IS NOT COMPATIBLE WITH AUTO PLACEMENT. SAMTEC RECOMMENDS MANUAL PLACMENT FOR ALL ASSEMBLIES WITH THE -LC OPTION.

UNLESS OTHERWISE SPECIFIED, DIMENSIONS ARE IN INCHES.
TOLERANCES ARE:
DECIMALS ANGLES
.XX: ±.01 [0.3] 2°
.XXX: ±.005 [0.13]
.XXXX: ±.0020 [0.051]

PROPRIETARY NOTE
THIS DOCUMENT CONTAINS CONFIDENTIAL AND PROPRIETARY INFORMATION AND ALL DESIGN, MANUFACTURING, REPRODUCTION, USE, PATENT RIGHTS AND SALES RIGHTS ARE EXPRESSLY RESERVED BY SAMTEC, INC. THIS DOCUMENT SHALL NOT BE DISCLOSED, IN WHOLE OR PART, TO ANY UNAUTHORIZED PERSON OR ENTITY NOR REPRODUCED, TRANSFERRED OR INCORPORATED IN ANY OTHER PROJECT IN ANY MANNER WITHOUT THE EXPRESS WRITTEN CONSENT OF SAMTEC, INC.

MATERIAL: DO NOT SCALE DRAWING SHEET SCALE: 4:1
INSULATOR: LCP UL 94V-O, COLOR: BLACK
CONTACT: BeCu

DESCRIPTION: 2 MM SOCKET STRIP
DWG. NO. SMM-1XX-XX-XX-D-XX-XX-X-XX
BY: JOE Z 04/20/2016 SHEET 1 OF 3



520 PARK EAST BLVD. NEW ALBANY, IN 47150
PHONE: 812-944-6733 FAX: 812-948-5047
e-Mail info@SAMTEC.com code 55322

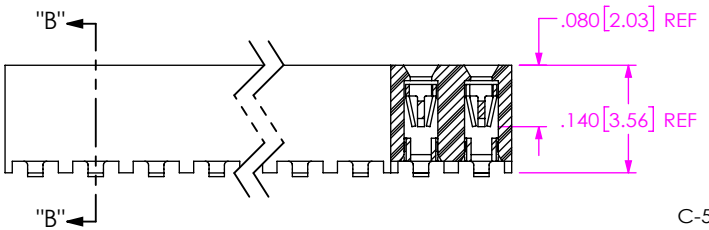
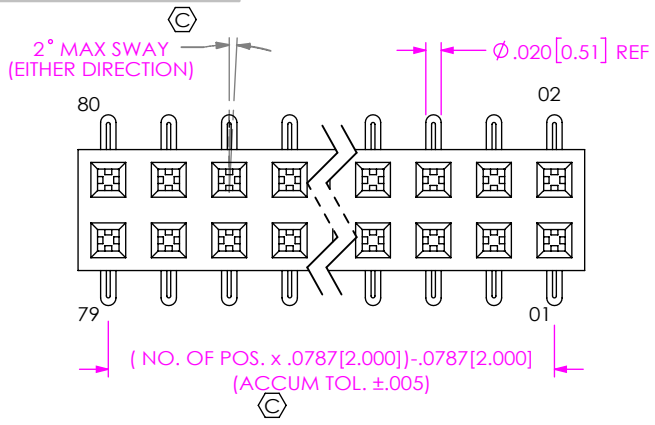
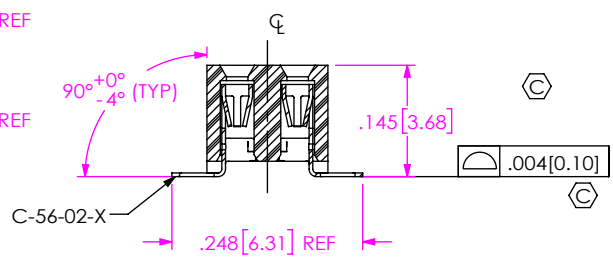
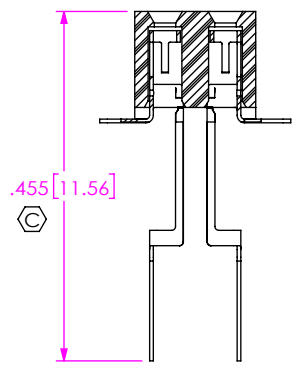

FIG 2
-02: SURFACE MOUNT
(SAME AS FIG 1, DIFFERENT AS SHOWN)



SECTION "B"-"B"



IN-PROCESS
-02 SHOWN

NOTE : "R"=NO OF POS x .0787 [2.000]
"S"={("R"-.394 [10.01])/2} ± .020 [0.51]

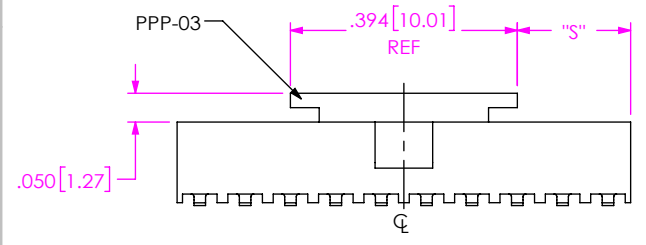
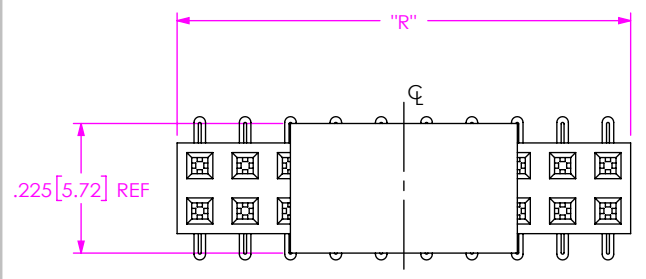

FIG 3
-P: PICK AND PLACE PAD
(PLACE PPP-03 ABOUT CL AS SHOWN)
(SAME AS FIG 1, DIFFERENT AS SHOWN)
(SEE NOTE 9)

NOTE : "R"=USED MEASURED DIMENSION (REF)
"S"={("R"-.2165 [5.50])/2} ± .020 [0.51]

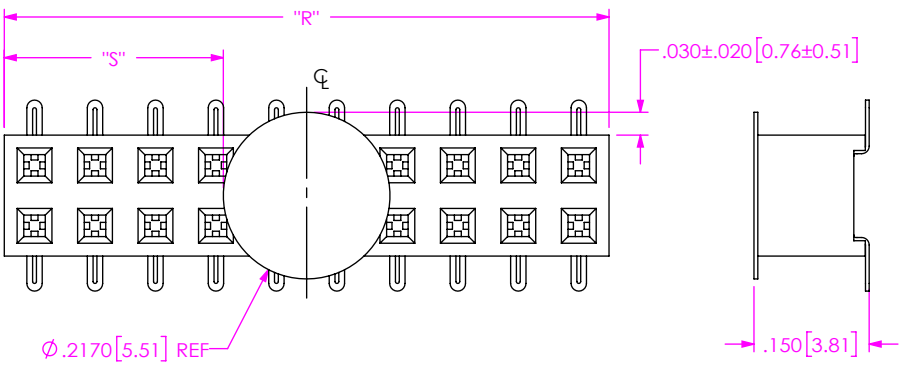

FIG 4
-K: POLYIMIDE FILM PAD
(2 POSITION MINIMUM, SEE NOTE 9)
(SAME AS FIG 1, DIFFERENT AS SHOWN)

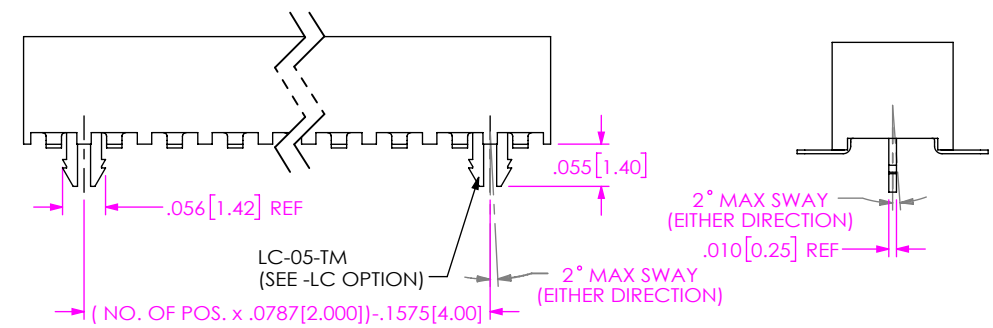
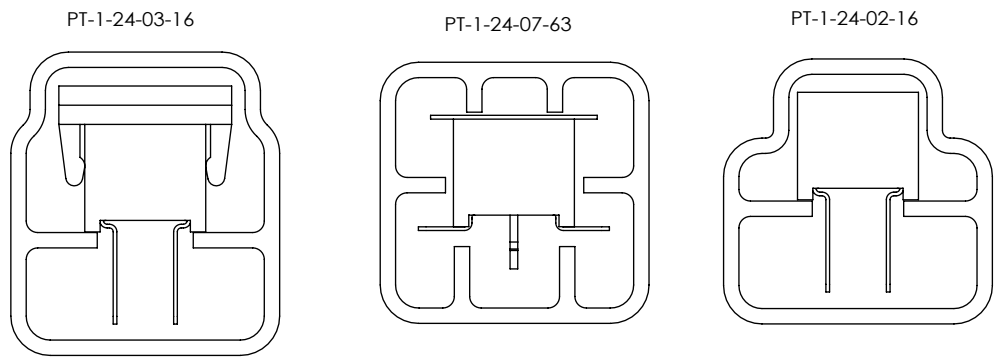
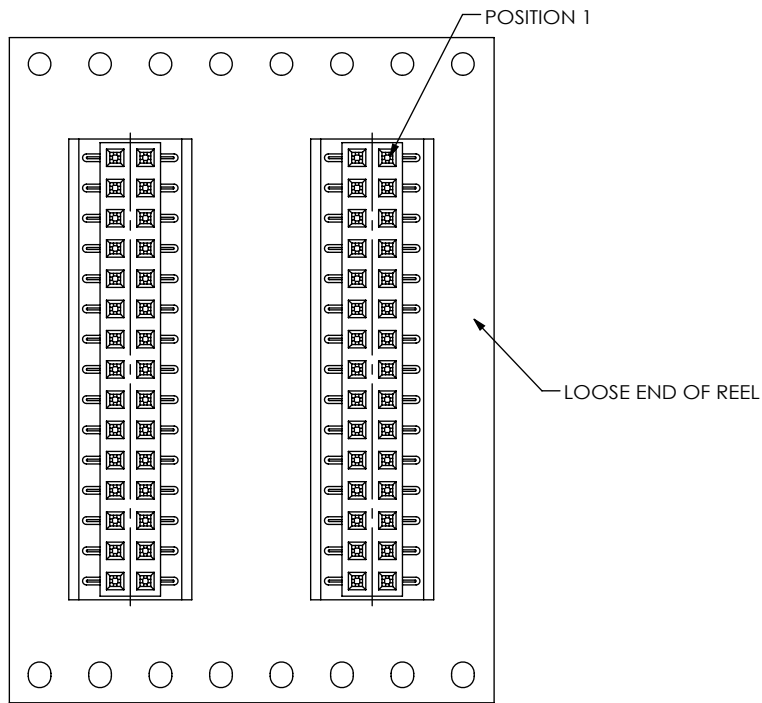

FIG 5
-LC: LOCKING CLIP
(SAME AS FIG 1, DIFFERENT AS SHOWN)

<p>PROPRIETARY NOTE</p> <p>THIS DOCUMENT CONTAINS CONFIDENTIAL AND PROPRIETARY INFORMATION AND ALL DESIGN, MANUFACTURING, REPRODUCTION, USE, PATENT RIGHTS AND SALES RIGHTS ARE EXPRESSLY RESERVED BY SAMTEC, INC. THIS DOCUMENT SHALL NOT BE DISCLOSED, IN WHOLE OR PART, TO ANY UNAUTHORIZED PERSON OR ENTITY NOR REPRODUCED, TRANSFERRED OR INCORPORATED IN ANY OTHER PROJECT IN ANY MANNER WITHOUT THE EXPRESS WRITTEN CONSENT OF SAMTEC, INC.</p>		
	<p>520 PARK EAST BLVD, NEW ALBANY, IN 47150 PHONE: 812-944-6733 FAX: 812-948-5047 e-Mail info@SAMTEC.com code 53322</p>	
	<p>SHEET SCALE: 4:1</p>	<p>DESCRIPTION: 2 MM SOCKET STRIP</p>
<p>BY: JOE Z</p>		<p>04/20/2016 SHEET 2 OF 3</p>

PACKAGE PARTS IN TUBES AS SHOWN



LEAD STYLE	OPTIONS	POS PER ROW	TUBE	PLUG
-01	NONE, -LC (SEE NOTE 7)	05 THRU 40	PT-1-24-02-16	TP-24
-02	NONE (SEE NOTE 8)	03 THRU 40	PT-1-24-02-16	TP-24
-02	-K, -K-LC	06 THRU 40	PT-1-24-07-63	TP-24
-01, -02	-P, -P-LC	06 THRU 40	PT-1-24-03-16	TP-03
-02	-LC	03 THRU 40	PT-1-24-07-63	TP-24

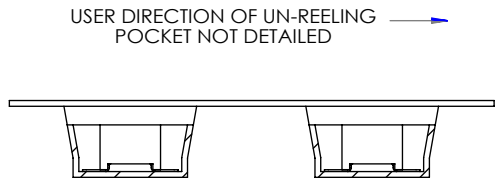

PACKAGING VIEW
-TR: TAPE AND REEL

<p>PROPRIETARY NOTE</p> <p>THIS DOCUMENT CONTAINS CONFIDENTIAL AND PROPRIETARY INFORMATION AND ALL DESIGN, MANUFACTURING, REPRODUCTION, USE, PATENT RIGHTS AND SALES RIGHTS ARE EXPRESSLY RESERVED BY SAMTEC, INC. THIS DOCUMENT SHALL NOT BE DISCLOSED, IN WHOLE OR PART, TO ANY UNAUTHORIZED PERSON OR ENTITY NOR REPRODUCED, TRANSFERRED OR INCORPORATED IN ANY OTHER PROJECT IN ANY MANNER WITHOUT THE EXPRESS WRITTEN CONSENT OF SAMTEC, INC.</p>	<p>520 PARK EAST BLVD, NEW ALBANY, IN 47150 PHONE: 812-944-6733 FAX: 812-948-5047 e-Mail: info@SAMTEC.com code 55322</p>	
	<p>SHEET SCALE: 4:1</p>	<p>DESCRIPTION: 2 MM SOCKET STRIP</p>
	<p>BY: JOE Z 04/20/2016 SHEET 3 OF 3</p>	<p>DWG. NO. SMM-1XX-XX-XX-D-XX-XX-X-XX</p>