

## LM56 Dual Output Low Power Thermostat

Check for Samples: [LM56](#)

### FEATURES

- Digital Outputs Support TTL Logic Levels
- Internal Temperature Sensor
- 2 Internal Comparators with Hysteresis
- Internal Voltage Reference
- Available in 8-pin SOIC and VSSOP Packages

### APPLICATIONS

- Microprocessor Thermal Management
- Appliances
- Portable Battery Powered 3.0V or 5V Systems
- Fan Control
- Industrial Process Control
- HVAC Systems
- Remote Temperature Sensing
- Electronic System Protection

### DESCRIPTION

The LM56 is a precision low power thermostat. Two stable temperature trip points ( $V_{T1}$  and  $V_{T2}$ ) are generated by dividing down the LM56 1.250V bandgap voltage reference using 3 external resistors. The LM56 has two digital outputs. OUT1 goes LOW when the temperature exceeds T1 and goes HIGH when the the temperature goes below ( $T1 - T_{HYST}$ ). Similarly, OUT2 goes LOW when the temperature exceeds T2 and goes HIGH when the temperature goes below ( $T2 - T_{HYST}$ ).  $T_{HYST}$  is an internally set 5°C typical hysteresis.

The LM56 is available in an 8-lead VSSOP surface mount package and an 8-lead SOIC.

**Table 1. Key Specifications**

	VALUE	UNIT
Power Supply Voltage	2.7V–10	V
Power Supply Current	230	μA (max)
$V_{REF}$	1.250	V ±1% (max)
Hysteresis Temperature	5	°C
Internal Temperature Sensor Output Voltage	$(+6.20 \text{ mV}/^{\circ}\text{C} \times T) + 395 \text{ mV}$	mV

**Table 2. Temperature Trip Point Accuracy**

	LM56BIM	LM56CIM
+25°C	±2°C (max)	±3°C (max)
+25°C to +85°C	±2°C (max)	±3°C (max)
–40°C to +125°C	±3°C (max)	±4°C (max)



Please be aware that an important notice concerning availability, standard warranty, and use in critical applications of Texas Instruments semiconductor products and disclaimers thereto appears at the end of this data sheet.

All trademarks are the property of their respective owners.

## Simplified Block Diagram and Connection Diagram

### Block Diagram

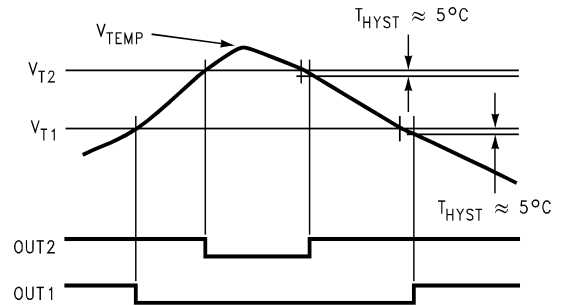
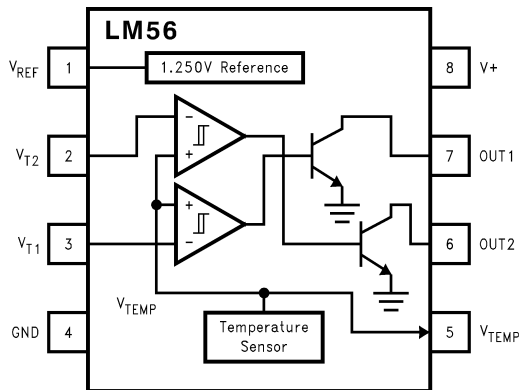

### Typical Application

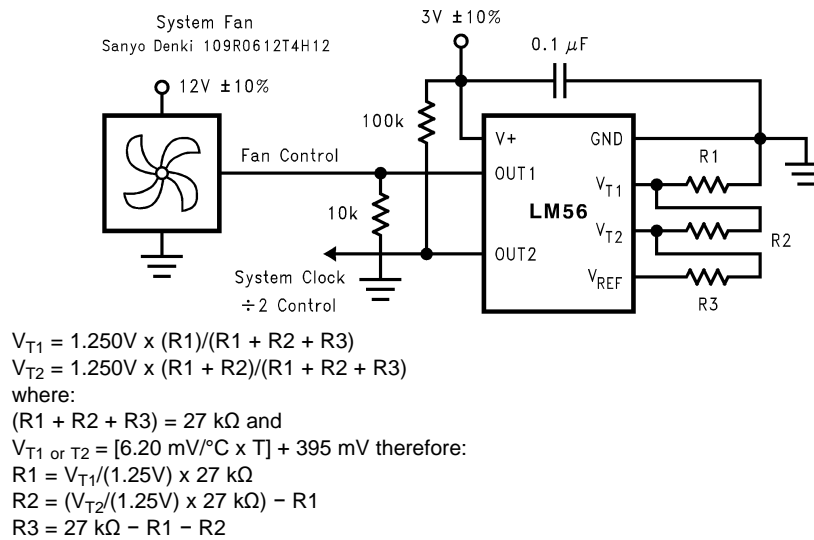

Figure 1. Microprocessor Thermal Management



These devices have limited built-in ESD protection. The leads should be shorted together or the device placed in conductive foam during storage or handling to prevent electrostatic damage to the MOS gates.

### Absolute Maximum Ratings<sup>(1)</sup>

Input Voltage		12V
Input Current at any pin <sup>(2)</sup>		5 mA
Package Input Current <sup>(2)</sup>		20 mA
Package Dissipation at T <sub>A</sub> = 25°C <sup>(3)</sup>		900 mW
ESD Susceptibility <sup>(4)</sup>	Human Body Model - Pin 3 Only	800V
	All other pins	1000V
	Machine Model	125V
	Storage Temperature	-65°C to + 150°C

- (1) Absolute Maximum Ratings indicate limits beyond which damage to the device may occur. Operating Ratings indicate conditions for which the device is functional, but do not guarantee specific performance limits. For guaranteed specifications and test conditions, see the [LM56 Electrical Characteristics](#). The guaranteed specifications apply only for the test conditions listed. Some performance characteristics may degrade when the device is not operated under the listed test conditions.
- (2) When the input voltage (V<sub>I</sub>) at any pin exceeds the power supply (V<sub>I</sub> < GND or V<sub>I</sub> > V<sup>+</sup>), the current at that pin should be limited to 5 mA. The 20 mA maximum package input current rating limits the number of pins that can safely exceed the power supplies with an input current of 5 mA to four.
- (3) The maximum power dissipation must be derated at elevated temperatures and is dictated by T<sub>Jmax</sub> (maximum junction temperature), θ<sub>JA</sub> (junction to ambient thermal resistance) and T<sub>A</sub> (ambient temperature). The maximum allowable power dissipation at any temperature is P<sub>D</sub> = (T<sub>Jmax</sub> - T<sub>A</sub>) / θ<sub>JA</sub> or the number given in the Absolute Maximum Ratings, whichever is lower. For this device, T<sub>Jmax</sub> = 125°C. For this device the typical thermal resistance (θ<sub>JA</sub>) of the different package types when board mounted follow:
- (4) The human body model is a 100 pF capacitor discharge through a 1.5 kΩ resistor into each pin. The machine model is a 200 pF capacitor discharged directly into each pin.

### Operating Ratings<sup>(1)(2)(3)</sup>

Operating Temperature Range	<b>T<sub>MIN</sub> ≤ T<sub>A</sub> ≤ T<sub>MAX</sub></b>
LM56BIM, LM56CIM	-40°C ≤ T <sub>A</sub> ≤ +125°C
Positive Supply Voltage (V <sup>+</sup> )	+2.7V to +10V
Maximum V <sub>OUT1</sub> and V <sub>OUT2</sub>	+10V

- (1) Absolute Maximum Ratings indicate limits beyond which damage to the device may occur. Operating Ratings indicate conditions for which the device is functional, but do not guarantee specific performance limits. For guaranteed specifications and test conditions, see the [LM56 Electrical Characteristics](#). The guaranteed specifications apply only for the test conditions listed. Some performance characteristics may degrade when the device is not operated under the listed test conditions.
- (2) Soldering process must comply with Reflow Temperature Profile specifications. Refer to <http://www.ti.com/packaging>.
- (3) Reflow temperature profiles are different for lead-free and non-lead-free packages.

Package Type	θ <sub>JA</sub>
D0008A	110°C/W
DGK0008A	250°C/W

## LM56 Electrical Characteristics

The following specifications apply for  $V^+ = 2.7 V_{DC}$ , and  $V_{REF}$  load current = 50  $\mu A$  unless otherwise specified. **Boldface limits apply for  $T_A = T_J = T_{MIN}$  to  $T_{MAX}$** ; all other limits  $T_A = T_J = 25^\circ C$  unless otherwise specified.

Symbol	Parameter	Conditions	Typical <sup>(1)</sup>	LM56BIM Limits <sup>(2)</sup>	LM56CIM Limits <sup>(2)</sup>	Units (Limits)
<b>Temperature Sensor</b>						
	Trip Point Accuracy (Includes $V_{REF}$ , Comparator Offset, and Temperature Sensitivity errors)	$+25^\circ C \leq T_A \leq +85^\circ C$		$\pm 2$	$\pm 3$	$^\circ C$ (max)
		$-40^\circ C \leq T_A \leq +125^\circ C$		$\pm 2$	$\pm 3$	$^\circ C$ (max)
				<b><math>\pm 3</math></b>	<b><math>\pm 4</math></b>	$^\circ C$ (max)
	Trip Point Hysteresis	$T_A = -40^\circ C$	4	3	3	$^\circ C$ (min)
				6	6	$^\circ C$ (max)
		$T_A = +25^\circ C$	5	3.5	3.5	$^\circ C$ (min)
					6.5	6.5
	$T_A = +85^\circ C$		6	4.5	4.5	$^\circ C$ (min)
					7.5	7.5
	$T_A = +125^\circ C$		6	4	4	$^\circ C$ (min)
					8	8
	Internal Temperature Sensitivity		+6.20			mV/ $^\circ C$
	Temperature Sensitivity Error			$\pm 2$	$\pm 3$	$^\circ C$ (max)
					<b><math>\pm 3</math></b>	<b><math>\pm 4</math></b>
	Output Impedance	$-1 \mu A \leq I_L \leq +40 \mu A$		<b>1500</b>	<b>1500</b>	$\Omega$ (max)
	Line Regulation	$+3.0V \leq V^+ \leq +10V$ , $+25^\circ C \leq T_A \leq +85^\circ C$		$-0.72/+0.3$ 6	$-0.72/+0.3$ 6	mV/V (max)
		$+3.0V \leq V^+ \leq +10V$ , $-40^\circ C \leq T_A < 25^\circ C$		$-1.14/+0.6$ 1	$-1.14/+0.6$ 1	mV/V (max)
		$+2.7V \leq V^+ \leq +3.3V$		<b><math>\pm 2.3</math></b>	<b><math>\pm 2.3</math></b>	mV (max)
<b><math>V_{T1}</math> and <math>V_{T2}</math> Analog Inputs</b>						
$I_{BIAS}$	Analog Input Bias Current		150	<b>300</b>	<b>300</b>	nA (max)
$V_{IN}$	Analog Input Voltage Range		$V^+ - 1$			V
			GND			V
$V_{OS}$	Comparator Offset		2	<b>8</b>	<b>8</b>	mV (max)
<b><math>V_{REF}</math> Output</b>						
$V_{REF}$	$V_{REF}$ Nominal		1.250V			V
	$V_{REF}$ Error			$\pm 1$	$\pm 1$	% (max)
				<b><math>\pm 12.5</math></b>	<b><math>\pm 12.5</math></b>	mV (max)
$\Delta V_{REF}/\Delta V^+$	Line Regulation	$+3.0V \leq V^+ \leq +10V$	0.13	<b>0.25</b>	<b>0.25</b>	mV/V (max)
		$+2.7V \leq V^+ \leq +3.3V$	0.15	<b>1.1</b>	<b>1.1</b>	mV (max)
$\Delta V_{REF}/\Delta I_L$	Load Regulation Sourcing	$+30 \mu A \leq I_L \leq +50 \mu A$		<b>0.15</b>	<b>0.15</b>	mV/ $\mu A$ (max)

(1) Typicals are at  $T_J = T_A = 25^\circ C$  and represent most likely parametric norm.

(2) Limits are guaranteed to TI's AOQL (Average Outgoing Quality Level).

Symbol	Parameter	Conditions	Typical <sup>(1)</sup>	Limits <sup>(2)</sup>	Units (Limits)
<b><math>V^+</math> Power Supply</b>					
$I_S$	Supply Current	$V^+ = +10V$		<b>230</b>	$\mu A$ (max)
		$V^+ = +2.7V$		<b>230</b>	$\mu A$ (max)
<b>Digital Outputs</b>					
$I_{OUT("1")}$	Logical "1" Output Leakage Current	$V^+ = +5.0V$		<b>1</b>	$\mu A$ (max)
$V_{OUT("0")}$	Logical "0" Output Voltage	$I_{OUT} = +50 \mu A$		<b>0.4</b>	V (max)

(1) Typicals are at  $T_J = T_A = 25^\circ C$  and represent most likely parametric norm.

(2) Limits are guaranteed to TI's AOQL (Average Outgoing Quality Level).

Typical Performance Characteristics

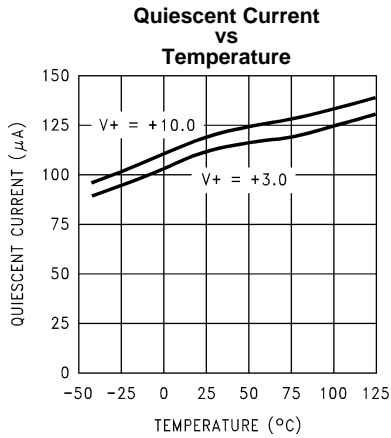

Figure 2.

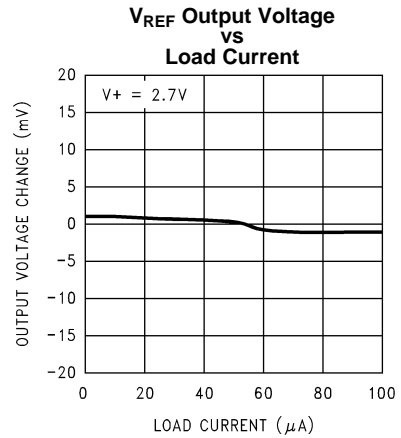

Figure 3.

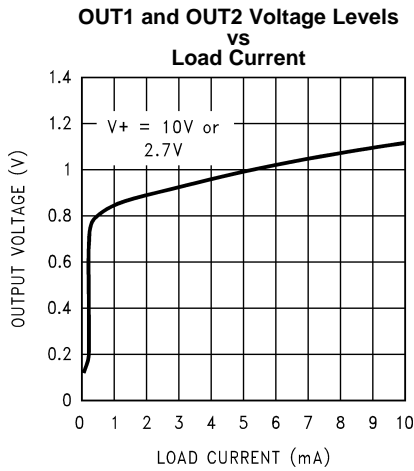

Figure 4.

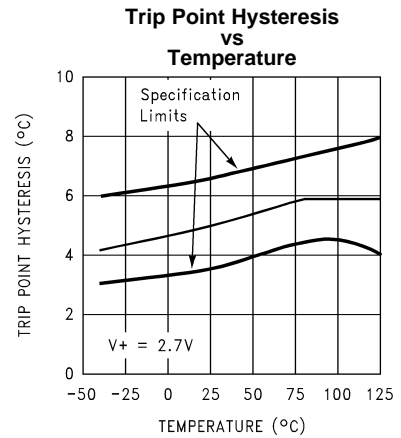

Figure 5.

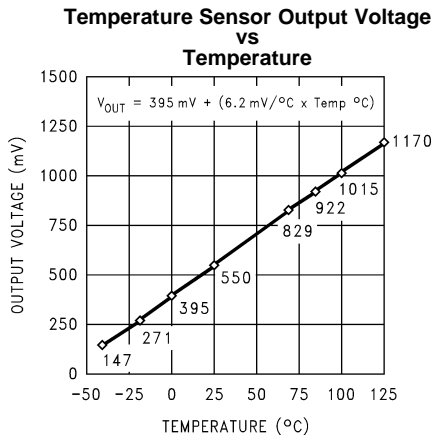

Figure 6.

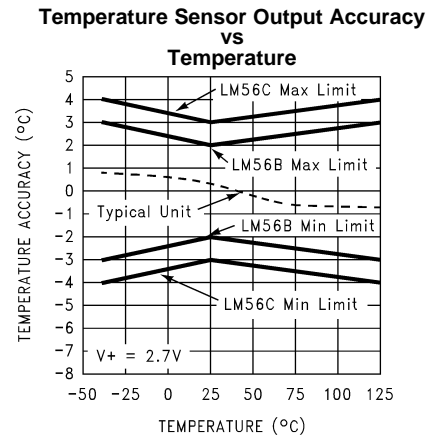

Figure 7.

**Typical Performance Characteristics (continued)**

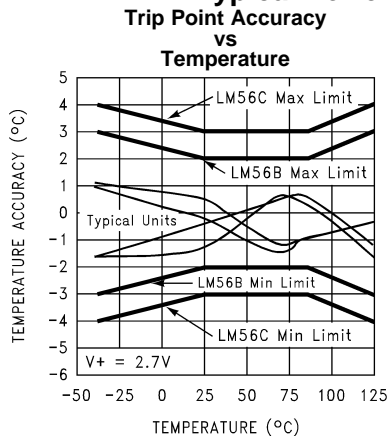

Figure 8.

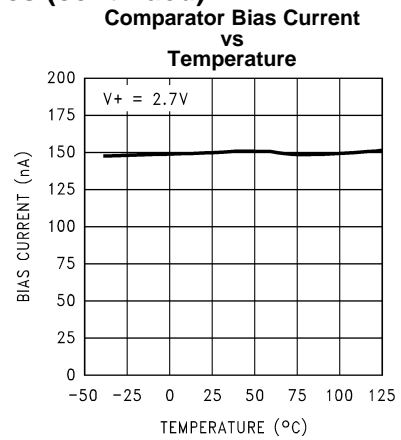

Figure 9.

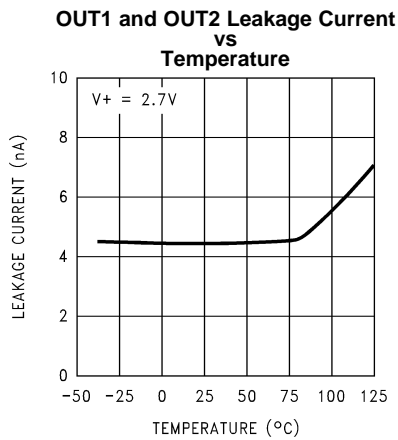

Figure 10.

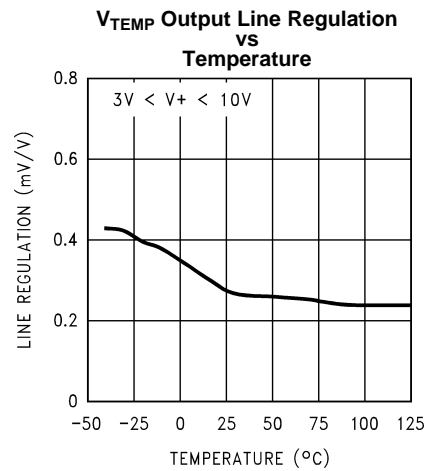

Figure 11.

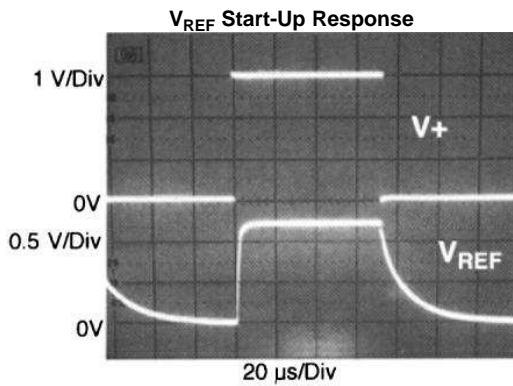

Figure 12.

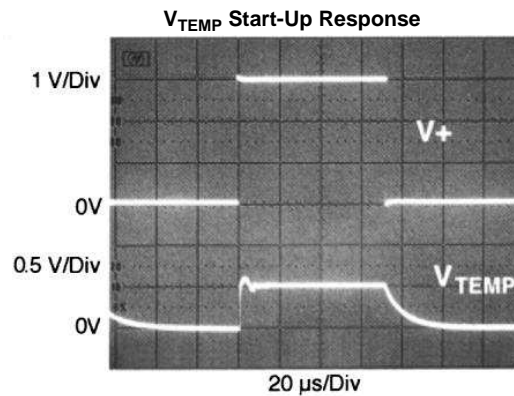
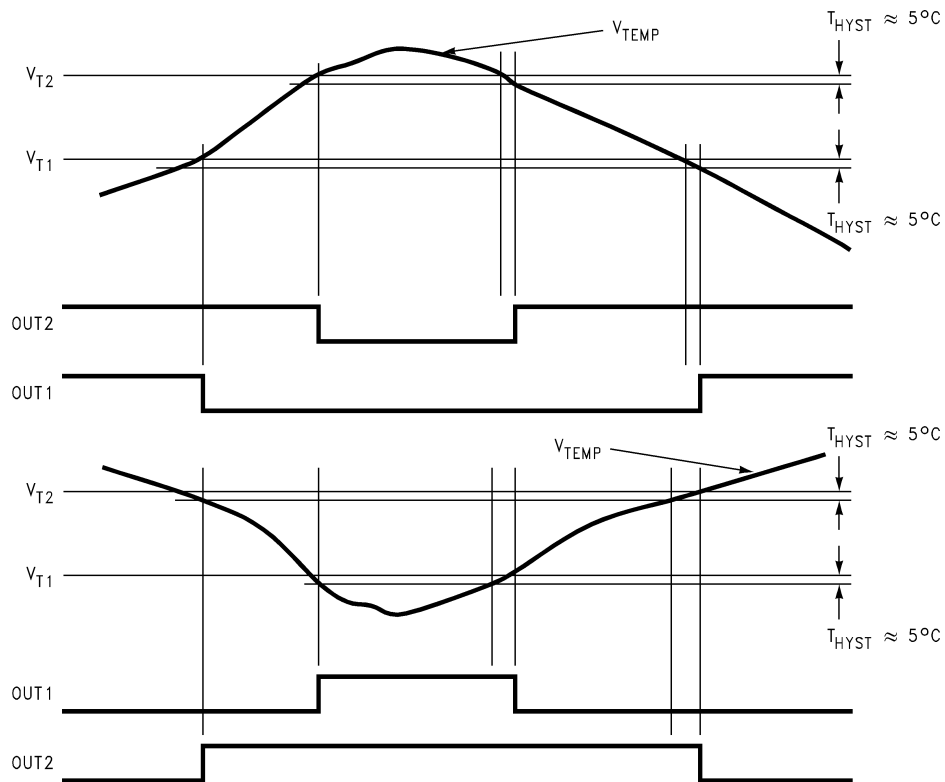

Figure 13.

FUNCTIONAL DESCRIPTION



Pin Functions

V <sup>+</sup>	This is the positive supply voltage pin. This pin should be bypassed with a 0.1 μF capacitor to ground.
GND	This is the ground pin.
V <sub>REF</sub>	This is the 1.250V bandgap voltage reference output pin. In order to maintain trip point accuracy this pin should source a 50 μA load.
V <sub>TEMP</sub>	This is the temperature sensor output pin.
OUT1	This is an open collector digital output. OUT1 is active LOW. It goes LOW when the temperature is greater than T <sub>1</sub> and goes HIGH when the temperature drops below T <sub>1</sub> – 5°C. This output is not intended to directly drive a fan motor.
OUT2	This is an open collector digital output. OUT2 is active LOW. It goes LOW when the temperature is greater than the T <sub>2</sub> set point and goes HIGH when the temperature is less than T <sub>2</sub> – 5°C. This output is not intended to directly drive a fan motor.
V <sub>T1</sub>	This is the input pin for the temperature trip point voltage for OUT1.
V <sub>T2</sub>	This is the input pin for the low temperature trip point voltage for OUT2.

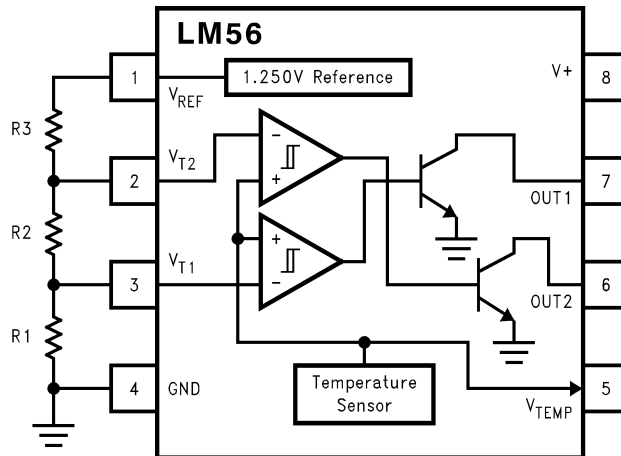

$$V_{T1} = 1.250V \times (R1)/(R1 + R2 + R3)$$

$$V_{T2} = 1.250V \times (R1 + R2)/(R1 + R2 + R3)$$

where:

$$(R1 + R2 + R3) = 27 \text{ k}\Omega \text{ and}$$

$$V_{T1 \text{ or } T2} = [6.20 \text{ mV}/^\circ\text{C} \times T] + 395 \text{ mV} \text{ therefore:}$$

$$R1 = V_{T1}/(1.25V) \times 27 \text{ k}\Omega$$

$$R2 = (V_{T2}/(1.25V) \times 27 \text{ k}\Omega) - R1$$

$$R3 = 27 \text{ k}\Omega - R1 - R2$$

**Application Hints**

**LM56 TRIP POINT ACCURACY SPECIFICATION**

For simplicity the following is an analysis of the trip point accuracy using the single output configuration shown in Figure 14 with a set point of 82°C.

Trip Point Error Voltage =  $V_{TPE}$ ,

Comparator Offset Error for  $V_{T1E}$

Temperature Sensor Error =  $V_{TSE}$

Reference Output Error =  $V_{RE}$

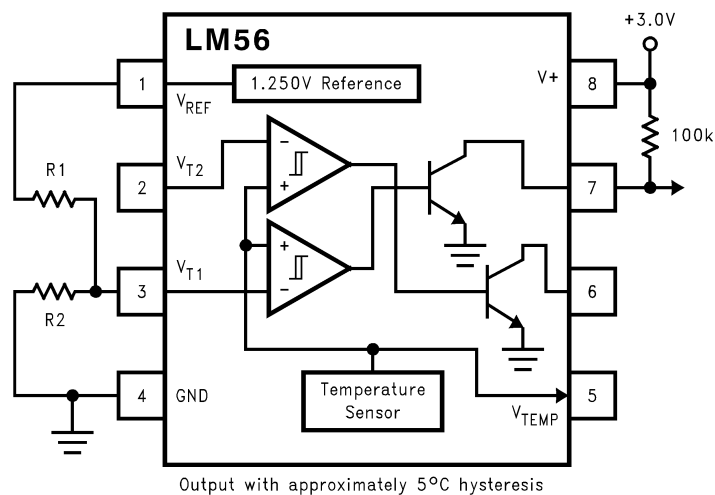

**Figure 14. Single Output Configuration**



$$1. V_{TPE} = \pm V_{T1E} - V_{TSE} + V_{RE}$$

Where:

$$2. V_{T1E} = \pm 8 \text{ mV (max)}$$

$$3. V_{TSE} = (6.20 \text{ mV/}^\circ\text{C}) \times (\pm 3^\circ\text{C}) = \pm 18.6 \text{ mV}$$

$$4. V_{RE} = 1.250\text{V} \times (\pm 0.01) R2/(R1 + R2)$$

Using Equations from [Figure 1](#).

$$V_{T1} = 1.25\text{V} \times R2/(R1 + R2) = 6.20 \text{ mV/}^\circ\text{C}(82^\circ\text{C}) + 395 \text{ mV}$$

$$\text{Solving for } R2/(R1 + R2) = 0.7227$$

then,

$$5. V_{RE} = 1.250\text{V} \times (\pm 0.01) R2/(R1 + R2) = (0.0125) \times (0.7227) = \pm 9.03 \text{ mV}$$

The individual errors do not add algebraically because, the odds of all the errors being at their extremes are rare. This is proven by the fact the specification for the trip point accuracy stated in the [LM56 Electrical Characteristics](#) for the temperature range of  $-40^\circ\text{C}$  to  $+125^\circ\text{C}$ , for example, is specified at  $\pm 3^\circ\text{C}$  for the LM56BIM. Note this trip point error specification does not include any error introduced by the tolerance of the actual resistors used, nor any error introduced by power supply variation.

If the resistors have a  $\pm 0.5\%$  tolerance, an additional error of  $\pm 0.4^\circ\text{C}$  will be introduced. This error will increase to  $\pm 0.8^\circ\text{C}$  when both external resistors have a  $\pm 1\%$  tolerance.

### BIAS CURRENT EFFECT ON TRIP POINT ACCURACY

Bias current for the comparator inputs is 300 nA (max) each, over the specified temperature range and will not introduce considerable error if the sum of the resistor values are kept to about 27 k $\Omega$  as shown in the typical application of [Figure 1](#). This bias current of one comparator input will not flow if the temperature is well below the trip point level. As the temperature approaches trip point level the bias current will start to flow into the resistor network. When the temperature sensor output is equal to the trip point level the bias current will be 150 nA (max). Once the temperature is well above the trip point level the bias current will be 300 nA (max). Therefore, the first trip point will be affected by 150 nA of bias current. The leakage current is very small when the comparator input transistor of the different pair is off (see [Figure 15](#)).

The effect of the bias current on the first trip point can be defined by the following equations:

$$K1 = \frac{R1}{R1 + R2 + R3}$$

$$V_{T1} = K1 \times V_{REF} + K1 \times (R2 + R3) \times \frac{I_B}{2} \quad (1)$$

where  $I_B = 300 \text{ nA}$  (the maximum specified error).

The effect of the bias current on the second trip point can be defined by the following equations:

$$K2 = \frac{R1 + R2}{R1 + R2 + R3}$$

$$V_{T2} = K2 \times V_{REF} + \left( K1 + \frac{K2}{2} \right) \times R3 \times I_B \quad (2)$$

where  $I_B = 300 \text{ nA}$  (the maximum specified error).

The closer the two trip points are to each other the more significant the error is. Worst case would be when  $V_{T1} = V_{T2} = V_{REF}/2$ .

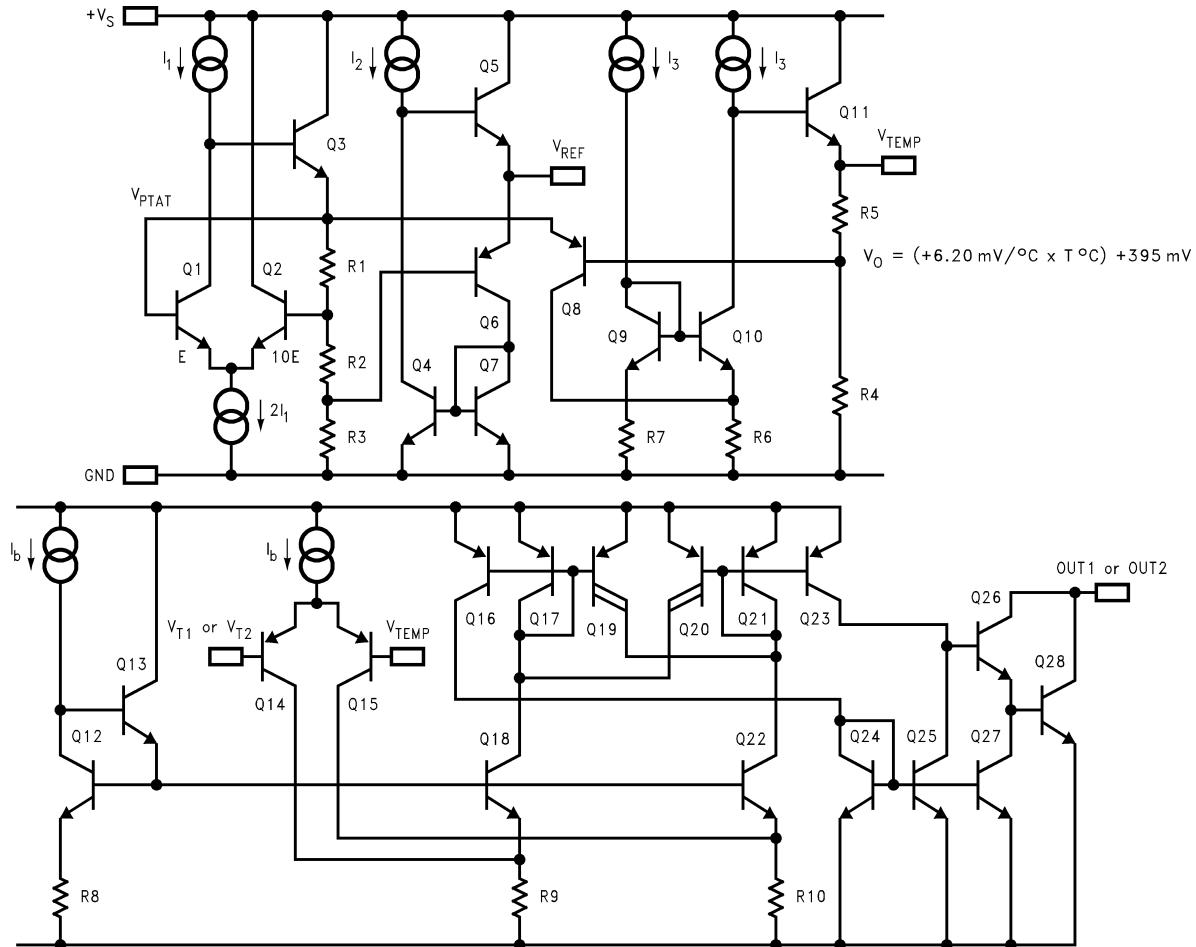

**Figure 15. Simplified Schematic**

## MOUNTING CONSIDERATIONS

The majority of the temperature that the LM56 is measuring is the temperature of its leads. Therefore, when the LM56 is placed on a printed circuit board, it is not sensing the temperature of the ambient air. It is actually sensing the temperature difference of the air and the lands and printed circuit board that the leads are attached to. The most accurate temperature sensing is obtained when the ambient temperature is equivalent to the LM56's lead temperature.

As with any IC, the LM56 and accompanying wiring and circuits must be kept insulated and dry, to avoid leakage and corrosion. This is especially true if the circuit operates at cold temperatures where condensation can occur. Printed-circuit coatings are often used to ensure that moisture cannot corrode the LM56 or its connections.

**V<sub>REF</sub> AND V<sub>TEMP</sub> CAPACITIVE LOADING**

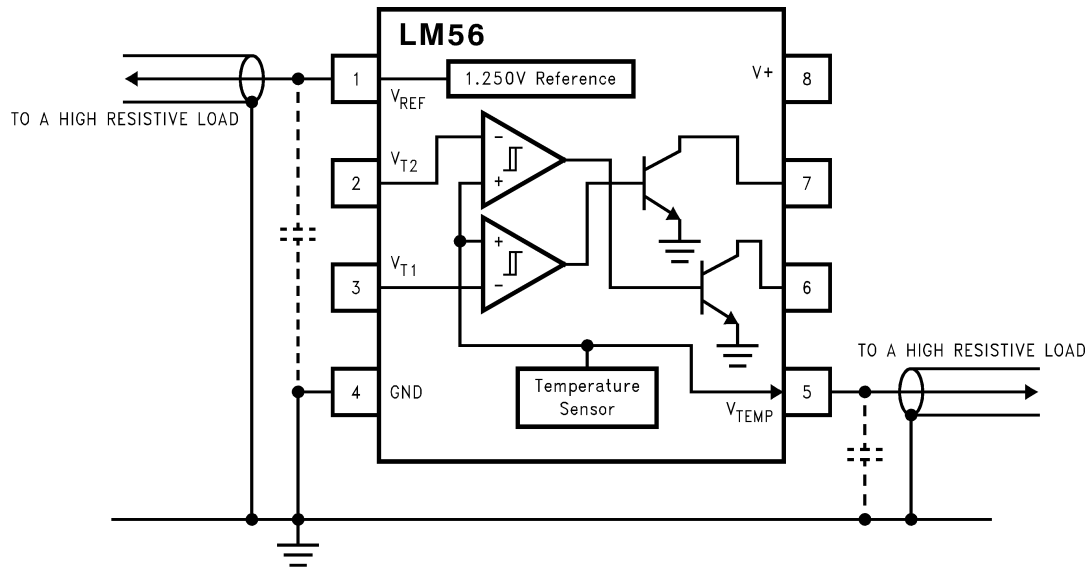

**Figure 16. Loading of V<sub>REF</sub> and V<sub>TEMP</sub>**

The LM56 V<sub>REF</sub> and V<sub>TEMP</sub> outputs handle capacitive loading well. Without any special precautions, these outputs can drive any capacitive load as shown in [Figure 16](#).

**NOISY ENVIRONMENTS**

Over the specified temperature range the LM56 V<sub>TEMP</sub> output has a maximum output impedance of 1500Ω. In an extremely noisy environment it may be necessary to add some filtering to minimize noise pickup. It is recommended that 0.1 μF be added from V<sup>+</sup> to GND to bypass the power supply voltage, as shown in [Figure 16](#). In a noisy environment it may be necessary to add a capacitor from the V<sub>TEMP</sub> output to ground. A 1 μF output capacitor with the 1500Ω output impedance will form a 106 Hz lowpass filter. Since the thermal time constant of the V<sub>TEMP</sub> output is much slower than the 9.4 ms time constant formed by the RC, the overall response time of the V<sub>TEMP</sub> output will not be significantly affected. For much larger capacitors this additional time lag will increase the overall response time of the LM56.

**APPLICATIONS CIRCUITS**

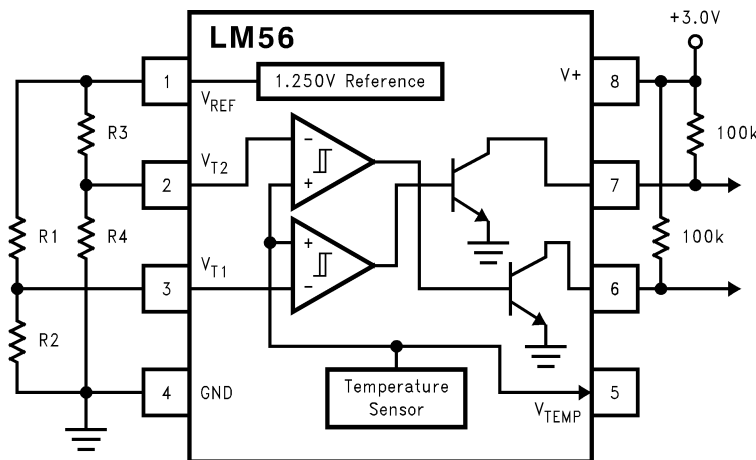

**Figure 17. Reducing Errors Caused by Bias Current**

The circuit shown in [Figure 17](#) will reduce the effective bias current error for  $V_{T2}$  as discussed in Section 3.0 to be equivalent to the error term of  $V_{T1}$ . For this circuit the effect of the bias current on the first trip point can be defined by the following equations:

$$K1 = \frac{R2}{R1 + R2}$$

$$V_{T1} = K1 \times V_{REF} + K1 \times (R1) \times \frac{I_B}{2} \quad (3)$$

where  $I_B = 300 \text{ nA}$  (the maximum specified error).

Similarly, bias current affect on  $V_{T2}$  can be defined by:

$$K2 = \frac{R4}{R3 + R4}$$

$$V_{T1} = K2 \times V_{REF} + K1 \times (R3) \times \frac{I_B}{2} \quad (4)$$

where  $I_B = 300 \text{ nA}$  (the maximum specified error).

The current shown in [Figure 18](#) is a simple overtemperature detector for power devices. In this example, an audio power amplifier IC is bolted to a heat sink and an LM56 Celsius temperature sensor is mounted on a PC board that is bolted to the heat sink near the power amplifier. To ensure that the sensing element is at the same temperature as the heat sink, the sensor's leads are mounted to pads that have feed throughs to the back side of the PC board. Since the LM56 is sensing the temperature of the actual PC board the back side of the PC board also has large ground plane to help conduct the heat to the device. The comparator's output goes low if the heat sink temperature rises above a threshold set by  $R1$ ,  $R2$ , and the voltage reference. This fault detection output from the comparator now can be used to turn on a cooling fan. The circuit as shown in design to turn the fan on when heat sink temperature exceeds about  $80^\circ\text{C}$ , and to turn the fan off when the heat sink temperature falls below approximately  $75^\circ\text{C}$ .

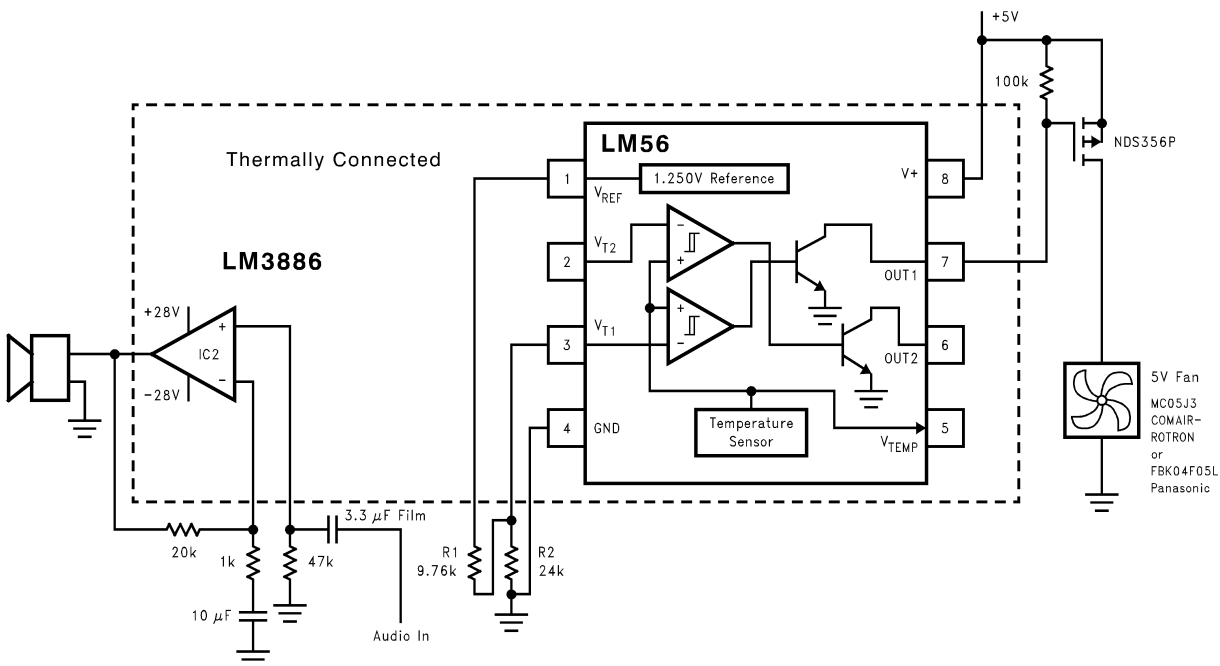

**Figure 18. Audio Power Amplifier Overtemperature Detector**

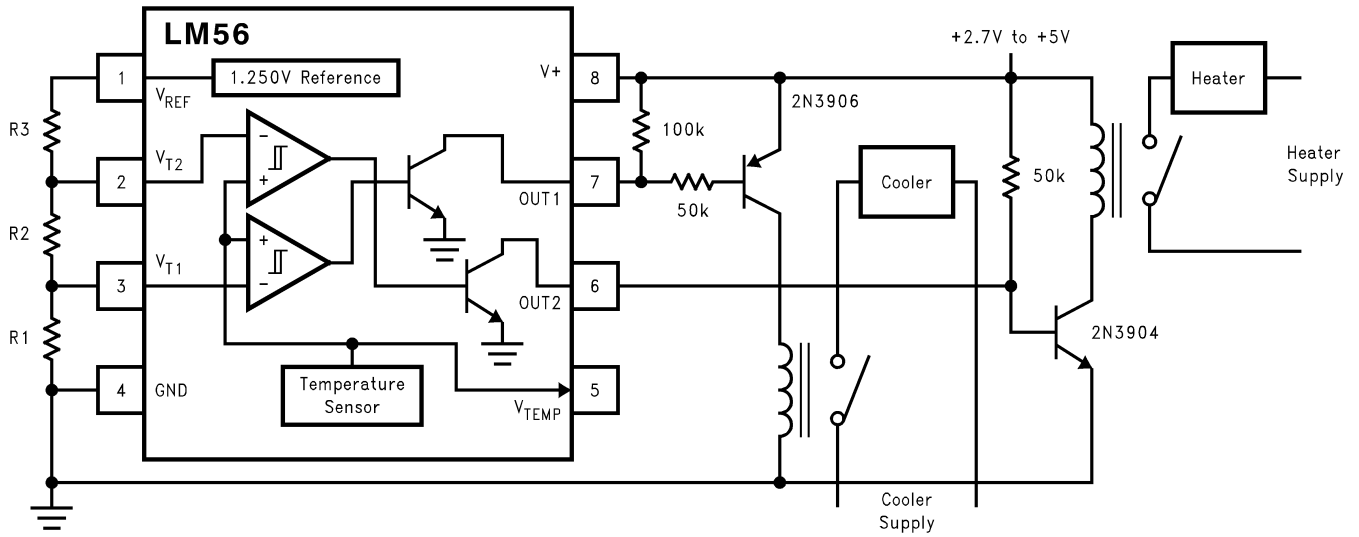

Figure 19. Simple Thermostat

### REVISION HISTORY

Changes from Revision F (February 2013) to Revision G	Page
• Changed layout of National Data Sheet to TI format .....	<a href="#">13</a>

**PACKAGING INFORMATION**

Orderable Device	Status (1)	Package Type	Package Drawing	Pins	Package Qty	Eco Plan (2)	Lead/Ball Finish (6)	MSL Peak Temp (3)	Op Temp (°C)	Device Marking (4/5)	Samples
LM56BIM	NRND	SOIC	D	8	95	TBD	Call TI	Call TI	-40 to 125	LM56 BIM	
LM56BIM/NOPB	ACTIVE	SOIC	D	8	95	Green (RoHS & no Sb/Br)	CU SN	Level-1-260C-UNLIM	-40 to 125	LM56 BIM	<a href="#">Samples</a>
LM56BIMM/NOPB	ACTIVE	VSSOP	DGK	8	1000	Green (RoHS & no Sb/Br)	CU SN	Level-1-260C-UNLIM	-40 to 125	T02B	<a href="#">Samples</a>
LM56BIMMX/NOPB	ACTIVE	VSSOP	DGK	8	3500	Green (RoHS & no Sb/Br)	CU SN	Level-1-260C-UNLIM	-40 to 125	T02B	<a href="#">Samples</a>
LM56BIMX/NOPB	ACTIVE	SOIC	D	8	2500	Green (RoHS & no Sb/Br)	CU SN	Level-1-260C-UNLIM	-40 to 125	LM56 BIM	<a href="#">Samples</a>
LM56CIM	NRND	SOIC	D	8	95	TBD	Call TI	Call TI	-40 to 125	LM56 CIM	
LM56CIM/NOPB	ACTIVE	SOIC	D	8	95	Green (RoHS & no Sb/Br)	CU SN	Level-1-260C-UNLIM	-40 to 125	LM56 CIM	<a href="#">Samples</a>
LM56CIMM/NOPB	ACTIVE	VSSOP	DGK	8	1000	Green (RoHS & no Sb/Br)	CU SN	Level-1-260C-UNLIM	-40 to 125	T02C	<a href="#">Samples</a>
LM56CIMMX/NOPB	ACTIVE	VSSOP	DGK	8	3500	Green (RoHS & no Sb/Br)	CU SN	Level-1-260C-UNLIM	-40 to 125	T02C	<a href="#">Samples</a>
LM56CIMX	NRND	SOIC	D	8	2500	TBD	Call TI	Call TI	-40 to 125	LM56 CIM	
LM56CIMX/NOPB	ACTIVE	SOIC	D	8	2500	Green (RoHS & no Sb/Br)	CU SN	Level-1-260C-UNLIM	-40 to 125	LM56 CIM	<a href="#">Samples</a>

(1) The marketing status values are defined as follows:

**ACTIVE:** Product device recommended for new designs.

**LIFEBUY:** TI has announced that the device will be discontinued, and a lifetime-buy period is in effect.

**NRND:** Not recommended for new designs. Device is in production to support existing customers, but TI does not recommend using this part in a new design.

**PREVIEW:** Device has been announced but is not in production. Samples may or may not be available.

**OBSOLETE:** TI has discontinued the production of the device.

(2) **RoHS:** TI defines "RoHS" to mean semiconductor products that are compliant with the current EU RoHS requirements for all 10 RoHS substances, including the requirement that RoHS substance do not exceed 0.1% by weight in homogeneous materials. Where designed to be soldered at high temperatures, "RoHS" products are suitable for use in specified lead-free processes. TI may reference these types of products as "Pb-Free".

**RoHS Exempt:** TI defines "RoHS Exempt" to mean products that contain lead but are compliant with EU RoHS pursuant to a specific EU RoHS exemption.

**Green:** TI defines "Green" to mean the content of Chlorine (Cl) and Bromine (Br) based flame retardants meet JS709B low halogen requirements of <=1000ppm threshold. Antimony trioxide based flame retardants must also meet the <=1000ppm threshold requirement.

- (3) MSL, Peak Temp. - The Moisture Sensitivity Level rating according to the JEDEC industry standard classifications, and peak solder temperature.
- (4) There may be additional marking, which relates to the logo, the lot trace code information, or the environmental category on the device.
- (5) Multiple Device Markings will be inside parentheses. Only one Device Marking contained in parentheses and separated by a "~" will appear on a device. If a line is indented then it is a continuation of the previous line and the two combined represent the entire Device Marking for that device.
- (6) Lead/Ball Finish - Orderable Devices may have multiple material finish options. Finish options are separated by a vertical ruled line. Lead/Ball Finish values may wrap to two lines if the finish value exceeds the maximum column width.

**Important Information and Disclaimer:**The information provided on this page represents TI's knowledge and belief as of the date that it is provided. TI bases its knowledge and belief on information provided by third parties, and makes no representation or warranty as to the accuracy of such information. Efforts are underway to better integrate information from third parties. TI has taken and continues to take reasonable steps to provide representative and accurate information but may not have conducted destructive testing or chemical analysis on incoming materials and chemicals. TI and TI suppliers consider certain information to be proprietary, and thus CAS numbers and other limited information may not be available for release.

In no event shall TI's liability arising out of such information exceed the total purchase price of the TI part(s) at issue in this document sold by TI to Customer on an annual basis.



**TAPE AND REEL INFORMATION**

**QUADRANT ASSIGNMENTS FOR PIN 1 ORIENTATION IN TAPE**

\*All dimensions are nominal

Device	Package Type	Package Drawing	Pins	SPQ	Reel Diameter (mm)	Reel Width W1 (mm)	A0 (mm)	B0 (mm)	K0 (mm)	P1 (mm)	W (mm)	Pin1 Quadrant
LM56BIMM/NOPB	VSSOP	DGK	8	1000	178.0	12.4	5.3	3.4	1.4	8.0	12.0	Q1
LM56BIMMX/NOPB	VSSOP	DGK	8	3500	330.0	12.4	5.3	3.4	1.4	8.0	12.0	Q1
LM56BIMX/NOPB	SOIC	D	8	2500	330.0	12.4	6.5	5.4	2.0	8.0	12.0	Q1
LM56CIMM/NOPB	VSSOP	DGK	8	1000	178.0	12.4	5.3	3.4	1.4	8.0	12.0	Q1
LM56CIMMX/NOPB	VSSOP	DGK	8	3500	330.0	12.4	5.3	3.4	1.4	8.0	12.0	Q1
LM56CIMX	SOIC	D	8	2500	330.0	12.4	6.5	5.4	2.0	8.0	12.0	Q1
LM56CIMX/NOPB	SOIC	D	8	2500	330.0	12.4	6.5	5.4	2.0	8.0	12.0	Q1

**TAPE AND REEL BOX DIMENSIONS**

\*All dimensions are nominal

Device	Package Type	Package Drawing	Pins	SPQ	Length (mm)	Width (mm)	Height (mm)
LM56BIMM/NOPB	VSSOP	DGK	8	1000	210.0	185.0	35.0
LM56BIMMX/NOPB	VSSOP	DGK	8	3500	367.0	367.0	35.0
LM56BIMX/NOPB	SOIC	D	8	2500	367.0	367.0	35.0
LM56CIMM/NOPB	VSSOP	DGK	8	1000	210.0	185.0	35.0
LM56CIMMX/NOPB	VSSOP	DGK	8	3500	367.0	367.0	35.0
LM56CIMX	SOIC	D	8	2500	367.0	367.0	35.0
LM56CIMX/NOPB	SOIC	D	8	2500	367.0	367.0	35.0

DGK (S-PDSO-G8)

PLASTIC SMALL-OUTLINE PACKAGE



- NOTES:
- A. All linear dimensions are in millimeters.
  - B. This drawing is subject to change without notice.
  - C. Body length does not include mold flash, protrusions, or gate burrs. Mold flash, protrusions, or gate burrs shall not exceed 0.15 per end.
  - D. Body width does not include interlead flash. Interlead flash shall not exceed 0.50 per side.
  - E. Falls within JEDEC MO-187 variation AA, except interlead flash.

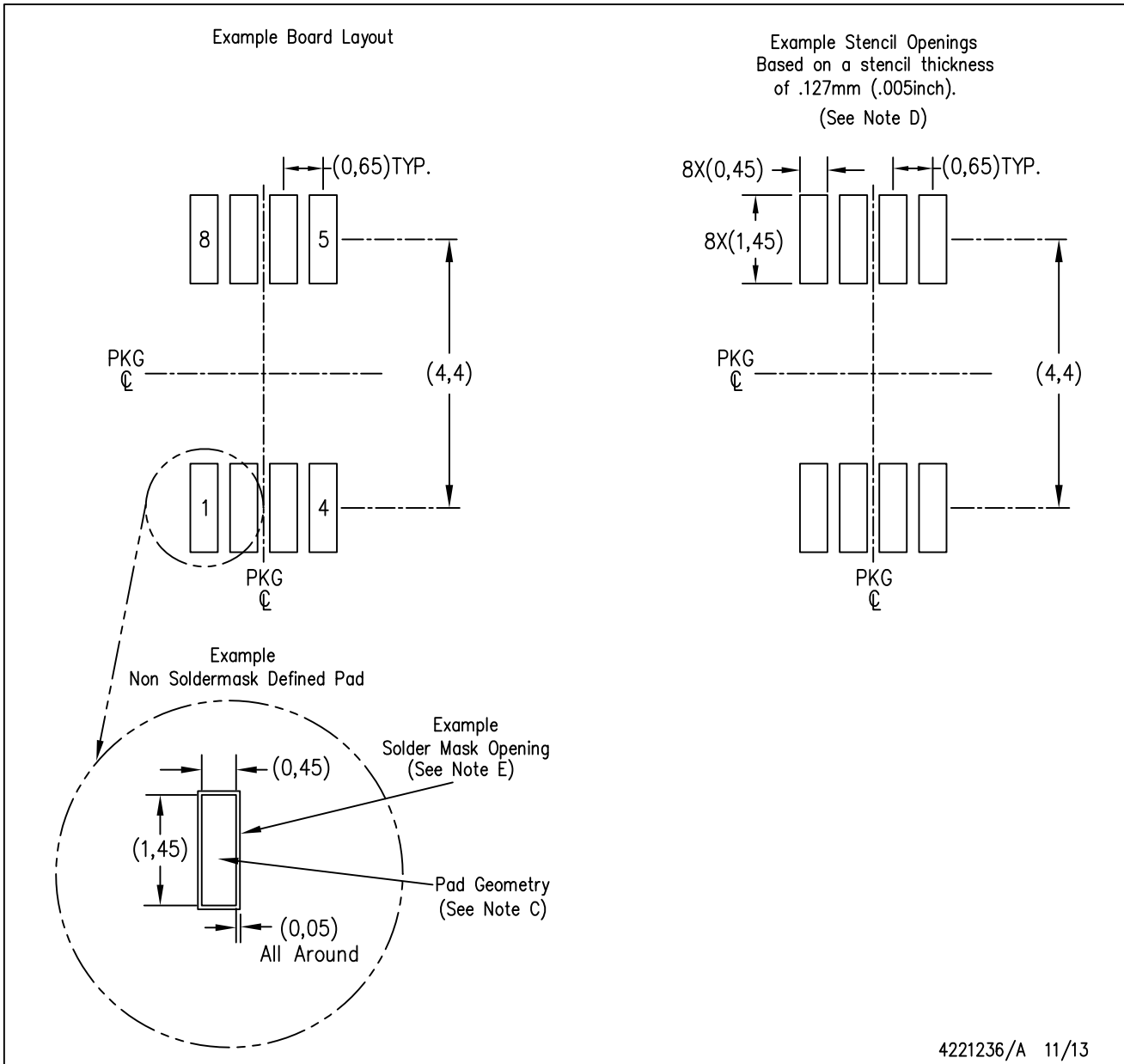

- NOTES:
- A. All linear dimensions are in millimeters.
  - B. This drawing is subject to change without notice.
  - C. Publication IPC-7351 is recommended for alternate designs.
  - D. Laser cutting apertures with trapezoidal walls and also rounding corners will offer better paste release. Customers should contact their board assembly site for stencil design recommendations. Refer to IPC-7525 for other stencil recommendations.
  - E. Customers should contact their board fabrication site for solder mask tolerances between and around signal pads.



D0008A

# PACKAGE OUTLINE

SOIC - 1.75 mm max height

SMALL OUTLINE INTEGRATED CIRCUIT



4214825/C 02/2019

NOTES:

- Linear dimensions are in inches [millimeters]. Dimensions in parenthesis are for reference only. Controlling dimensions are in inches. Dimensioning and tolerancing per ASME Y14.5M.
- This drawing is subject to change without notice.
- This dimension does not include mold flash, protrusions, or gate burrs. Mold flash, protrusions, or gate burrs shall not exceed  $.006$  [0.15] per side.
- This dimension does not include interlead flash.
- Reference JEDEC registration MS-012, variation AA.

# EXAMPLE BOARD LAYOUT

D0008A

SOIC - 1.75 mm max height

SMALL OUTLINE INTEGRATED CIRCUIT

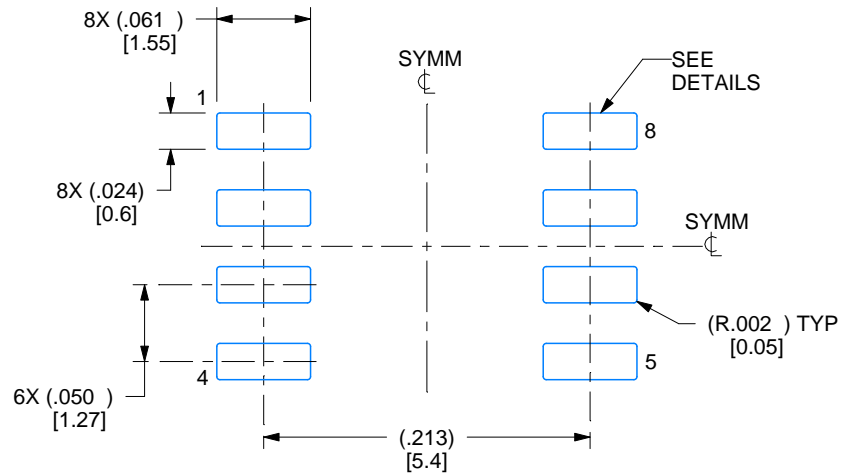

LAND PATTERN EXAMPLE  
EXPOSED METAL SHOWN  
SCALE:8X



SOLDER MASK DETAILS

4214825/C 02/2019

NOTES: (continued)

6. Publication IPC-7351 may have alternate designs.

7. Solder mask tolerances between and around signal pads can vary based on board fabrication site.

# EXAMPLE STENCIL DESIGN

D0008A

SOIC - 1.75 mm max height

SMALL OUTLINE INTEGRATED CIRCUIT



SOLDER PASTE EXAMPLE  
BASED ON .005 INCH [0.125 MM] THICK STENCIL  
SCALE:8X

4214825/C 02/2019

NOTES: (continued)

8. Laser cutting apertures with trapezoidal walls and rounded corners may offer better paste release. IPC-7525 may have alternate design recommendations.
9. Board assembly site may have different recommendations for stencil design.

## IMPORTANT NOTICE AND DISCLAIMER

TI PROVIDES TECHNICAL AND RELIABILITY DATA (INCLUDING DATASHEETS), DESIGN RESOURCES (INCLUDING REFERENCE DESIGNS), APPLICATION OR OTHER DESIGN ADVICE, WEB TOOLS, SAFETY INFORMATION, AND OTHER RESOURCES "AS IS" AND WITH ALL FAULTS, AND DISCLAIMS ALL WARRANTIES, EXPRESS AND IMPLIED, INCLUDING WITHOUT LIMITATION ANY IMPLIED WARRANTIES OF MERCHANTABILITY, FITNESS FOR A PARTICULAR PURPOSE OR NON-INFRINGEMENT OF THIRD PARTY INTELLECTUAL PROPERTY RIGHTS.

These resources are intended for skilled developers designing with TI products. You are solely responsible for (1) selecting the appropriate TI products for your application, (2) designing, validating and testing your application, and (3) ensuring your application meets applicable standards, and any other safety, security, or other requirements. These resources are subject to change without notice. TI grants you permission to use these resources only for development of an application that uses the TI products described in the resource. Other reproduction and display of these resources is prohibited. No license is granted to any other TI intellectual property right or to any third party intellectual property right. TI disclaims responsibility for, and you will fully indemnify TI and its representatives against, any claims, damages, costs, losses, and liabilities arising out of your use of these resources.

TI's products are provided subject to TI's Terms of Sale ([www.ti.com/legal/termsofsale.html](http://www.ti.com/legal/termsofsale.html)) or other applicable terms available either on [ti.com](http://ti.com) or provided in conjunction with such TI products. TI's provision of these resources does not expand or otherwise alter TI's applicable warranties or warranty disclaimers for TI products.

Mailing Address: Texas Instruments, Post Office Box 655303, Dallas, Texas 75265  
Copyright © 2019, Texas Instruments Incorporated