

# MALE PLUG M12 STRAIGHT

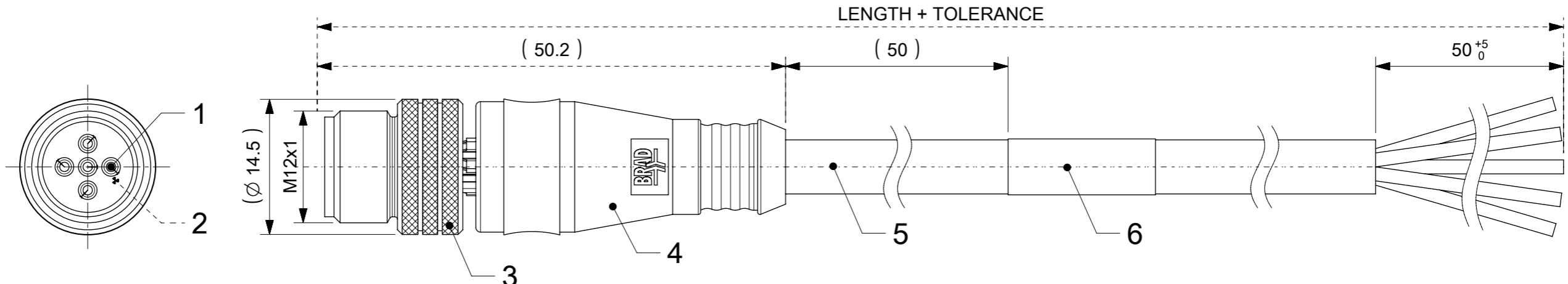

**NOTES:**  
 RATED VOLTAGE: 3, 4 contacts 250V  
 5 contacts 60V  
 8 contacts 30V  
 RATED CURRENT: 3, 4, 5 contacts 4A  
 8 contacts 2A  
 PROTECTION CLASS: IP 67  
 TEMPERATURE: -25°C / +85°C

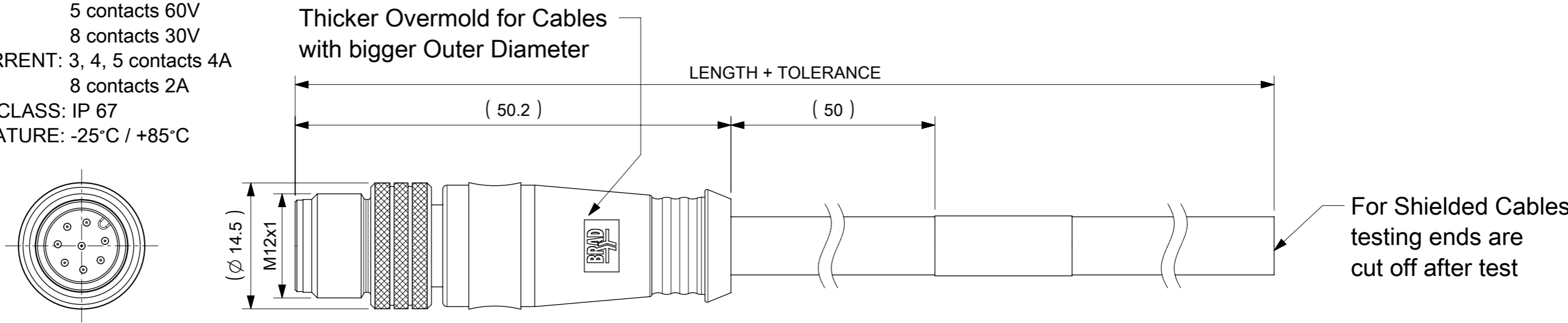

## CONTACTS POSITION FRONT VIEW:

3 CONTACTS		4 CONTACTS		5 CONTACTS		8 CONTACTS	
PIN	WIRE	PIN	WIRE	PIN	WIRE	PIN	WIRE
1	BROWN	1	BROWN	1	BROWN	1	WHITE
2	---	2	WHITE	2	WHITE	2	BROWN
3	BLUE	3	BLUE	3	BLUE	3	GREEN
4	BLACK	4	BLACK	4	BLACK	4	YELLOW
5	---	5	---	5	GRAY OR YELLOW/GREEN	5	GREY
						6	PINK
						7	BLUE
						8	RED

FOR OPTIONS SEE - NUMERICAL CODE - ON SHEET 2

ITEM	QTY.	DESCRIPTION	MATERIAL	FINISH
6	1	LABEL YELLOW	VINYL	---
	-	PRINTING FOR CABLES lxx	---	---
5	-	CABLE	SEE SHEET 2	---
4	-	OVERMOLDING BLACK	TPU	---
3	1	COUPLING NUT MALE	BRASS	NICKEL
2	1	INSERT MALE BLACK	PUR	---
1	3 / 4 / 5 / 8	CONTACT M12 MALE	BRASS	SELECTIVE Au OVER Ni

THIS DRAWING CONTAINS INFORMATION THAT IS PROPRIETARY TO MOLEX ELECTRONIC TECHNOLOGIES, LLC AND SHOULD NOT BE USED WITHOUT WRITTEN PERMISSION

FUNCTIONAL SYMBOLS:  $\nabla_A = 0$ ,  $\nabla_E = 0$ ,  $\nabla_V = 0$

DIVISIONAL SYMBOLS: 4 PLACES  $\pm$ , 3 PLACES  $\pm$ , 2 PLACES  $\pm 0.05$ , 1 PLACE  $\pm 0.1$ , 0 PLACES  $\pm 0.2$

GENERAL TOLERANCES (UNLESS SPECIFIED): DIMENSION UNITS: mm, SCALE: 2:1, ANGULAR TOL:  $\pm 1.0^\circ$

CURRENT REV DESC: EC NO: 638674, DRWN: PDZIECIOL, 2020/05/29, CHK'D: DSTACHOWIAK, 2020/06/01, APPR: DSTACHOWIAK, 2020/06/01

INITIAL REVISION: DRWN: JMARSZALEK, 2016/01/13, APPR: RSILLER, 2016/04/08

THIRD ANGLE PROJECTION:

DRAWING: A3-SIZE, SERIES: 120065, MATERIAL NUMBER: SEE SHEET 3, CUSTOMER: GENERAL MARKET, SHEET NUMBER: 1 OF 3

DOCUMENT NUMBER: 1200650971, DOC TYPE: PSD, DOC PART: 000, REVISION: A5

**molex**

CSE M12 XP AC MA STR XM SE UNSH

PRODUCT CUSTOMER DRAWING

CODING REQUIRED TO IEC 61076-2-101

ENGINEERING NO. - NUMERICAL CODE (Available parts see PART LIST table. Others on request).

8 0 X 0 0 6 X X X X X X X X

80=M12x1  
Single ended

Contacts:  
3=3 Contacts  
4=4 Contacts  
5=5 Contacts  
8=8 Contacts

Heads style:  
006=Plug Male Straight

Cable type: See Table

Units:  
M=Meter  
C=Centimeter

Length  
Examples:  
005=0.5 unit  
010=1 unit  
100=10 units

Overmold color:  
Blank (Standard)=Black TPU  
Blank=Yellow TPU for cables A09,S19,S20,S26  
Blank=Yellow TPE-E for cables K03,K05  
A=Grey / G=Black / Y=Yellow

Coupling Nut:  
Blank (Standard) & 3=Knurled Brass Ni Plated  
1=Hexagonal Stainless steel  
5=Knurled Derlin  
7=Knurled Brass Ni Plated, Teflon Coated  
Blank=7 for cables I20, I26, K03, K05, P82, S26  
9=Knurled / Hexagonal Brass Ni Plated SW13

H= 2 pcs. of I/D Carrier  
PVC Transparent  
(Cables Ixx & P82 always  
with 2 pcs. of I/D Carrier  
even if no H in  
Engineering No.)

COUPLING NUTS

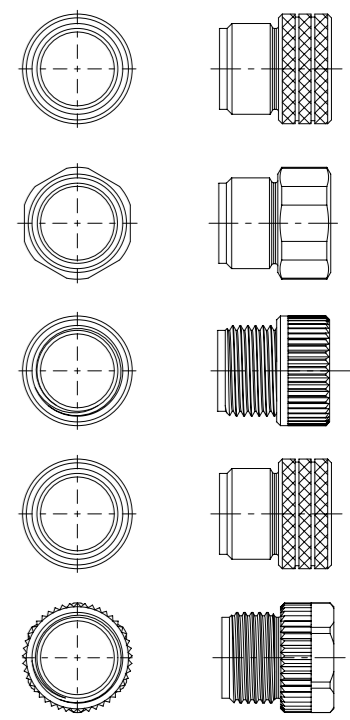

CABLE INFORMATION (for more information see Cable Data Sheet).

CABLE TYPE	NO. OF WIRES	CROSS SECTION	CABLE JACKET	UL	CSA	STATIC: TEMP. / BENDING RADIUS	DYNAMIC: TEMP. / BENDING RADIUS	DRAG CHAIN	SHIELD
E52	3 / 4 / 8	0.34mm <sup>2</sup>	PVC GREY	-	-	-30°C to +70°C	-5°C to +70°C	-	-
I02	3 / 4 / 8	0.25mm <sup>2</sup>	PVC CEI GREY	-	-	-30°C to +70°C	-5°C to +70°C	-	-
I03	3 / 4 / 5	0.34mm <sup>2</sup>	PVC CEI GREY	-	-	-30°C to +70°C	-5°C to +70°C	-	-
I20	3 / 4	0.34mm <sup>2</sup>	PVC CEI GREY	-	-	-30°C to +70°C	-5°C to +70°C	-	YES
I26	5	0.34mm <sup>2</sup>	PVC CEI GREY	-	-	-30°C to +70°C	-5°C to +70°C	-	-
K03	4 / 5	0.34mm <sup>2</sup>	TPE YELLOW	UL JEC 60332-1 or PLCT	I/II 90°C/300V	-	-	-	-
K05	3 / 4 / 5	0.34mm <sup>2</sup>	TPE YELLOW	UL ITC E195601 or PLC	I/II A/B 90°C/300V	-	-	-	-
P04	4	0.50mm <sup>2</sup>	PUR BLACK	-	-	-40°C to +90°C, 7.5xO.D.	-15°C to +90°C, 12.5xO.D.	-	-
P12	3 / 5	0.50mm <sup>2</sup>	PUR BLACK	-	-	-30°C to +90°C	-5°C to +90°C	-	-
P20	3 / 4 / 5	0.34mm <sup>2</sup>	PUR BLACK LS0H	-	-	-30°C to +80°C	-	-	YES
P82	3 / 4 / 5	0.34mm <sup>2</sup>	PUR IRR ORANGE	-	-	-50°C to +105°C, 5xO.D.	-40°C to +105°C, 7.5xO.D.	-	-
S19	8	0.25mm <sup>2</sup>	PVC YELLOW	UL 2661/1569	C22.2 II A 105°C/300V	-30°C to +105°C, 10xO.D.	-15°C to +105°C, 15xO.D.	-	YES
S20	3 / 4 / 5	0.34mm <sup>2</sup>	PVC YELLOW	UL 2661/1731	C22.2 II A 105°C/300V	-30°C to +105°C	-	-	YES
S26	5	0.34mm <sup>2</sup>	PVC YELLOW	UL 2661/1731	C22.2 II A 105°C/300V	-30°C to +105°C	-	-	YES

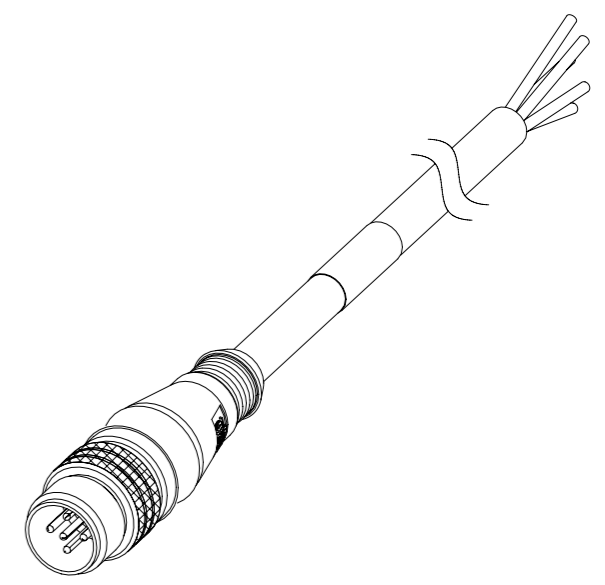

SCALE 1:1

CABLE LENGTH TOLERANCES	
LENGTH	TOLERANCE
0m-1m	+40 mm
>1m-5m	+60 mm
>5m-10m	+80 mm
>10m-20m	+140 mm
>20m-30m	+160 mm
>30m	+1% length

FUNCTIONAL SYMBOLS	THIS DRAWING CONTAINS INFORMATION THAT IS PROPRIETARY TO MOLEX ELECTRONIC TECHNOLOGIES, LLC AND SHOULD NOT BE USED WITHOUT WRITTEN PERMISSION	CURRENT REV DESC:																								
	<table border="1"> <tr> <th>FUNCTIONAL SYMBOLS</th> <th>DIMENSION UNITS</th> <th>SCALE</th> </tr> <tr> <td><math>\sqrt{A}</math> = 0</td> <td>mm</td> <td>1:1</td> </tr> <tr> <td><math>\sqrt{E}</math> = 0</td> <td colspan="2">GENERAL TOLERANCES (UNLESS SPECIFIED)</td> </tr> <tr> <td><math>\sqrt{V}</math> = 0</td> <td colspan="2">ANGULAR TOL ± 1.0°</td> </tr> <tr> <td rowspan="5">DIVISIONAL SYMBOLS</td> <td>4 PLACES</td> <td>±</td> </tr> <tr> <td>3 PLACES</td> <td>±</td> </tr> <tr> <td>2 PLACES</td> <td>± 0.05</td> </tr> <tr> <td>1 PLACE</td> <td>± 0.1</td> </tr> <tr> <td>0 PLACES</td> <td>± 0.2</td> </tr> </table>	FUNCTIONAL SYMBOLS	DIMENSION UNITS		SCALE	$\sqrt{A}$ = 0	mm	1:1	$\sqrt{E}$ = 0	GENERAL TOLERANCES (UNLESS SPECIFIED)		$\sqrt{V}$ = 0	ANGULAR TOL ± 1.0°		DIVISIONAL SYMBOLS	4 PLACES	±	3 PLACES	±	2 PLACES	± 0.05	1 PLACE	± 0.1	0 PLACES	± 0.2	EC NO: 638674 DRWN: PDZIECIOL 2020/05/29 CHK'D: DSTACHOWIAK 2020/06/01 APPR: DSTACHOWIAK 2020/06/01
FUNCTIONAL SYMBOLS	DIMENSION UNITS	SCALE																								
$\sqrt{A}$ = 0	mm	1:1																								
$\sqrt{E}$ = 0	GENERAL TOLERANCES (UNLESS SPECIFIED)																									
$\sqrt{V}$ = 0	ANGULAR TOL ± 1.0°																									
DIVISIONAL SYMBOLS	4 PLACES	±																								
	3 PLACES	±																								
	2 PLACES	± 0.05																								
	1 PLACE	± 0.1																								
	0 PLACES	± 0.2																								
PRODUCT CUSTOMER DRAWING			DOCUMENT NUMBER: 1200650971	DOC TYPE: PSD DOC PART: 000 REVISION: A5																						
DRAFT WHERE APPLICABLE MUST REMAIN WITHIN DIMENSIONS		THIRD ANGLE PROJECTION	DRAWING: A3-SIZE	SERIES: 120065																						
MATERIAL NUMBER: SEE SHEET 3		CUSTOMER: GENERAL MARKET		SHEET NUMBER: 2 OF 3																						

# PART LIST

No.	Part No.	Engineering No.	Cable Length
1	1200060243	803006E52M050A	5m
2	1200060252	803006I03M020	2m
3	1200060253	803006I03M030	3m
4	1200060254	803006I03M050	5m
5	1200060565	804006I03M020	2m
6	1200060567	804006I03M050	5m
7	1200060568	804006I03M100	10m
8	1200060573	804006P82M0107	1m
9	1200060574	804006P82M020	2m
10	1200060576	804006P82M0507	5m
11	1200060578	804006S20M010	1m
12	1200060579	804006S20M020	2m
13	1200060581	804006S20M100	10m
14	1200060674	805006I03M005	0.5m
15	1200060675	805006I03M020	2m
16	1200060684	805006S26M020	2m
17	1200061023	804006I20M003	0.3m
18	1200061551	803006S20M050	5m
19	1200061663	804006E52M100A	10m
20	1200061664	804006E52M200A	20m
21	1200061781	805006I26M050	5m
22	1200062465	804006P82M0207	2m
23	1200062540	805006P12M010	1m
24	1200062541	805006P12M015	1.5m
25	1200062606	803006S20M100	10m
26	1200062618	805006P12M0035	0.3m
27	1200062770	805006P12M030	3m
28	1200063282	805006P20M010	1m
29	1200063355	803006P12M0023	0.2m
30	1200063371	805006P12M050	5m
31	1200064014	803006P82M0067	0.6m
32	1200064375	803006P82M0107	1m
33	1200064444	805006I03C150	0.15m
34	1200650971	808006S19M010	1m
35	1200651133	804006K05M100	10m

No.	Part No.	Engineering No.	Cable Length
36	1200651788	804006E52M005A	0.5m
37	1200651790	804006E52M050A	5m
38	1200658029	804006P82M0057	0.5m
39	1200658095	805006S26M100	10m
40	1200658170	805006S26M050	5m
41	1200658201	804006S20M050	5m
42	1200658325	804006I03M010	1m
43	1200658497	804006P20M150	15m
44	1200658595	803006I03M040	4m
45	1200658601	804006I03M040	4m
46	1200658689	808006I02M010	1m
47	1200658690	808006I02M020	2m
48	1200658691	808006I02M030	3m
49	1200658692	808006I02M040	4m
50	1200658693	808006I02M050	5m
51	1200658694	808006I02M100	10m
52	1200658809	804006P04M003	0.3m
53	1200658961	804006S20M0201	2m
54	1200658962	804006S20M1001	10m
55	1200658965	804006S20M0501	5m
56	1200658973	805006S20M050	5m
57	1200659089	804006P82M0207Y	2m
58	1200659096	804006P82M0057Y	0.5m
59	1200659122	804006I03M050Y	5m
60	1200659171	804006I03M050A	5m
61	1200659174	805006S26M050H	5m
62	1200659347	804006S20M350	35m
63	1200659364	804006S20M010H	1m
64	1200699506	808006S19M020	2m
65	1200699507	808006S19M030	3m
66	1200699508	808006S19M050	5m
67	1200699509	808006S19M100	10m
68	1200064547	804006K03M100	10m
69	1200652151	805006K03M050	5m
70	1200651129	804006K05M020	2m

No.	Part No.	Engineering No.	Cable Length
71	1200651131	804006K05M050	5m
72	1200651374	805006K03M020	2m
73			
74			
75			
76			
77			
78			
79			
80			
81			
82			
83			
84			
85			
86			
87			
88			
89			
90			
91			
92			
93			
94			
95			
96			
97			
98			
99			
100			
101			
102			
103			
104			
105			

Pos.	Part No.	Engineering No.	Cable Length
106			
107			
108			
109			
110			
111			
112			
113			
114			
115			
116			
117			
118			
119			
120			
121			
122			
123			
124			
125			
126			
127			
128			
129			
130			
131			
132			
133			
134			
135			
136			
137			
138			
139			
140			

<b>FUNCTIONAL SYMBOLS</b> = 0 = 0 = 0	THIS DRAWING CONTAINS INFORMATION THAT IS PROPRIETARY TO MOLEX ELECTRONIC TECHNOLOGIES, LLC AND SHOULD NOT BE USED WITHOUT WRITTEN PERMISSION		<b>CURRENT REV DESC:</b>	
	DIMENSION UNITS: <b>mm</b> SCALE: <b>1:1</b>	<b>GENERAL TOLERANCES (UNLESS SPECIFIED)</b> ANGULAR TOL ± 1.0° 4 PLACES ± 3 PLACES ± 2 PLACES ± 0.05 1 PLACE ± 0.1 0 PLACES ± 0.2		
<b>DIVISIONAL SYMBOLS</b>	DRAFT WHERE APPLICABLE MUST REMAIN WITHIN DIMENSIONS		THIRD ANGLE PROJECTION	DRAWING: <b>A3-SIZE</b> SERIES: <b>120065</b> MATERIAL NUMBER: <b>SEE PART LIST</b> CUSTOMER: <b>GENERAL MARKET</b>
INITIAL REVISION: DRWN: JMARSZALEK 2016/01/13 APPR: RSILLER 2016/04/08		DOCUMENT NUMBER: <b>1200650971</b> DOC TYPE: <b>PSD</b> DOC PART: <b>000</b> REVISION: <b>A5</b>		SHEET NUMBER: <b>3 OF 3</b>

PART NO.	ENGINEERING NO.	FINISHED LENGTH	POLES	CABLE DIA
1200651114	803006K05M020	2.0M [6'7"]	3	.20/5.1
1200651363	804006K05M030	3.0M [9'10"]	4	.21/5.3
1200652467	805001K05M100	10.0M [32'10"]	5	.23/5.8

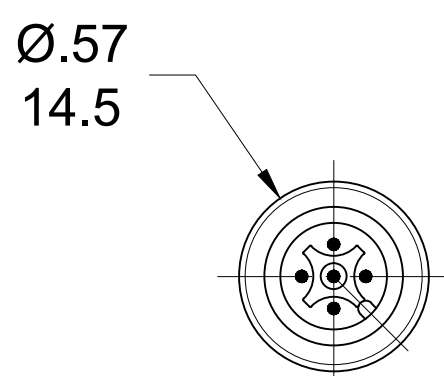
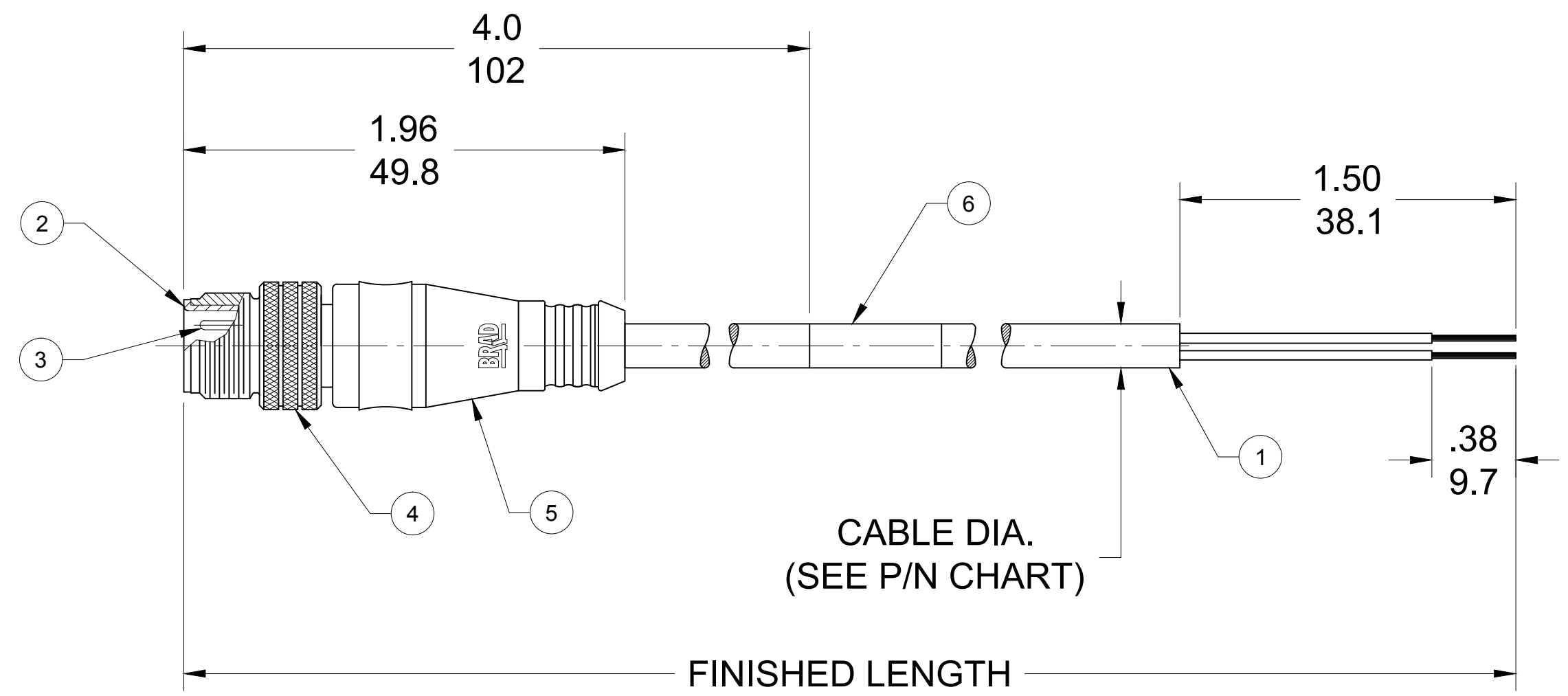
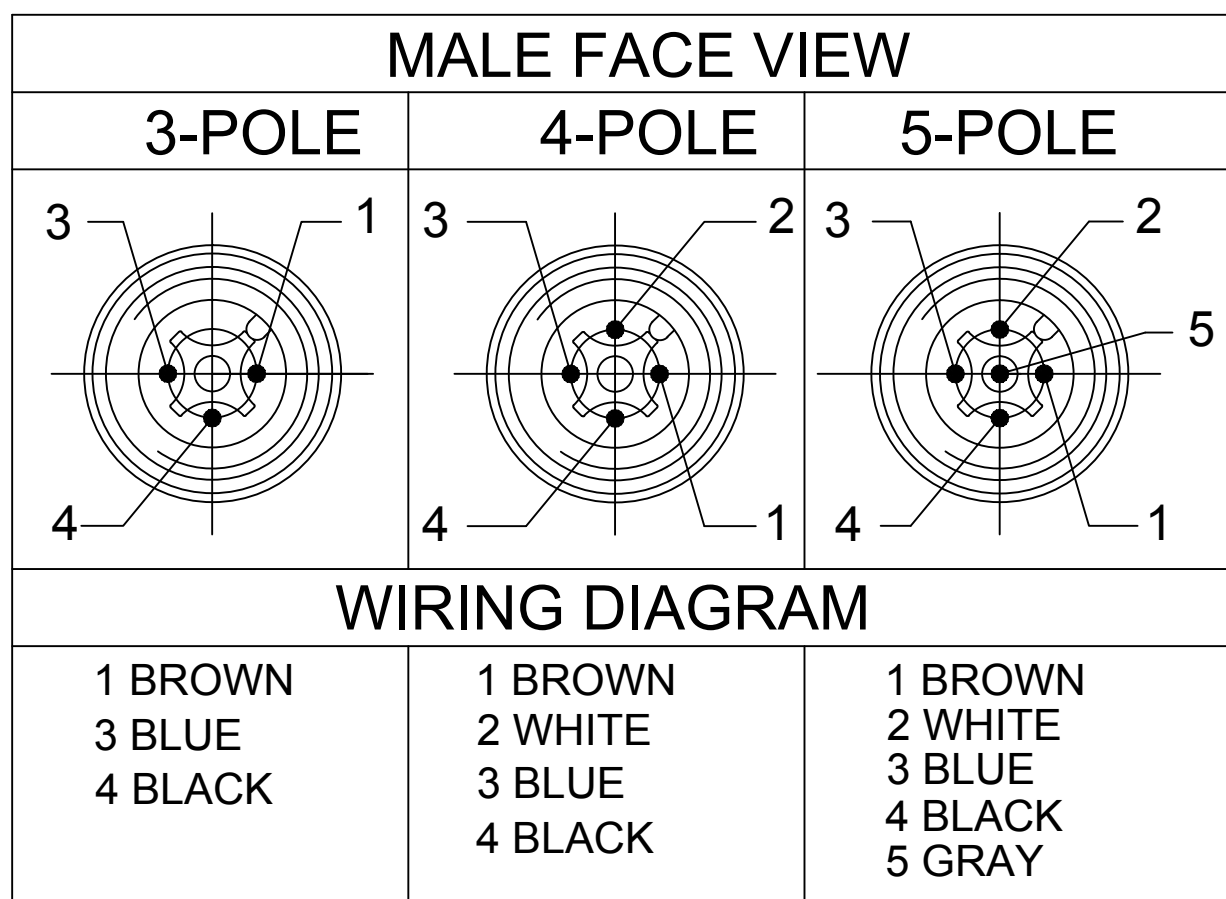

**PART NO. LEGEND**

**803006K05M020**

POLES: 3,4 & 5

CABLE TYPE: 22AWG TPE YELLOW

FINISHED LENGTH: M005----0.5 Meters, M010----1.0 Meter, M100----10 Meters

- NOTES:**
- MATERIAL: AS NOTED
  - FINISH: AS NOTED
  - ELECTRICAL: VOLTAGE: 250V, CURRENT: 4A
  - TEMP RATING: -25°TO +105°C
  - PROTECTION: IP67 (WHEN MATED)
  - COUPLING THREAD: M12 X 1
  - UL RECOGNIZED FILE: E152210, CSA CERTIFIED FILE: LR6837
  - ALL DIMS ARE FOR REFERENCE UNLESS NOTED OTHERWISE

**CABLE FLEX CHARACTERISTICS**

TORSIONAL FLEX TEST	10 MILLION CYCLES PER MIL-C-13777G
BEND FLEX TEST	10 MILLION CYCLES PER MIL-C-13777G
WELD SLAG RESISTANCE	WOODHEAD STANDARD S-300

**CABLE LENGTH TOLERANCES**

>.3M [1FT]:	+19mm-0 [+ .75in-0]
.3 - .9M [1 - 3FT]:	+44.5mm-0 [+1.75in-0]
.9 - 1.8M [3 - 6FT]:	+55.6mm-0 [+2.19in-0]
1.8 - 3.7M [6 - 12FT]:	+88.9mm-0 [+3.50in-0]
3.7 - 7.3M [12 - 24FT]:	+165.1mm-0 [+6.50in-0]
7.3-14.6M [24 - 48FT]:	+317.5mm-0 [+12.50in-0]
14.6 - 30.5M [48-100FT]:	+622.3mm-0 [+24.50in-0]
OVER 30M [100FT]	+2% OF FINISHED LENGTH

ITEM	DESCRIPTION	MATERIAL	FINISH
6	WRAP LABEL	VINYL	BLACK/YELLOW
5	OVERMOLD	TPE	YELLOW
4	COUPLING NUT	BRASS	NICKEL PLATED
3	CONTACT PIN	COPPER ALLOY	GOLD PLATED
2	MALE INSERT	PUR	BLACK
1	CABLE, 22AWG, 300V, 105°	TPE JACKET	YELLOW

EC NO: IPG2019-0189 DRWN: RSTONE 2018/11/01 CHKD: C CHRAST 2018/11/07 APPR: BWOODMAN2018/11/30 REV A	<b>QUALITY SYMBOL</b> ▽=0 ▽=0	<b>GENERAL TOLERANCES (UNLESS SPECIFIED)</b> <table border="1"> <tr> <th></th> <th>mm</th> <th>INCH</th> </tr> <tr> <td>4 PLACES</td> <td>±---</td> <td>±---</td> </tr> <tr> <td>3 PLACES</td> <td>±---</td> <td>±---</td> </tr> <tr> <td>2 PLACES</td> <td>±---</td> <td>±---</td> </tr> <tr> <td>1 PLACE</td> <td>±---</td> <td>±---</td> </tr> </table>		mm	INCH	4 PLACES	±---	±---	3 PLACES	±---	±---	2 PLACES	±---	±---	1 PLACE	±---	±---	<b>DIMENSION STYLE</b> IN/MM	SCALE --- DESIGN UNITS INCH THIRD ANGLE PROJECTION
		mm	INCH																
	4 PLACES	±---	±---																
	3 PLACES	±---	±---																
2 PLACES	±---	±---																	
1 PLACE	±---	±---																	
DRAFT WHERE APPLICABLE MUST REMAIN WITHIN DIMENSIONS		DRAWN BY: RSTONE DATE: 2018/11/01 CHECKED BY: C CHRAST DATE: 2018/11/07 APPROVED BY: BWOODMAN DATE: 2018/11/30	TITLE: MIC CABLE ASSY M12 MALE STRAIGHT 22AWG, TPE YELLOW																
MATERIAL NO. SEE P/N CHART		MOLEX INCORPORATED		SHEET NO. 1 OF 1															
THIS DRAWING CONTAINS INFORMATION THAT IS PROPRIETARY TO MOLEX INCORPORATED AND SHOULD NOT BE USED WITHOUT WRITTEN PERMISSION																			