



# STB18NM80, STF18NM80, STP18NM80, STW18NM80

N-channel 800 V, 0.25  $\Omega$ , 17 A, MDmesh™ Power MOSFET  
in D<sup>2</sup>PAK, TO-220FP, TO-220 and TO-247 packages

Datasheet — production data

## Features

| Order codes | V <sub>DSS</sub> | R <sub>DS(on) max</sub> | I <sub>D</sub>      |
|-------------|------------------|-------------------------|---------------------|
| STB18NM80   | 800 V            | < 0.295 $\Omega$        | 17 A                |
| STF18NM80   | 800 V            | < 0.295 $\Omega$        | 17 A <sup>(1)</sup> |
| STP18NM80   | 800 V            | < 0.295 $\Omega$        | 17 A                |
| STW18NM80   | 800 V            | < 0.295 $\Omega$        | 17 A                |

1. Limited only by maximum temperature allowed

- 100% avalanche tested
- Low input capacitance and gate charge
- Low gate input resistance

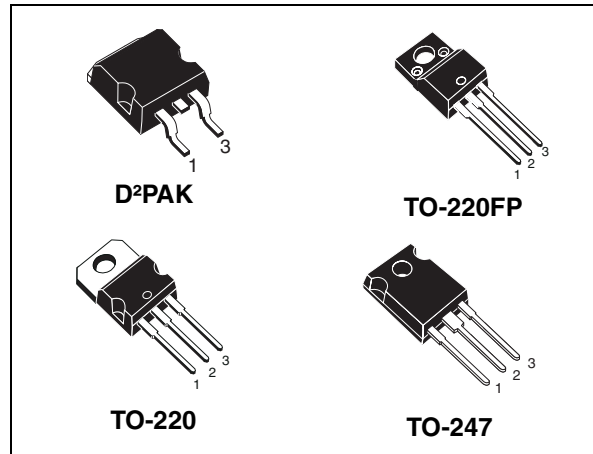

## Application

- Switching applications

## Description

These N-channel Power MOSFETs are developed using STMicroelectronics' revolutionary MDmesh™ technology, which associates the multiple drain process with the company's PowerMESH™ horizontal layout. These devices offer extremely low on-resistance, high dv/dt and excellent avalanche characteristics. Utilizing ST's proprietary strip technique, these Power MOSFETs boast an overall dynamic performance which is superior to similar products on the market.

Figure 1. Internal schematic diagram

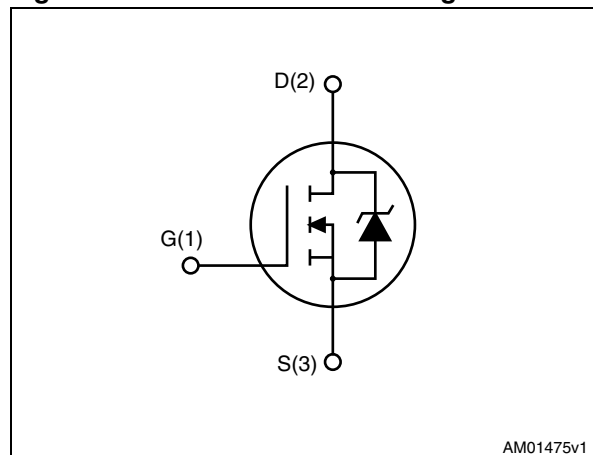

Table 1. Device summary

| Order codes | Marking | Package            | Packaging     |
|-------------|---------|--------------------|---------------|
| STB18NM80   | 18NM80  | D <sup>2</sup> PAK | Tape and reel |
| STF18NM80   |         | TO-220FP           | Tube          |
| STP18NM80   |         | TO-220             |               |
| STW18NM80   |         | TO-247             |               |

## Contents

|          |   |           |
|----------|---|-----------|
| <b>1</b> | <b>Electrical ratings</b> .....           | <b>3</b>  |
| <b>2</b> | <b>Electrical characteristics</b> .....   | <b>4</b>  |
| 2.1      | Electrical characteristics (curves) ..... | 6         |
| <b>3</b> | <b>Test circuits</b> .....                | <b>9</b>  |
| <b>4</b> | <b>Package mechanical data</b> .....      | <b>10</b> |
| <b>5</b> | <b>Packaging mechanical data</b> .....    | <b>18</b> |
| <b>6</b> | <b>Revision history</b> .....             | <b>20</b> |

# 1 Electrical ratings

**Table 2. Absolute maximum ratings**

| Symbol                         | Parameter   | Value      |                    |                      |          | Unit |
|--------------------------------|---|------------|--------------------|----------------------|----------|------|
|                                |   | TO-220     | D <sup>2</sup> PAK | TO-247               | TO-220FP |      |
| V <sub>DS</sub>                | Drain-source voltage  | 800        |                    |                      |          | V    |
| V <sub>GS</sub>                | Gate-source voltage   | ± 30       |                    |                      |          | V    |
| I <sub>D</sub>                 | Drain current (continuous) at T <sub>C</sub> = 25 °C  | 17         |                    | 17 <sup>(1)</sup>    |          | A    |
| I <sub>D</sub>                 | Drain current (continuous) at T <sub>C</sub> = 100 °C   | 10.71      |                    | 10.71 <sup>(1)</sup> |          | A    |
| I <sub>DM</sub> <sup>(2)</sup> | Drain current (pulsed)  | 68         |                    | 68 <sup>(1)</sup>    |          | A    |
| P <sub>TOT</sub>               | Total dissipation at T <sub>C</sub> = 25 °C   | 190        |                    | 40                   |          | W    |
| V <sub>ISO</sub>               | Insulation withstand voltage (RMS) from all three leads to external heat sink (t = 1 s; T <sub>C</sub> = 25 °C) | 2500       |                    |                      |          | V    |
| T <sub>stg</sub>               | Storage temperature   | -65 to 150 |                    |                      |          | °C   |
| T <sub>j</sub>                 | Max. operating junction temperature   | 150        |                    |                      |          | °C   |

1. Limited only by maximum temperature allowed
2. Pulse width limited by safe operating area

**Table 3. Thermal data**

| Symbol                | Parameter                                      | Value  |                    |        |          | Unit |
|-----------------------|--|--------|--------------------|--------|----------|------|
|                       |  | TO-220 | D <sup>2</sup> PAK | TO-247 | TO-220FP |      |
| R <sub>thj-case</sub> | Thermal resistance junction-case               | 0.66   |                    | 3.13   |          | °C/W |
| R <sub>thj-amb</sub>  | Thermal resistance junction-amb                | 62.5   |                    | 50     | 62.5     | °C/W |
| R <sub>thj-pcb</sub>  | Thermal resistance junction-pcb                |        | 30                 |        |          | °C/W |
| T <sub>l</sub>        | Maximum lead temperature for soldering purpose | 300    |                    |        |          | °C   |

**Table 4. Avalanche characteristics**

| Symbol          | Parameter  | Max value | Unit |
|-----------------|--|-----------|------|
| I <sub>AS</sub> | Avalanche current, repetitive or not-repetitive (pulse width limited by T <sub>j</sub> max)                                | 4         | A    |
| E <sub>AS</sub> | Single pulse avalanche energy (starting T <sub>j</sub> = 25 °C, I <sub>D</sub> = I <sub>AS</sub> , V <sub>DD</sub> = 50 V) | 600       | mJ   |

## 2 Electrical characteristics

( $T_{CASE} = 25\text{ °C}$  unless otherwise specified)

**Table 5. On/off states**

| Symbol        | Parameter  | Test conditions  | Min. | Typ. | Max.      | Unit                           |
|---------------|--|--|------|------|-----------|--------------------------------|
| $V_{(BR)DSS}$ | Drain-source breakdown voltage                   | $I_D = 1\text{ mA}$ , $V_{GS} = 0$   | 800  |      |           | V                              |
| $I_{DSS}$     | Zero gate voltage drain current ( $V_{GS} = 0$ ) | $V_{DS} = 800\text{ V}$ ,<br>$V_{DS} = 800\text{ V}$ , $T_C = 125\text{ °C}$ |      |      | 10<br>100 | $\mu\text{A}$<br>$\mu\text{A}$ |
| $I_{GSS}$     | Gate body leakage current ( $V_{DS} = 0$ )       | $V_{GS} = \pm 30\text{ V}$   |      |      | $\pm 100$ | nA                             |
| $V_{GS(th)}$  | Gate threshold voltage                           | $V_{DS} = V_{GS}$ , $I_D = 250\text{ }\mu\text{A}$                           | 3    | 4    | 5         | V                              |
| $R_{DS(on)}$  | Static drain-source on-resistance                | $V_{GS} = 10\text{ V}$ , $I_D = 8.5\text{ A}$                                |      | 0.25 | 0.295     | $\Omega$                       |

**Table 6. Dynamic**

| Symbol                              | Parameter   | Test conditions   | Min. | Typ.              | Max. | Unit           |
|-------------------------------------|---|---|------|-------------------|------|----------------|
| $g_{fs}^{(1)}$                      | Forward transconductance  | $V_{DS} = 15\text{ V}$ , $I_D = 8.5\text{ A}$   | -    | 14                | -    | S              |
| $C_{iss}$<br>$C_{oss}$<br>$C_{rss}$ | Input capacitance<br>Output capacitance<br>Reverse transfer capacitance | $V_{DS} = 50\text{ V}$ , $f = 1\text{ MHz}$ , $V_{GS} = 0$  | -    | 2070<br>210<br>29 | -    | pF<br>pF<br>pF |
| $C_{oss\text{ eq.}}^{(2)}$          | Equivalent output capacitance   | $V_{GS} = 0$ , $V_{DS} = 0\text{ to }640\text{ V}$  | -    | 316               | -    | pF             |
| $R_G$                               | Gate input resistance   | $f = 1\text{ MHz}$ Gate DC Bias = 0<br>Test Signal Level = 20 mV<br>Open Drain                              | -    | 4                 | -    | $\Omega$       |
| $Q_g$<br>$Q_{gs}$<br>$Q_{gd}$       | Total gate charge<br>Gate-source charge<br>Gate-drain charge            | $V_{DD} = 640\text{ V}$ , $I_D = 17\text{ A}$<br>$V_{GS} = 10\text{ V}$<br>(see <a href="#">Figure 17</a> ) | -    | 70<br>13<br>40    | -    | nC<br>nC<br>nC |

1. Pulsed: pulse duration = 300 $\mu\text{s}$ , duty cycle 1.5%
2.  $C_{oss\text{ eq.}}$  is defined as a constant equivalent capacitance giving the same charging time as  $C_{oss}$  when  $V_{DS}$  increases from 0 to 80%  $V_{DSS}$

**Table 7. Switching times**

| Symbol       | Parameter           | Test conditions   | Min. | Typ. | Max. | Unit |    |
|--------------|---------------------|---|------|------|------|------|----|
| $t_{d(on)}$  | Turn-on delay time  | $V_{DD} = 400\text{ V}$ , $I_D = 8.5\text{ A}$ ,<br>$R_G = 4.7\ \Omega$ , $V_{GS} = 10\text{ V}$<br>(see <a href="#">Figure 16</a> and<br><a href="#">Figure 21</a> ) |      | 18   |      | ns   |    |
| $t_r$        | Rise time           |   |      | 28   |      | ns   |    |
| $t_{d(off)}$ | Turn-off delay time |   |      |      | 96   |      | ns |
| $t_f$        | Fall time           |   |      |      | 50   |      | ns |

**Table 8. Source drain diode**

| Symbol          | Parameter                     | Test conditions   | Min. | Typ. | Max. | Unit          |
|-----------------|-------------------------------|---|------|------|------|---------------|
| $I_{SD}$        | Source-drain current          |   | -    |      | 17   | A             |
| $I_{SDM}^{(1)}$ | Source-drain current (pulsed) |   |      |      | 68   | A             |
| $V_{SD}^{(2)}$  | Forward on voltage            | $I_{SD} = 17\text{ A}$ , $V_{GS} = 0$   | -    |      | 1.6  | V             |
| $t_{rr}$        | Reverse recovery time         | $I_{SD} = 17\text{ A}$ , $di/dt = 100\text{ A}/\mu\text{s}$ ,<br>$V_{DD} = 100\text{ V}$ ,<br>(see <a href="#">Figure 18</a> )                              | -    | 618  |      | ns            |
| $Q_{rr}$        | Reverse recovery charge       |   |      | 9.6  |      | $\mu\text{C}$ |
| $I_{RRM}$       | Reverse recovery current      |   |      | 31.2 |      | A             |
| $t_{rr}$        | Reverse recovery time         | $I_{SD} = 17\text{ A}$ ,<br>$di/dt = 100\text{ A}/\mu\text{s}$ ,<br>$V_{DD} = 100\text{ V}$ , $T_j = 150^\circ\text{C}$<br>(see <a href="#">Figure 18</a> ) | -    | 822  |      | ns            |
| $Q_{rr}$        | Reverse recovery charge       |   |      | 13   |      | $\mu\text{C}$ |
| $I_{RRM}$       | Reverse recovery current      |   |      | 31.8 |      | A             |

1. Pulse width limited by safe operating area
2. Pulsed: pulse duration = 300  $\mu\text{s}$ , duty cycle 1.5%

## 2.1 Electrical characteristics (curves)

**Figure 2. Safe operating area for TO-220, D<sup>2</sup>PAK**

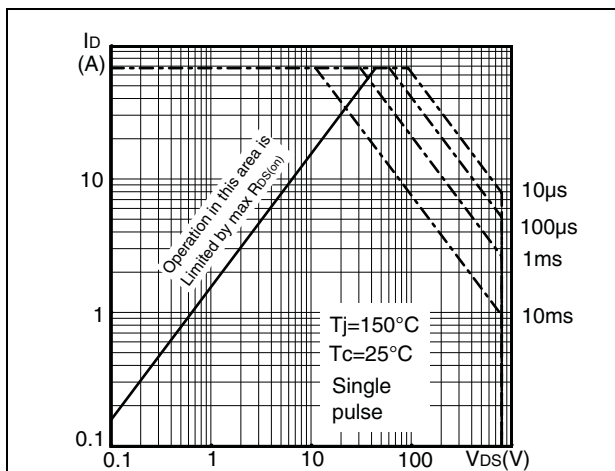

**Figure 3. Thermal impedance for TO-220, D<sup>2</sup>PAK**

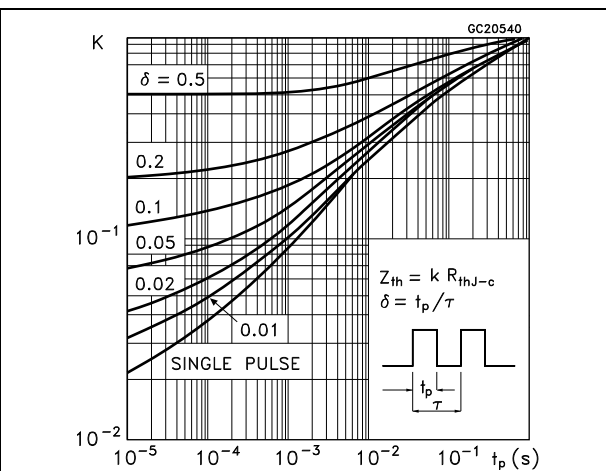

**Figure 4. Safe operating area for TO-247**

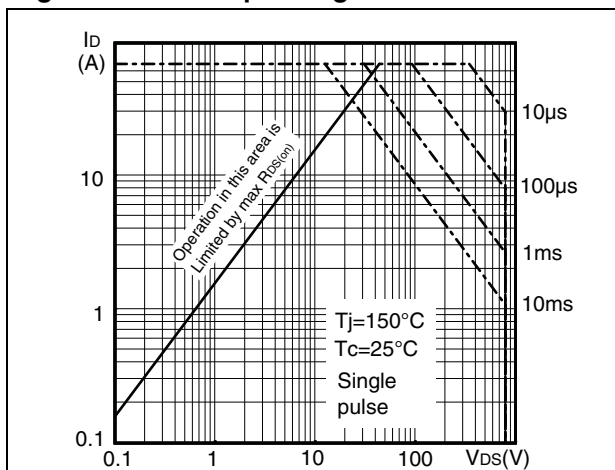

**Figure 5. Thermal impedance for TO-247**

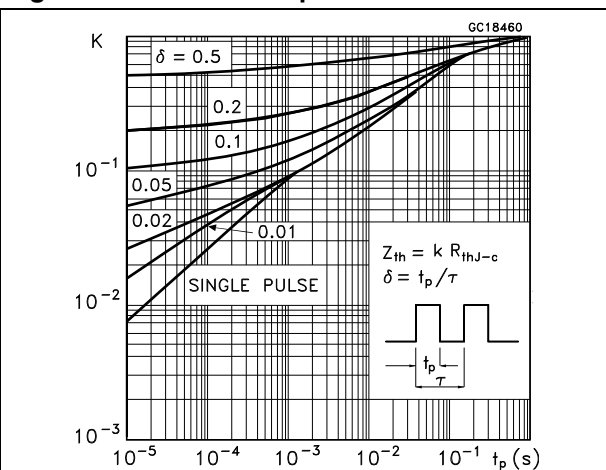

**Figure 6. Safe operating area for TO-220FP**

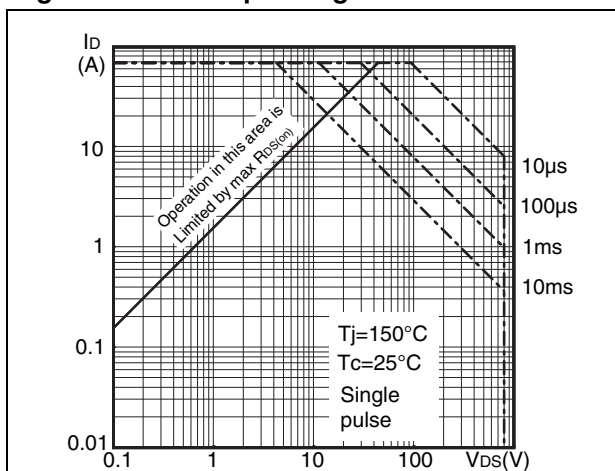

**Figure 7. Thermal impedance for TO-220FP**

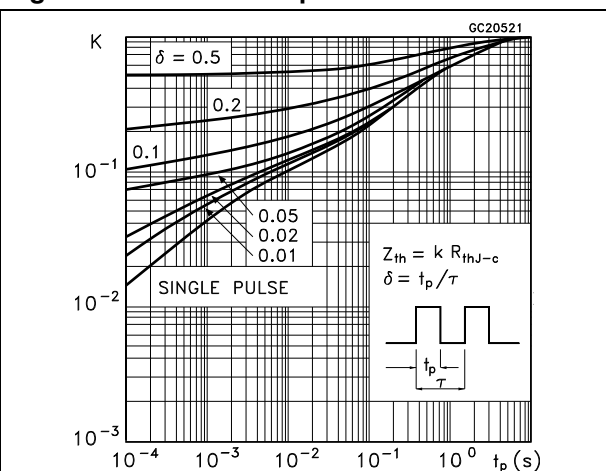

Figure 8. Output characteristics

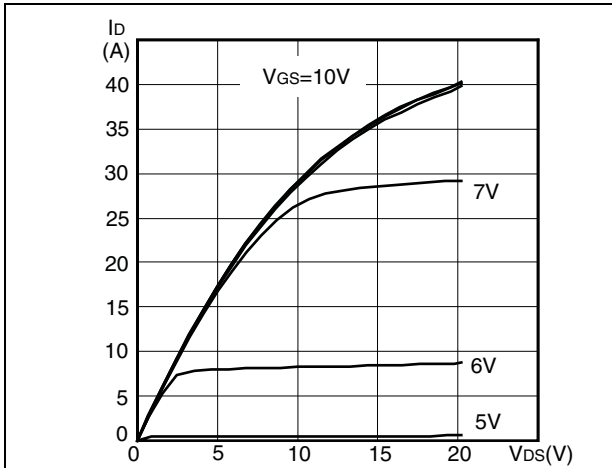

Figure 9. Transfer characteristics

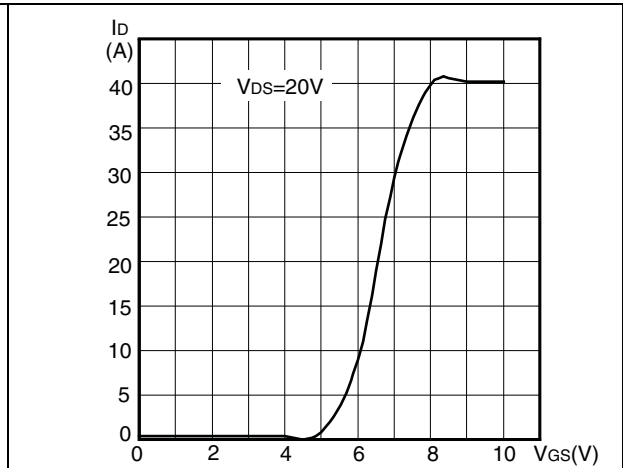

Figure 10. Normalized  $B_{V_{DSS}}$  vs temperature

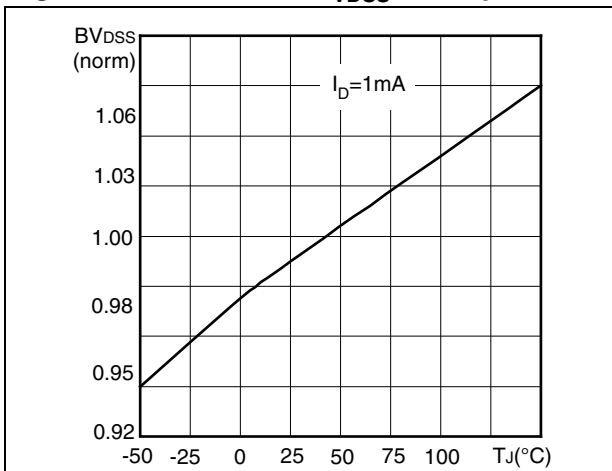

Figure 11. Static drain-source on-resistance

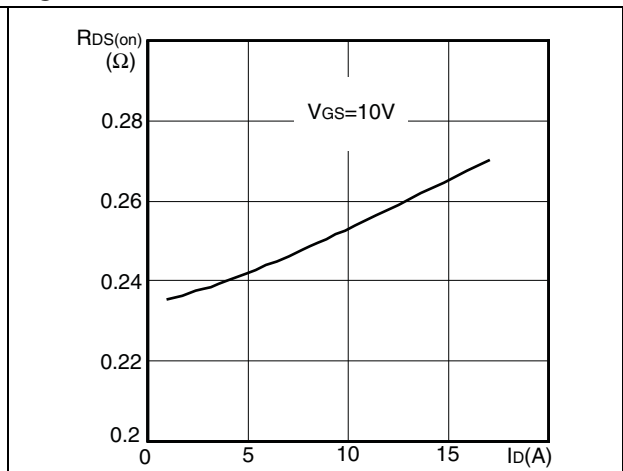

Figure 12. Gate charge vs gate-source voltage

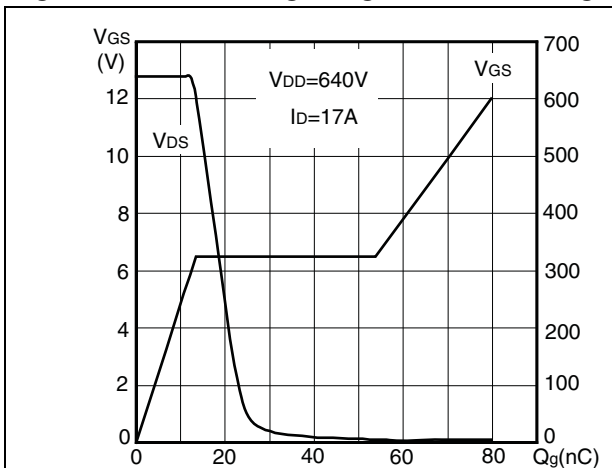

Figure 13. Capacitance variations

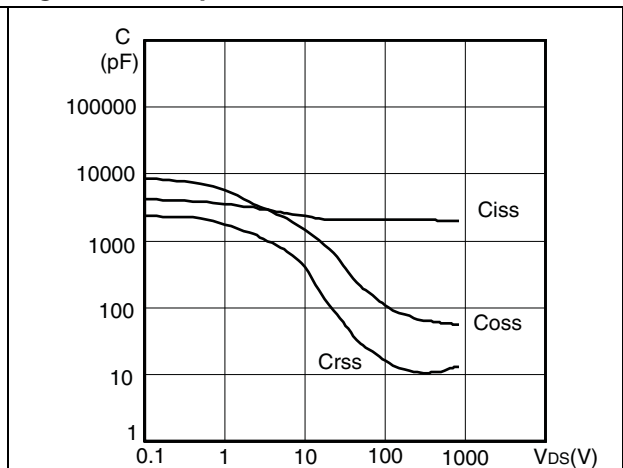

Figure 14. Normalized gate threshold voltage vs temperature

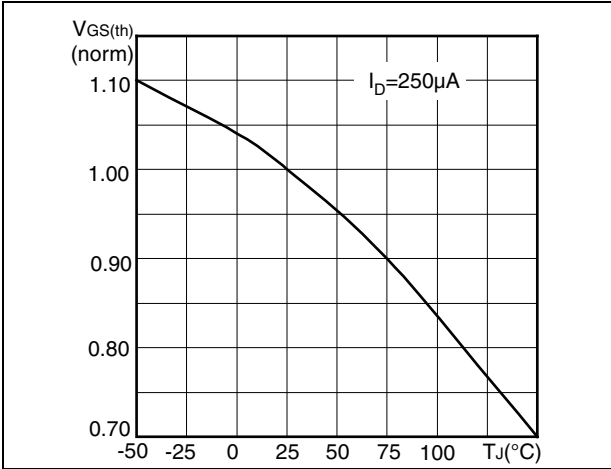
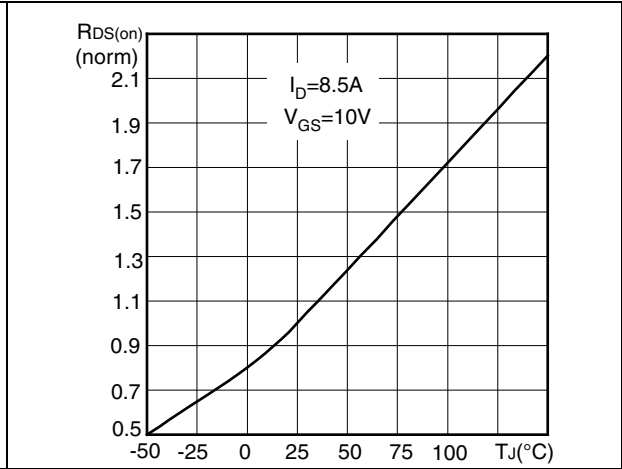

Figure 15. Normalized on-resistance vs temperature





### 3 Test circuits

**Figure 16. Switching times test circuit for resistive load**

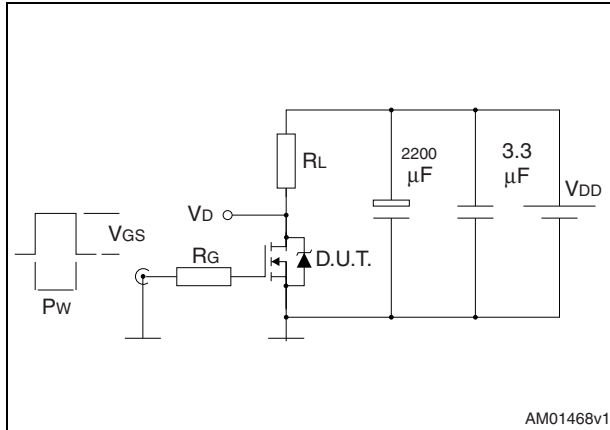

**Figure 17. Gate charge test circuit**

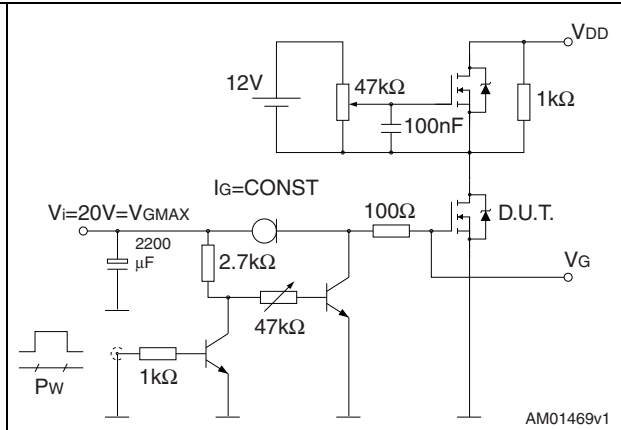

**Figure 18. Test circuit for inductive load switching and diode recovery times**

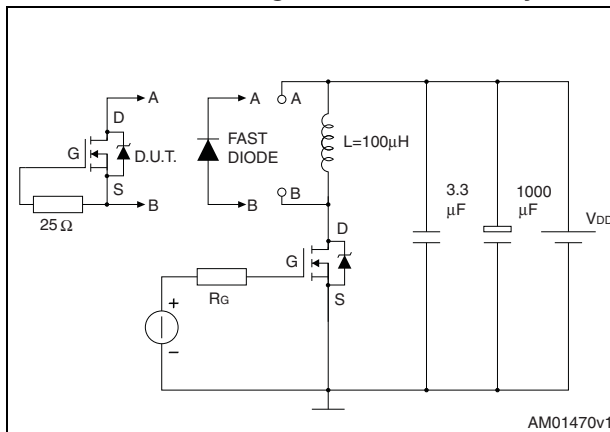

**Figure 19. Unclamped inductive load test circuit**

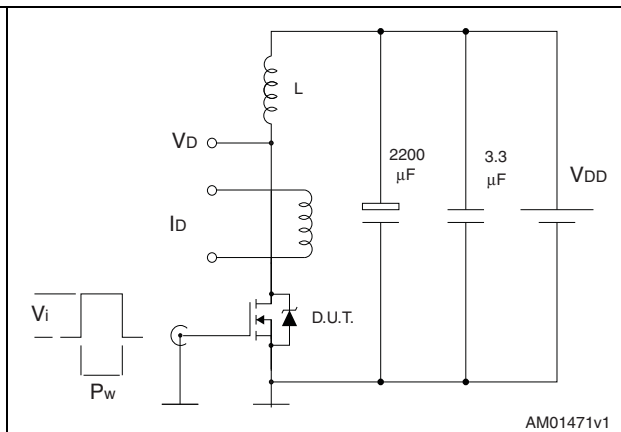

**Figure 20. Unclamped inductive waveform**

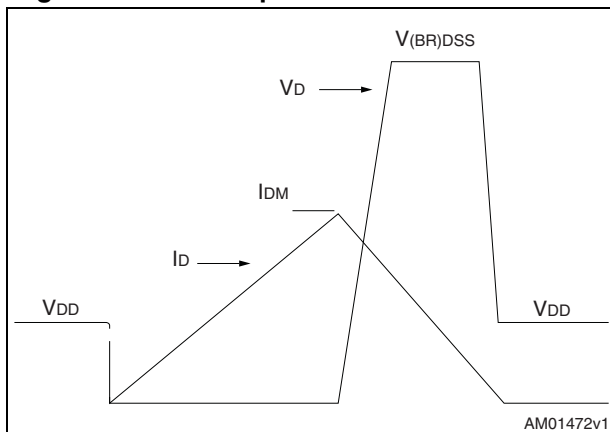

**Figure 21. Switching time waveform**

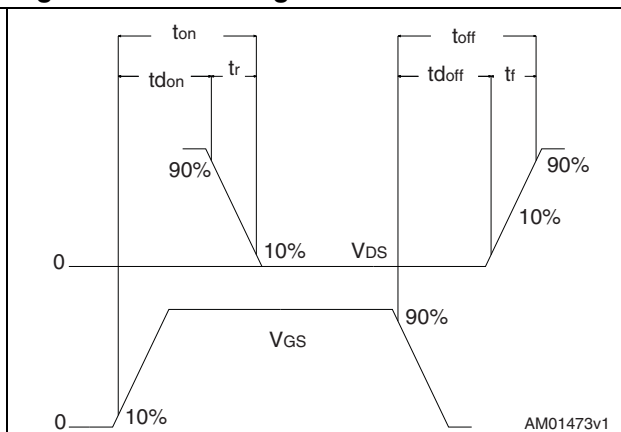

## 4 Package mechanical data

In order to meet environmental requirements, ST offers these devices in different grades of ECOPACK<sup>®</sup> packages, depending on their level of environmental compliance. ECOPACK<sup>®</sup> specifications, grade definitions and product status are available at: [www.st.com](http://www.st.com). ECOPACK is an ST trademark.

**Table 9. D<sup>2</sup>PAK (TO-263) mechanical data**

| Dim. | mm   |      |       |
|------|------|------|-------|
|      | Min. | Typ. | Max.  |
| A    | 4.40 |      | 4.60  |
| A1   | 0.03 |      | 0.23  |
| b    | 0.70 |      | 0.93  |
| b2   | 1.14 |      | 1.70  |
| c    | 0.45 |      | 0.60  |
| c2   | 1.23 |      | 1.36  |
| D    | 8.95 |      | 9.35  |
| D1   | 7.50 |      |       |
| E    | 10   |      | 10.40 |
| E1   | 8.50 |      |       |
| e    |      | 2.54 |       |
| e1   | 4.88 |      | 5.28  |
| H    | 15   |      | 15.85 |
| J1   | 2.49 |      | 2.69  |
| L    | 2.29 |      | 2.79  |
| L1   | 1.27 |      | 1.40  |
| L2   | 1.30 |      | 1.75  |
| R    |      | 0.4  |       |
| V2   | 0°   |      | 8°    |

Figure 22. D<sup>2</sup>PAK (TO-263) drawing

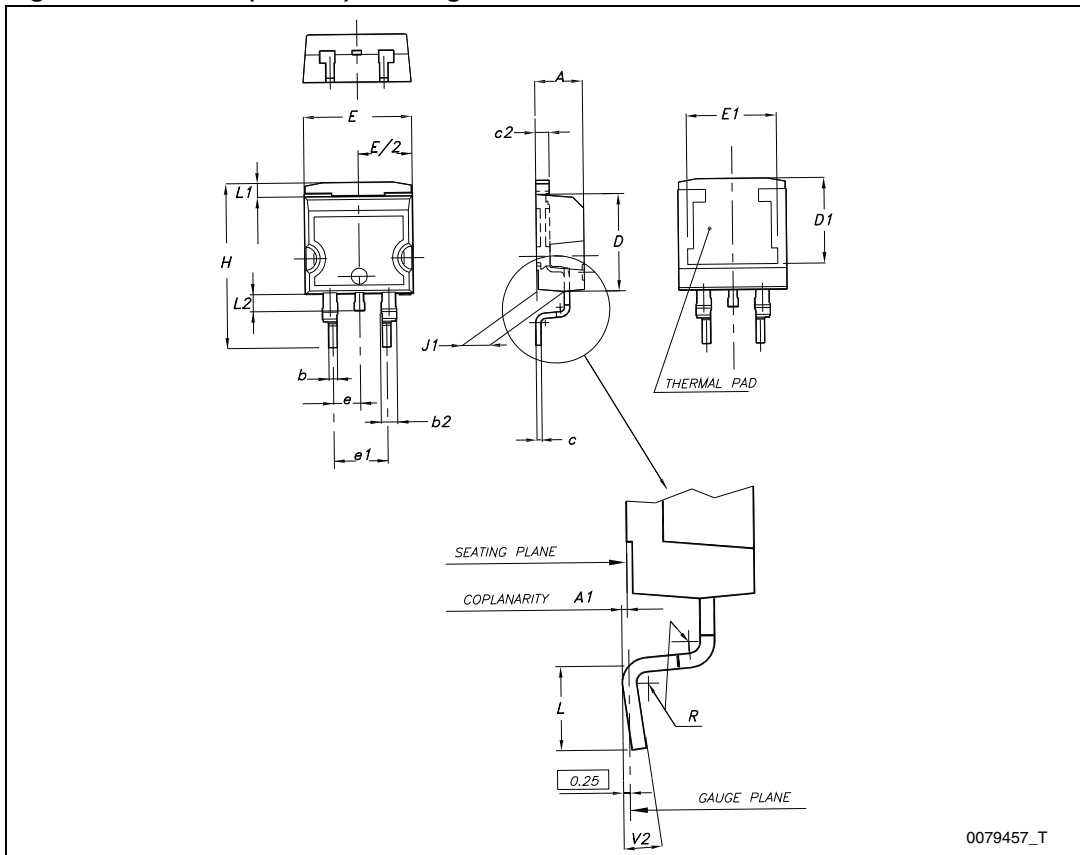
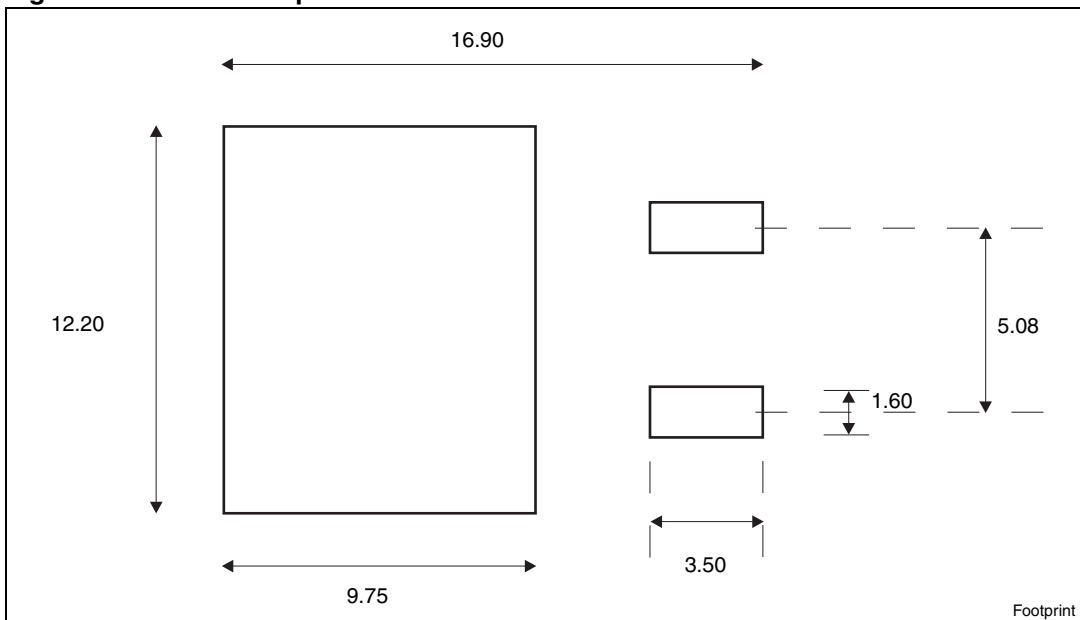

Figure 23. D<sup>2</sup>PAK footprint<sup>(a)</sup>



a. All dimensions are in millimeters

Table 10. TO-220FP mechanical data

| Dim. | mm   |      |      |
|------|------|------|------|
|      | Min. | Typ. | Max. |
| A    | 4.4  |      | 4.6  |
| B    | 2.5  |      | 2.7  |
| D    | 2.5  |      | 2.75 |
| E    | 0.45 |      | 0.7  |
| F    | 0.75 |      | 1    |
| F1   | 1.15 |      | 1.70 |
| F2   | 1.15 |      | 1.70 |
| G    | 4.95 |      | 5.2  |
| G1   | 2.4  |      | 2.7  |
| H    | 10   |      | 10.4 |
| L2   |      | 16   |      |
| L3   | 28.6 |      | 30.6 |
| L4   | 9.8  |      | 10.6 |
| L5   | 2.9  |      | 3.6  |
| L6   | 15.9 |      | 16.4 |
| L7   | 9    |      | 9.3  |
| Dia  | 3    |      | 3.2  |

Figure 24. TO-220FP drawing

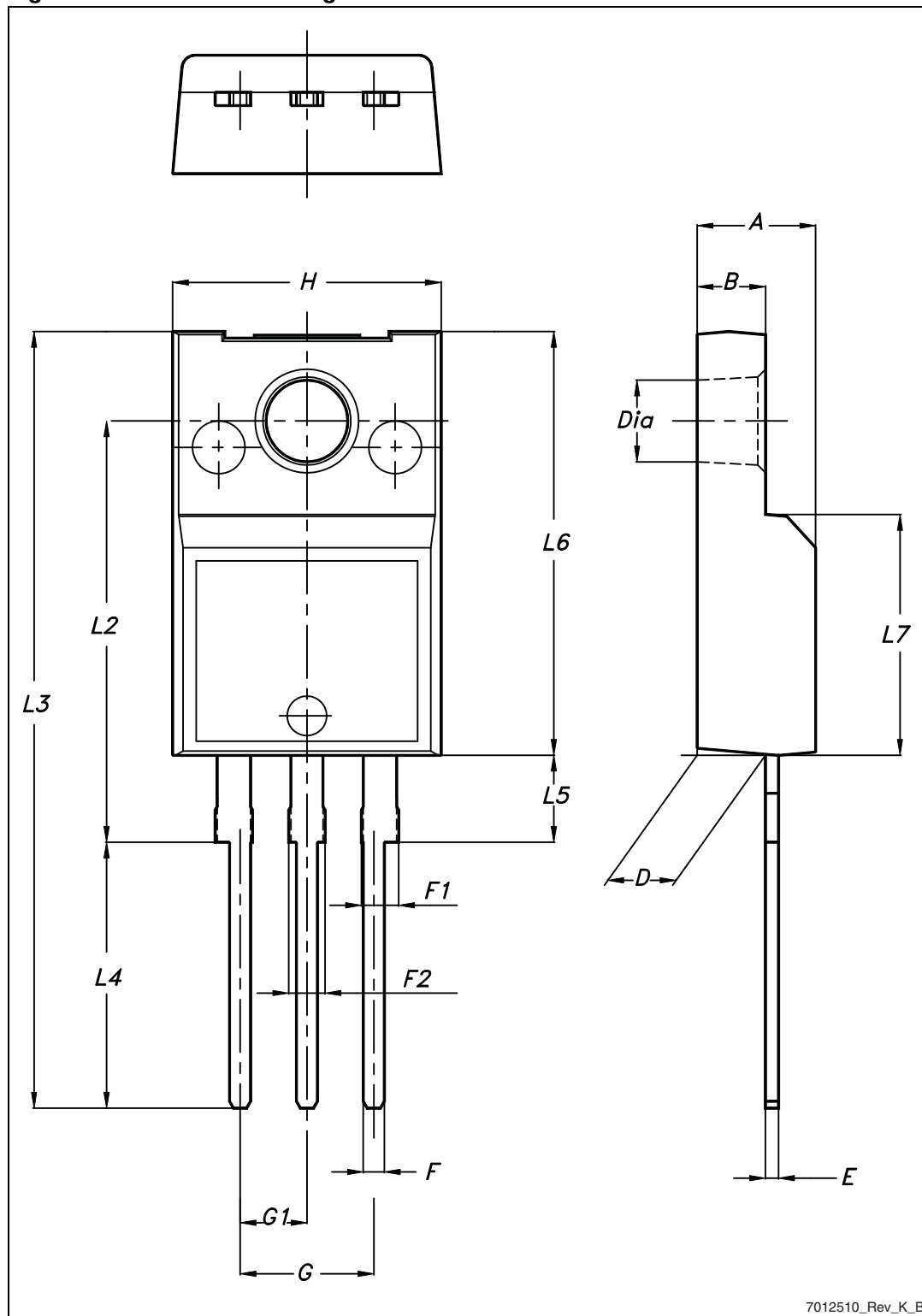

Table 11. TO-220 type A mechanical data

| Dim. | mm    |       |       |
|------|-------|-------|-------|
|      | Min.  | Typ.  | Max.  |
| A    | 4.40  |       | 4.60  |
| b    | 0.61  |       | 0.88  |
| b1   | 1.14  |       | 1.70  |
| c    | 0.48  |       | 0.70  |
| D    | 15.25 |       | 15.75 |
| D1   |       | 1.27  |       |
| E    | 10    |       | 10.40 |
| e    | 2.40  |       | 2.70  |
| e1   | 4.95  |       | 5.15  |
| F    | 1.23  |       | 1.32  |
| H1   | 6.20  |       | 6.60  |
| J1   | 2.40  |       | 2.72  |
| L    | 13    |       | 14    |
| L1   | 3.50  |       | 3.93  |
| L20  |       | 16.40 |       |
| L30  |       | 28.90 |       |
| ØP   | 3.75  |       | 3.85  |
| Q    | 2.65  |       | 2.95  |

Figure 25. TO-220 type A drawing

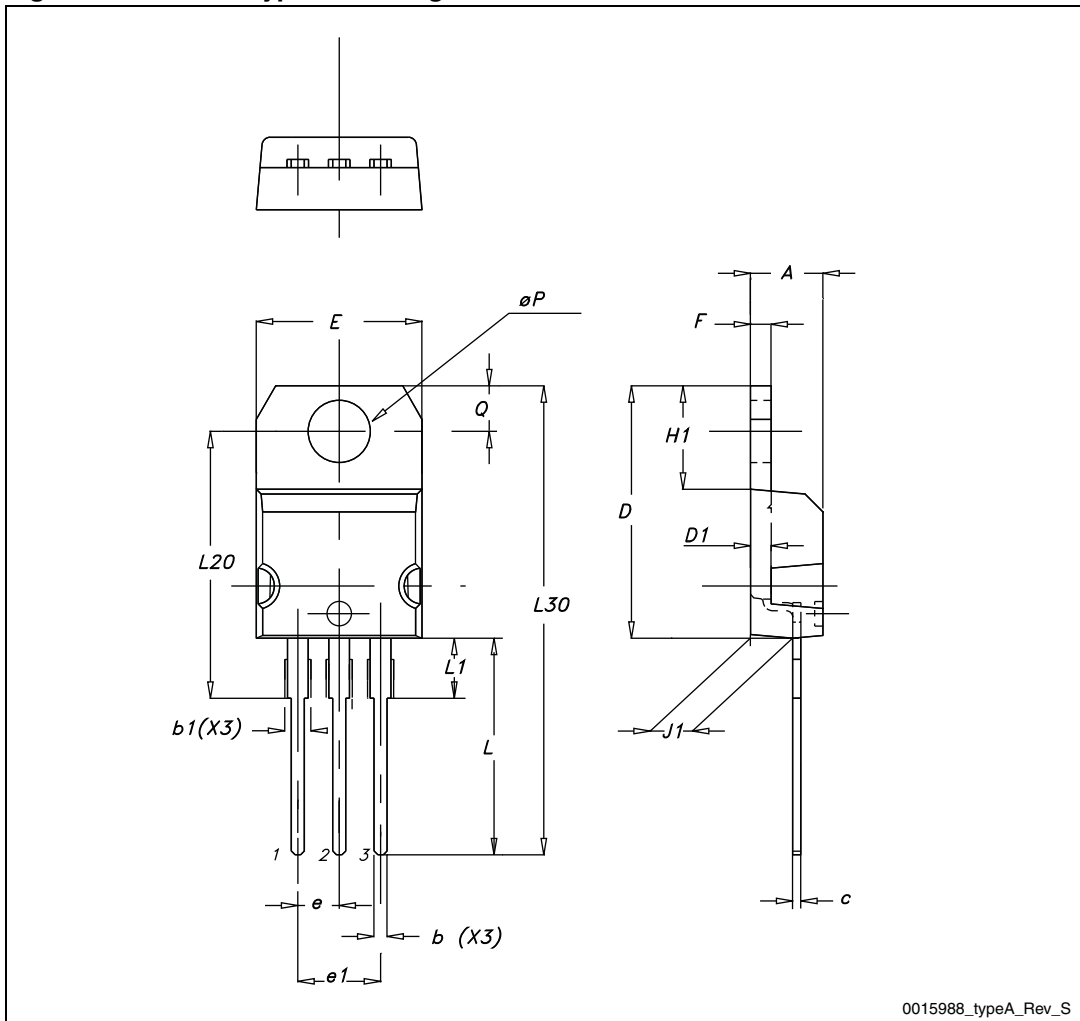
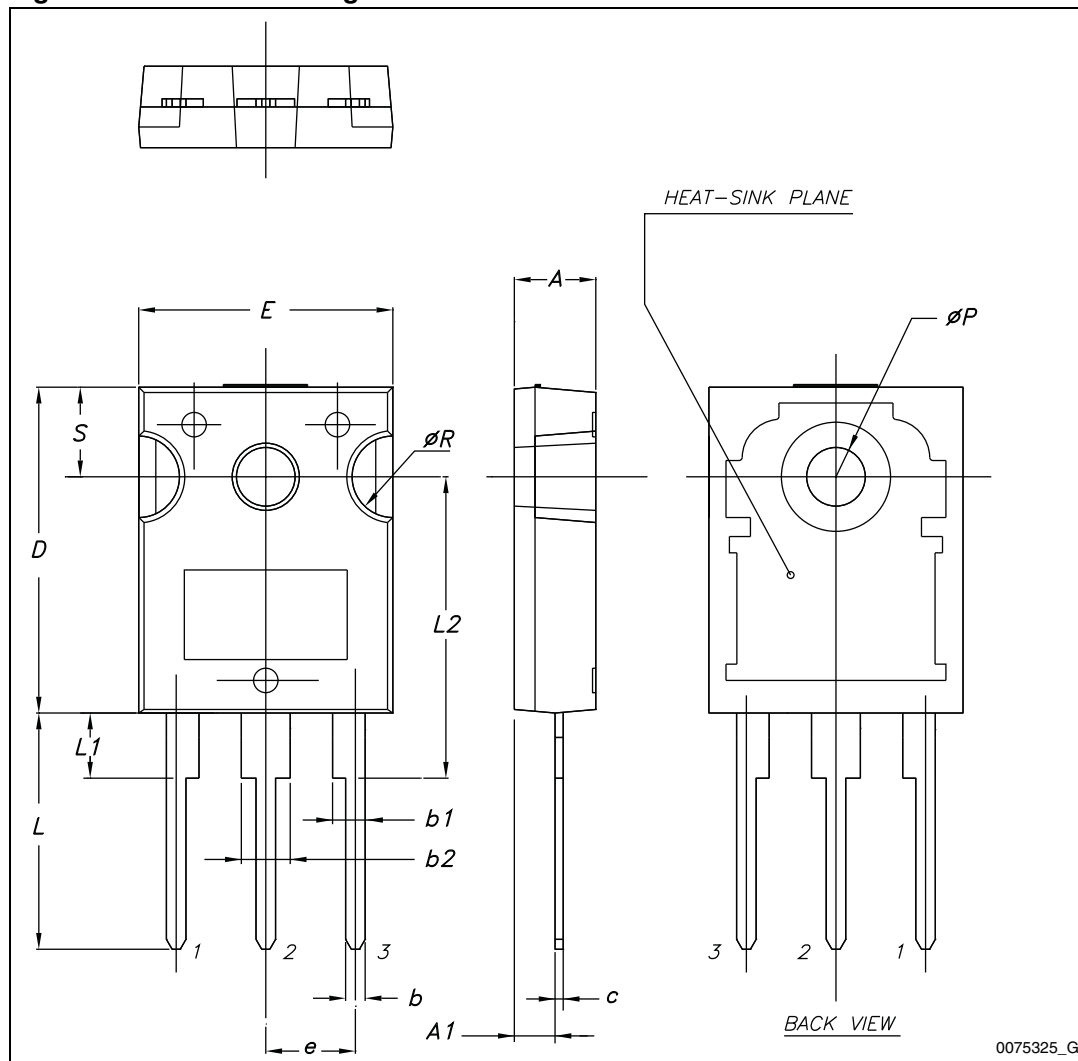

Table 12. TO-247 mechanical data

| Dim. | mm.   |       |       |
|------|-------|-------|-------|
|      | Min.  | Typ.  | Max.  |
| A    | 4.85  |       | 5.15  |
| A1   | 2.20  |       | 2.60  |
| b    | 1.0   |       | 1.40  |
| b1   | 2.0   |       | 2.40  |
| b2   | 3.0   |       | 3.40  |
| c    | 0.40  |       | 0.80  |
| D    | 19.85 |       | 20.15 |
| E    | 15.45 |       | 15.75 |
| e    | 5.30  | 5.45  | 5.60  |
| L    | 14.20 |       | 14.80 |
| L1   | 3.70  |       | 4.30  |
| L2   |       | 18.50 |       |
| ØP   | 3.55  |       | 3.65  |
| ØR   | 4.50  |       | 5.50  |
| S    | 5.30  | 5.50  | 5.70  |



Figure 26. TO-247 drawing



## 5 Packaging mechanical data

Table 13. D<sup>2</sup>PAK (TO-263) tape and reel mechanical data

| Tape |      |      | Reel |          |      |
|------|------|------|------|----------|------|
| Dim. | mm   |      | Dim. | mm       |      |
|      | Min. | Max. |      | Min.     | Max. |
| A0   | 10.5 | 10.7 | A    |          | 330  |
| B0   | 15.7 | 15.9 | B    | 1.5      |      |
| D    | 1.5  | 1.6  | C    | 12.8     | 13.2 |
| D1   | 1.59 | 1.61 | D    | 20.2     |      |
| E    | 1.65 | 1.85 | G    | 24.4     | 26.4 |
| F    | 11.4 | 11.6 | N    | 100      |      |
| K0   | 4.8  | 5.0  | T    |          | 30.4 |
| P0   | 3.9  | 4.1  |      |          |      |
| P1   | 11.9 | 12.1 |      | Base qty | 1000 |
| P2   | 1.9  | 2.1  |      | Bulk qty | 1000 |
| R    | 50   |      |      |          |      |
| T    | 0.25 | 0.35 |      |          |      |
| W    | 23.7 | 24.3 |      |          |      |

Figure 27. Tape

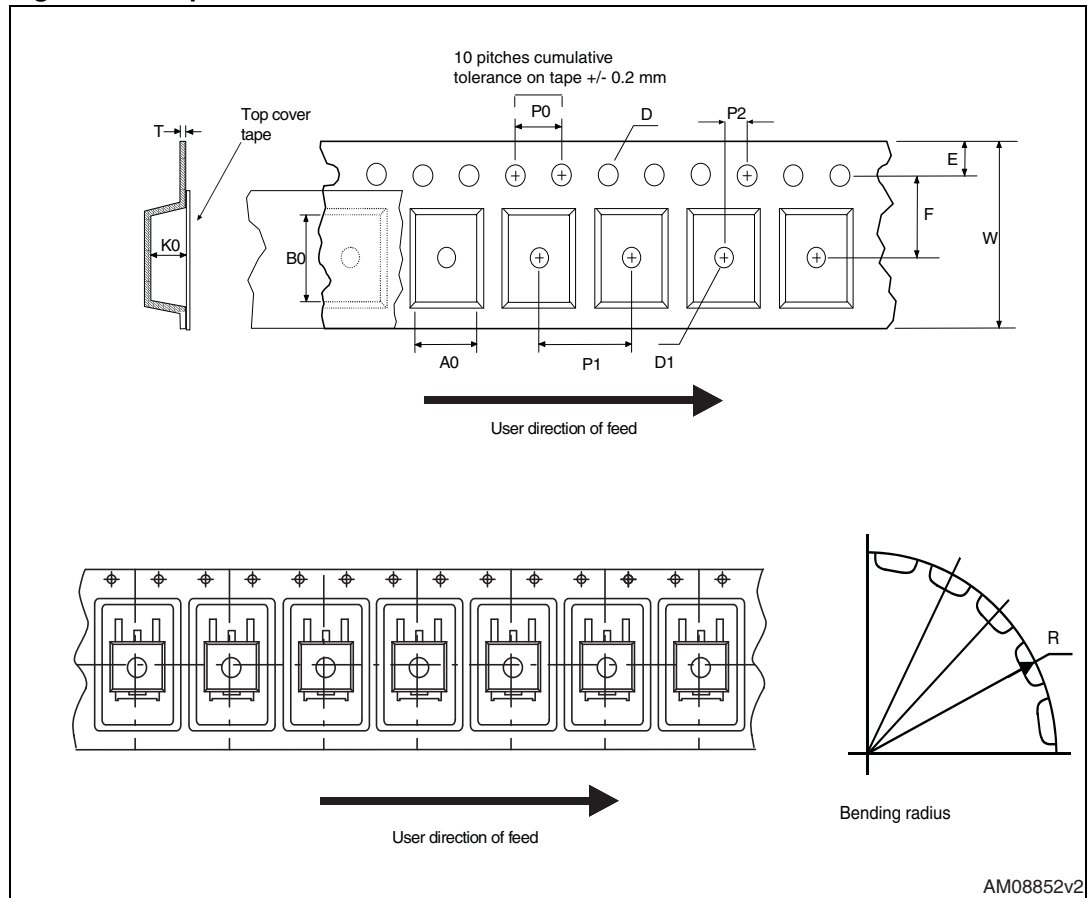

AM08852v2

Figure 28. Reel

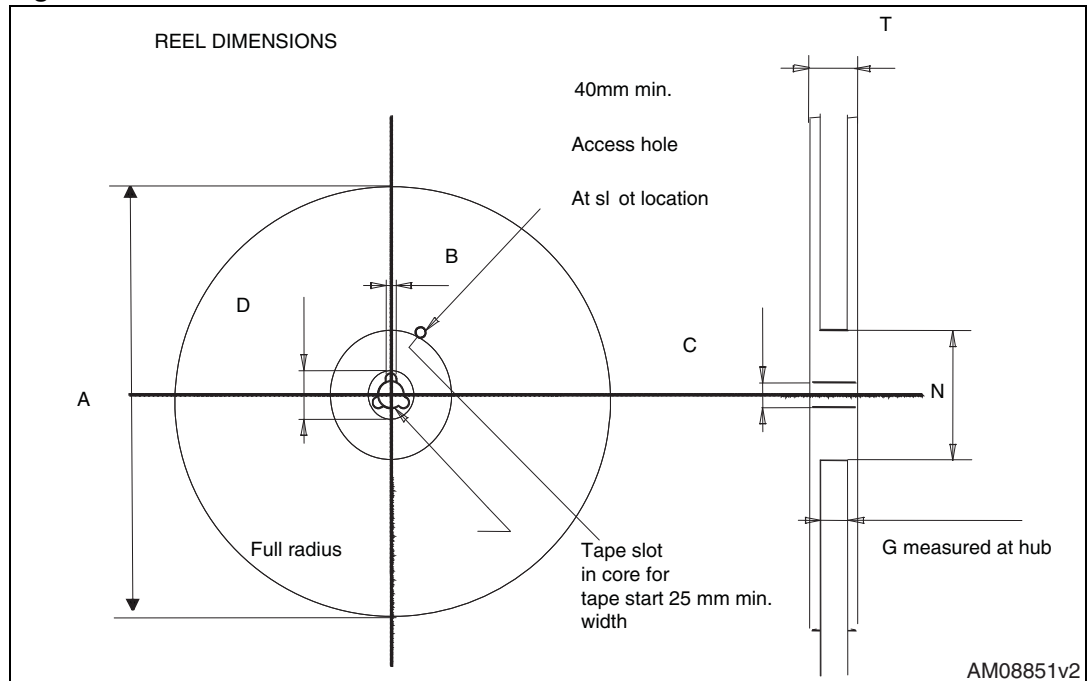

AM08851v2

## 6 Revision history

Table 14. Document revision history

| Date        | Revision | Changes  |
|-------------|----------|--|
| 25-Feb-2009 | 1        | First release.   |
| 07-Apr-2009 | 2        | <a href="#">Section 4: Package mechanical data</a> has been modified.                                  |
| 20-Apr-2009 | 3        | $R_{DS(on)}$ max value has been corrected.   |
| 09-Sep-2009 | 4        | Document status promoted from preliminary data to datasheet.   |
| 25-May-2012 | 5        | <a href="#">Figure 12: Gate charge vs gate-source voltage</a> has been updated.<br>Minor text changes. |

**Please Read Carefully:**

Information in this document is provided solely in connection with ST products. STMicroelectronics NV and its subsidiaries ("ST") reserve the right to make changes, corrections, modifications or improvements, to this document, and the products and services described herein at any time, without notice.

All ST products are sold pursuant to ST's terms and conditions of sale.

Purchasers are solely responsible for the choice, selection and use of the ST products and services described herein, and ST assumes no liability whatsoever relating to the choice, selection or use of the ST products and services described herein.

No license, express or implied, by estoppel or otherwise, to any intellectual property rights is granted under this document. If any part of this document refers to any third party products or services it shall not be deemed a license grant by ST for the use of such third party products or services, or any intellectual property contained therein or considered as a warranty covering the use in any manner whatsoever of such third party products or services or any intellectual property contained therein.

**UNLESS OTHERWISE SET FORTH IN ST'S TERMS AND CONDITIONS OF SALE ST DISCLAIMS ANY EXPRESS OR IMPLIED WARRANTY WITH RESPECT TO THE USE AND/OR SALE OF ST PRODUCTS INCLUDING WITHOUT LIMITATION IMPLIED WARRANTIES OF MERCHANTABILITY, FITNESS FOR A PARTICULAR PURPOSE (AND THEIR EQUIVALENTS UNDER THE LAWS OF ANY JURISDICTION), OR INFRINGEMENT OF ANY PATENT, COPYRIGHT OR OTHER INTELLECTUAL PROPERTY RIGHT.**

**UNLESS EXPRESSLY APPROVED IN WRITING BY TWO AUTHORIZED ST REPRESENTATIVES, ST PRODUCTS ARE NOT RECOMMENDED, AUTHORIZED OR WARRANTED FOR USE IN MILITARY, AIR CRAFT, SPACE, LIFE SAVING, OR LIFE SUSTAINING APPLICATIONS, NOR IN PRODUCTS OR SYSTEMS WHERE FAILURE OR MALFUNCTION MAY RESULT IN PERSONAL INJURY, DEATH, OR SEVERE PROPERTY OR ENVIRONMENTAL DAMAGE. ST PRODUCTS WHICH ARE NOT SPECIFIED AS "AUTOMOTIVE GRADE" MAY ONLY BE USED IN AUTOMOTIVE APPLICATIONS AT USER'S OWN RISK.**

Resale of ST products with provisions different from the statements and/or technical features set forth in this document shall immediately void any warranty granted by ST for the ST product or service described herein and shall not create or extend in any manner whatsoever, any liability of ST.

ST and the ST logo are trademarks or registered trademarks of ST in various countries.

Information in this document supersedes and replaces all information previously supplied.

The ST logo is a registered trademark of STMicroelectronics. All other names are the property of their respective owners.

© 2012 STMicroelectronics - All rights reserved

STMicroelectronics group of companies

Australia - Belgium - Brazil - Canada - China - Czech Republic - Finland - France - Germany - Hong Kong - India - Israel - Italy - Japan - Malaysia - Malta - Morocco - Philippines - Singapore - Spain - Sweden - Switzerland - United Kingdom - United States of America

[www.st.com](http://www.st.com)



# Mouser Electronics

Authorized Distributor

Click to View Pricing, Inventory, Delivery & Lifecycle Information:

[STMicroelectronics:](#)

[STB18NM80](#) [STP18NM80](#) [STW18NM80](#) [STF18NM80](#)