

|              |           |           |           |                           |         |     |      |
|--------------|-----------|-----------|-----------|---------------------------|---------|-----|------|
| WAR NR. —    | LOC<br>A1 | DIST<br>— | REVISIONS |                           |         |     |      |
| PASSEND ZU — |           | P         | LTR       | DESCRIPTION               | DATE    | DWN | APVD |
|              |           | P         |           | REVISED PER ECO-11-005301 | 02MAR11 | RK  | HMR  |

ÄNDERUNGEN, DIE DEM  
TECHNISCHEN FORT-  
SCHRITT DIENEN, BE-  
HALTEN WIR UNS VOR

SIEHE ZEICHNUNG  
826 629 BLATT 3

VON DIESER ZEICHNUNG GIBT ES KEIN ORIGINAL

|             |           |                     |                          |
|-------------|-----------|---------------------|--------------------------|
| BESTELL-NR. | WERKSTOFF | OBERFLÄCHE<br>FARBE | VERWENDET FÜR<br>78-9833 |
|-------------|-----------|---------------------|--------------------------|

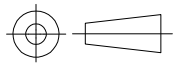
|   |                  |   |  |           |            |               |
|---|------------------|---|--|-----------|------------|---------------|
| DIMENSIONS:<br>mm   | DWN              | — | MATERIAL   | —         | FINISH     | —             |
|   | CHK              | — |  TE Connectivity |           |            |               |
| TOLERANCES UNLESS<br>OTHERWISE SPECIFIED:   | APVD             | — |  |           |            |               |
| 0 PLC ± -   | PRODUCT SPEC     | — | NAME<br>AMPMODU II STIFTLAISTE 90DEG<br>EINREIHIG  |           |            |               |
| 1 PLC ± -   | APPLICATION SPEC | — | SIZE   | CAGE CODE | DRAWING NO | RESTRICTED TO |
| 2 PLC ± -   |                  |   | A4   | 00779     | C-826631   | —             |
| 3 PLC ± -   |                  |   |  |           |            |               |
| 4 PLC ± -   |                  |   |  |           |            |               |
| ANGLES ± -  | WEIGHT           | — |  |           |            |               |
|  |                  |   | CUSTOMER DRAWING   |           | SCALE      | —             |
|   |                  |   |  |           | SHEET      | 1 OF 1        |
|   |                  |   |  |           | REV        | P             |

THIS DRAWING IS UNPUBLISHED. By —  
 ALL RIGHTS RESERVED.

# Mouser Electronics

Authorized Distributor

Click to View Pricing, Inventory, Delivery & Lifecycle Information:

[TE Connectivity:](#)

[826631-8](#)