



SMSC[®]
SUCCESS BY DESIGN

LAN83C185

High Performance Single Chip Low Power 10/100 Ethernet Physical Layer Transceiver (PHY)

PRODUCT FEATURES

Data Brief

- Single Chip Ethernet Phy
- Fully compliant with IEEE 802.3/802.3u standards
- 10BASE-T and 100BASE-TX support
- Supports Auto-negotiation and Parallel Detection
- Automatic Polarity Correction
- Integrated DSP with Adaptive Equalizer
- Baseline Wander (BLW) Correction
- Media Independent Interface (MII)
- 802.3u compliant register functions
- Vendor Specific register functions
- Comprehensive power management features
- General power-down mode
- Energy Detect power-down mode
- Low profile 64-pin TQFP package; lead-free RoHS compliant package also available
- Single +3.3V supply with 5V tolerant I/O
- 0.18 micron technology
- Low power consumption
- Operating Temperature 0° C to 70° C
- Internal +1.8V Regulator

Applications

- LAN on Motherboard
- 10/100 PCMCIA/CardBus Applications
- Embedded Telecom Applications
- Video Record/Playback Systems
- Cable Modems And Set-Top Boxes
- Digital Televisions
- Wireless Access Points

ORDER NUMBERS:

LAN83C185-JD FOR 64-PIN TQFP PACKAGE

LAN83C185-JT FOR 64-PIN TQFP LEAD-FREE ROHS COMPLIANT PACKAGE



80 ARKAY DRIVE, HAUPPAUGE, NY 11788 (631) 435-6000, FAX (631) 273-3123

Copyright © 2008 SMSC or its subsidiaries. All rights reserved.

Circuit diagrams and other information relating to SMSC products are included as a means of illustrating typical applications. Consequently, complete information sufficient for construction purposes is not necessarily given. Although the information has been checked and is believed to be accurate, no responsibility is assumed for inaccuracies. SMSC reserves the right to make changes to specifications and product descriptions at any time without notice. Contact your local SMSC sales office to obtain the latest specifications before placing your product order. The provision of this information does not convey to the purchaser of the described semiconductor devices any licenses under any patent rights or other intellectual property rights of SMSC or others. All sales are expressly conditional on your agreement to the terms and conditions of the most recently dated version of SMSC's standard Terms of Sale Agreement dated before the date of your order (the "Terms of Sale Agreement"). The product may contain design defects or errors known as anomalies which may cause the product's functions to deviate from published specifications. Anomaly sheets are available upon request. SMSC products are not designed, intended, authorized or warranted for use in any life support or other application where product failure could cause or contribute to personal injury or severe property damage. Any and all such uses without prior written approval of an Officer of SMSC and further testing and/or modification will be fully at the risk of the customer. Copies of this document or other SMSC literature, as well as the Terms of Sale Agreement, may be obtained by visiting SMSC's website at <http://www.smisc.com>. SMSC is a registered trademark of Standard Microsystems Corporation ("SMSC"). Product names and company names are the trademarks of their respective holders.

SMSC DISCLAIMS AND EXCLUDES ANY AND ALL WARRANTIES, INCLUDING WITHOUT LIMITATION ANY AND ALL IMPLIED WARRANTIES OF MERCHANTABILITY, FITNESS FOR A PARTICULAR PURPOSE, TITLE, AND AGAINST INFRINGEMENT AND THE LIKE, AND ANY AND ALL WARRANTIES ARISING FROM ANY COURSE OF DEALING OR USAGE OF TRADE. IN NO EVENT SHALL SMSC BE LIABLE FOR ANY DIRECT, INCIDENTAL, INDIRECT, SPECIAL, PUNITIVE, OR CONSEQUENTIAL DAMAGES; OR FOR LOST DATA, PROFITS, SAVINGS OR REVENUES OF ANY KIND; REGARDLESS OF THE FORM OF ACTION, WHETHER BASED ON CONTRACT; TORT; NEGLIGENCE OF SMSC OR OTHERS; STRICT LIABILITY; BREACH OF WARRANTY; OR OTHERWISE; WHETHER OR NOT ANY REMEDY OF BUYER IS HELD TO HAVE FAILED OF ITS ESSENTIAL PURPOSE, AND WHETHER OR NOT SMSC HAS BEEN ADVISED OF THE POSSIBILITY OF SUCH DAMAGES.

General Description

The SMSC LAN83C185 is a low-power, highly integrated analog interface IC for high-performance embedded Ethernet applications. The LAN83C185 requires only a single +3.3V supply.

The LAN83C185 consists of an encoder/decoder, scrambler/descrambler, transmitter with wave-shaping and output driver, twisted-pair receiver with on-chip adaptive equalizer and baseline wander (BLW) correction, clock and data recovery, and Media Independent Interface (MII).

The LAN83C185 is fully compliant with IEEE 802.3/ 802.3u standards and supports both 802.3u-compliant and vendor-specific register functions. It contains a full-duplex 10-BASET/100BASE-TX transceiver and supports 10-Mbps (10BASE-T) operation on Category 3 and Category 5 unshielded twisted-pair cable, and 100-Mbps (100BASE-TX) operation on Category 5 unshielded twisted-pair cable.

Block Diagram

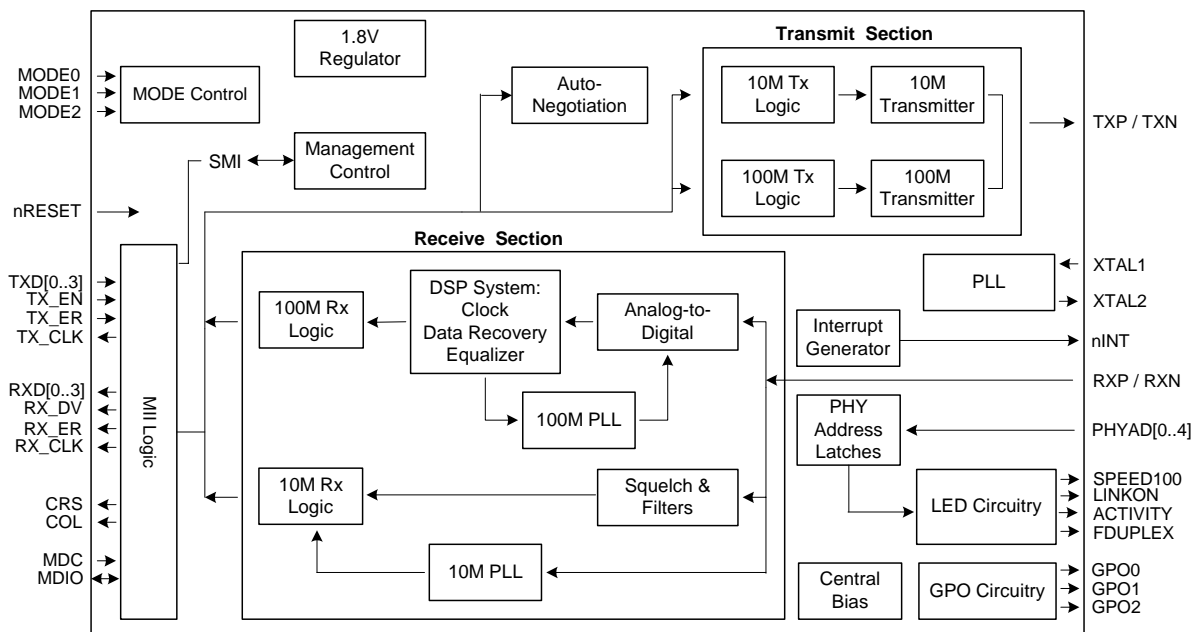

Figure 1 LAN83C185 Architectural Overview

Package Outline

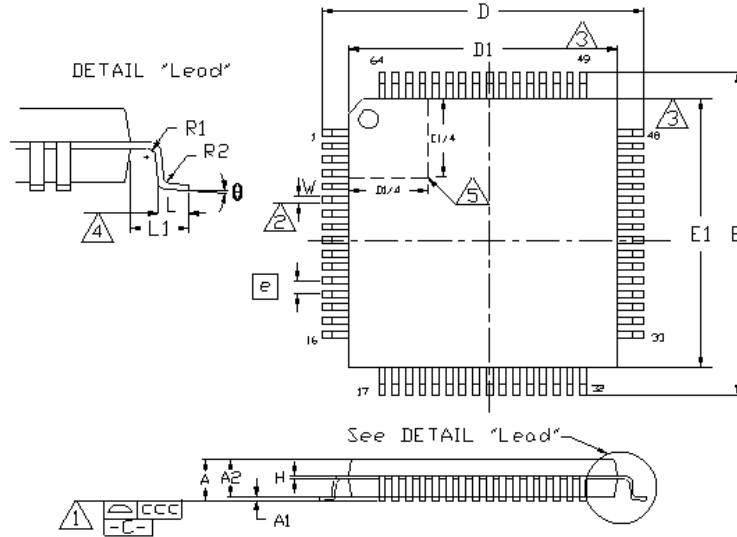

Figure 2 64 Pin TQFP Package Outline, 10X10X1.4 Body, 2 MM Footprint

Table 1 64 Pin TQFP Package Parameters

	MIN	NOMINAL	MAX	REMARKS
A	~	~	1.60	Overall Package Height
A1	0.05	~	0.15	Standoff
A2	1.35	~	1.45	Body Thickness
D	11.80	~	12.20	X Span
D1	9.80	~	10.20	X body Size
E	11.80	~	12.20	Y Span
E1	9.80	~	10.20	Y body Size
H	0.09	~	0.20	Lead Frame Thickness
L	0.45	0.60	0.75	Lead Foot Length
L1	~	1.00	~	Lead Length
e	0.50 Basic			Lead Pitch
θ	0°	~	7°	Lead Foot Angle
W	0.17	0.22	0.27	Lead Width
R	0.08	~	~	Lead Shoulder Radius
R2	0.08	~	0.20	Lead Foot Radius
ccc	~	~	0.08	Coplanarity

Notes:

1. Controlling Unit: millimeter.
2. Tolerance on the true position of the leads is ± 0.04 mm maximum.
3. Package body dimensions D1 and E1 do not include the mold protrusion. Maximum mold protrusion is 0.25 mm per side.
4. Dimension for foot length L measured at the gauge plane 0.25 mm above the seating plane.
5. Details of pin 1 identifier are optional but must be located within the zone indicated.

Mouser Electronics

Authorized Distributor

Click to View Pricing, Inventory, Delivery & Lifecycle Information:

[Microchip:](#)

[LAN83C185-JT](#)