

Basic Building-block Controllers That Mount Directly to Panels for Easier Maintenance

- Easy maintenance with building-block Relay Units.
- Easy identification of operating status with LED operation indicator.
- Lineup includes models for tropical regions and for high temperatures. Achieve stable detection even in high-temperature environments.

 Refer to *Safety Precautions for Floatless Level Controllers.*



Model Number Structure

61F-□□
1 2

1. Control Application

- G: Automatic water supply and drainage
- G1: Automatic water supply with idling prevention or water shortage alarm
- G2: Automatic water supply and drainage with abnormal water increase alarm
- G3: Automatic water supply and drainage with full tank and water shortage alarm
- G4: Automatic water supply with water level indicator for water supply tank and water receiving tank and prevention of idling due to water shortage
- I: Liquid level indication and alarm (no two-wire models)

2. Type

- Blank: General-purpose
- L 2KM: Long-distance (for 2 km)
- L 4KM: Long-distance (for 4 km)
- H: High-sensitivity
- D: Low-sensitivity
- R: Two-wire
- T: High-temperature

Position of LED indicator

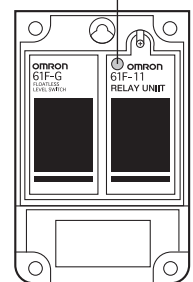

Ordering Information

Type	Set contents	General-purpose	Long-distance, 2 km	Long-distance, 4 km	High-sensitivity
		Model	Model	Model	Model
Application G	61F-G Base x 1 61F-11□ Units x 1	61F-G	61F-GL 2KM	61F-GL 4KM	61F-GH
Application G1	61F-G1 Base x 1 61F-11□ Units x 2	61F-G1	61F-G1L 2KM	61F-G1L 4KM	61F-G1H
Application G2	61F-G2 Base x 1 61F-11□ Units x 2	61F-G2	61F-G2L 2KM	61F-G2L 4KM	61F-G2H
Application G3	61F-G3 Base x 1 61F-11□ Units x 3	61F-G3	61F-G3L 2KM	61F-G3L 4KM	61F-G3H
Application G4	61F-G4 Base x 1 61F-11□ Units x 5 MK3P Relay x 1	61F-G4	61F-G4L 2KM	61F-G4L 4KM	61F-G4H
Application I	61F-I Base x 1 61F-11□ Units x 2	61F-I	61F-IL 2KM	61F-IL 4KM	61F-IH
Relay Unit	61F-11□ Units x 1	61F-11	61F-11L 2KM	61F-11L 4KM	61F-11H

Type	Set contents	Low-sensitivity	2-wire	Tropical environments	High-temperature
		Model	Model	Model	Model
Application G	61F-G Base x 1 61F-11□ Units x 1	61F-GD	61F-GR	61F-G-TDL	61F-GT
Application G1	61F-G1 Base x 1 61F-11□ Units x 2	61F-G1D	61F-G1R	61F-G1-TDL	61F-G1T
Application G2	61F-G2 Base x 1 61F-11□ Units x 2	61F-G2D	61F-G2R	61F-G2-TDL	61F-G2T
Application G3	61F-G3 Base x 1 61F-11□ Units x 3	61F-G3D	61F-G3R	61F-G3-TDL	61F-G3T
Application G4	61F-G4 Base x 1 61F-11□ Units x 5 MK3P Relay x 1	61F-G4D	61F-G4R	61F-G4-TDL	61F-G4T
Application I	61F-I Base x 1 61F-11□ Units x 2	61F-ID	---	61F-I-TDL	61F-IT
Relay Unit	61F-11□ Units x 1	61F-11D	61F-11R	---	61F-11T

Note: 1. When ordering, specify the desired operating voltage at the end of the model number.

Example: 61F-G [110/220 VAC]

_____ Desired supply voltage

2. If you order with a standard model number, the corresponding Relay Units are also delivered as part of a set.
If you order the 61F-G, one 61F-11 Relay Unit is included in the set.

Specifications

Standard Models

Specifications

Items	General-purpose Controller 61F-□ (TDL) (see note 1 and 2)	High-temperature Controller 61F-□T (see note 1)	Long-distance Controllers 61F-□L 2KM (for 2 km) 61F-□L 4KM (for 4 km) (see note 1)	High-sensitivity Controllers 61F-□H (see note 1)	Low-sensitivity Controller 61F-□D (see note 1)	Two-wire Controller 61F-□R (see note 1)
Controlling materials and operating conditions	For control of ordinary purified water or sewage water	For control of ordinary purified water or sewage water in cases where the ambient temperature is high.	For control of ordinary purified water in cases where the distance between sewage pumps and water tanks or between receiver tanks and supply tanks is long or where remote control is required.	For control of liquids with high specific resistance such as distilled water	For control of liquids with low specific resistance such as salt water, sewage water, acid chemicals, alkali chemicals	For control of ordinary purified water or sewage water used in combination with Two-wire Electrode Holder (incorporating a resistor of 6.8 kΩ) It is possible to wire with less than one wiring against general 61F's wiring.
Supply voltage	100, 110, 120, 200, 220 or 240 VAC; 50/60 Hz					
Operating voltage range	85% to 110% of rated voltage					
InterElectrode voltage	8 VAC			24 VAC	8 VAC	
InterElectrode current	Approx. 1 mA AC max.					
Power consumption	61F-G□: 3.5 VA max.; G1F-G1□, G1F-G2□, or G1F-I□: 5.5 VA max.; G1F-G3□: 7.5 VA max.; G1F-G4□: 14.5 VA max.					
InterElectrode operate resistance	0 to approx. 4 kΩ	0 to approx. 5 kΩ	0 to approx. 1.8 kΩ (for 2 km) 0 to approx. 0.7 kΩ (for 4 km)	Approx. 15 kΩ to 70 kΩ (see note 5)	0 to approx. 1.8 kΩ	0 to approx. 1.1 kΩ
InterElectrode release resistance	Approx. 15 k to ∞ Ω	Approx. 15 k to ∞ Ω	4 k to ∞ Ω (for 2 km) 2.5 k to ∞ Ω (for 4 km)	Approx. 300 k to ∞ Ω	Approx. 5 k to ∞ Ω	Approx. 15 k to ∞ Ω
Cable length (see note 3)	1 km max.	600 m max.	2 km max. 4 km max.	50 m max.	1 km max.	800 m max.
Control output	2 A, 220 VAC (Inductive load: $\cos\phi = 0.4$) 5 A, 220 VAC (Resistive load)					
Ambient temperature	Operating: -10 to 55°C (-10 to 70°C for 61F-□T)					
Ambient humidity	Operating: 45% to 85% RH					
Insulation resistance (see note 4)	100 MΩ min. (at 500 VDC)					
Dielectric strength (see note 4)	2000 VAC, 50/60 Hz for 1 min.					
Life expectancy	Electrical: 500,000 operations min. Mechanical: 5,000,000 operations min.					
Weight	61F-G□: Approx. 380 g, G1F-G1□, G1F-G2□, or G1F-I□: Approx. 750 g; G1F-G3□: Approx. 930 g; G1F-G4□: Approx. 1,710 g					

Note: 1. The □ in the model name represents G, G1, G2, G3, G4, and I.

2. The suffix "TDL" attached to the model name represents models designed for tropical regions (storage humidity of 45% to 90%). For details, refer to *Safety Precautions for Floatless Level Controllers*.

3. The length when using completely-insulated, 600-V, 3-conductor (0.75 mm²) cabtire cables. Usable cable lengths will become shorter as the cable diameter or number of conductors becomes larger. For details, refer to *Safety Precautions for Floatless Level Controllers*.

4. The insulation resistance and dielectric strength indicate values between power terminals and Electrode terminals, between power terminals and contact terminals, and between Electrode terminals and contact terminals.

5. Possible to use with 15 kΩ or less, however, this may cause reset failure.

6. High-sensitivity Controllers use advanced operation.

When the power supply voltage is applied, if there are some liquids between the electrodes (ground and operation electrodes), the internal relay will not operate.

When the power supply voltage is applied, if there are no liquids between the electrodes (ground and operation electrodes), the internal relay will operate.

• Advanced Operation

With advanced operation, the internal relay operates as soon as control power is supplied to the G1F and is reset when current flows between the poles. Wiring is the same as for models with sequential operation.

Internal Circuit Diagrams

The schematic diagrams shown below typify the internal connections of the various 61F models. The designations Ta, Tb, and Tc (sometimes referred to collectively as "U") may occur more than once in a product, however, the "a" terminal is always an NO contact, a "b" terminal is an NC contact, and the "c" terminal is the common terminal.

61F-G

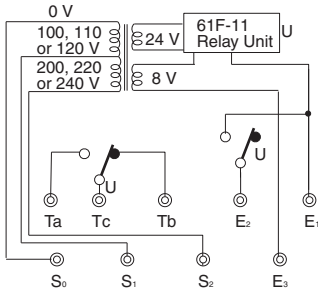

61F-GT

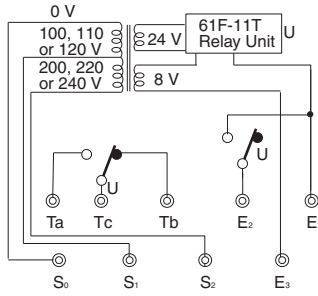

61F-GL

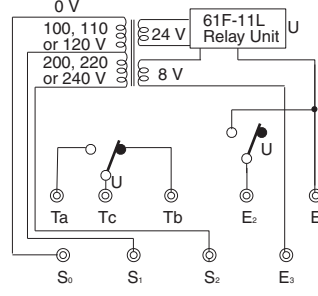

61F-GH
(See note.)

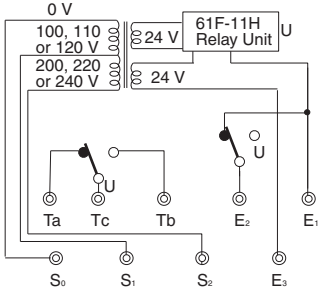

61F-GD

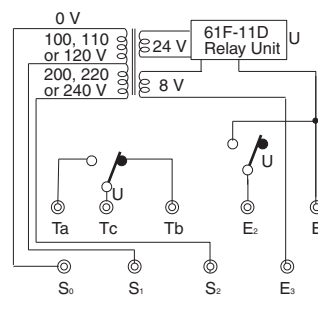

61F-GR

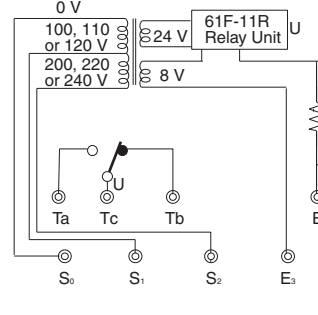

Note: The 61F11H relay deenergizes when there is water present across the Electrodes, whereas the 61F relay energizes when there is water present across the Electrodes.
 Also, the terminal connections of those Controllers provided with LED indicators differ from those which have no indicators.

61F-11 Relay Units

Item	61F-11	61F-11T	61F-11L	61F-11H	61F-11D	61F-11R
Interchangeable with general-purpose model (61F-11)	---	Provided	Provided	Not provided	Provided	Not provided
Color of band on name plate	---	Red	Yellow	Blue	Black	Green

61F-11

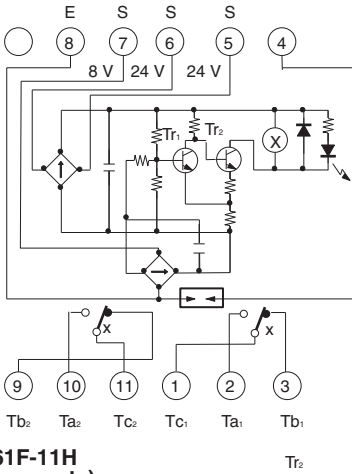

61F-11T

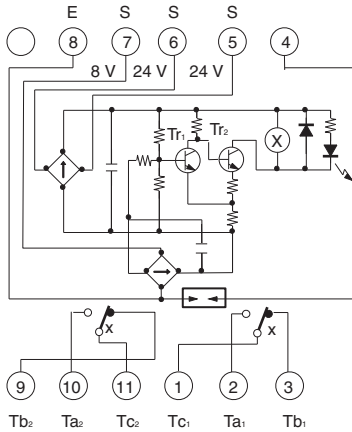

61F-11L

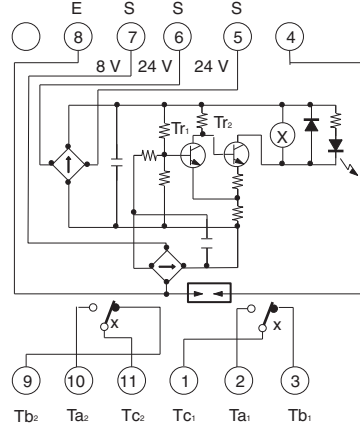

61F-11H
(see note)

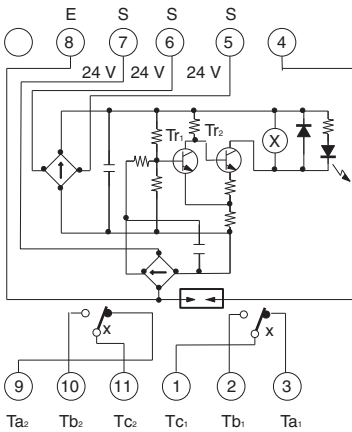

61F-11D

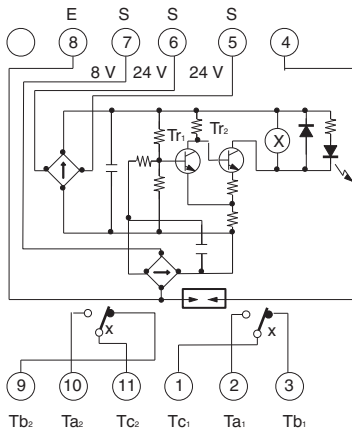

61F-11R

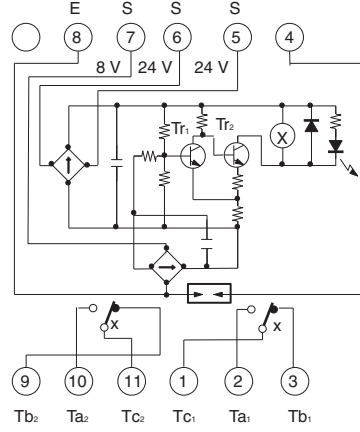

Connections

Automatic Water Supply and Drainage Control

Basic Type

61F-G

Dimensions:
page 14

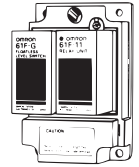

Automatic Water Supply Control	Automatic Drainage Control
<p>Connections</p> <p>Note: Be sure to ground the common Electrode (the longest Electrode).</p> <ul style="list-style-type: none"> • Connect Tb to the contactor's coil terminal. • Power Supply Connections (for models with 110/220-V power) 110 VAC: Connect S₀ and S₁. 220 VAC: Connect S₀ and S₂. 	<p>Connections</p> <p>Note: Be sure to ground the common Electrode (the longest Electrode).</p> <ul style="list-style-type: none"> • Connect Ta to the contactor's coil terminal. (Do not connect Tb.) • Power Supply Connections (for models with 110/220-V power) 110 VAC: Connect S₀ and S₁. 220 VAC: Connect S₀ and S₂.
<p>Principles of Operation</p> <p style="text-align: right;">Relay Unit Location</p> <p>The pump stops (indicator ON) when the water level reaches E₁ and starts (indicator OFF) when the water level drops below E₂.</p>	<p>Principles of Operation</p> <p style="text-align: right;">Relay Unit Location</p> <p>The pump starts (indicator ON) when the water level reaches E₁ and stops (indicator OFF) when the water level drops below E₂.</p>

Automatic Water Supply Control with Pump Idling Prevention and Automatic Water Supply Control with Abnormal Water Shortage Alarm

Basic Type

61F-G1

Dimensions:
page 14

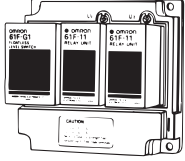

<p>Automatic Water Supply Control with Pump Idling Prevention</p> <p>Connections</p> <p>Note: Be sure to ground the common Electrode (the longest Electrode).</p> <ul style="list-style-type: none"> • Power Supply Connections 110 VAC: Connect S₀ and S₁. 220 VAC: Connect S₀ and S₂. • Insert a pushbutton switch (NO) between E₁' and E₃, as shown by the dotted lines above. • Do not press the pushbutton if the low-water alarm sounds and the pump stops during normal operation (U₁ indicator ON, water below E₂'). <p>Test Operation/Recovering from Power Interruptions</p> <p>If the supply water level is below E₁' when starting operation or when recovering from a power interruption, press the pushbutton to momentarily close the circuit (U₁ indicator turns ON) to start the pump.</p> <p>Principles of Operation</p> <ul style="list-style-type: none"> • The pump starts (U₂ indicator OFF) when the water level drops below E₂ and stops (U₂ indicator ON) when the water level reaches E₁. • When the level of the water supply source drops below E₂', the pump stops (U₁ indicator OFF). Pump idling is prevented and the alarm sounds. 	<p>Automatic Water Supply Control with Abnormal Water Shortage Alarm</p> <p>Connections</p> <p>Note: Be sure to ground the common Electrode (the longest Electrode).</p> <ul style="list-style-type: none"> • Power Supply Connections 110 VAC: Connect S₀ and S₁. 220 VAC: Connect S₀ and S₂. • Insert a pushbutton switch (NO) between E₃ and E₄. • If the pump stops when the pushbutton switch is released, press it again. <p>Test Operation/Recovering from Power Interruptions</p> <p>If the supply water level is below E₄ when starting operation or when recovering from a power interruption, press the pushbutton to momentarily close the circuit (U₁ indicator turns ON) to start the pump.</p> <p>Principles of Operation</p> <ul style="list-style-type: none"> • The pump stops (U₂ indicator ON) when the water level reaches E₁ and starts (U₂ indicator OFF) when the water level drops below E₂. • If the water level drops below E₄ for any reason, the pump stops (U₁ indicator OFF) and the alarm sounds.
--	---

Automatic Drainage Control and Water Supply with Abnormal Water Increase Alarm

Basic Type

61F-G2

Dimensions:
page 14

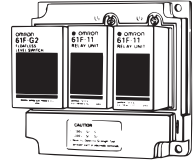

Automatic Water Supply with Overfull Tank Alarm	Automatic Drainage Control with Overfull Tank Alarm
<p style="text-align: center;">Connections</p> <p>Note: Be sure to ground the common Electrode (the longest Electrode).</p> <ul style="list-style-type: none"> • Connect Tb1 to the power supply. • Power Supply Connections 110 VAC: Connect S₀ and S₁. 220 VAC: Connect S₀ and S₂. 	<p style="text-align: center;">Connections</p> <p>Note: Be sure to ground the common Electrode (the longest Electrode).</p> <ul style="list-style-type: none"> • Connect Ta1 to the power supply. • Power Supply Connections 110 VAC: Connect S₀ and S₁. 220 VAC: Connect S₀ and S₂.
<p style="text-align: center;">Principles of Operation</p> <div style="display: flex; justify-content: space-between;"> <div style="width: 45%;"> </div> <div style="width: 45%; text-align: center;"> <p>Relay Unit Location</p> </div> </div> <ul style="list-style-type: none"> • The pump starts (U₂ indicator OFF) when the water level drops below E₂ and starts (U₂ indicator ON) when the water level reaches E₁. • If the water level reaches E₄ for any reason, the alarm sounds (U₁ indicator ON). 	<p style="text-align: center;">Principles of Operation</p> <div style="display: flex; justify-content: space-between;"> <div style="width: 45%;"> </div> <div style="width: 45%; text-align: center;"> <p>Relay Unit Location</p> </div> </div> <ul style="list-style-type: none"> • The pump starts (U₂ indicator OFF) when the water level reaches E₁ and stops (U₂ indicator ON) when the water level drops below E₂. • If the water level reaches E₄ for any reason, the alarm sounds (U₁ indicator ON).

Automatic Water Supply and Drainage Control with Abnormal Water Increase and Water Shortage Alarms

Basic Type

61F-G3

Dimensions:
page 14

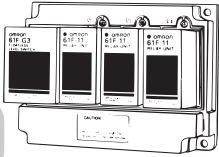

Automatic Water Supply with Abnormal Water Increase and Water Shortage Alarms

Connections

Note: Be sure to ground the common Electrode (the longest Electrode).

- Connect Tb to the contactor's coil terminal.
- Power Supply Connections
110 VAC: Connect S₀ and S₁.
220 VAC: Connect S₀ and S₂.

Automatic Drainage Control with Abnormal Water Increase and Water Shortage Alarms

Connections

Note: Be sure to ground the common Electrode (the longest Electrode).

- Connect Ta to the contactor's coil terminal. (Do not connect Tb.)
- Power Supply Connections
110 VAC: Connect S₀ and S₁.
220 VAC: Connect S₀ and S₂.

Principles of Operation

Relay Unit Locations

- The pump stops (U₂ indicator ON) when the water level reaches E₂ and starts (U₂ indicator OFF) when the water level drops below E₃.
- If the water level rises to E₁ for any reason, the upper-limit indicator turns ON and the alarm sounds (U₁ indicator ON). If the water level drops below E₄ for any reason, the lower-limit indicator turns ON and the alarm sounds (U₃ indicator OFF).

Principles of Operation

Relay Unit Locations

- The pump starts (U₂ indicator ON) when the water level reaches E₂ and stops (U₂ indicator OFF) when the water level drops below E₃.
- If the water level rises to E₁ for any reason, the upper-limit indicator turns ON and the alarm sounds (U₁ indicator ON). If the water level drops below E₄ for any reason, the lower-limit indicator turns ON and the alarm sounds (U₃ indicator OFF).

Automatic Water Supply Control with Water Source Level Indication, Prevention of Pump Idling Due to Water Shortage, and Indication of Water Level in Tank

Basic Type

61F-G4

Dimensions:
page 14

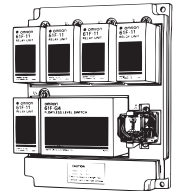

Automatic Water Supply Control with Water Source Level Indication, Prevention of Pump Idling Due to Water Shortage, and Indication of Water Level in Tank

Connections

- Power Supply Connections
110 VAC: Connect S₀ and S₁.
220 VAC: Connect S₀ and S₂.
- Insert a pushbutton switch (NO) between E₂ and E₈, as shown by the dotted lines above.
- Do not press the pushbutton if the low-water alarm sounds and the pump stops during normal operation (water below E₃).

Test Operation/Recovering from Power Interruptions

If the supply water level is below E₂ when starting operation or when recovering from a power interruption (U₂ indicator OFF), press the pushbutton to momentarily close the circuit to start the pump.

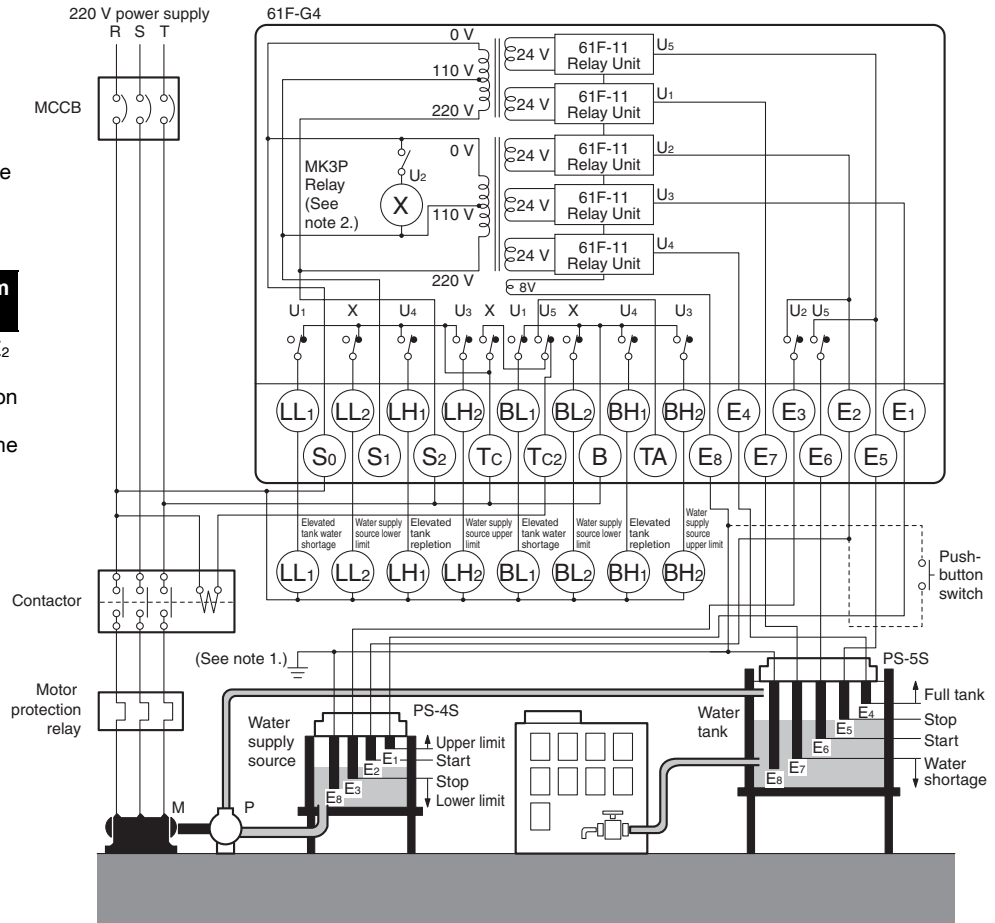

Note: Be sure to ground the common Electrode (the longest Electrode).

Principles of Operation

- Insert four Electrodes in the water supply source and five Electrodes in the elevated water tank.
- The lower-limit indicator for the water supply source remains ON while the water source level is below E₃ (U₂ indicator OFF).
- When the water level rises to E₂, the lower-limit indicator turns OFF (U₂ indicator ON) and the pump is ready for operation.
- The upper-limit indicator in the water supply source lights when the water level reaches E₁ (U₃ indicator ON).
- The water-shortage indicator for the elevated tank remains ON while the water level in the elevated tank is below E₇. The indicator turns OFF (U₁ indicator ON) when the water level rises to E₇.
- The pump stops (U₅ indicator ON) when the water level reaches E₅ and starts (U₅ indicator OFF) when the water level drops below E₆.
- If the water level reaches E₄ for any reason, the abnormal water increase indicator for the elevated tank turns ON (U₄ indicator ON).

Relay Unit Location

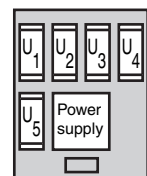

■ Connection with Three-phase Four-line Circuit

When supplying power from N-phase to the Controller in three-phase four-line circuit, refer to the following diagrams.
Line voltage (R-S, S-T, or R-T): 380 or 415 VAC
Phase voltage (N-R, N-S, or N-T): 220 or 240 VAC

61F-G□, 220 or 240 VAC

Water Supply

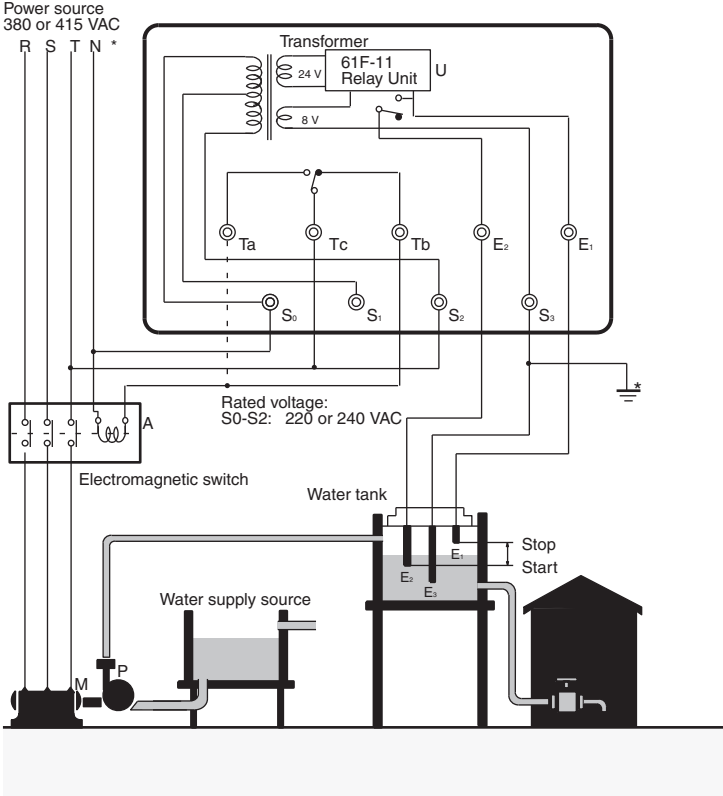

Note: Be sure to ground terminal E3.

Liquid Level Indication and Alarm

Basic Type

61F-I

Dimensions:
page 14

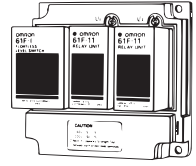

Liquid Level Indication and Alarm

Connections

- Power Supply Connections
110 VAC: Connect S₀ and S₁.
220 VAC: Connect S₀ and S₂.

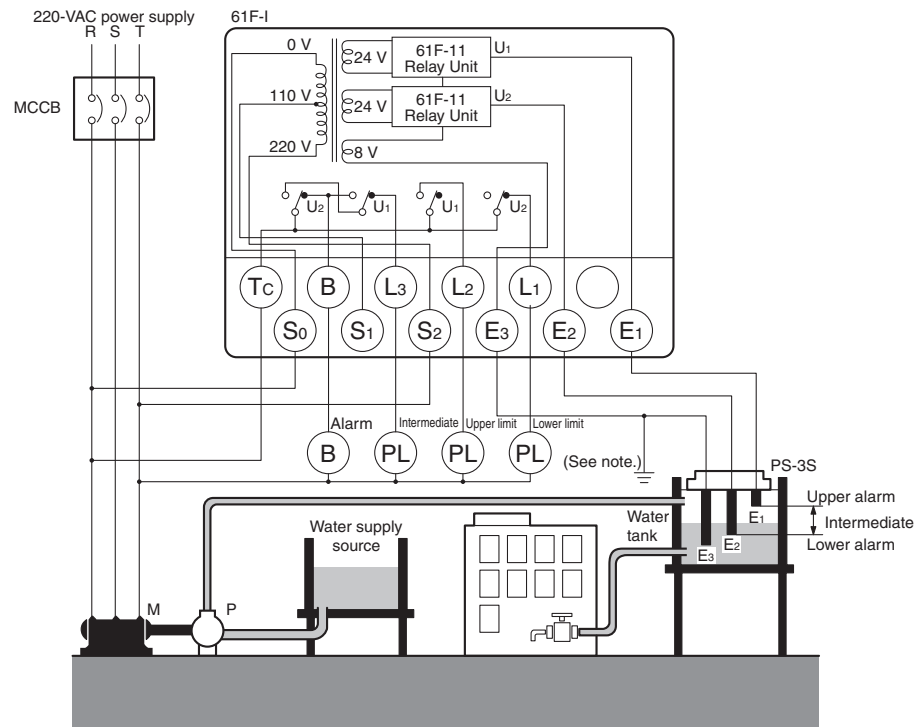

Note: Be sure to ground the common Electrode (the longest Electrode).

Principles of Operation

- When the water level drops below E₂, the lower-limit indicator turns ON and the alarm sounds (U₂ indicator OFF).
- When the water level reaches E₂, the alarm turns OFF and the intermediate indicator turns ON (U₂ indicator ON).
- When the water level rises to E₁, the upper-limit indicator turns ON and the alarm sounds (U₁ indicator ON).

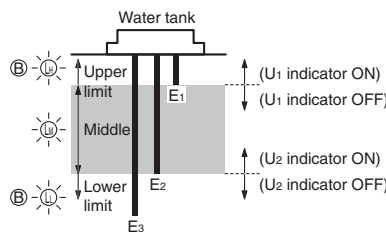

Relay Unit Location



Two-Wire Connections

Automatic Water Supply and Drainage Control

Basic Type
61F-GR

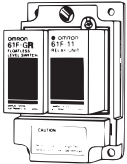

Automatic Water Supply Control	Automatic Drainage Control
<p style="text-align: center;">Connections</p> <p>Note: Be sure to ground the common Electrode (the longest Electrode).</p> <ul style="list-style-type: none"> • Connect Tb to the contactor's coil terminal. • Power Supply Connections 110 VAC: Connect S₀ and S₁. 220 VAC: Connect S₀ and S₂. • With 2-wire connections, only two wires are required between the 61F-GR and Electrode Holder, but three wires are required for the Electrodes. • The Electrode Holder must be specified for 2-wire connections. (Resistance R is built into Electrode Holders for 2-Wire Connections.) • The Relay Unit must also be specified for 2-wire connections. 	<p style="text-align: center;">Connections</p> <p>Note: Be sure to ground the common Electrode (the longest Electrode).</p> <ul style="list-style-type: none"> • Connect Ta to the contactor's coil terminal. (Do not connect Tb.) • Power Supply Connections (for models with 110/220-V power) 110 VAC: Connect S₀ and S₁. 220 VAC: Connect S₀ and S₂. • With 2-wire connections, only two wires are required between the 61F-GR and Electrode Holder, but three wires are required for the Electrodes. • The Electrode Holder must be specified for 2-wire connections. (Resistance R is built into Electrode Holders for 2-Wire Connections.) • The Relay Unit must also be specified for 2-wire connections.
<p style="text-align: center;">Principles of Operation</p> <p>The pump stops (U indicator ON) when the water level reaches E₁ and starts (U indicator OFF) when the water level drops below E₂.</p>	<p style="text-align: center;">Principles of Operation</p> <p>The pump starts (U indicator ON) when the water level reaches E₁ and stops (U indicator OFF) when the water level drops below E₂.</p>

Dimensions

Note: All units are in millimeters unless otherwise indicated.

Standard Models

61F-G

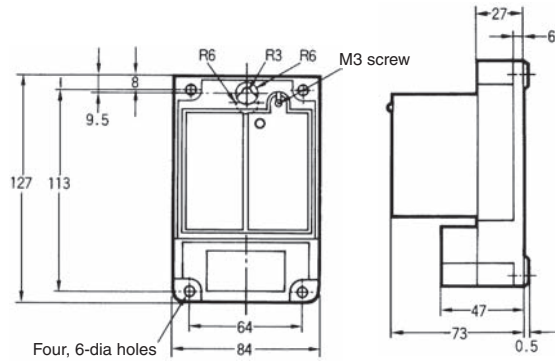
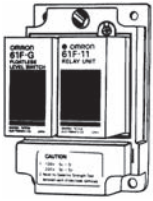

Mounting Holes

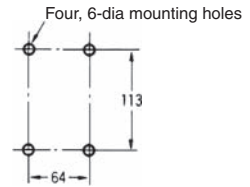

61F-G1 61F-G2 61F-I

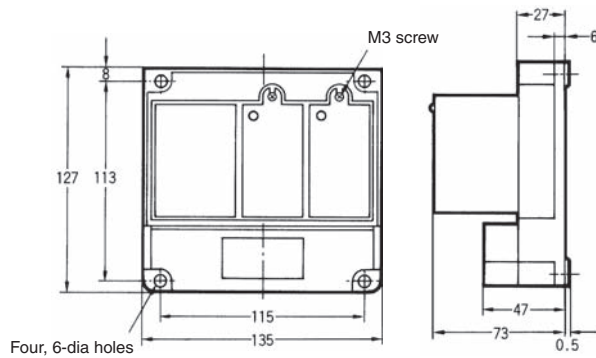
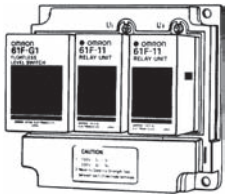

Mounting Holes

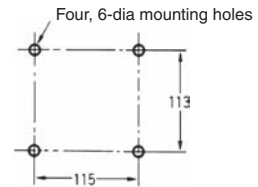

61F-G3

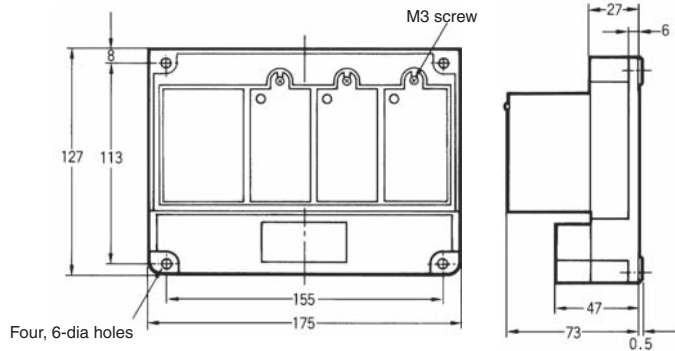
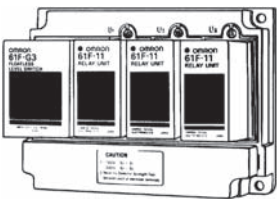

Mounting Holes

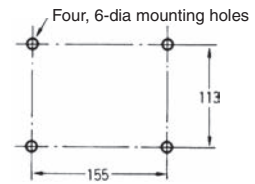

61F-G4

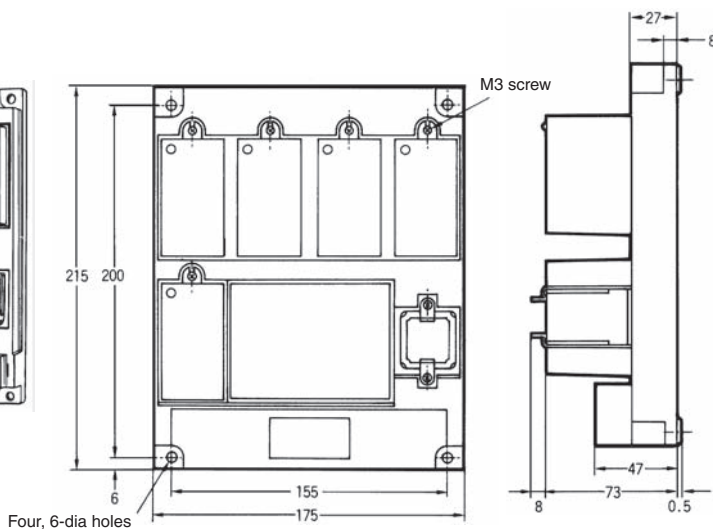
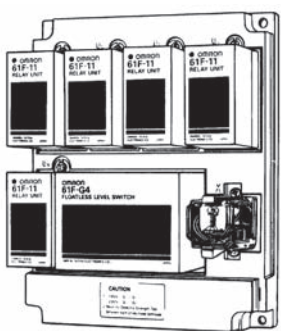

Mounting Holes

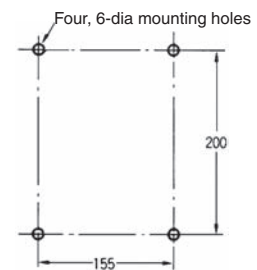

ALL DIMENSIONS SHOWN ARE IN MILLIMETERS.

To convert millimeters into inches, multiply by 0.03937. To convert grams into ounces, multiply by 0.03527.

In the interest of product improvement, specifications are subject to change without notice.

Terms and Conditions Agreement

Read and understand this catalog.

Please read and understand this catalog before purchasing the products. Please consult your OMRON representative if you have any questions or comments.

Warranties.

(a) Exclusive Warranty. Omron's exclusive warranty is that the Products will be free from defects in materials and workmanship for a period of twelve months from the date of sale by Omron (or such other period expressed in writing by Omron). Omron disclaims all other warranties, express or implied.

(b) Limitations. OMRON MAKES NO WARRANTY OR REPRESENTATION, EXPRESS OR IMPLIED, ABOUT NON-INFRINGEMENT, MERCHANTABILITY OR FITNESS FOR A PARTICULAR PURPOSE OF THE PRODUCTS. BUYER ACKNOWLEDGES THAT IT ALONE HAS DETERMINED THAT THE PRODUCTS WILL SUITABLY MEET THE REQUIREMENTS OF THEIR INTENDED USE.

Omron further disclaims all warranties and responsibility of any type for claims or expenses based on infringement by the Products or otherwise of any intellectual property right. (c) Buyer Remedy. Omron's sole obligation hereunder shall be, at Omron's election, to (i) replace (in the form originally shipped with Buyer responsible for labor charges for removal or replacement thereof) the non-complying Product, (ii) repair the non-complying Product, or (iii) repay or credit Buyer an amount equal to the purchase price of the non-complying Product; provided that in no event shall Omron be responsible for warranty, repair, indemnity or any other claims or expenses regarding the Products unless Omron's analysis confirms that the Products were properly handled, stored, installed and maintained and not subject to contamination, abuse, misuse or inappropriate modification. Return of any Products by Buyer must be approved in writing by Omron before shipment. Omron Companies shall not be liable for the suitability or unsuitability or the results from the use of Products in combination with any electrical or electronic components, circuits, system assemblies or any other materials or substances or environments. Any advice, recommendations or information given orally or in writing, are not to be construed as an amendment or addition to the above warranty.

See <http://www.omron.com/global/> or contact your Omron representative for published information.

Limitation on Liability; Etc.

OMRON COMPANIES SHALL NOT BE LIABLE FOR SPECIAL, INDIRECT, INCIDENTAL, OR CONSEQUENTIAL DAMAGES, LOSS OF PROFITS OR PRODUCTION OR COMMERCIAL LOSS IN ANY WAY CONNECTED WITH THE PRODUCTS, WHETHER SUCH CLAIM IS BASED IN CONTRACT, WARRANTY, NEGLIGENCE OR STRICT LIABILITY.

Further, in no event shall liability of Omron Companies exceed the individual price of the Product on which liability is asserted.

Suitability of Use.

Omron Companies shall not be responsible for conformity with any standards, codes or regulations which apply to the combination of the Product in the Buyer's application or use of the Product. At Buyer's request, Omron will provide applicable third party certification documents identifying ratings and limitations of use which apply to the Product. This information by itself is not sufficient for a complete determination of the suitability of the Product in combination with the end product, machine, system, or other application or use. Buyer shall be solely responsible for determining appropriateness of the particular Product with respect to Buyer's application, product or system. Buyer shall take application responsibility in all cases.

NEVER USE THE PRODUCT FOR AN APPLICATION INVOLVING SERIOUS RISK TO LIFE OR PROPERTY OR IN LARGE QUANTITIES WITHOUT ENSURING THAT THE SYSTEM AS A WHOLE HAS BEEN DESIGNED TO ADDRESS THE RISKS, AND THAT THE OMRON PRODUCT(S) IS PROPERLY RATED AND INSTALLED FOR THE INTENDED USE WITHIN THE OVERALL EQUIPMENT OR SYSTEM.

Programmable Products.

Omron Companies shall not be responsible for the user's programming of a programmable Product, or any consequence thereof.

Performance Data.

Data presented in Omron Company websites, catalogs and other materials is provided as a guide for the user in determining suitability and does not constitute a warranty. It may represent the result of Omron's test conditions, and the user must correlate it to actual application requirements. Actual performance is subject to the Omron's Warranty and Limitations of Liability.

Change in Specifications.

Product specifications and accessories may be changed at any time based on improvements and other reasons. It is our practice to change part numbers when published ratings or features are changed, or when significant construction changes are made. However, some specifications of the Product may be changed without any notice. When in doubt, special part numbers may be assigned to fix or establish key specifications for your application. Please consult with your Omron's representative at any time to confirm actual specifications of purchased Product.

Errors and Omissions.

Information presented by Omron Companies has been checked and is believed to be accurate; however, no responsibility is assumed for clerical, typographical or proofreading errors or omissions.

2015.9

In the interest of product improvement, specifications are subject to change without notice.

OMRON Corporation
Industrial Automation Company

<http://www.ia.omron.com/>

(c)Copyright OMRON Corporation 2015 All Right Reserved.

Mouser Electronics

Authorized Distributor

Click to View Pricing, Inventory, Delivery & Lifecycle Information:

Omron:

[61F-11](#) [61F-G2-AC100/200](#) [61F-G3-AC110/220](#) [61F-G3-AC120/240](#) [61F-G4H-AC120/240](#)