

CORE (28A3039-000)

FERRITE CORE DIMENSIONS (SPEC): mm [in]

A	20.46 [.806]	+	REF.
B	10.23 [.403]	+	"
C	10.00 [.394]	+	"
D	10.23 [.403]	+	"

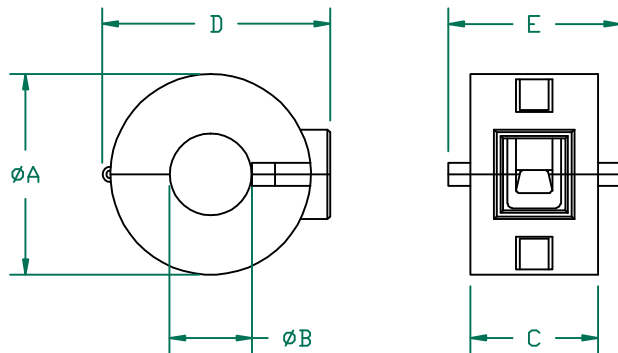

CASE DIMENSIONS (SPEC): mm [in]

A	24.55 [.967]	+	0.45 [.018]
B	10.20 [.402]	+	0.50 [.020]
C	13.60 [.535]	+	0.40 [.016]
D	28.50 [1.122]	+	0.60 [.024]
E	19.90 [.783]	+	0.70 [.028]

**UNCONTROLLED DOCUMENT**

IMPEDANCE (Z)			
Frequency	25 MHz	100 MHz	300 MHz
Nominal (REF)	55 Ω	130 Ω	250 Ω
Minimum	- Ω	104 Ω	- Ω

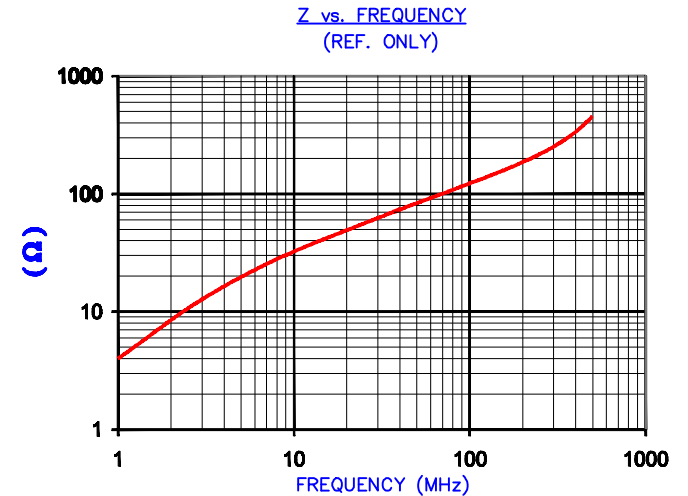

AGILENT E4991A Impedance/Material Analyzer  
HP 16092A-Test Fixture, REF 3399

NOTES:

1. CASE UL FLAMMABILITY RATING: 94 V-0
2. ASSEMBLED PART #: 28A3039-0A2
3. FOR CORE DIMENSIONS SEE STEWARD P/N 28A3039-000.
4. CASE COLOR: -0A2 BLACK CASE.

DIMENSIONS ARE IN mm [INCHES].				This print is the property of Laird Tech. and is loaned in confidence subject to return upon request and with the understanding that no copies shall be made without the written consent of Laird Tech. All rights to design or invention are reserved.				
H	UPDATE CASE TOLERANCES UPDATE COMPANY LOGO	05/08/08	TMB	PROJECT/PART NUMBER: <b>28A3039-0A2</b>		REV	PART TYPE:	DRAWN BY:
G	UPDATE Z SPECS AND COMPANY LOGO	07/03/07	JRK			H	FERRITE SNAP-ON	TMB
F	RE-ACTIVATE PRINT, REM NOTE 4, UPDATE Z SPECS, ADD REF NUMBER	7/21/04	JRK	DATE: 06/27/01		SCALE:	MATERIAL:	
E	CHANGE P/N FROM -0A* TO -0A2 REVISE NOTES 2, 4, & 5	08/15/03	TMB			NTS	NiZn Ferrite	
D	CHANGE PRINT FORMAT CHANGE Z SPECS AND ADD CURVE REVISE NOTE 3,4,& 5	06/26/03	TMB	CAD # 28A3039-0A2-H		TOOL #	-	
REV	DESCRIPTION	DATE	INT					

# Mouser Electronics

Authorized Distributor

Click to View Pricing, Inventory, Delivery & Lifecycle Information:

Laird:

[28A3039-0A2](#)