

features

- Very low resistance, high precision reliability
- Utilization of thick film
- Low T.C.R. achieved (± 100 ppm/ $^{\circ}$ C)
- Products with lead-free terminations meet EU RoHS requirements. EU RoHS regulation is not intended for Pb-glass contained in electrode, resistor element and glass.

current sense



dimensions and construction

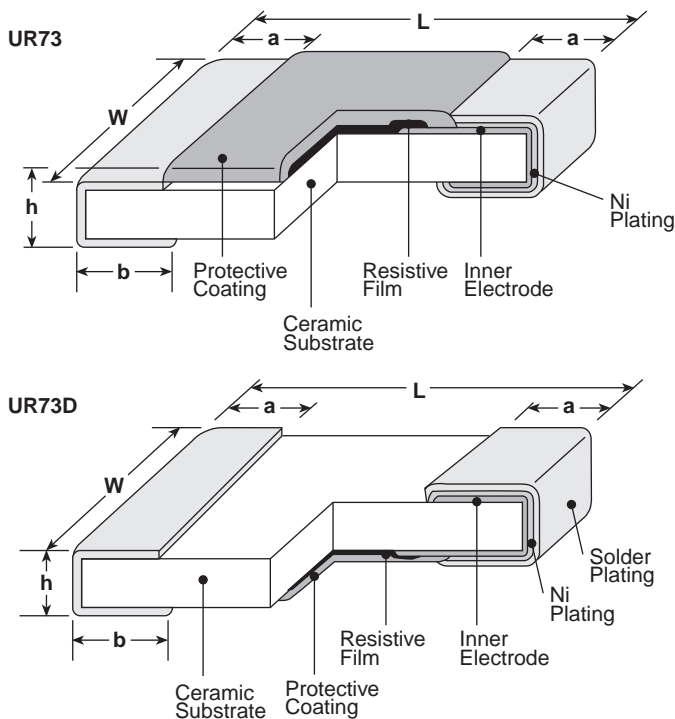

Size Code	Resistance Range (Ω)	Dimensions inches (mm)				
		L	W	h	a	b
D1E (0402)	24m ~ 100m	$.039^{+.004}_{-.002}$ (1.0 ^{+0.1} _{-0.05})	$.020^{+.004}_{-.002}$ (0.5 ^{+0.1} _{-0.05})	$.016 \pm .002$ (0.4 \pm 0.05)	$.010 \pm .004$ (0.25 \pm 0.1)	$.012 \pm .004$ (0.3 \pm 0.1)
D1J (0603)	10m ~ 27m	$.063 \pm .008$ (1.6 \pm 0.2)	$.031^{+.005}_{-.004}$ (0.8 ^{+0.15} _{-0.1})	$.02 \pm .004$ (0.5 \pm 0.1)	$.014 \pm .004$ (0.35 \pm 0.1)	$.022 \pm .004$ (0.55 \pm 0.1)
	30m ~ 100m					$.014 \pm .004$ (0.35 \pm 0.1)
D2A (0805)	10m ~ 16m	$.079 \pm .008$ (2.0 \pm 0.2)	$.049 \pm .008$ (1.25 \pm 0.2)	$.022 \pm .004$ (0.55 \pm 0.1)	$.016 \pm .008$ (0.4 \pm 0.2)	$.024 \pm .008$ (0.6 \pm 0.2)
	18m ~ 30m					$.02 \pm .008$ (0.5 \pm 0.2)
2A (0805)	33m ~ 100m	$.079 \pm .008$ (2.0 \pm 0.2)	$.049 \pm .008$ (1.25 \pm 0.2)	$.02 \pm .004$ (0.55 \pm 0.1)	$.016 \pm .008$ (0.4 \pm 0.2)	$.012^{+.008}_{-.004}$ (0.3 ^{+0.2} _{-0.1})
D2B (1206)	10m ~ 16m	$.126 \pm .008$ (3.2 \pm 0.2)	$.063 \pm .008$ (1.6 \pm 0.2)	$.024 \pm .004$ (0.6 \pm 0.1)	$.020 \pm .008$ (0.5 \pm 0.2)	$.039 \pm .008$ (1.0 \pm 0.2)
	18m ~ 27m					$.031 \pm .008$ (0.8 \pm 0.2)
2B (1206)	30m ~ 100m	$.126 \pm .008$ (3.2 \pm 0.2)	$.063 \pm .008$ (1.6 \pm 0.2)	$.024 \pm .004$ (0.6 \pm 0.1)	$.020 \pm .012$ (0.5 \pm 0.3)	$.016^{+.008}_{-.004}$ (0.4 ^{+0.2} _{-0.1})
D2H (2010)	10m ~ 30m	$.197 \pm .008$ (5.0 \pm 0.2)	$.098 \pm .008$ (2.5 \pm 0.2)	$.026 \pm .004$ (0.65 \pm 0.1)	$.026 \pm .012$ (0.65 \pm 0.3)	$.063 \pm .012$ (1.6 \pm 0.3)
	33m ~ 100m					$.026 \pm .012$ (0.65 \pm 0.3)
D3A (2512)	10m ~ 30m	$.248 \pm .008$ (6.3 \pm 0.2)	$.122 \pm .008$ (3.1 \pm 0.2)	$.024 \pm .004$ (0.6 \pm 0.1)	$.031 \pm .012$ (0.8 \pm 0.3)	$.079 \pm .012$ (2.0 \pm 0.3)
	33m ~ 100m					$.031 \pm .012$ (0.8 \pm 0.3)

ordering information

UR73	2A	T	TD	R100	F
Type	Power Rating	Termination Material	Packaging	Nominal Resistance	Tolerance
UR73 UR73D	1E: 0.125W 1J: 0.25W 2A: 0.33W 2B: 0.5W 2H: 0.75W 3A: 1W	T: Sn	TP: 2mm pitch punch paper (1E) TD: 7" punched paper tape (1J, 2A, 2B) TE: 7" embossed plastic (2H, 3A)	"R" indicates decimal on values = 100m Ω Ex: R100 = 100m Ω "L" indicates decimal on values <100m Ω Ex: 10L0 = 10m Ω	F: $\pm 1\%$

For further information on packaging, please refer to Appendix A.

applications and ratings

Part Designation	Power Rating	Rated Ambient Temperature	Rated Terminal Part Temp.	T.C.R. (ppm/°C) Max.	Resistance Range	Operating Temperature Range
					F (±1%) E-24, 25mΩ, 50mΩ	
UR73D1E	1/8W (.125W)	70°C	—	±100	30mΩ - 100mΩ	-55°C to +125°C
UR73D1J	1/4W (.25W)	70°C	80°C	±500	24mΩ - 27mΩ	
				±100	47mΩ - 100mΩ	
				±200	30mΩ - 43mΩ	
UR73D2A	1/3W (.33W)	70°C	90°C	±300	10mΩ - 27mΩ	
				±250	10mΩ - 30mΩ	
UR732A	1/3W (.33W)	70°C	100°C	±100	47mΩ - 100mΩ	
				±250	33mΩ - 43mΩ	
UR73D2B	1/2W (.5W)	70°C	85°C	±200	10mΩ - 27mΩ	
UR732B	1/2W (.5W)	70°C	85°C	±100	47mΩ - 100mΩ	
				±200	30mΩ - 43mΩ	
UR73D2H	3/4W (.75W)	70°C	90°C	±250	10mΩ - 30mΩ	
				±100	33mΩ - 100mΩ	
UR73D3A	1W (1W)	70°C	95°C	±250	10mΩ - 30mΩ	
				±100	33mΩ - 100mΩ	

Rated voltage = $\sqrt{P \cdot R}$

If any questions should arise whether to use the "Rated Ambient Temperature" or the "Rated Terminal Part Temperature," please give priority to the "Rated Terminal Part Temperature." Prior to use and for more details refer to "Introduction of the derating curves on the terminal part temperature" in the beginning of the catalog.

environmental applications

Derating Curve

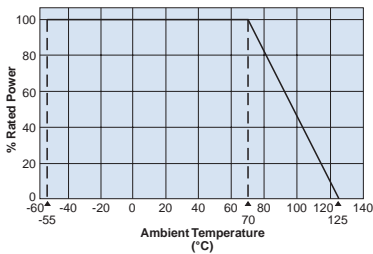

For resistors operated at an ambient temperature of 70°C or above, a power rating shall be derated in accordance with the above derating curve.

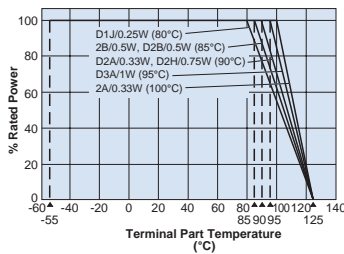

For resistors operated at a terminal part temperature of described for each size or above, a power rating shall be derated in accordance with the derating curve.

Please refer to "Introduction of the derating curve based on the terminal part temperature" in the beginning of our catalog prior use.

Surface Temperature Rise

UR73 2A, 2B 33mΩ UR73D 1J, 2A, 2B, 2H, 3A 10mΩ
UR73D 1E 24mΩ

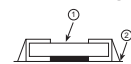
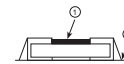
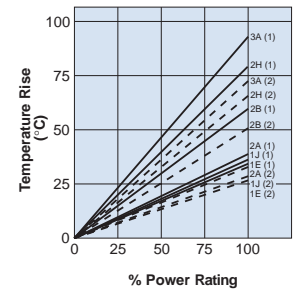
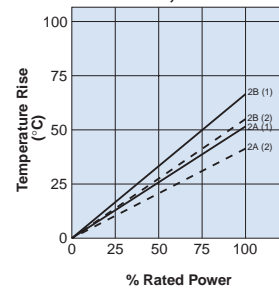

Regarding the temperature rise, the value of the temperature varies per conditions and board for use since the temperature is measured under our measuring conditions.

Performance Characteristics

Parameter	Requirement $\Delta R \pm(\%+0.005\Omega)$		Test Method
	Limit	Typical	
Resistance	Within specified tolerance	—	25°C
T.C.R.	Within specified T.C.R.	—	+25°C/+55°C and +25°C/+125°C
Overload (Short time)	±2%	±0.5%	Rated voltage x 2.5 for 5 seconds
Resistance to Solder Heat	±1%	±0.3%	260°C ± 5°C, 10 ± 1 second
Rapid Change of Temperature	±1%	±0.5%	-55°C (30 minutes), +125°C (30 minutes), 100 cycles
Moisture Resistance	±2%	±1%	40°C ± 2°C, 90%~95%RH, 1000 hours, 1.5 hr ON, 0.5 hr OFF cycle
Endurance at 70°C	±2%	±1%	70°C ± 2°C, 1000 hours, 1.5 hr ON, 0.5 hr OFF cycle
High Temperature Exposure	±1%	±0.3%	+125°C, 1000 hours

Specifications given herein may be changed at any time without prior notice. Please confirm technical specifications before you order and/or use.

10/25/18