

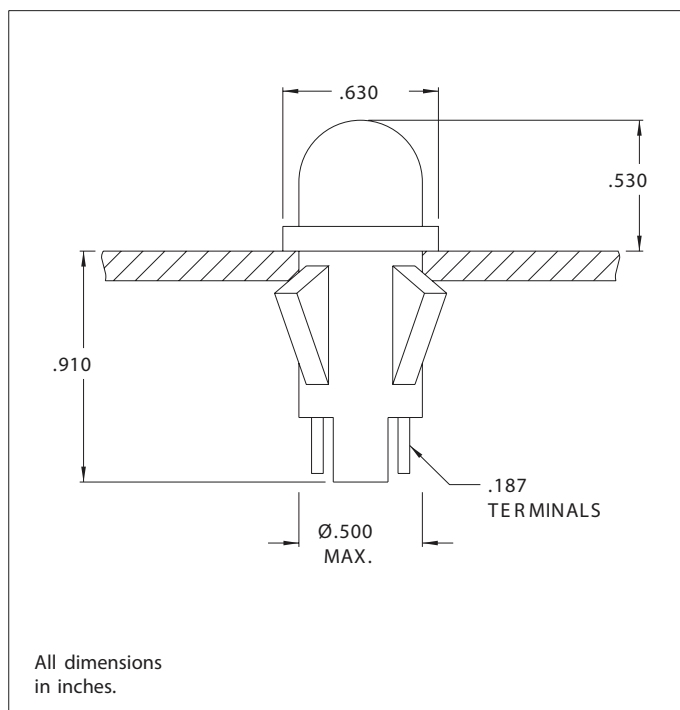

1050QA, 1051QA, 1052QA and 1053QA Series Non-Relampable Neon Indicator Lights



Mounting: Will snap-fit into Ø.500/.505 hole in panels .020/.100 thick. Push-on speednut SN0461 also available.

Terminals: Quick-connect, tinned brass

Lens: Polycarbonate

Bezel: Polished stainless steel.

Housing: White Nylon

Lens Color	Neon	
	Model No. (105-125VAC)	Model No. (208-250V)
Red	1050QA1	1051QA1
Clear	1050QA2	-
Amber	1050QA3	1051QA3
White	1050QA4	1051QA4
Green	1052QA5*	1053QA5*
Blue	1052QA6**	1053QA6**
Lamp used	C 2A+Resistor	
Quick Connect Terminals		

* Incorporates G2B lamp and resistor.
 ** Incorporates T2B lamp and resistor.
 Underwriters Laboratories (UL) File No. E20356

Compliance & Approvals



Mouser Electronics

Authorized Distributor

Click to View Pricing, Inventory, Delivery & Lifecycle Information:

VCC:

[1051QA1](#) [1051QA3](#) [1053QA5](#) [1050QA2](#) [1050QA3](#) [1050QA1](#) [1050QA4](#)