

THIS DRAWING IS UNPUBLISHED. RELEASED FOR PUBLICATION 20  
 © COPYRIGHT 20 BY - ALL RIGHTS RESERVED.

REVISIONS					
P	LTR	DESCRIPTION	DATE	DWN	APVD
	AI	REVISED PER ECR-17-015449	25OCT2017	BDA	KR

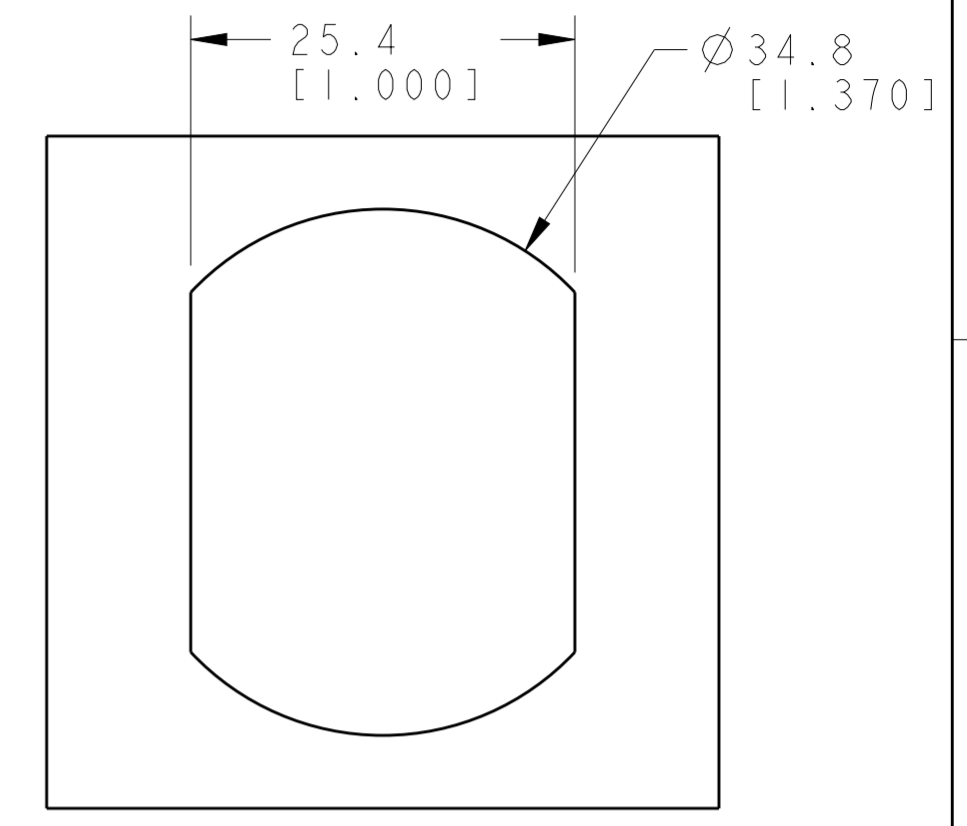

RECOMMENDED  
 PANEL CUT-OUT  
 SCALE 2:1

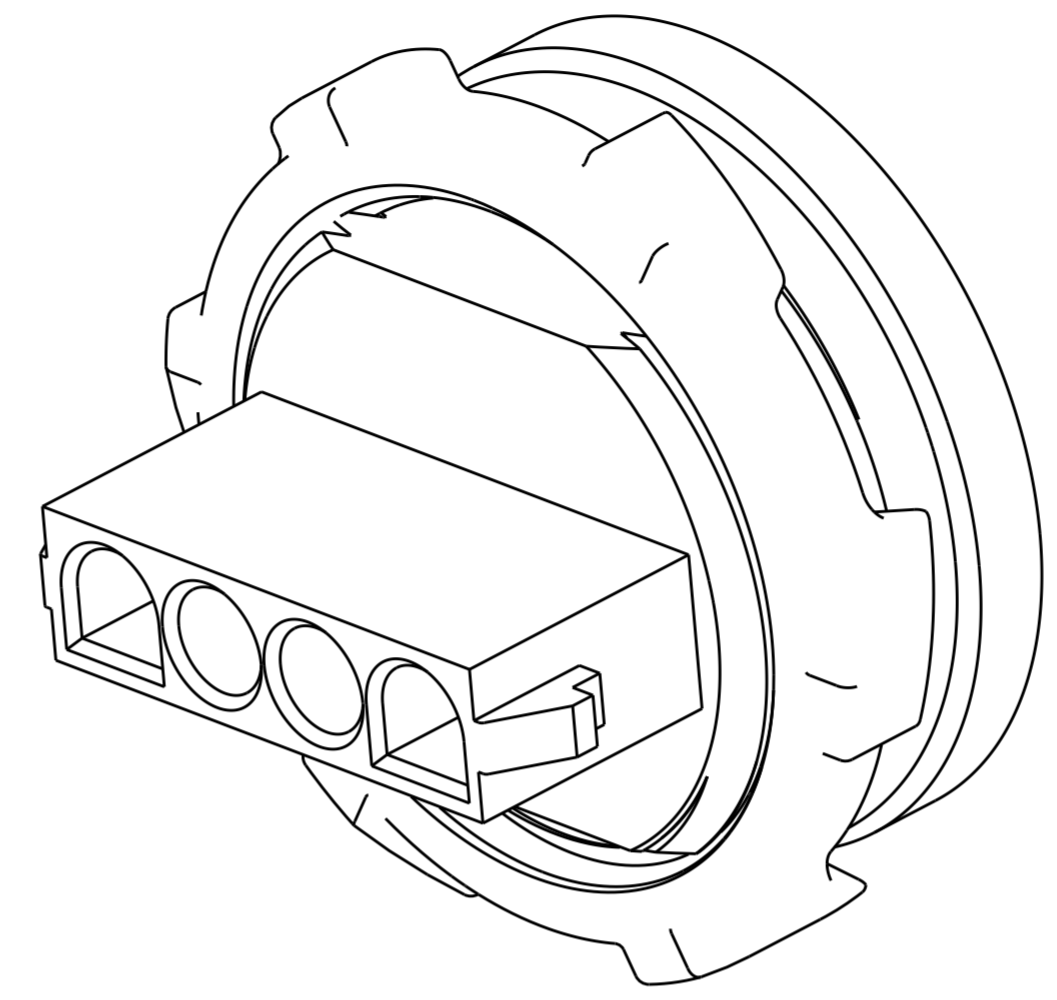
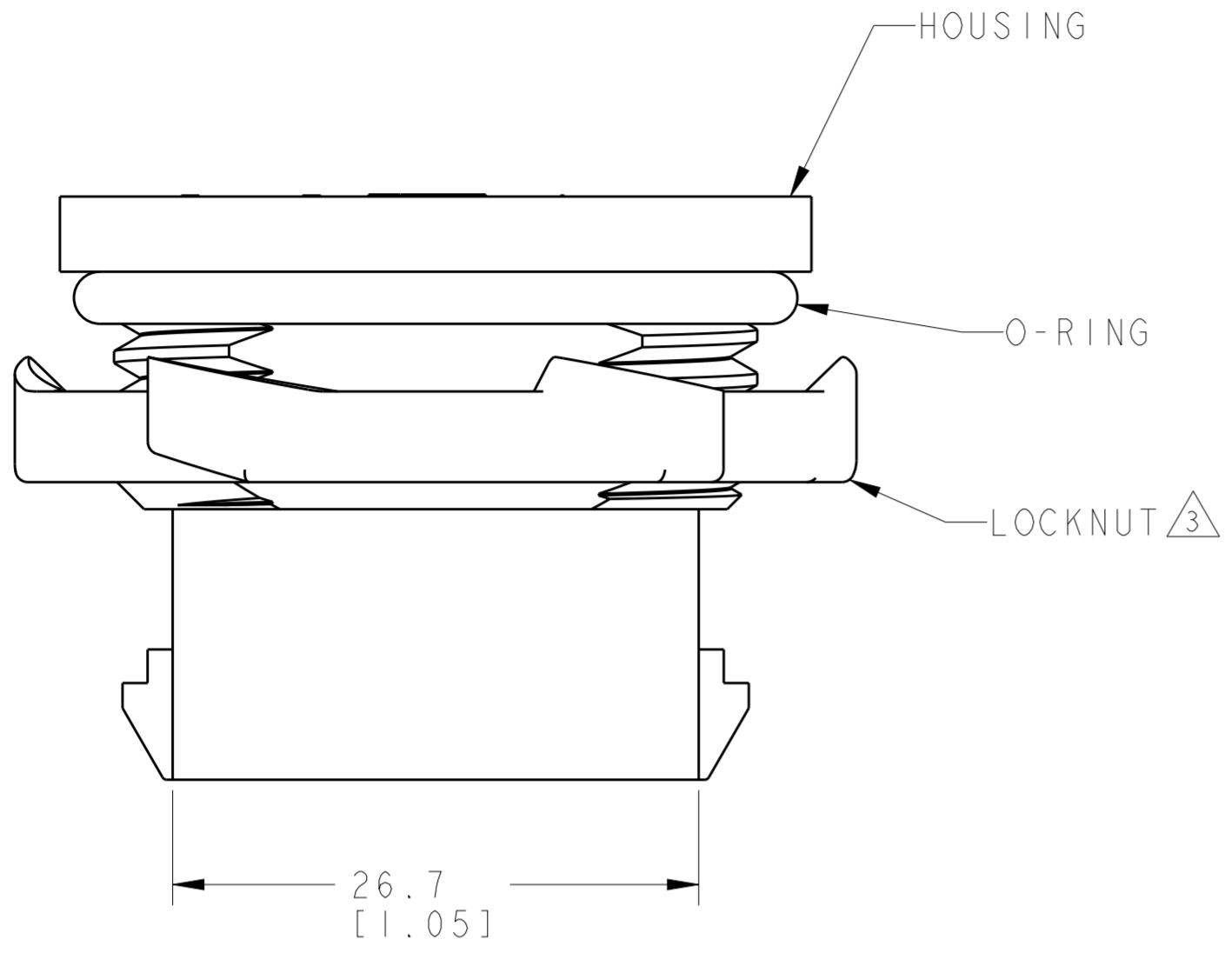
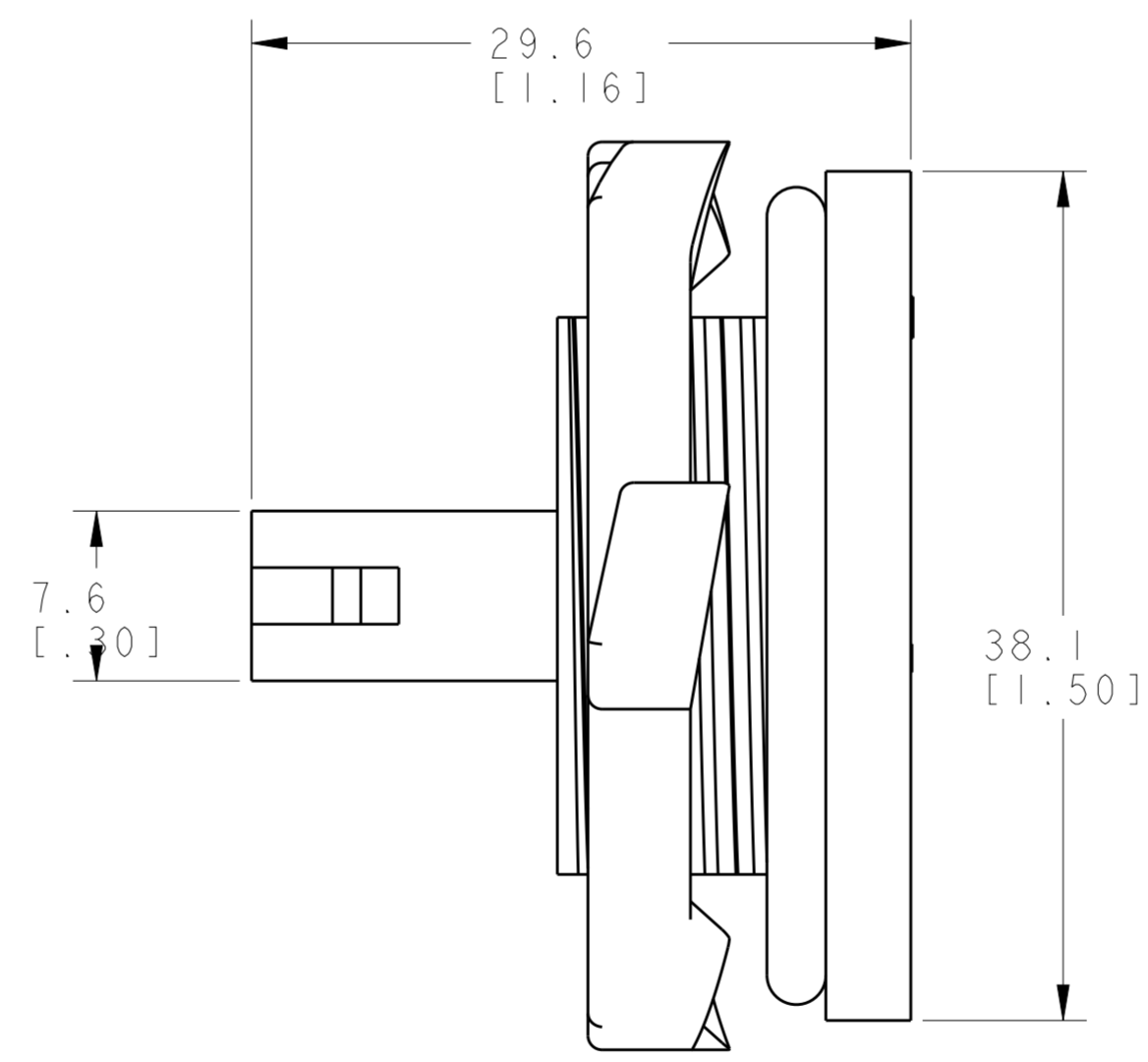
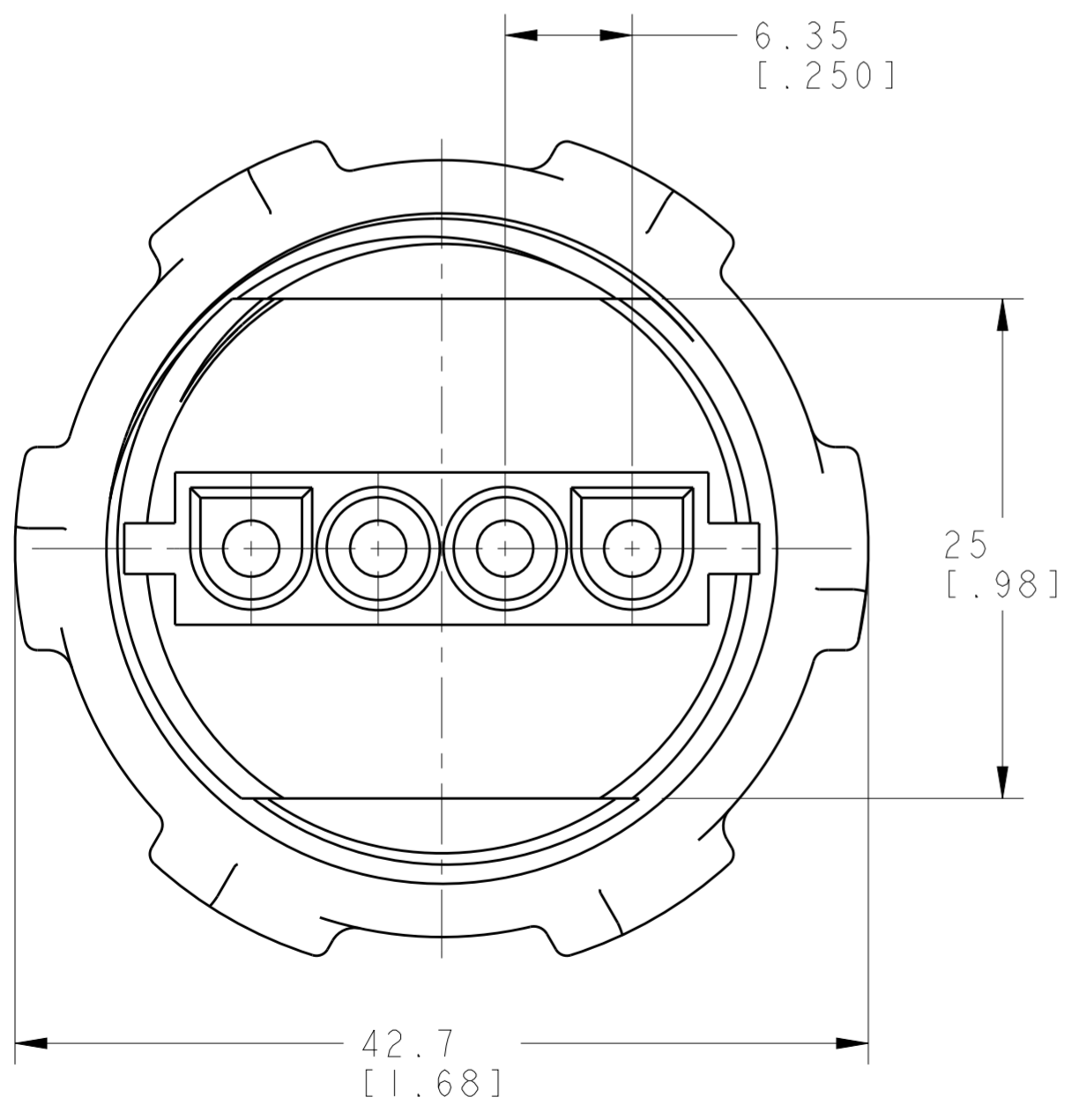

- △ LOCKNUT; METAL  
 HOUSING; NYLON, FLAME RETARDANT,  
 UL94-V0  
 O-RING; NEOPRENE
- △ LOCKNUT; PLATED
- △ LOCKNUT, SIX(6) OR EIGHT(8) SYMETRICAL  
 PLACED GRIP POINTS PERMISSIBLE.
- 4 DIMENSIONS SHOWN REPRESENT PRODUCT  
 IN DRY, AS MOLDED, CONDITION.  
 ADDITIONAL 2% GROWTH DUE TO SUBSEQUENT  
 MOISTURE ABSORPTION MAY OCCUR AND  
 SHOULD BE ACCOUNTED FOR.

1604256-1  
 PART NO

THIS DRAWING IS A CONTROLLED DOCUMENT.		DWN J.C. YOSLER 22APR2002	TE Connectivity	
DIMENSIONS: INCHES		CHK J.H. WEAVER 22APR2002		
TOLERANCES UNLESS OTHERWISE SPECIFIED:		APVD J.H. WEAVER 22APR2002	NAME BULKHEAD CONNECTOR ASSEMBLY 4 CIRCUIT, UNIVERSAL MATE-N-LOK(TM)	
0 PLC ±	±0.5 [.02]	PRODUCT SPEC	SIZE	RESTRICTED TO
1 PLC ±	±0.13 [.005]	APPLICATION SPEC	CAGE CODE	
2 PLC ±	±	WEIGHT	DRAWING NO	
3 PLC ±	±		A200779	
4 PLC ±	±		C-1604256	
ANGLES ±	±			
FINISH	△			
MATERIAL	△	CUSTOMER DRAWING	SCALE 3:1	SHEET OF REV AI