

THIS COPY IS PROVIDED ON A RESTRICTED BASIS AND IS NOT TO BE USED IN ANY WAY DETRIMENTAL TO THE INTERESTS OF PANDUIT CORP.

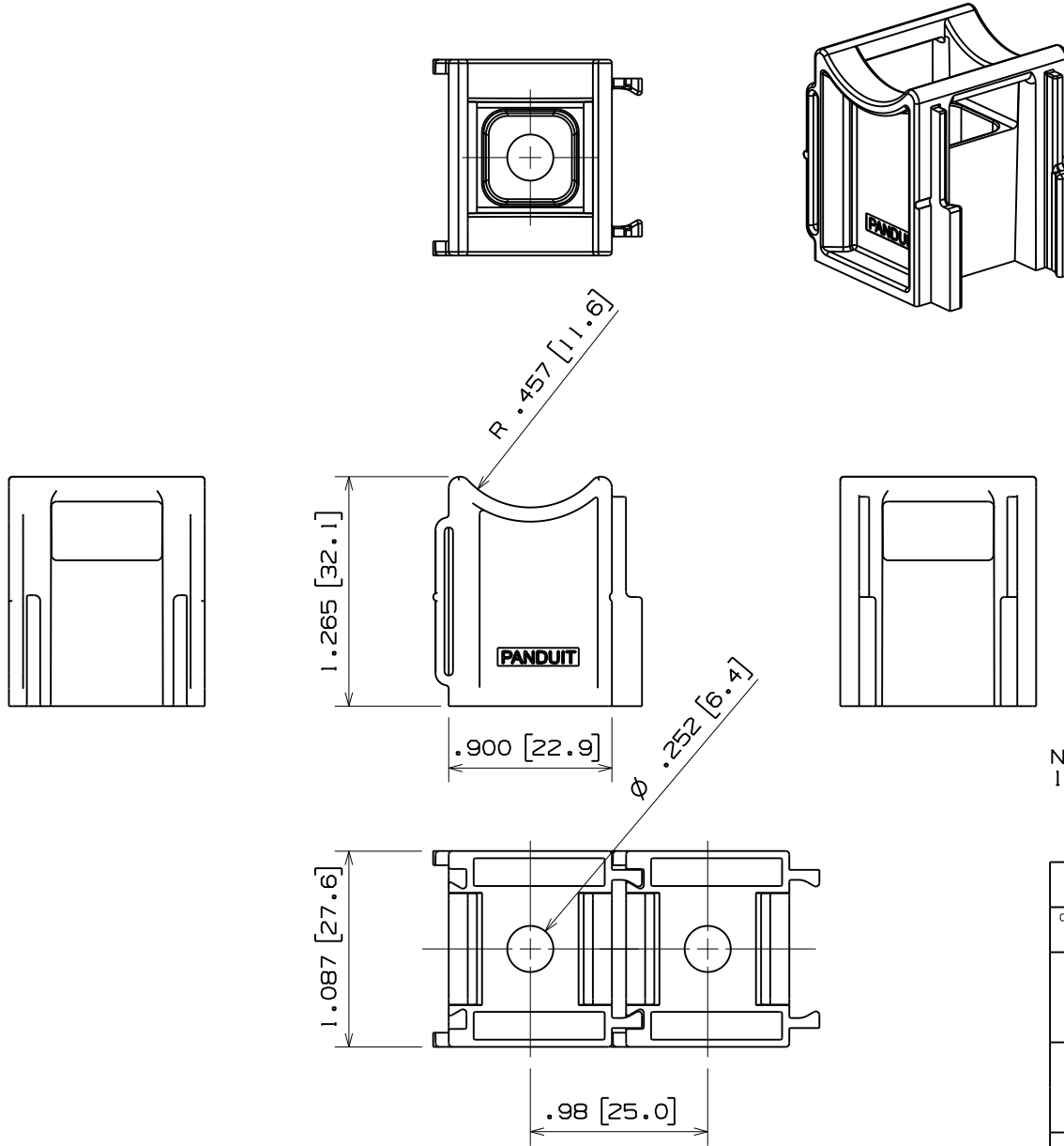

NOTES:  
 1. SEE WWW.PANDUIT.COM FOR PART NUMBER SUFFIX DESIGNATION FOR PACKAGE SIZE.

DIMENSIONS IN BRACKETS ARE METRIC [ mm ]	
CAD FILENAME/LAYERS 10B015CL_DC_GB3687BA_REV01	
<b>PANDUIT</b> CORP.      TINLEY PARK, ILLINOIS	
OMTM-S25 ON MACHINE TIE MOUNT	
UNLESS OTHERWISE SPECIFIED, DIMENSIONAL TOLERANCES ARE: (.X) ±0.05 (1.3) (.XXX) ±0.010 (0.25) (.XX) ±0.02 (0.5) ANGLES ±5°	UNLESS OTHERWISE SPECIFIED, ALL DIMENSIONS ARE GIVEN IN INCHES, THIRD ANGLE PROJECTION.
DRAWN BY <b>KLN</b>	MAT'L: <b>NYLON 6/6</b>
DATE <b>11/2/09</b>	SCALE <b>1 : 1</b>
CHK'D	DRAWING NO. <b>GB3687BA</b>
	DWG SIZE <b>A</b>

01	2/08/11	BWG	MJVE	MADE PART NUMBER OMTM-S25. REVISE NOTE TO SHOW PANDUIT.COM.	GB3678BA	01	PBC		
REV	DATE	BY	CHK	DESCRIPTION	ECN	- R	CUST	SUP	

# Mouser Electronics

Authorized Distributor

Click to View Pricing, Inventory, Delivery & Lifecycle Information:

[Panduit:](#)

[OMTM-S25-C0](#)