

Proximity Inductive Sensors DC Metal Face Types IA, M8, M12, M18 and M30

CARLO GAVAZZI



- Sensing distance: 1 to 15 mm
- Flush and non-flush types
- Long and short housing
- Rated operational voltage: 10 - 30 VDC
- Output: DC 100 mA, NPN or PNP
- Normally open, Normally closed
- Output indication: by yellow LED
- Protection: reverse polarity, short circuit, transients
- Cable and plug versions

Product Description

A family of metal face inductive proximity switches in industrial standard stainless steel housings (M8, M12, M18 and M30 types). Output indication: by yellow LED. Outputs are open collector NPN or PNP transistors. Available with cable and M8 or M12 plug.

These sensors stand up to

abrasion and impact caused by flying metal chips, grit and misaligned or vibrating targets. In addition, the stainless steel body resists against corrosion and chemical attack, by offering a higher level of protection for more reliable operation and longer life in harsh environments.

Ordering Key

IA08FLF01NOM5

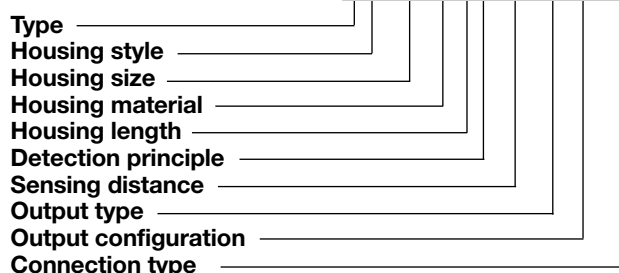

Type Selection M8, M12 and M18

Housing diameter	Connection	Housing style	Rated operating distance S_n	Ordering no. NPN Normally open	Ordering no. PNP Normally open	Ordering no. NPN Normally closed	Ordering no. PNP Normally closed
M8	Cable	Short	1 mm ¹⁾	IA 08 FSF 01 NO	IA 08 FSF 01 PO	IA 08 FSF 01 NC	IA 08 FSF 01 PC
M8	Plug	Short	1 mm ¹⁾	IA 08 FSF 01 NOM5	IA 08 FSF 01 POM5	IA 08 FSF 01 NCM5	IA 08 FSF 01 PCM5
M8	Cable	Long	1 mm ¹⁾	IA 08 FLF 01 NO	IA 08 FLF 01 PO	IA 08 FLF 01 NC	IA 08 FLF 01 PC
M8	Plug	Long	1 mm ¹⁾	IA 08 FLF 01 NOM5	IA 08 FLF 01 POM5	IA 08 FLF 01 NCM5	IA 08 FLF 01 PCM5
M8	Cable	Short	2 mm ²⁾	IA 08 FSN 02 NO	IA 08 FSN 02 PO	IA 08 FSN 02 NC	IA 08 FSN 02 PC
M8	Plug	Short	2 mm ²⁾	IA 08 FSN 02 NOM5	IA 08 FSN 02 POM5	IA 08 FSN 02 NCM5	IA 08 FSN 02 PCM5
M8	Cable	Long	2 mm ²⁾	IA 08 FLN 02 NO	IA 08 FLN 02 PO	IA 08 FLN 02 NC	IA 08 FLN 02 PC
M8	Plug	Long	2 mm ²⁾	IA 08 FLN 02 NOM5	IA 08 FLN 02 POM5	IA 08 FLN 02 NCM5	IA 08 FLN 02 PCM5
M12	Cable	Short	2 mm ¹⁾	IA 12 FSF 02 NO	IA 12 FSF 02 PO	IA 12 FSF 02 NC	IA 12 FSF 02 PC
M12	Plug	Short	2 mm ¹⁾	IA 12 FSF 02 NOM1	IA 12 FSF 02 POM1	IA 12 FSF 02 NCM1	IA 12 FSF 02 PCM1
M12	Cable	Long	2 mm ¹⁾	IA 12 FLF 02 NO	IA 12 FLF 02 PO	IA 12 FLF 02 NC	IA 12 FLF 02 PC
M12	Plug	Long	2 mm ¹⁾	IA 12 FLF 02 NOM1	IA 12 FLF 02 POM1	IA 12 FLF 02 NCM1	IA 12 FLF 02 PCM1
M12	Cable	Short	4 mm ²⁾	IA 12 FSN 04 NO	IA 12 FSN 04 PO	IA 12 FSN 04 NC	IA 12 FSN 04 PC
M12	Plug	Short	4 mm ²⁾	IA 12 FSN 04 NOM1	IA 12 FSN 04 POM1	IA 12 FSN 04 NCM1	IA 12 FSN 04 PCM1
M12	Cable	Long	4 mm ²⁾	IA 12 FLN 04 NO	IA 12 FLN 04 PO	IA 12 FLN 04 NC	IA 12 FLN 04 PC
M12	Plug	Long	4 mm ²⁾	IA 12 FLN 04 NOM1	IA 12 FLN 04 POM1	IA 12 FLN 04 NCM1	IA 12 FLN 04 PCM1
M18	Cable	Short	5 mm ¹⁾	IA 18 FSF 05 NO	IA 18 FSF 05 PO	IA 18 FSF 05 NC	IA 18 FSF 05 PC
M18	Plug	Short	5 mm ¹⁾	IA 18 FSF 05 NOM1	IA 18 FSF 05 POM1	IA 18 FSF 05 NCM1	IA 18 FSF 05 PCM1
M18	Cable	Long	5 mm ¹⁾	IA 18 FLF 05 NO	IA 18 FLF 05 PO	IA 18 FLF 05 NC	IA 18 FLF 05 PC
M18	Plug	Long	5 mm ¹⁾	IA 18 FLF 05 NOM1	IA 18 FLF 05 POM1	IA 18 FLF 05 NCM1	IA 18 FLF 05 PCM1
M18	Cable	Short	8 mm ²⁾	IA 18 FSN 08 NO	IA 18 FSN 08 PO	IA 18 FSN 08 NC	IA 18 FSN 08 PC
M18	Plug	Short	8 mm ²⁾	IA 18 FSN 08 NOM1	IA 18 FSN 08 POM1	IA 18 FSN 08 NCM1	IA 18 FSN 08 PCM1
M18	Cable	Long	8 mm ²⁾	IA 18 FLN 08 NO	IA 18 FLN 08 PO	IA 18 FLN 08 NC	IA 18 FLN 08 PC
M18	Plug	Long	8 mm ²⁾	IA 18 FLN 08 NOM1	IA 18 FLN 08 POM1	IA 18 FLN 08 NCM1	IA 18 FLN 08 PCM1

¹⁾ For flush mounting in metal ²⁾ For non-flush mounting in metal

Type Selection M30

Housing diameter	Connection	Housing style	Rated operating distance S_n	Ordering no. NPN Normally open	Ordering no. PNP Normally open	Ordering no. NPN Normally closed	Ordering no. PNP Normally closed
M30	Cable	Short	10 mm ¹⁾	IA 30 FSF 10 NO	IA 30 FSF 10 PO	IA 30 FSF 10 NC	IA 30 FSF 10 PC
M30	Plug	Short	10 mm ¹⁾	IA 30 FSF 10 NOM1	IA 30 FSF 10 POM1	IA 30 FSF 10 NCM1	IA 30 FSF 10 PCM1
M30	Cable	Long	10 mm ¹⁾	IA 30 FLF 10 NO	IA 30 FLF 10 PO	IA 30 FLF 10 NC	IA 30 FLF 10 PC
M30	Plug	Long	10 mm ¹⁾	IA 30 FLF 10 NOM1	IA 30 FLF 10 POM1	IA 30 FLF 10 NCM1	IA 30 FLF 10 PCM1
M30	Cable	Short	15 mm ²⁾	IA 30 FSN 15 NO	IA 30 FSN 15 PO	IA 30 FSN 15 NC	IA 30 FSN 15 PC
M30	Plug	Short	15 mm ²⁾	IA 30 FSN 15 NOM1	IA 30 FSN 15 POM1	IA 30 FSN 15 NCM1	IA 30 FSN 15 PCM1
M30	Cable	Long	15 mm ²⁾	IA 30 FLN 15 NO	IA 30 FLN 15 PO	IA 30 FLN 15 NC	IA 30 FLN 15 PC
M30	Plug	Long	15 mm ²⁾	IA 30 FLN 15 NOM1	IA 30 FLN 15 POM1	IA 30 FLN 15 NCM1	IA 30 FLN 15 PCM1

1) For flush mounting in metal 2) For non-flush mounting in metal

Specifications

Rated operational voltage (U_B)	10 to 30 VDC	Housing material	Body, Front	Stainless steel AISI 304
Ripple	< 10%		Backpart	
Output current (I_a)	≤ 100 mA @ 50°C	Plug	PA-66	
No load supply current (I_o)	IA08, IA12Fx, IA18Fx, IA30Fx	Cable	PVC	
	IA12FxN, IA18FxN, IA30FxN	Nuts	Stainless steel	
Voltage drop (U_d)	IA08	Connection	Cable	
	IA12, IA18, IA30		IA08	2 m, 3 x 0.15 mm ² , Ø 3 mm, Grey PVC
Protection	Reverse polarity, short-circuit, transients	IA12, IA18	2 m, 3 x 0.15 mm ² , Ø 4 mm, Grey PVC	
		IA30	2 m, 3 x 0.50 mm ² , Ø 5.8 mm, Grey PVC	
Voltage transient	1 kV	Plug		
Power ON delay (t_v)	< 10 ms	IA08	M8 x 1	
Operating frequency (f)	IA08Fx	IA12, IA18, IA30	M12 x 1	
	IA12Fx	Cables for plug (-1)	CONH1A/CONH1O series	
	IA12FxN			
	IA18Fx	Degree of protection	IP 67	
	IA18FxN	Weight	IA08FSFx	33 g
	IA18FxM1		IA08FSFxM5	33 g
	IA18FxN1		IA08FLFx	33 g
	IA30FSFx		IA08FLFxM5	18 g
	IA30FSNx		IA08FSNx	32 g
	IA30FLFx		IA08FSNxM5	32 g
	IA30FLNx		IA08FLNx	32 g
	IA30FxM1		IA08FLNxM5	17 g
IA30FxN1	IA12FSFx		31 g	
	IA12FSFxM1		40 g	
	IA12FLFx		67 g	
	IA12FLFxM1		153 g	
Indication for output ON	LED, yellow	IA12FSNx	30 g	
Operating sensing distance (S_a)	$0 \leq S_a \leq 0.81 \times S_n$	IA12FSNxM1	38 g	
Effective operating distance (S_r)	$0.9 \times S_n \leq S_r \leq 1.1 \times S_n$	IA12FLNx	65 g	
Usable operating distance (S_u)	$0.9 \times S_r \leq S_u \leq 1.1 \times S_r$	IA12FLNxM1	144 g	
Repeated accuracy (R)	≤ 5%	IA18FSFx	110 g	
Differential travel (H) (Hysteresis)	1 to 20% of sensing dist.	IA18FSFxM1	74 g	
		IA18FLFx	153 g	
Ambient temperature	Operating Storage Humidity (non-condensing)	IA18FLFxM1	94 g	
		IA18FSNx	92 g	
		IA18FSNxM1	70 g	
		IA18FLNx	144 g	
		IA18FLNxM1	91 g	

Specifications (cont.)

Weight (cont.)		Tightening torque	
IA30FSFxx	146 g	IA08	4.5 Nm
IA30FSFxxM1	200 g	IA12	25.0 Nm
IA30FLFxx	217 g	IA18	60.0 Nm
IA30FLFxxM1	187 g	IA30	230.0 Nm
IA30FSNxx	138 g	CE-marking	Yes
IA30FSNxxM1	200 g		
IA30FLNxx	207 g		
IA30FLNxxM1	179 g		

Dimensions

Type	Description	A (mm)	B (mm)	C (mm)	D (mm)	E (mm)
IA 08 FSF 01 xx	M8 x 1 x 30	M8 x 1	30	-	-	-
IA 08 FSF 01 xx M5	M8 x 1 x 45	M8 x 1	45	-	-	M8 x 1
IA 08 FLF 01 xx	M8 x 1 x 45	M8 x 1	45	-	-	-
IA 08 FLF 01 xx M5	M8 x 1 x 60	M8 x 1	60	40	-	M8 x 1
IA 08 FSN 02 xx	M8 x 1 x 30	M8 x 1	30	26	4	-
IA 08 FSN 02 xx M5	M8 x 1 x 45	M8 x 1	45	41	4	M8 x 1
IA 08 FLN 02 xx	M8 x 1 x 45	M8 x 1	45	41	4	-
IA 08 FLN 02 xx M5	M8 x 1 x 60	M8 x 1	60	56	4	M8 x 1
IA 12 FSF 02 xx	M12 x 1 x 30	M12 x 1	30	-	-	-
IA 12 FSF 02 xx M1	M12 x 1 x 50	M12 x 1	50	-	-	M12 x 1
IA 12 FLF 02 xx	M12 x 1 x 50	M12 x 1	50	-	-	-
IA 12 FLF 02 xx M1	M12 x 1 x 68	M12 x 1	68	42	-	M12 x 1
IA 12 FSN 04 xx	M12 x 1 x 30	M12 x 1	30	22	8	-
IA 12 FSN 04 xx M1	M12 x 1 x 50	M12 x 1	50	42	8	M12 x 1
IA 12 FLN 04 xx	M12 x 1 x 50	M12 x 1	50	42	8	-
IA 12 FLN 04 xx M1	M12 x 1 x 68	M12 x 1	68	60	8	M12 x 1
IA 18 FSF 05 xx	M18 x 1 x 35	M18 x 1	35	-	-	-
IA 18 FSF 05 xx M1	M18 x 1 x 48	M18 x 1	48	-	-	M12 x 1
IA 18 FLF 05 xx	M18 x 1 x 55	M18 x 1	55	-	-	-
IA 18 FLF 05 xx M1	M18 x 1 x 79	M18 x 1	79	65	-	M12 x 1
IA 18 FSN 08 xx	M18 x 1 x 35	M18 x 1	35	23	12	-
IA 18 FSN 08 xx M1	M18 x 1 x 48	M18 x 1	48	36	12	M12 x 1
IA 18 FLN 08 xx	M18 x 1 x 55	M18 x 1	55	43	12	-
IA 18 FLN 08 xx M1	M18 x 1 x 79	M18 x 1	79	67	12	M12 x 1
IA 30 FSF 10 xx	M30 x 1.5 x 35	M30 x 1.5	35	-	-	-
IA 30 FSF 10 xx M1	M30 x 1.5 x 48	M30 x 1.5	48	-	-	M12 x 1
IA 30 FLF 10 xx	M30 x 1.5 x 55	M30 x 1.5	55	-	-	-
IA 30 FLF 10 xx M1	M30 x 1.5 x 78	M30 x 1.5	78	-	-	M12 x 1
IA 30 FSN 15 xx	M30 x 1.5 x 35	M30 x 1.5	35	25	10	-
IA 30 FSN 15 xx M1	M30 x 1.5 x 48	M30 x 1.5	48	38	10	M12 x 1
IA 30 FLN 15 xx	M30 x 1.5 x 55	M30 x 1.5	55	45	10	-
IA 30 FLN 15 xx M1	M30 x 1.5 x 78	M30 x 1.5	78	68	10	M12 x 1

Dimensions: cable type

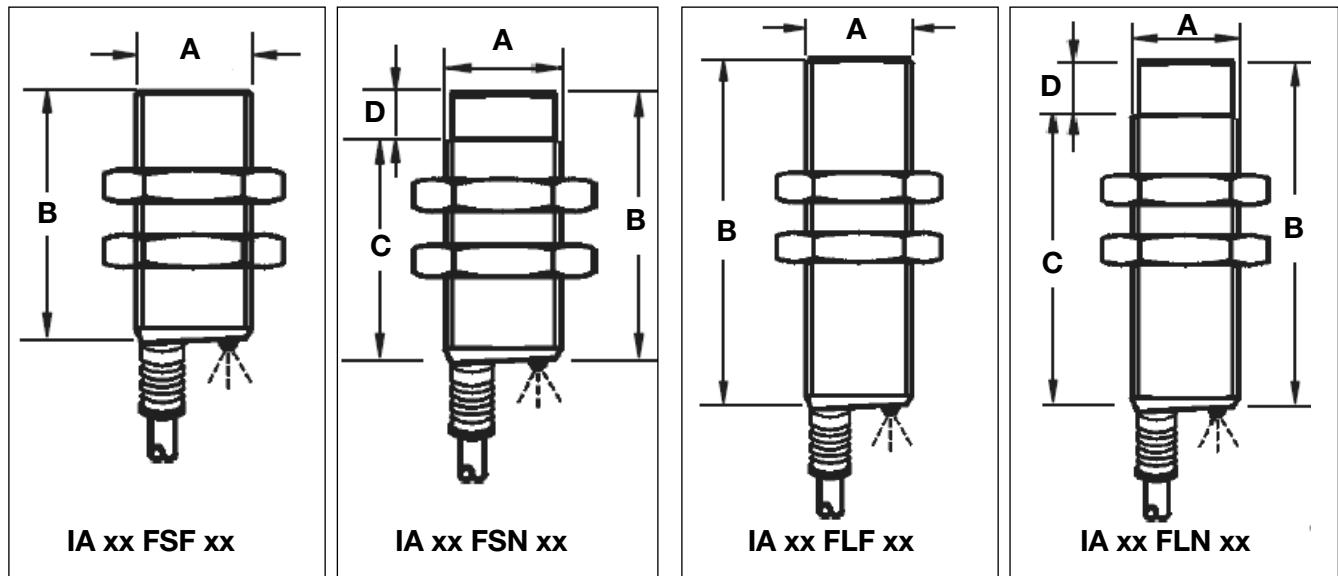

Dimensions: plug type

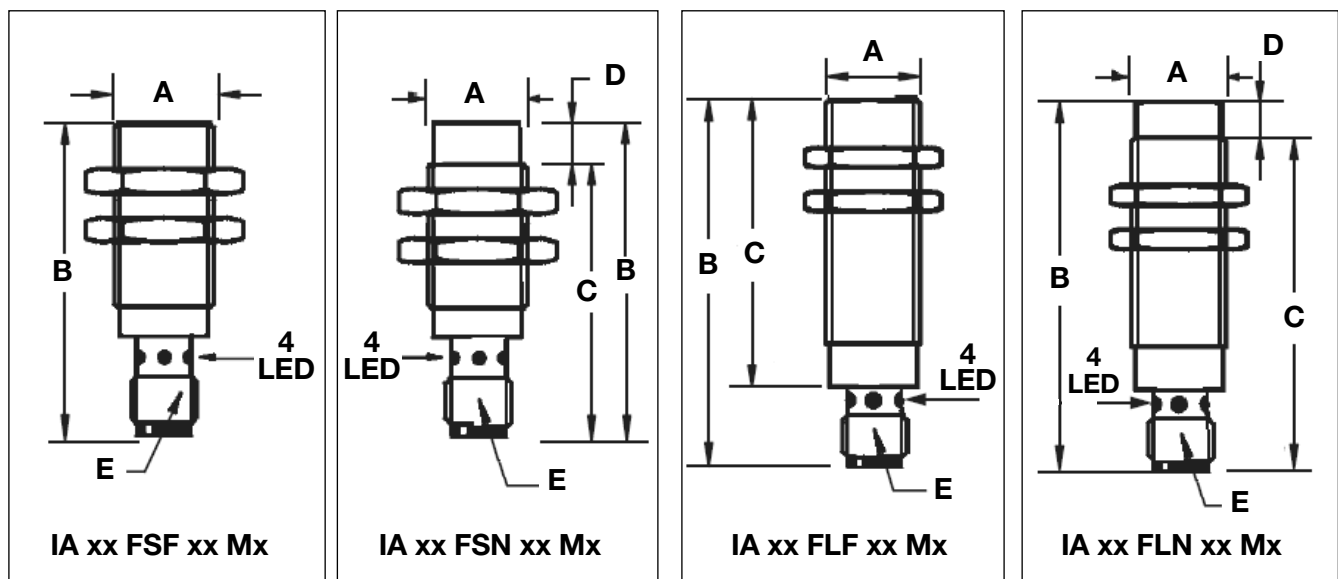

Wiring Diagrams

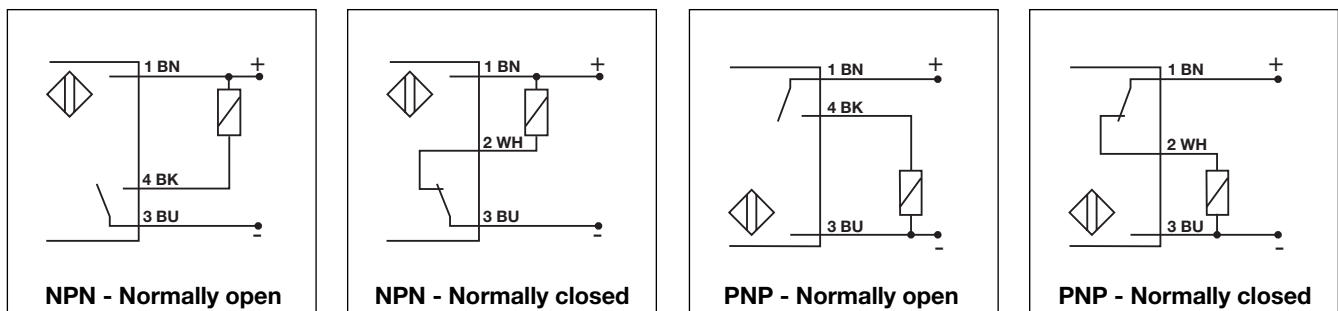

Installation Hints

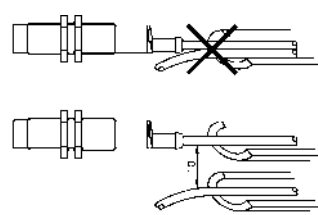
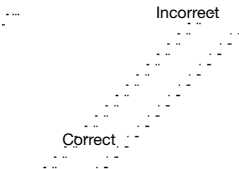
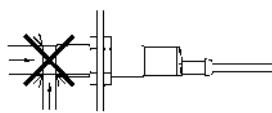
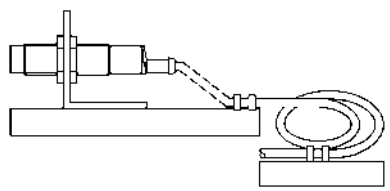
<p>To avoid interference from inductive voltage/current peaks, separate the prox. switch power cables from any other power cables, e.g. motor, contactor or solenoid cables</p> 	<p>Relief of cable strain</p>  <p>The cable should not be pulled</p>	<p>Protection of the sensing face</p>  <p>A proximity switch should not serve as mechanical stop</p>	<p>Switch mounted on mobile carrier</p>  <p>Any repetitive flexing of the cable should be avoided</p>
---	---	--	--

Delivery Contents

- Inductive proximity switch IA..
- 2 stainless steel nuts
- 1 stainless steel washer
- Packaging: plastic bag

Mouser Electronics

Authorized Distributor

Click to View Pricing, Inventory, Delivery & Lifecycle Information:

Carlo Gavazzi:

[IA08FLN02NOM5](#) [IA08FLN02PCM5](#) [IA08FSN02PCM5](#) [IA12FLF02NO](#) [IA12FSF02NC](#) [IA12FSF02NOM1](#)
[IA18FSF05POM1](#) [IA18FSN08NCM1](#) [IA30FSN15POM1](#) [IA08FLF01PCM5](#) [IA08FSF01PC](#) [IA12FLF02POM1](#)
[IA12FLN04NCM1](#) [IA12FLN04NO](#) [IA12FSN04NC](#) [IA12FSN04NOM1](#) [IA18FLF05NCM1](#) [IA18FSN08POM1](#)
[IA08FSN02NO](#) [IA12FLF02NOM1](#) [IA12FLN04PC](#) [IA12FSF02PCM1](#) [IA12FSN04PC](#) [IA18FLF05NO](#) [IA18FLF05PC](#)
[IA18FSF05PC](#) [IA18FSF05PO](#) [IA30FLN15NOM1](#) [IA30FSF10NO](#) [IA30FSN15NOM1](#) [IA08FSN02PO](#)
[IA08FSN02POM5](#) [IA12FSF02NCM1](#) [IA12FSF02NO](#) [IA18FLF05POM1](#) [IA18FLN08NC](#) [IA30FLN15PCM1](#)
[IA30FSN15PO](#) [IA08FLN02PC](#) [IA08FLN02PO](#) [IA08FSN02PC](#) [IA12FLF02NC](#) [IA12FLF02NCM1](#) [IA18FLF05PO](#)
[IA18FLN08NCM1](#) [IA18FSN08NC](#) [IA18FSN08NO](#) [IA30FLN15PC](#) [IA30FLN15PO](#) [IA30FLN15POM1](#) [IA30FSN15PC](#)
[IA30FSN15PCM1](#) [IA12FLN04NC](#) [IA12FLN04NOM1](#) [IA12FSN04NCM1](#) [IA12FSN04NO](#) [IA18FLN08PO](#)
[IA30FLF10NOM1](#) [IA30FLF10PCM1](#) [IA30FLF10PO](#) [IA08FLN02NO](#) [IA08FSN02NC](#) [IA12FLF02PCM1](#) [IA12FSN04PO](#)
[IA18FLN08NOM1](#) [IA18FLN08PCM1](#) [IA18FSN08NOM1](#) [IA18FSN08PCM1](#) [IA30FLN15NCM1](#) [IA08FSF01POM5](#)
[IA08FSN02NOM5](#) [IA12FLN04POM1](#) [IA12FSN04PCM1](#) [IA18FSF05NOM1](#) [IA18FSF05PCM1](#) [IA30FLF10NCM1](#)
[IA30FSF10NCM1](#) [IA30FSF10NOM1](#) [IA08FLF01NOM5](#) [IA08FLF01PC](#) [IA08FSF01NOM5](#) [IA08FSF01PO](#)
[IA18FLF05NC](#) [IA18FLN08POM1](#) [IA18FSF05NC](#) [IA18FSF05NCM1](#) [IA30FLF10PC](#) [IA30FLF10POM1](#) [IA08FLF01PO](#)
[IA08FSF01PCM5](#) [IA30FSF10PC](#) [IA30FSF10PCM1](#) [IA30FSF10PO](#) [IA30FSF10POM1](#) [IA08FLF01NC](#)
[IA08FLF01POM5](#) [IA08FSF01NC](#) [IA12FLF02PC](#) [IA08FLF01NO](#) [IA08FLF01NCM5](#)