

Enhancement Mode pHEMT Technology (E-pHEMT) Low Noise Amplifier

The MML20211H is a single-stage low noise amplifier (LNA) with active bias and high isolation for use in cellular infrastructure applications. It is designed for a range of low noise, high linearity applications such as pico cell, femto cell, tower mounted amplifiers (TMA) and receiver front end circuits. It operates from a single voltage supply and is suitable for applications with frequencies from 1400 to 2800 MHz such as TD-SCDMA, W-CDMA, UMTS, PCS, LTE and BWA.

Features

- Ultra Low Noise Figure: 0.65 dB @ 2140 MHz
- Frequency: 1400–2800 MHz
- High Reverse Isolation: -35 dB @ 2140 MHz
- P1dB: 21.3 dBm @ 2140 MHz
- Small-Signal Gain: 18.6 dB @ 2140 MHz (adjustable externally)
- Third Order Output Intercept Point: 33 dBm @ 2140 MHz
- Active Bias Control (adjustable externally)
- Single 5 V Supply
- Supply Current: 60 mA
- 50 Ohm Operation (some external matching required)
- Cost-effective 8-pin, 2 mm DFN Surface Mount Plastic Package
- In Tape and Reel. T1 Suffix = 1,000 Units, 12 mm Tape Width, 7-inch Reel.

MML20211HT1

**1400–2800 MHz, 18.6 dB
21.3 dBm
E-pHEMT LNA**



DFN 2 x 2

Table 1. Typical Performance (1)

Characteristic	Symbol	1400 MHz	1800 MHz	2140 MHz	2700 MHz	Unit
Noise Figure (2)	NF	0.65	0.65	0.65	0.85	dB
Input Return Loss (S11)	IRL	-19.5	-16	-16.7	-17.3	dB
Output Return Loss (S22)	ORL	-24.9	-28	-26.6	-20	dB
Small-Signal Gain (S21)	G _p	21.3	19.7	18.6	18.1	dB
Power Output @ 1dB Compression	P1dB	21.1	21.1	21.3	19.6	dBm
Third Order Input Intercept Point	IIP3	10.8	12.5	14.4	14.9	dBm
Third Order Output Intercept Point	OIP3	32.1	32.2	33	33	dBm

1. V_{DD} = 5 Vdc, T_A = 25°C, 50 ohm system, application circuit tuned for specified frequency.
2. Noise figure value calculated with connector losses removed.

Table 2. Maximum Ratings

Rating	Symbol	Value	Unit
Supply Voltage	V _{DD}	6	V
Supply Current	I _{DD}	200	mA
RF Input Power	P _{in}	22	dBm
Storage Temperature Range	T _{stg}	-65 to +150	°C
Junction Temperature	T _J	175	°C

Table 3. Thermal Characteristics

Characteristic	Symbol	Value (3)	Unit
Thermal Resistance, Junction to Case Case Temperature 87°C, 5 Vdc, I _{DD} = 60 mA, no RF applied	R _{θJC}	43.4	°C/W

3. Refer to AN1955, *Thermal Measurement Methodology of RF Power Amplifiers*. Go to <http://www.freescale.com/rf>. Select Documentation/Application Notes - AN1955.

Table 4. Electrical Characteristics ($V_{DD} = 5 \text{ Vdc}$, 2140 MHz, $T_A = 25^\circ\text{C}$, 50 ohm system, in Freescale Application Circuit)

Characteristic	Symbol	Min	Typ	Max	Unit
Small-Signal Gain (S21)	G_p	15	18.6	—	dB
Input Return Loss (S11)	IRL	—	-16.7	—	dB
Output Return Loss (S22)	ORL	—	-26.6	—	dB
Power Output @ 1dB Compression	P1dB	—	21.3	—	dBm
Third Order Input Intercept Point	IIP3	—	14.4	—	dBm
Third Order Output Intercept Point	OIP3	—	33	—	dBm
Reverse Isolation (S12)	S12	—	-35	—	dB
Noise Figure (1)	NF	—	0.65	—	dB
Supply Current (2)	I_{DD}	45	60	85	mA
Supply Voltage	V_{DD}	—	5	—	V

- Noise figure value calculated with connector losses removed.
- DC current measured with no RF signal applied.

Table 5. Functional Pin Description

Pin Number	Pin Function
1	RF_{in}
2	RF_{in}
3	RF Input Matching Termination
4	Bias Voltage DC Supply
5	RF Feedback
6	RF_{out} /DC Supply
7	RF_{out} /DC Supply
8	No Connection

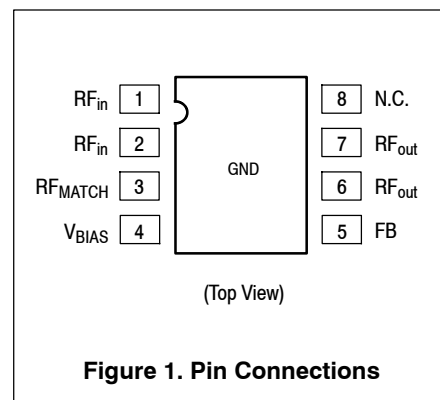

Table 6. ESD Protection Characteristics

Test Methodology	Class
Human Body Model (per JESD22-A114)	0
Machine Model (per EIA/JESD22-A115)	A
Charge Device Model (per JESD22-C101)	IV

Table 7. Moisture Sensitivity Level

Test Methodology	Rating	Package Peak Temperature	Unit
Per JESD22-A113, IPC/JEDEC J-STD-020	1	260	$^\circ\text{C}$

50 OHM APPLICATION CIRCUIT: 2140 MHz

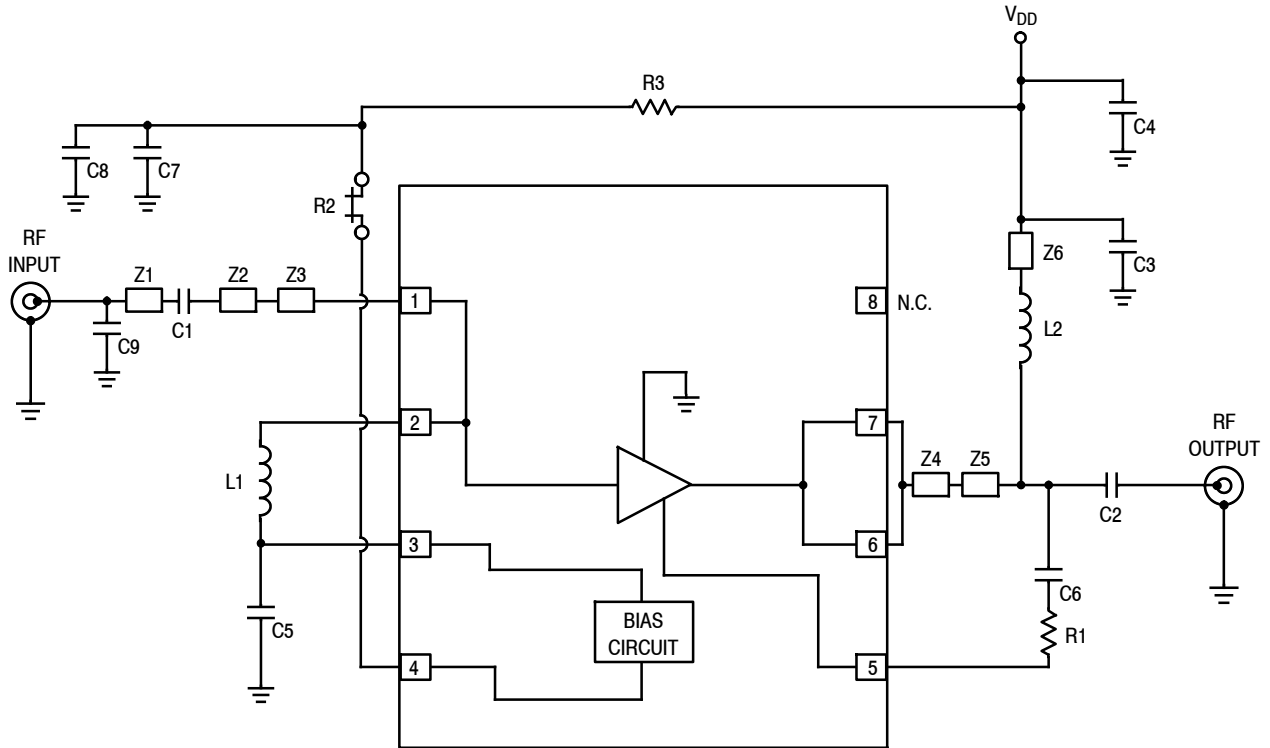

Z1	0.080" x 0.021" Microstrip	Z4	0.020" x 0.031" Microstrip
Z2	0.218" x 0.021" Microstrip	Z5	0.038" x 0.021" Microstrip
Z3	0.044" x 0.011" Microstrip	Z6	0.021" x 0.080" Microstrip

Figure 2. MML20211HT1 Test Circuit Schematic

Table 8. MML20211HT1 Test Circuit Component Designations and Values

Part	Description	Part Number	Manufacturer
C1, C5	18 pF Chip Capacitors	GJM1555C1H180JB01D	Murata
C2, C3, C6, C7	18 pF Chip Capacitors	GRM1555C1H180JA01D	Murata
C4, C8	0.1 μ F Chip Capacitors	GRM155R61A104KA01D	Murata
C9	0.6 pF Chip Capacitor	GJM1555C1HR60BB01D	Murata
L1, L2	3.6 nH Chip Inductors	0402HP-3N6XGL	Coilcraft
R1	180 Ω , 1/16 W Chip Resistor	RC0402FR-07180RL	Yageo
R2	0 Ω , 1 A Chip Resistor	ERJ2GE0R00X	Panasonic
R3	1.5 k Ω , 1/16 W Chip Resistor	RC0402FR-071K5L	Yageo
PCB	0.010", $\epsilon_r = 3.38$, Multilayer	IS680-3.38	Isola

50 OHM APPLICATION CIRCUIT: 2140 MHz

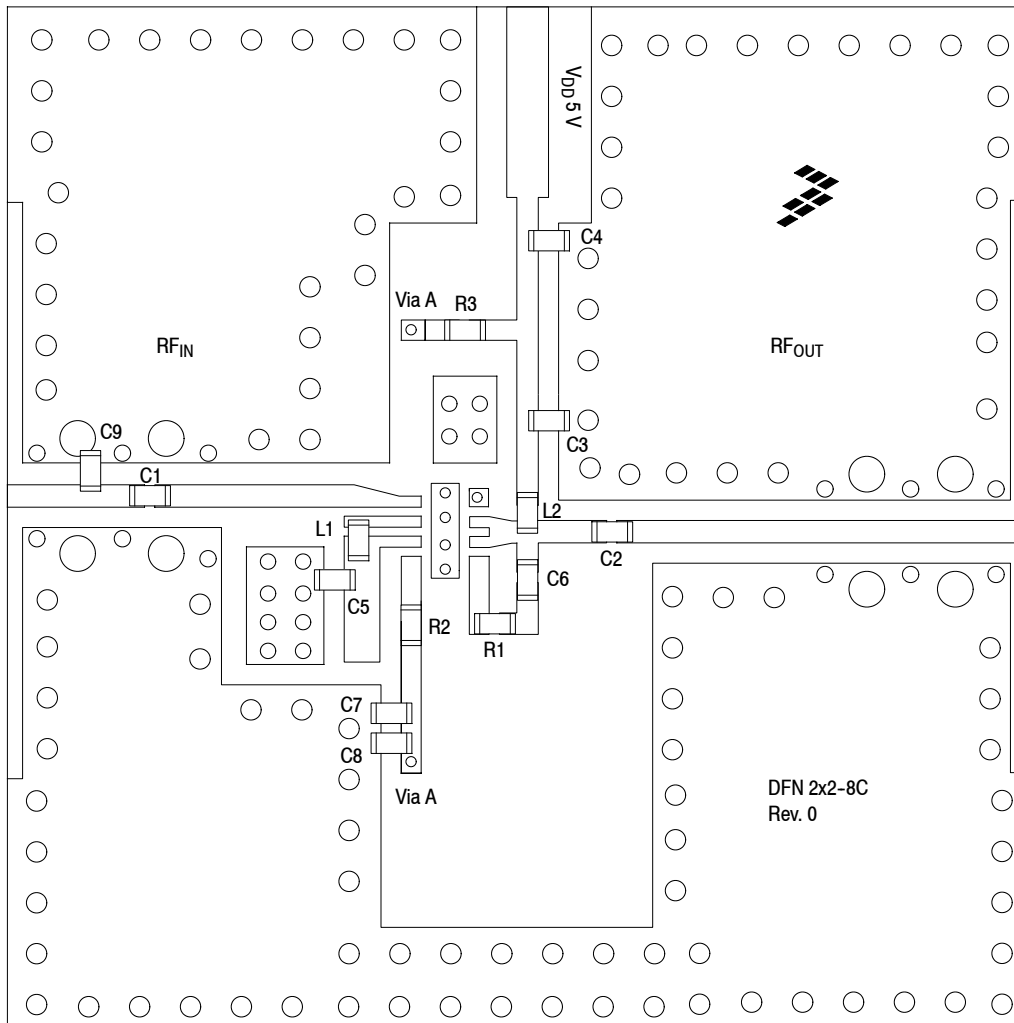

NOTE: To achieve optimal noise performance, it is critical that proper biasing, input matching, supply decoupling and grounding are employed.

Figure 3. MML2021HT1 Test Circuit Component Layout

Table 8. MML2021HT1 Test Circuit Component Designations and Values

Part	Description	Part Number	Manufacturer
C1, C5	18 pF Chip Capacitors	GJM1555C1H180JB01D	Murata
C2, C3, C6, C7	18 pF Chip Capacitors	GRM1555C1H180JA01D	Murata
C4, C8	0.1 μ F Chip Capacitors	GRM155R61A104KA01D	Murata
C9	0.6 pF Chip Capacitor	GJM1555C1HR60BB01D	Murata
L1, L2	3.6 nH Chip Inductors	0402HP-3N6XGL	Coilcraft
R1	180 Ω , 1/16 W Chip Resistor	RC0402FR-07180RL	Yageo
R2	0 Ω , 1 A Chip Resistor	ERJ2GE0R00X	Panasonic
R3	1.5 k Ω , 1/16 W Chip Resistor	RC0402FR-071K5L	Yageo
PCB	0.010", $\epsilon_r = 3.38$, Multilayer	IS680-3.38	Isola

(Test Circuit Component Designations and Values repeated for reference.)

50 OHM TYPICAL CHARACTERISTICS: 2140 MHz

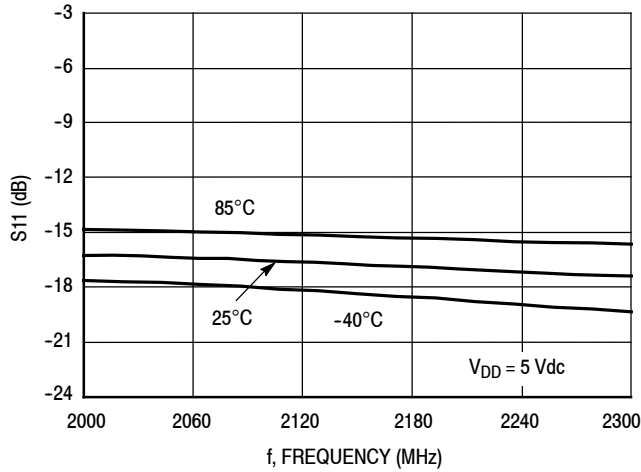

Figure 4. S11 versus Frequency versus Temperature

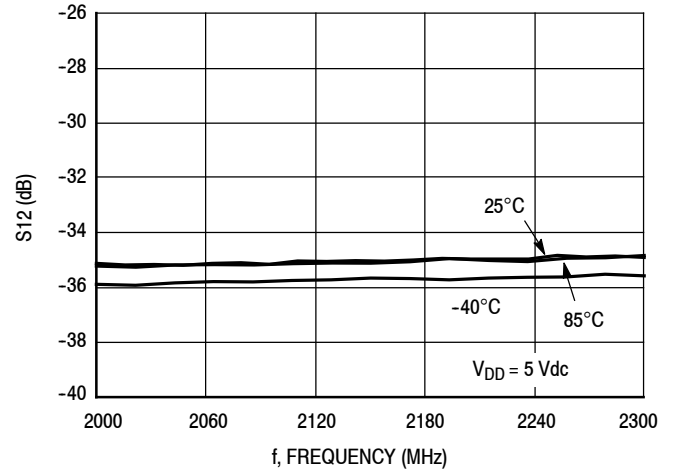

Figure 5. S12 versus Frequency versus Temperature

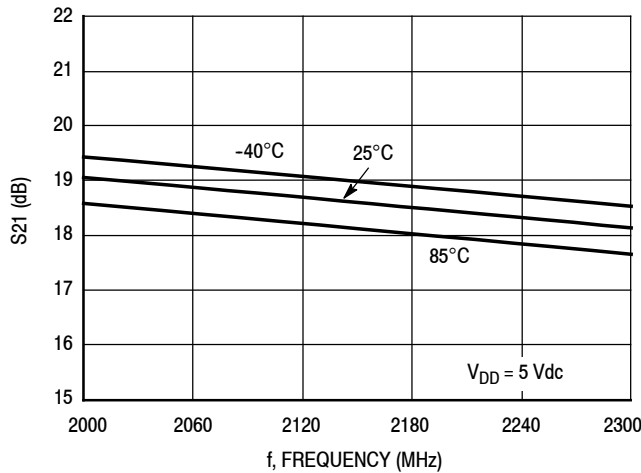

Figure 6. S21 versus Frequency versus Temperature

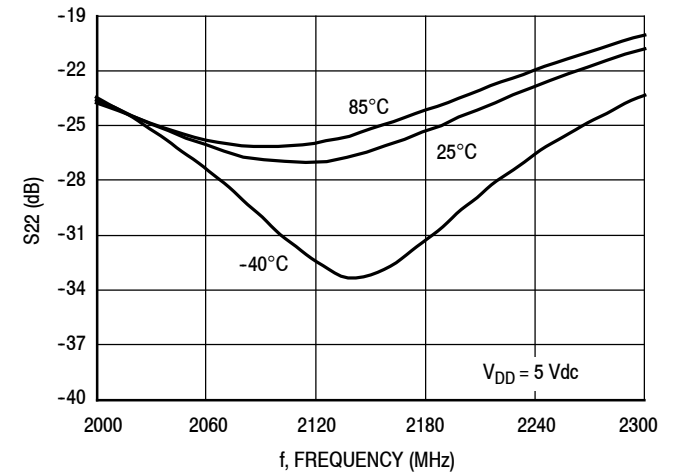

Figure 7. S22 versus Frequency versus Temperature

50 OHM TYPICAL CHARACTERISTICS: 2140 MHz

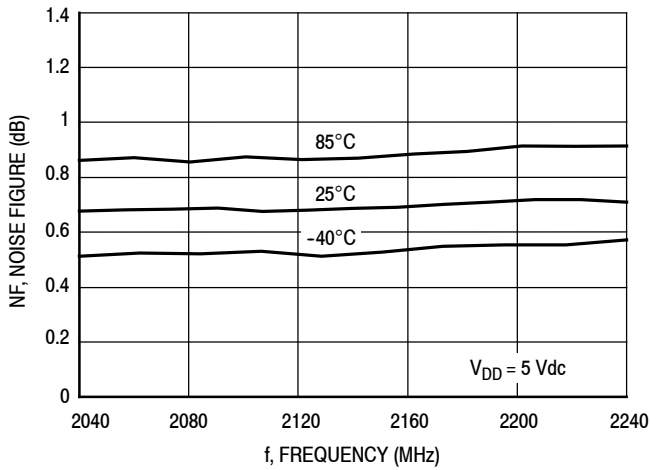

Figure 8. Noise Figure versus Frequency versus Temperature

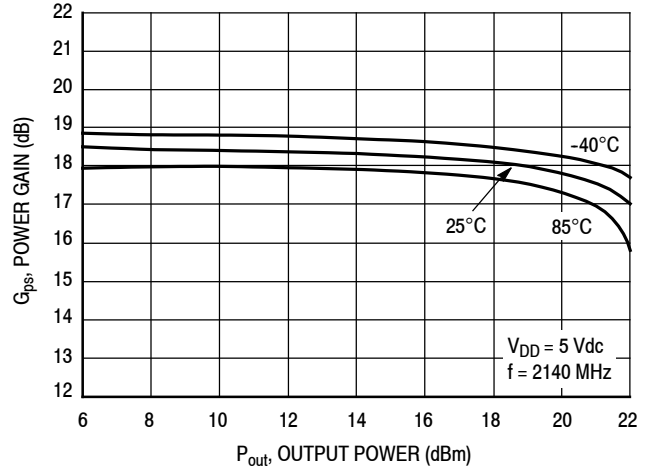

Figure 9. Power Gain versus Output Power versus Temperature, CW

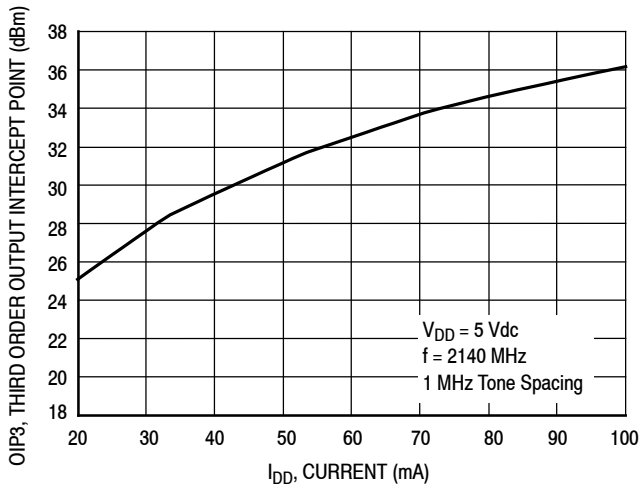

Figure 10. Third Order Output Intercept Point (Two-Tone) versus I_{DD} Current

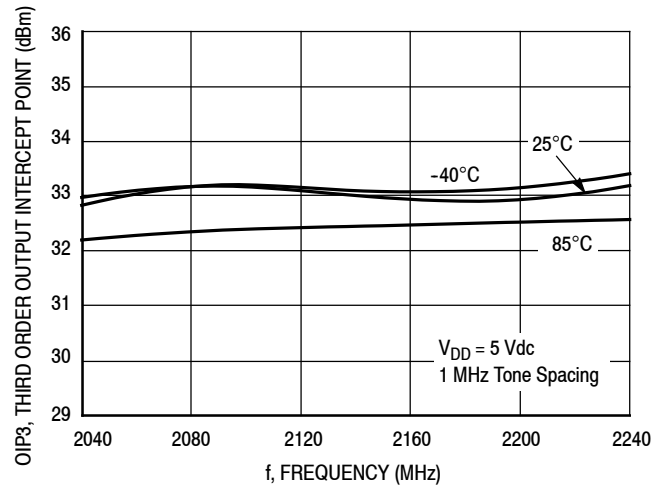

Figure 11. Third Order Output Intercept Point (Two-Tone) versus Frequency versus Temperature

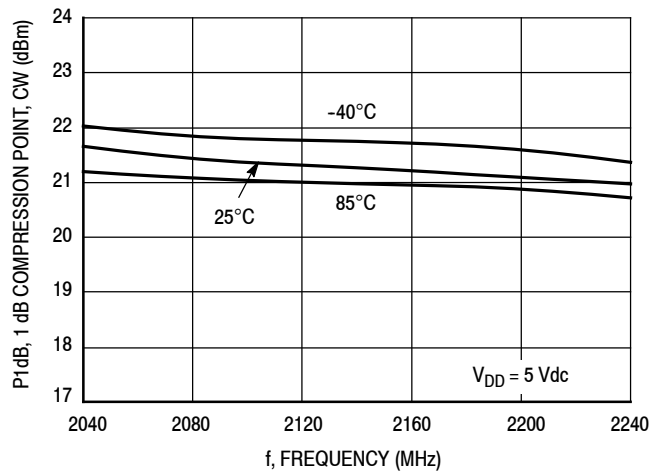
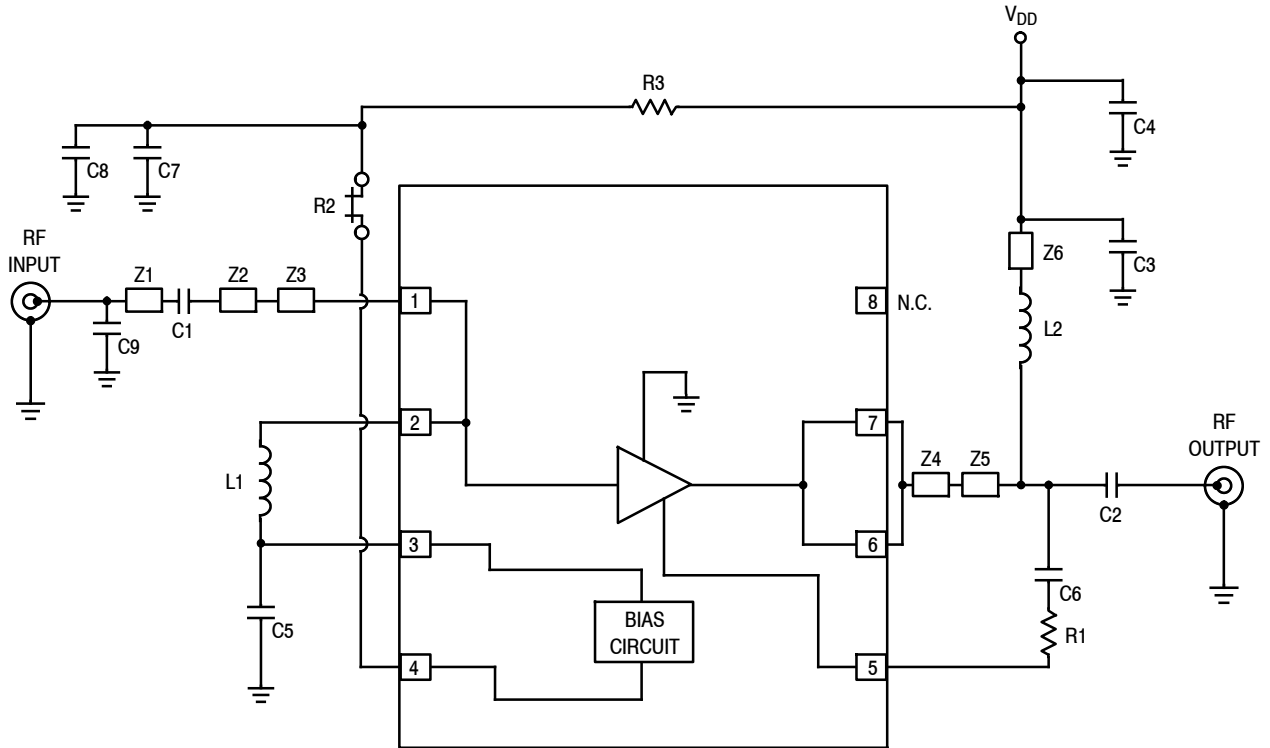

Figure 12. P1dB versus Frequency versus Temperature, CW

50 OHM APPLICATION CIRCUIT: 1800 MHz



Z1	0.080" x 0.021" Microstrip	Z4	0.020" x 0.031" Microstrip
Z2	0.218" x 0.021" Microstrip	Z5	0.038" x 0.021" Microstrip
Z3	0.044" x 0.011" Microstrip	Z6	0.021" x 0.080" Microstrip

Figure 13. MML20211HT1 Test Circuit Schematic

Table 9. MML20211HT1 Test Circuit Component Designations and Values

Part	Description	Part Number	Manufacturer
C1, C5	18 pF Chip Capacitors	GJM1555C1H180JB01D	Murata
C2, C3, C6, C7	18 pF Chip Capacitors	GRM1555C1H180JA01D	Murata
C4, C8	0.1 μ F Chip Capacitors	GRM155R61A104KA01D	Murata
C9	0.7 pF Chip Capacitor	GJM1555C1HR70BB01D	Murata
L1	3.6 nH Chip Inductor	0402HP-3N6XGL	Coilcraft
L2	4.7 nH Chip Inductor	0402CS-4N7	Coilcraft
R1	180 Ω , 1/16 W Chip Resistor	RC0402FR-07180RL	Yageo
R2	0 Ω , 1 A Chip Resistor	ERJ2GE0R00X	Panasonic
R3	1.5 k Ω , 1/16 W Chip Resistor	RC0402FR-071K5L	Yageo
PCB	0.010", $\epsilon_r = 3.38$, Multilayer	IS680-3.38	Isola

50 OHM APPLICATION CIRCUIT: 1800 MHz

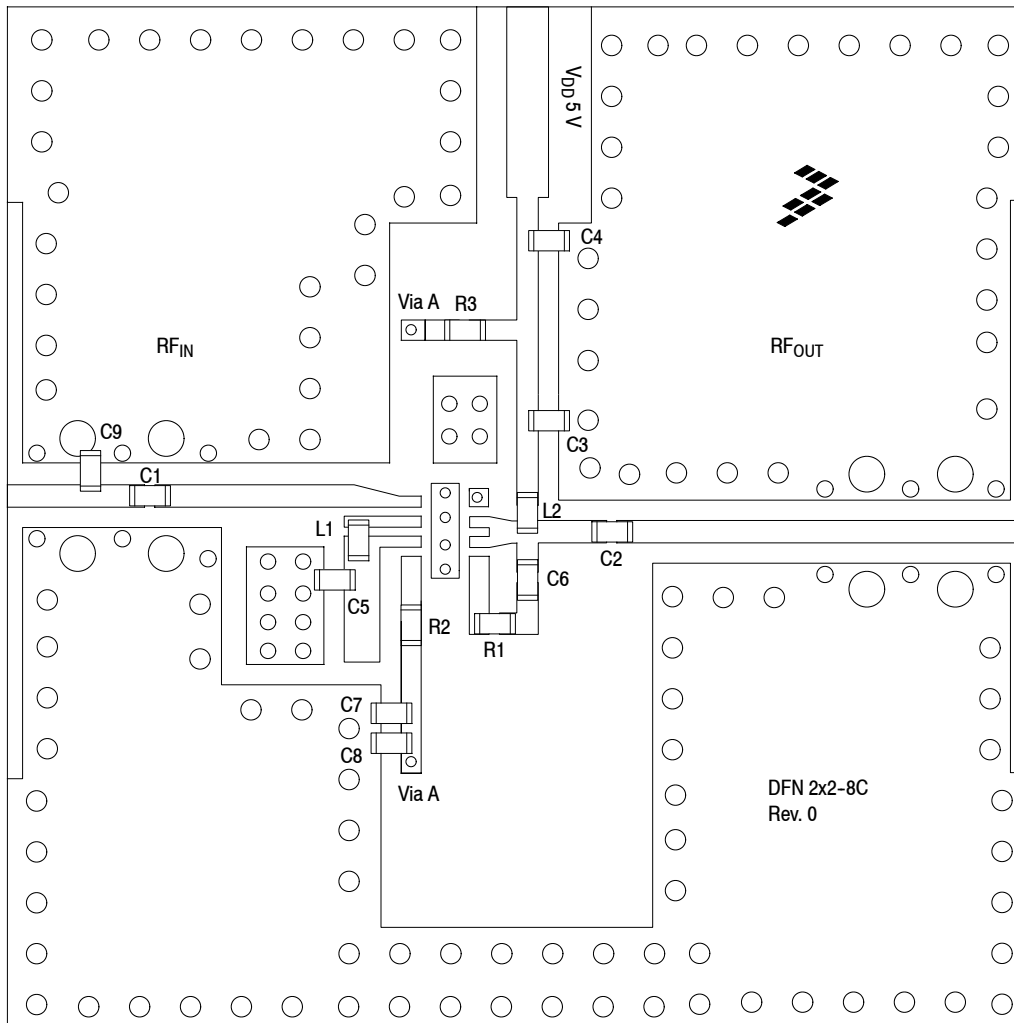

NOTE: To achieve optimal noise performance, it is critical that proper biasing, input matching, supply decoupling and grounding are employed.

Figure 14. MML2021HT1 Test Circuit Component Layout

Table 9. MML2021HT1 Test Circuit Component Designations and Values

Part	Description	Part Number	Manufacturer
C1, C5	18 pF Chip Capacitors	GJM1555C1H180JB01D	Murata
C2, C3, C6, C7	18 pF Chip Capacitors	GRM1555C1H180JA01D	Murata
C4, C8	0.1 μF Chip Capacitors	GRM155R61A104KA01D	Murata
C9	0.7 pF Chip Capacitor	GJM1555C1HR70BB01D	Murata
L1	3.6 nH Chip Inductor	0402HP-3N6XGL	Coilcraft
L2	4.7 nH Chip Inductor	0402CS-4N7	Coilcraft
R1	180 Ω, 1/16 W Chip Resistor	RC0402FR-07180RL	Yageo
R2	0 Ω, 1 A Chip Resistor	ERJ2GE0R00X	Panasonic
R3	1.5 kΩ, 1/16 W Chip Resistor	RC0402FR-071K5L	Yageo
PCB	0.010", ε _r = 3.38, Multilayer	IS680-3.38	Isola

(Test Circuit Component Designations and Values repeated for reference.)

50 OHM TYPICAL CHARACTERISTICS: 1800 MHz

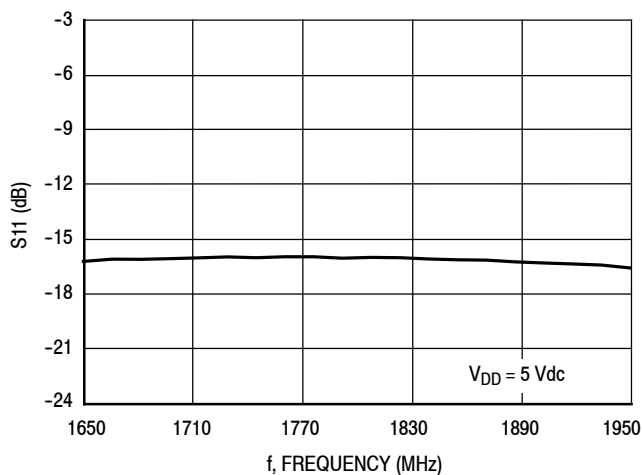

Figure 15. S11 versus Frequency

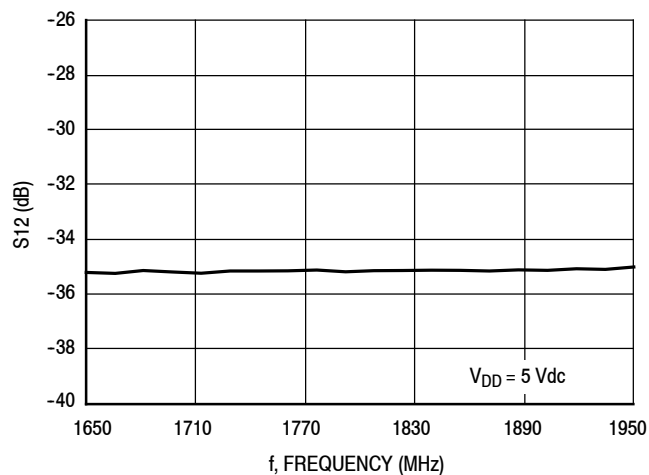

Figure 16. S12 versus Frequency

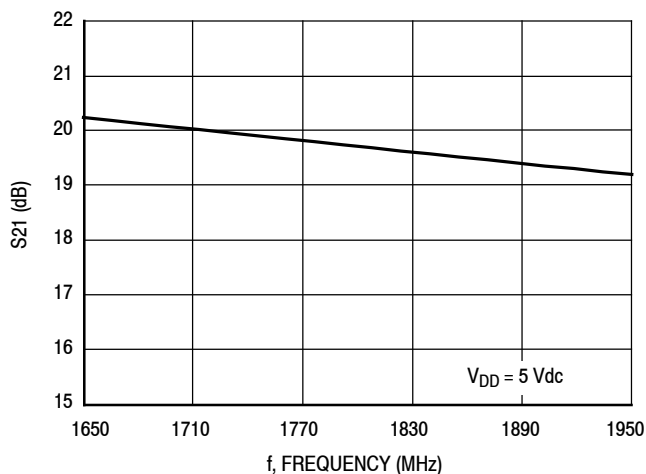

Figure 17. S21 versus Frequency

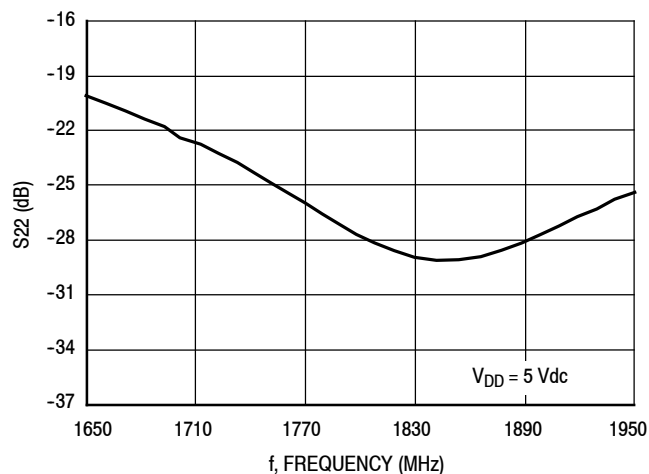

Figure 18. S22 versus Frequency

50 OHM TYPICAL CHARACTERISTICS: 1800 MHz

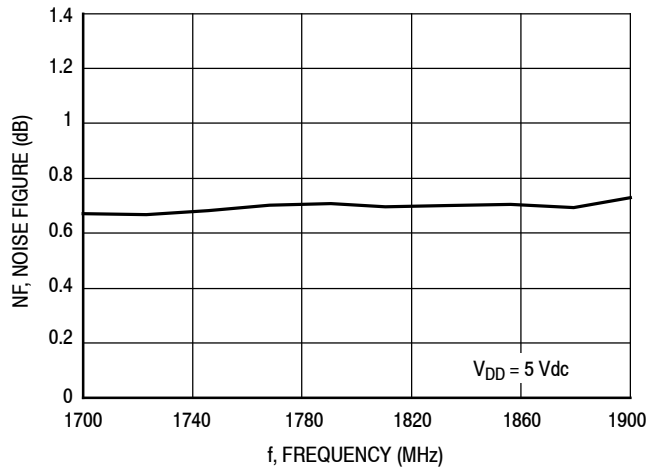

Figure 19. Noise Figure versus Frequency

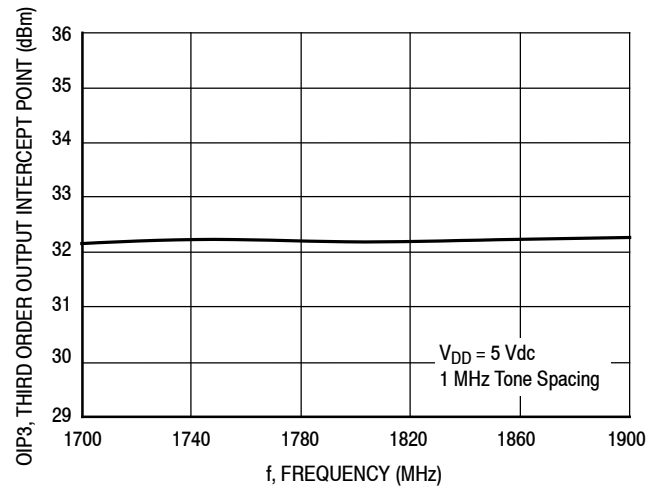
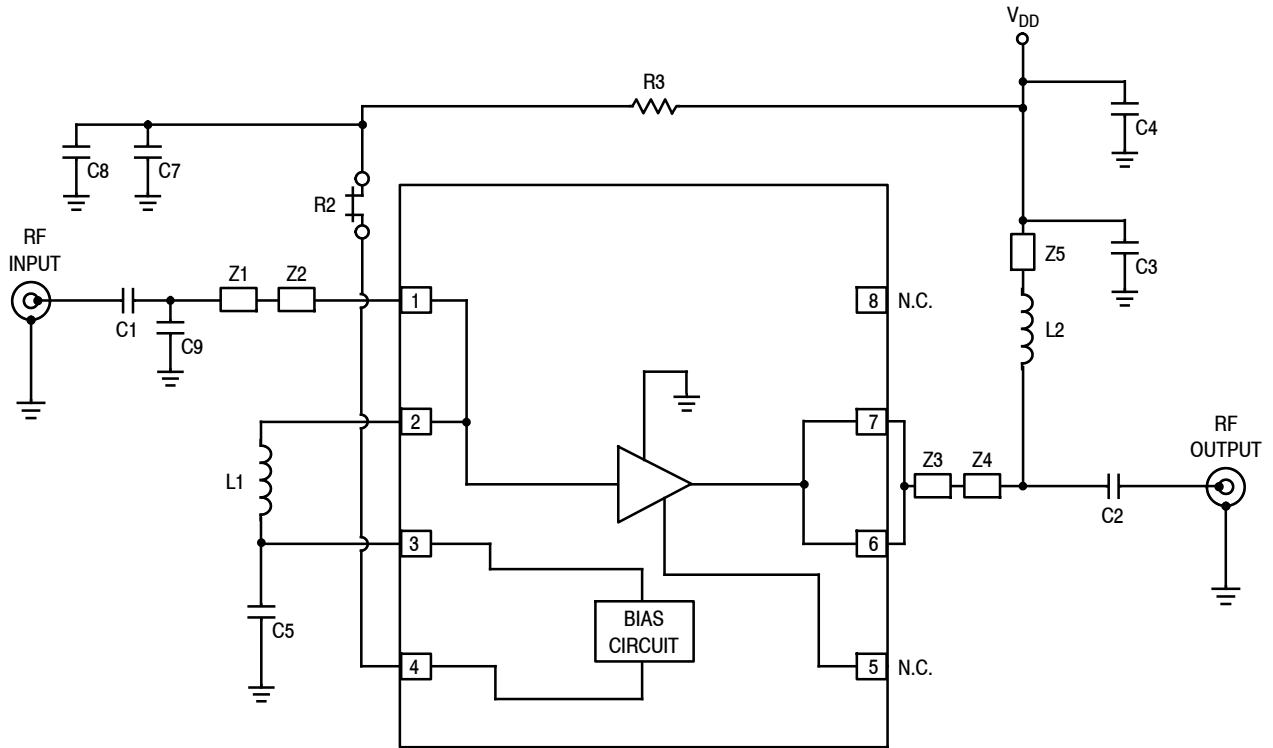

Figure 20. Third Order Output Intercept Point (Two-Tone) versus Frequency

50 OHM APPLICATION CIRCUIT: 2700 MHz



Z1	0.150" x 0.021" Microstrip	Z4	0.038" x 0.021" Microstrip
Z2	0.044" x 0.011" Microstrip	Z5	0.021" x 0.080" Microstrip
Z3	0.020" x 0.031" Microstrip		

Figure 21. MML20211HT1 Test Circuit Schematic

Table 10. MML20211HT1 Test Circuit Component Designations and Values

Part	Description	Part Number	Manufacturer
C1, C5	8.2 pF Chip Capacitors	GJM1555C1H8R2CB01	Murata
C2, C3, C7	8.2 pF Chip Capacitors	GRM1555C1H8R2DA01	Murata
C4, C8	0.1 μ F Chip Capacitors	GRM155R61A104KA01D	Murata
C6	Component Not Placed		
C9	0.8 pF Chip Capacitor	GJM1555C1HR80BB01D	Murata
L1, L2	2.2 nH Chip Inductors	0402CS-2N2	Coilcraft
R1	Component Not Placed		
R2	0 Ω , 1 A Chip Resistor	ERJ2GE0R00X	Panasonic
R3	1.5 k Ω , 1/16 W Chip Resistor	RC0402FR-071K5L	Yageo
PCB	0.010", $\epsilon_r = 3.38$, Multilayer	IS680-3.38	Isola

Note: Component numbers C6 and R1 are labeled on board but not placed.

50 OHM APPLICATION CIRCUIT: 2700 MHz

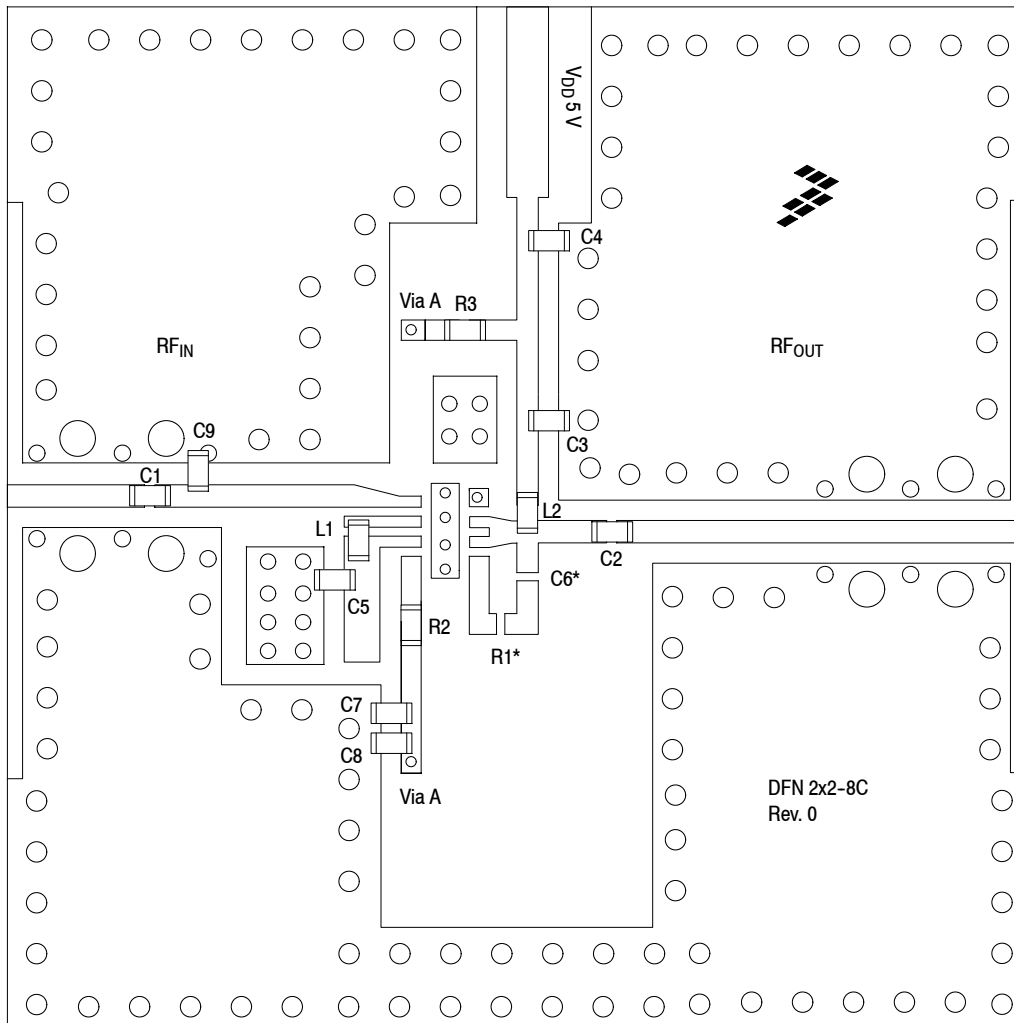

Note: Component numbers C6* and R1* are labeled on board but not placed.

NOTE: To achieve optimal noise performance, it is critical that proper biasing, input matching, supply decoupling and grounding are employed.

Figure 22. MML20211HT1 Test Circuit Component Layout

Table 10. MML20211HT1 Test Circuit Component Designations and Values

Part	Description	Part Number	Manufacturer
C1, C5	8.2 pF Chip Capacitors	GJM1555C1H8R2CB01	Murata
C2, C3, C7	8.2 pF Chip Capacitors	GRM1555C1H8R2DA01	Murata
C4, C8	0.1 μ F Chip Capacitors	GRM155R61A104KA01D	Murata
C6	Component Not Placed		
C9	0.8 pF Chip Capacitor	GJM1555C1HR80BB01D	Murata
L1, L2	2.2 nH Chip Inductors	0402CS-2N2	Coilcraft
R1	Component Not Placed		
R2	0 Ω , 1 A Chip Resistor	ERJ2GE0R00X	Panasonic
R3	1.5 k Ω , 1/16 W Chip Resistor	RC0402FR-071K5L	Yageo
PCB	0.010", $\epsilon_r = 3.38$, Multilayer	IS680-3.38	Isola

(Test Circuit Component Designations and Values repeated for reference.)

50 OHM TYPICAL CHARACTERISTICS: 2700 MHz

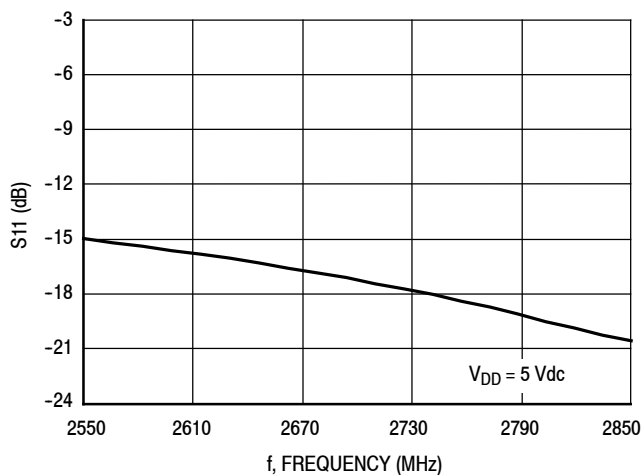

Figure 23. S11 versus Frequency

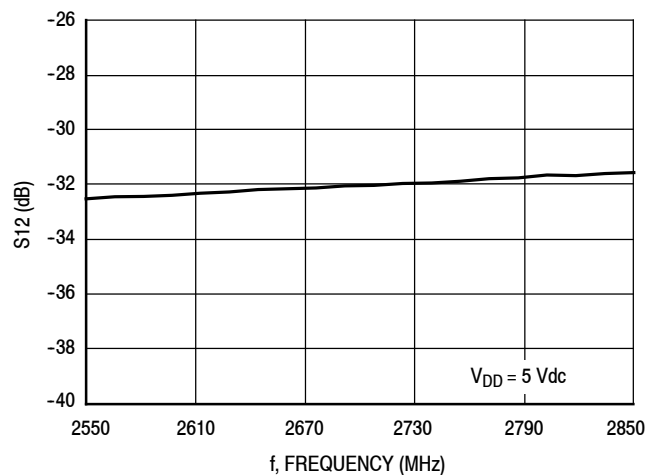

Figure 24. S12 versus Frequency

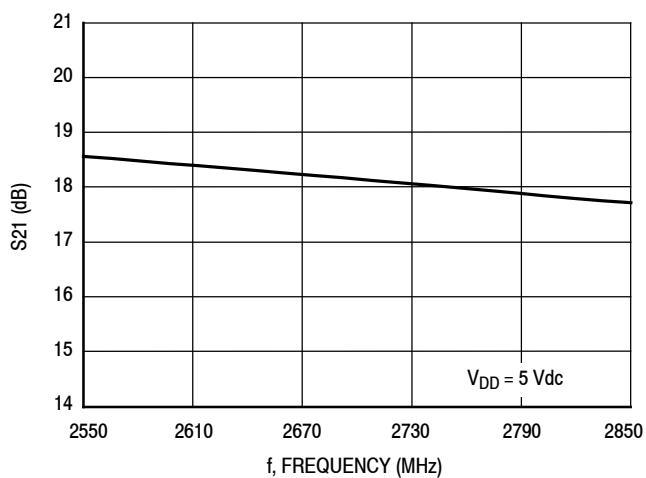

Figure 25. S21 versus Frequency

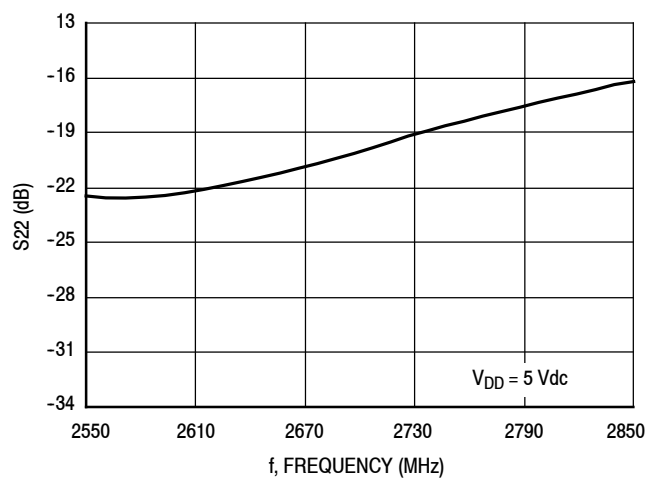

Figure 26. S22 versus Frequency

50 OHM TYPICAL CHARACTERISTICS: 2700 MHz

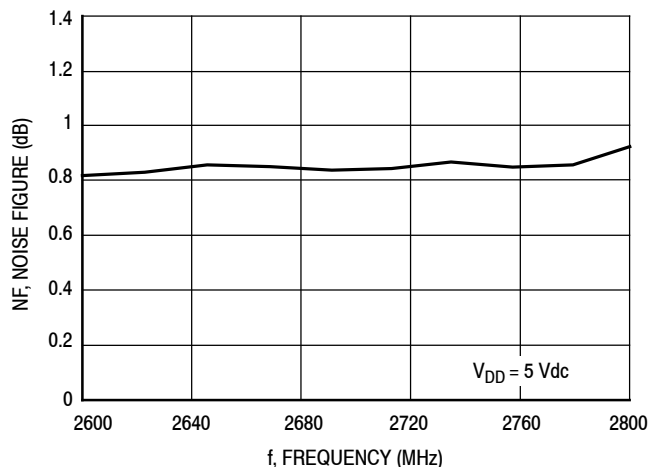

Figure 27. Noise Figure versus Frequency

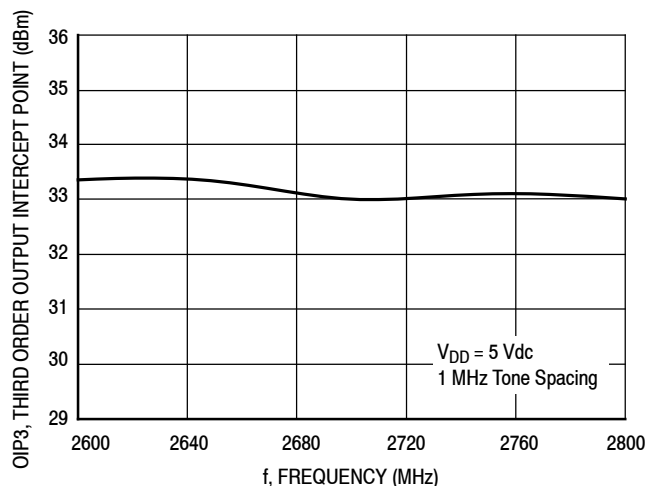

Figure 28. Third Order Output Intercept Point (Two-Tone) versus Frequency

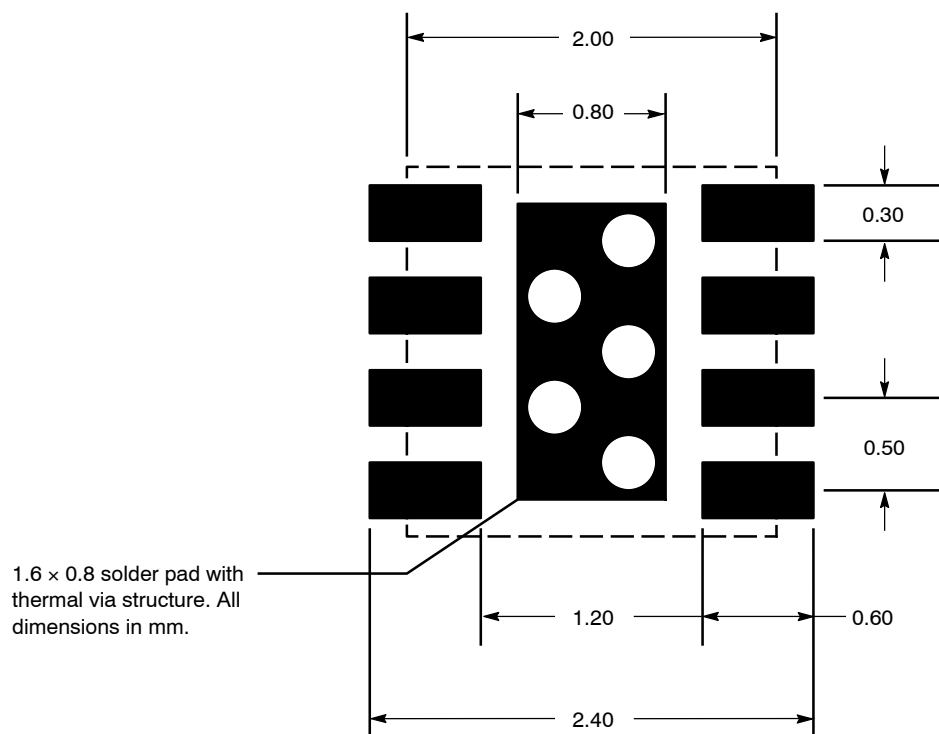

Figure 29. PCB Pad Layout for DFN 2 x 2

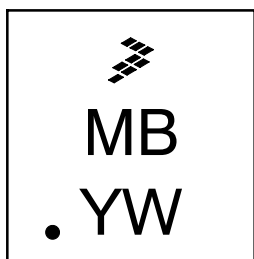
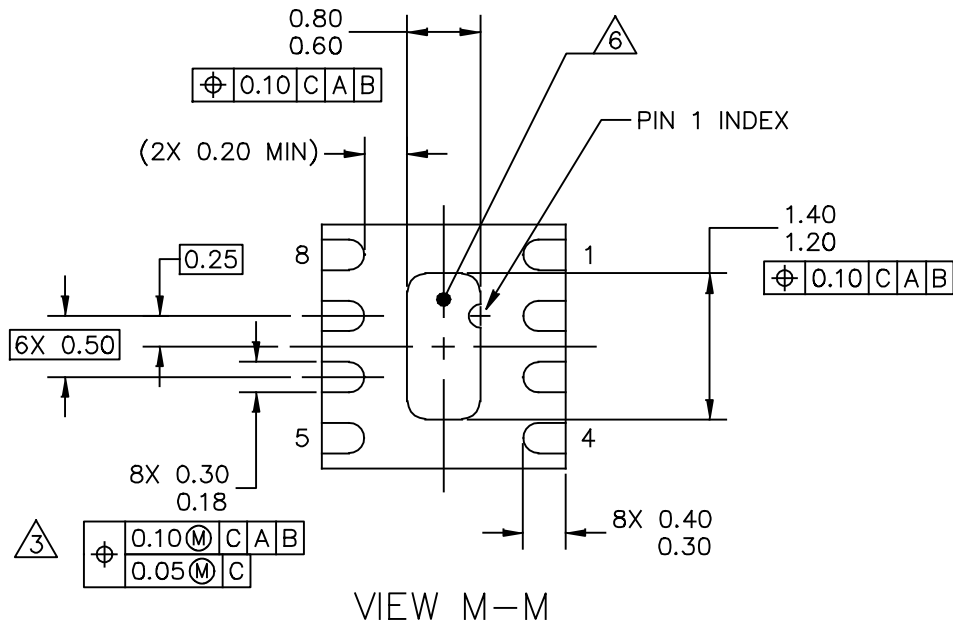
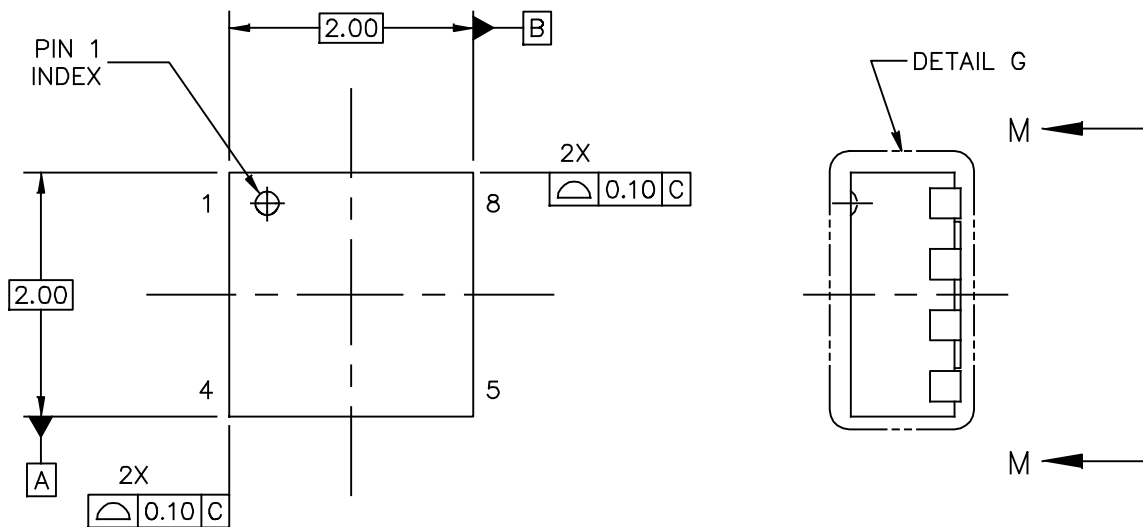
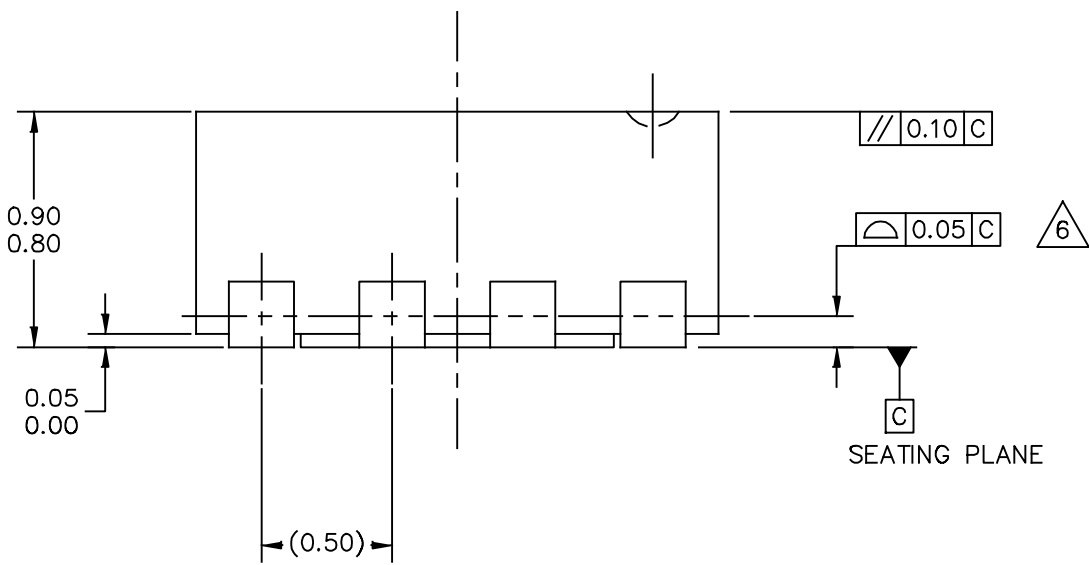

Figure 30. Product Marking

PACKAGE DIMENSIONS



© FREESCALE SEMICONDUCTOR, INC. ALL RIGHTS RESERVED.	MECHANICAL OUTLINE	PRINT VERSION NOT TO SCALE
TITLE: THERMALLY ENHANCED DUAL FLAT NON-LEADED PACKAGE (DFN) 8 TERMINAL, 0.5 PITCH (2 X 2 X 0.85)	DOCUMENT NO: 98ASA00228D	REV: 0
	CASE NUMBER: 2132-01	14 MAY 2010
	STANDARD: NON-JEDEC	



DETAIL G
VIEW ROTATED 90° CW

© FREESCALE SEMICONDUCTOR, INC. ALL RIGHTS RESERVED.	MECHANICAL OUTLINE	PRINT VERSION NOT TO SCALE	
TITLE: THERMALLY ENHANCED DUAL FLAT NON-LEADED PACKAGE (DFN) 8 TERMINAL, 0.5 PITCH (2 X 2 X 0.85)	DOCUMENT NO: 98ASA00228D	REV: 0	
	CASE NUMBER: 2132-01	14 MAY 2010	
	STANDARD: NON-JEDEC		

NOTES:

1. DIMENSIONING AND TOLERANCING PER ASME Y14.5 – 2009

2. ALL DIMENSIONS ARE IN MILLIMETERS.

3. THIS DIMENSION APPLIES TO METALLIZED TERMINAL AND IS MEASURED BETWEEN 0.15 AND 0.30mm FROM TERMINAL TIP. IF THE TERMINAL HAS THE OPTIONAL RADIUS ON THE OTHER END OF THE TERMINAL, THIS DIMENSION SHOULD NOT BE MEASURED IN THAT RADIUS AREA.

4. MAX. PACKAGE WARPAGE IS 0.05 mm.

5. MAXIMUM ALLOWABLE BURRS IS 0.076 mm IN ALL DIRECTIONS.

6. BILATERAL COPLANARITY ZONE APPLIES TO THE EXPOSED HEAT SINK SLUG AS WELL AS THE TERMINALS.

© FREESCALE SEMICONDUCTOR, INC. ALL RIGHTS RESERVED.	MECHANICAL OUTLINE	PRINT VERSION NOT TO SCALE	
TITLE: THERMALLY ENHANCED DUAL FLAT NON-LEADED PACKAGE (DFN) 8 TERMINAL, 0.5 PITCH (2 X 2 X 0.85)		DOCUMENT NO: 98ASA00228D	REV: 0
		CASE NUMBER: 2132-01	14 MAY 2010
		STANDARD: NON-JEDEC	

PRODUCT DOCUMENTATION, TOOLS AND SOFTWARE

Refer to the following resources to aid your design process.

Application Notes

- AN1955: Thermal Measurement Methodology of RF Power Amplifiers

Software

- .s2p File

Development Tools

- Printed Circuit Boards

For Software and Tools, do a Part Number search at <http://www.freescale.com>, and select the “Part Number” link. Go to Software & Tools on the part’s Product Summary page to download the respective tool.

FAILURE ANALYSIS

At this time, because of the physical characteristics of the part, failure analysis is limited to electrical signature analysis. In cases where Freescale is contractually obligated to perform failure analysis (FA) services, full FA may be performed by third party vendors with moderate success. For updates contact your local Freescale Sales Office.

REVISION HISTORY

The following table summarizes revisions to this document.

Revision	Date	Description
0	Aug. 2011	<ul style="list-style-type: none"> • Initial Release of Data Sheet
1	Sept. 2014	<ul style="list-style-type: none"> • Table 2, Maximum Ratings: updated Junction Temperature from 150°C to 175°C to reflect recent test results of the device, p. 1 • Table 6, ESD Protection Characteristics: removed the word “Minimum” after the ESD class rating. ESD ratings are characterized during new product development but are not 100% tested during production. ESD ratings provided in the data sheet are intended to be used as a guideline when handling ESD sensitive devices, p. 2 • Revised Failure Analysis information, p. 19

How to Reach Us:

Home Page:
freescale.com

Web Support:
freescale.com/support

Information in this document is provided solely to enable system and software implementers to use Freescale products. There are no express or implied copyright licenses granted hereunder to design or fabricate any integrated circuits based on the information in this document.

Freescale reserves the right to make changes without further notice to any products herein. Freescale makes no warranty, representation, or guarantee regarding the suitability of its products for any particular purpose, nor does Freescale assume any liability arising out of the application or use of any product or circuit, and specifically disclaims any and all liability, including without limitation consequential or incidental damages. "Typical" parameters that may be provided in Freescale data sheets and/or specifications can and do vary in different applications, and actual performance may vary over time. All operating parameters, including "typicals," must be validated for each customer application by customer's technical experts. Freescale does not convey any license under its patent rights nor the rights of others. Freescale sells products pursuant to standard terms and conditions of sale, which can be found at the following address: freescale.com/SalesTermsandConditions.

Freescale and the Freescale logo are trademarks of Freescale Semiconductor, Inc., Reg. U.S. Pat. & Tm. Off. All other product or service names are the property of their respective owners.

© 2011, 2014 Freescale Semiconductor, Inc.

Mouser Electronics

Authorized Distributor

Click to View Pricing, Inventory, Delivery & Lifecycle Information:

[NXP:](#)

[MML20211HT1](#)