

2-Wire High-Accuracy Temperature Sensor

Features

- Temperature-to-Digital Converter
- Accuracy with 12-bit Resolution:
 - $\pm 0.5^{\circ}\text{C}$ (typical) at $+25^{\circ}\text{C}$
 - $\pm 1^{\circ}\text{C}$ (maximum) from -10°C to $+85^{\circ}\text{C}$
 - $\pm 2^{\circ}\text{C}$ (maximum) from -10°C to $+125^{\circ}\text{C}$
 - $\pm 3^{\circ}\text{C}$ (maximum) from -55°C to $+125^{\circ}\text{C}$
- User-selectable Resolution: 9-12 bit
- Operating Voltage Range: 2.7V to 5.5V
- 2-wire Interface: I²C/SMBus Compatible
- Operating Current: 200 μA (typical)
- Shutdown Current: 1 μA (maximum)
- Power-saving One-shot Temperature Measurement
- Available Packages: SOT-23-5, MSOP-8, SOIC-8

Typical Applications

- Automotive Qualified
- Personal Computers and Servers
- Hard Disk Drives and Other PC Peripherals
- Entertainment Systems
- Office Equipment
- Data Communication Equipment
- Mobile Phones
- General Purpose Temperature Monitoring

Typical Application

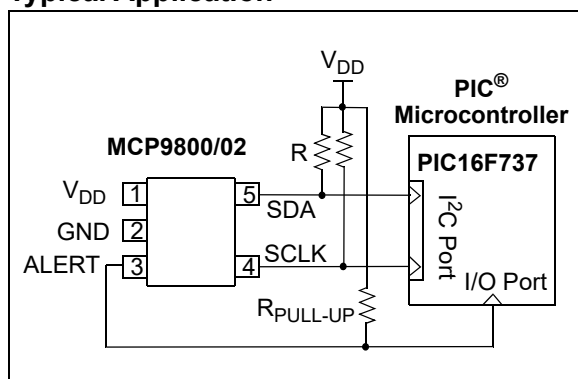

Description

Microchip Technology Inc.'s MCP9800/1/2/3 family of digital temperature sensors converts temperatures between -55°C and $+125^{\circ}\text{C}$ to a digital word. They provide an accuracy of $\pm 1^{\circ}\text{C}$ (maximum) from -10°C to $+85^{\circ}\text{C}$.

The MCP9800/1/2/3 family comes with user-programmable registers that provide flexibility for temperature sensing applications. The register settings allow user-selectable 9-bit to 12-bit temperature measurement resolution, configuration of the power-saving Shutdown and One-shot (single conversion on command while in Shutdown) modes and the specification of both temperature alert output and hysteresis limits. When the temperature changes beyond the specified limits, the MCP9800/1/2/3 outputs an alert signal. The user has the option of setting the alert output signal polarity as an active-low or active-high comparator output for thermostat operation, or as temperature event interrupt output for microprocessor-based systems.

This sensor has an industry standard 2-wire, I²C/SMBus compatible serial interface, allowing up to eight devices to be controlled in a single serial bus. These features make the MCP9800/1/2/3 ideal for sophisticated multi-zone temperature-monitoring applications.

Package Types

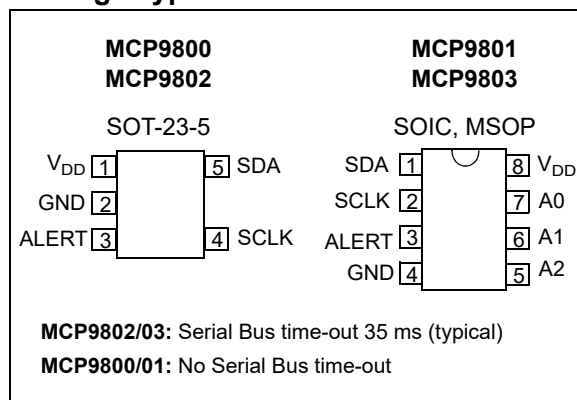

MCP9800/1/2/3

1.0 ELECTRICAL CHARACTERISTICS

Absolute Maximum Ratings †

V _{DD}	6.0V
Voltage at all Input/Output pins	GND – 0.3V to 5.5V
Storage temperature	-65°C to +150°C
Ambient temp. with power applied	-55°C to +125°C
Junction Temperature (T _J).....	150°C
ESD protection on all pins (HBM:MM).....	(4 kV:400V)
Latch-Up Current at each pin	±200 mA

†**Notice:** Stresses above those listed under “Maximum ratings” may cause permanent damage to the device. This is a stress rating only and functional operation of the device at those or any other conditions above those indicated in the operational listings of this specification is not implied. Exposure to maximum rating conditions for extended periods may affect device reliability.

DC CHARACTERISTICS

Electrical Specifications: Unless otherwise indicated, V _{DD} = 2.7V to 5.5V, GND = Ground, and T _A = -55°C to +125°C.						
Parameters	Sym	Min	Typ	Max	Unit	Conditions
Power Supply						
Operating Voltage Range	V _{DD}	2.7	—	5.5	V	
Operating Current	I _{DD}	—	200	400	μA	Continuous Operation
Shutdown Current	I _{SHDN}	—	0.1	1	μA	Shutdown mode
Power-on-Reset Threshold (POR)	V _{POR}	—	1.7	—	V	V _{DD} falling edge
Line Regulation	Δ°C/ΔV	—	0.2	—	°C/V	V _{DD} = 2.7V to 5.5V
Temperature Sensor Accuracy						
Accuracy with 12-bit Resolution:						
T _A = +25°C	T _{ACY}	—	±0.5	—	°C	V _{DD} = 3.3V
-10°C < T _A ≤ +85°C	T _{ACY}	-1.0	—	+1.0	°C	V _{DD} = 3.3V
-10°C < T _A ≤ +125°C	T _{ACY}	-2.0	—	+2.0	°C	V _{DD} = 3.3V
-55°C < T _A ≤ +125°C	T _{ACY}	-3.0	—	+3.0	°C	V _{DD} = 3.3V
Internal ΣΔ ADC						
Conversion Time:						
9-bit Resolution	t _{CONV}	—	30	75	ms	33 samples/sec (typical)
10-bit Resolution	t _{CONV}	—	60	150	ms	17 samples/sec (typical)
11-bit Resolution	t _{CONV}	—	120	300	ms	8 samples/sec (typical)
12-bit Resolution	t _{CONV}	—	240	600	ms	4 samples/sec (typical)
Alert Output (Open-drain)						
High-level Current	I _{OH}	—	—	1	μA	V _{OH} = 5V
Low-level Voltage	V _{OL}	—	—	0.4	V	I _{OL} = 3 mA
Thermal Response						
Response Time	t _{RES}	—	1.4	—	s	Time to 63% (89°C) 27°C (Air) to 125°C (oil bath)

DIGITAL INPUT/OUTPUT PIN CHARACTERISTICS

Electrical Specifications: Unless otherwise indicated, $V_{DD} = 2.7V$ to $5.5V$, GND = Ground and $T_A = -55^{\circ}C$ to $+125^{\circ}C$.

Parameters	Sym	Min	Typ	Max	Units	Conditions
Serial Input/Output (SCLK, SDA, A0, A1, A2)						
Input						
High-level Voltage	V_{IH}	$0.7 V_{DD}$	—	—	V	
Low-level Voltage	V_{IL}	—	—	$0.3 V_{DD}$	V	
Input Current	I_{IN}	-1	—	+1	μA	
Output (SDA)						
Low-level Voltage	V_{OL}	—	—	0.4	V	$I_{OL} = 3 mA$
High-level Current	I_{OH}	—	—	1	μA	$V_{OH} = 5V$
Low-level Current	I_{OL}	6	—	—	mA	$V_{OL} = 0.6V$
Capacitance	C_{IN}	—	10	—	pF	
SDA and SCLK Inputs						
Hysteresis	V_{HYST}	$0.05 V_{DD}$	—	—	V	

Graphical Symbol Description

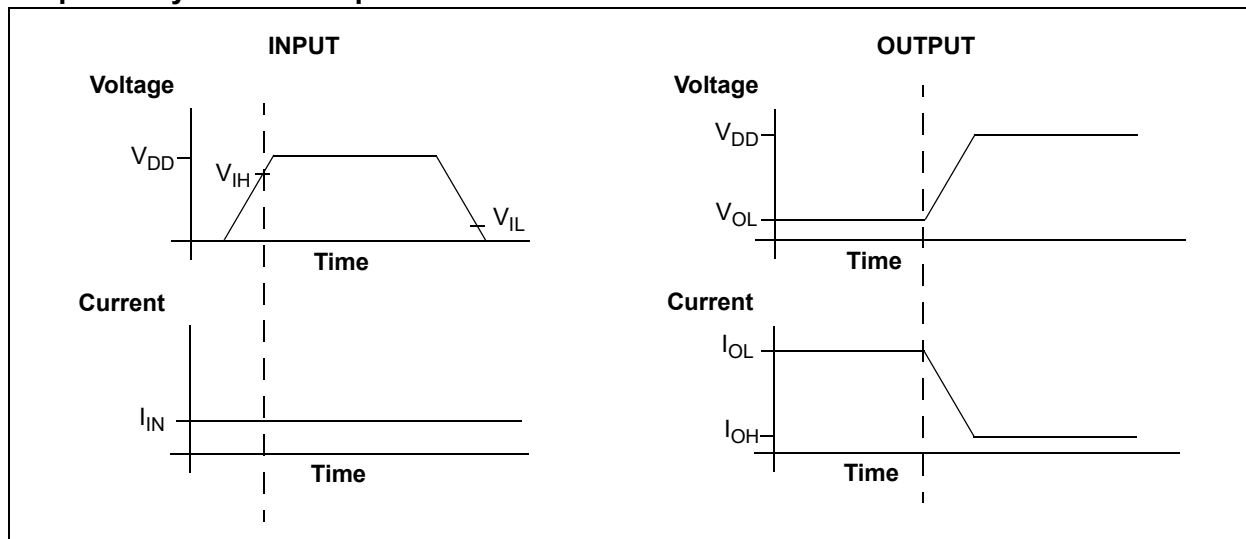

TEMPERATURE CHARACTERISTICS

Electrical Specifications: Unless otherwise indicated, $V_{DD} = +2.7V$ to $+5.5V$, GND = Ground.

Parameters	Sym	Min	Typ	Max	Units	Conditions
Temperature Ranges						
Specified Temperature Range	T_A	-55	—	+125	$^{\circ}C$	(Note 1)
Operating Temperature Range	T_A	-55	—	+125	$^{\circ}C$	
Storage Temperature Range	T_A	-65	—	+150	$^{\circ}C$	
Thermal Package Resistances						
Thermal Resistance, 5L-SOT23	θ_{JA}	—	256	—	$^{\circ}C/W$	
Thermal Resistance, 8L-SOIC	θ_{JA}	—	163	—	$^{\circ}C/W$	
Thermal Resistance, 8L-MSOP	θ_{JA}	—	206	—	$^{\circ}C/W$	

Note 1: Operation in this range must not cause T_J to exceed Maximum Junction Temperature ($+150^{\circ}C$).

MCP9800/1/2/3

SERIAL INTERFACE TIMING SPECIFICATIONS

Electrical Specifications: Unless otherwise indicated, $V_{DD} = 2.7V$ to $5.5V$, $GND = \text{Ground}$, $-55^{\circ}C < T_A < +125^{\circ}C$, $C_L = 80 \text{ pF}$, and all limits measured to 50% point.

Parameters	Sym	Min	Typ	Max	Units	Conditions
2-Wire I²C™/SMBus Compatible Interface						
Serial Port Frequency	f_{SC}	0	—	400	kHz	I ² C MCP9800/01
	f_{SC}	10	—	400	kHz	SMBus MCP9802/03
Clock Period	t_{SC}	2.5	—	—	μs	
Low Clock	t_{LOW}	1.3	—	—	μs	
High Clock	t_{HIGH}	0.6	—	—	μs	
Rise Time	t_R	20	—	300	ns	10% to 90% of V_{DD} (SCLK, SDA)
Fall Time	t_F	20	—	300	ns	90% to 10% of V_{DD} (SCLK, SDA)
Data Setup Before SCLK High	$t_{SU-DATA}$	0.1	—	—	μs	
Data Hold After SCLK Low	t_{H-DATA}	0	—	0.9	μs	
Start Condition Setup Time	$t_{SU-START}$	0.6	—	—	μs	
Start Condition Hold Time	$t_{H-START}$	0.6	—	—	μs	
Stop Condition Setup Time	$t_{SU-STOP}$	0.6	—	—	μs	
Bus Idle	t_{IDLE}	1.3	—	—	μs	
Time Out	t_{OUT}	25	35	50	ms	MCP9802/03 only

Timing Diagram

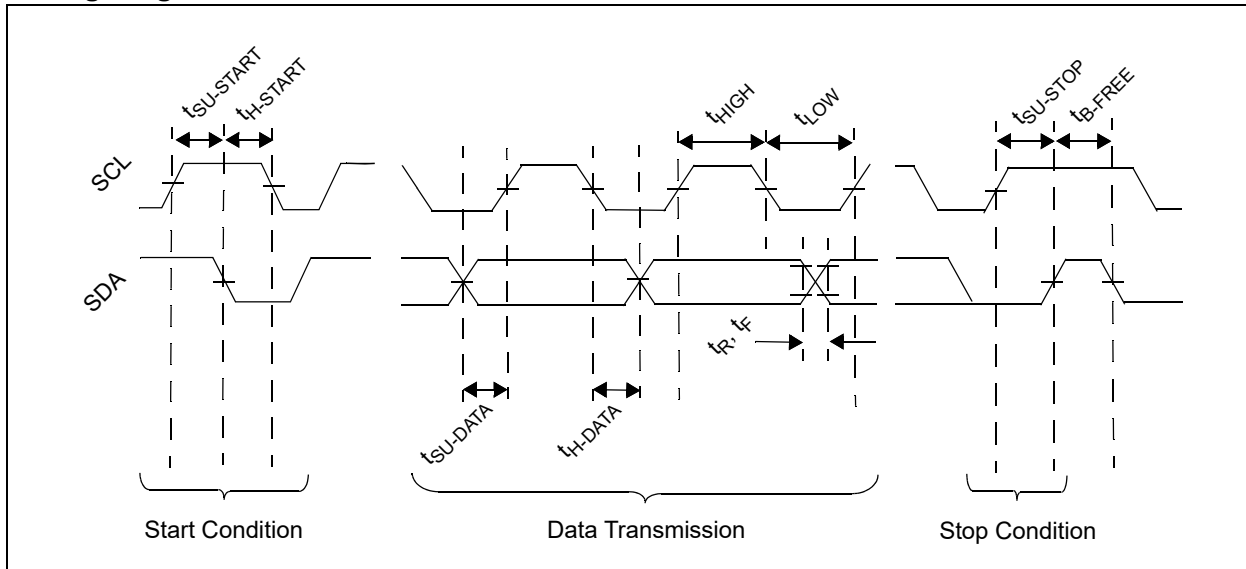

NOTES:

MCP9800/1/2/3

2.0 TYPICAL PERFORMANCE CURVES

Note: The graphs and tables provided following this note are a statistical summary based on a limited number of samples and are provided for informational purposes only. The performance characteristics listed herein are not tested or guaranteed. In some graphs or tables, the data presented may be outside the specified operating range (e.g., outside specified power supply range) and therefore, outside the warranted range.

Note: Unless otherwise noted: $V_{DD} = 2.7V$ to $5.5V$.

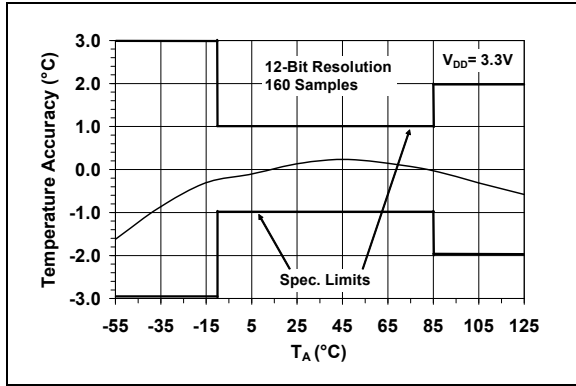

FIGURE 2-1: Average Temperature Accuracy vs. Ambient Temperature, $V_{DD} = 3.3V$.

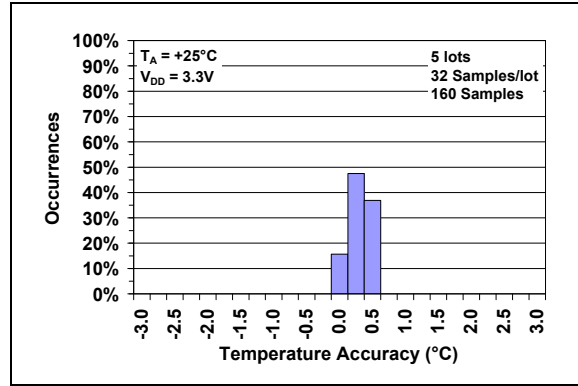

FIGURE 2-4: Temperature Accuracy Histogram, $T_A = +25^\circ C$.

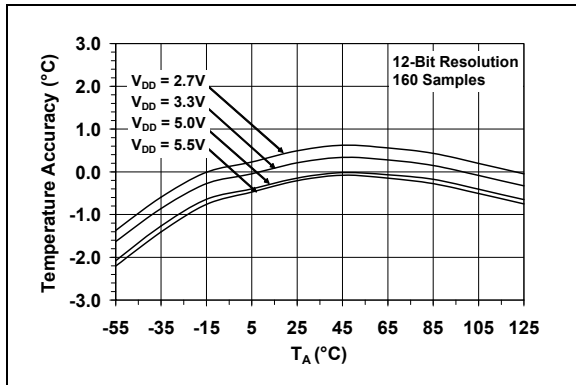

FIGURE 2-2: Average Temperature Accuracy vs. Ambient Temperature.

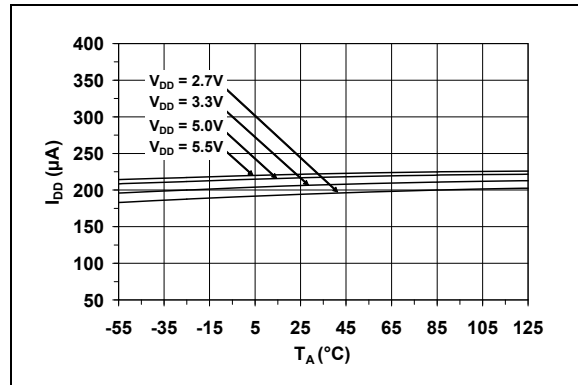

FIGURE 2-5: Supply Current vs. Ambient Temperature.

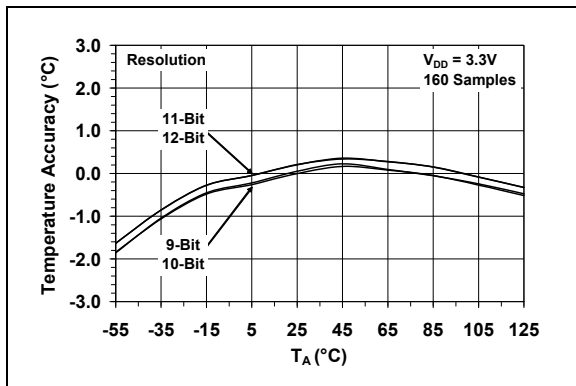

FIGURE 2-3: Average Temperature Accuracy vs. Ambient Temperature, $V_{DD} = 3.3V$.

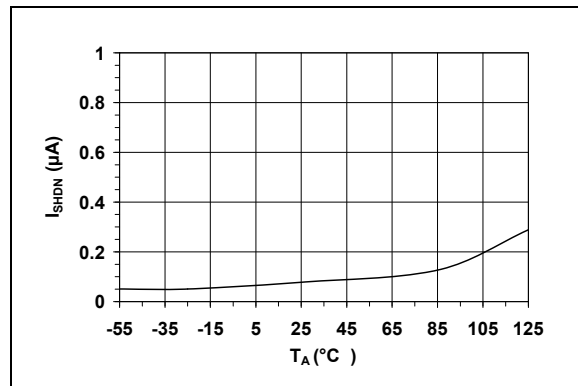

FIGURE 2-6: Shutdown Current vs. Ambient Temperature.

Note: Unless otherwise noted: $V_{DD} = 2.7V$ to $5.5V$.

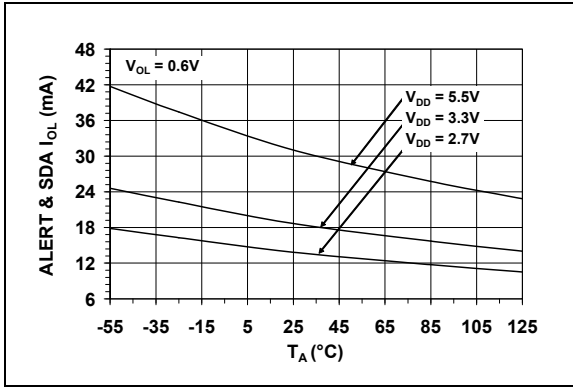

FIGURE 2-7: ALERT and SDA I_{OL} vs. Ambient Temperature.

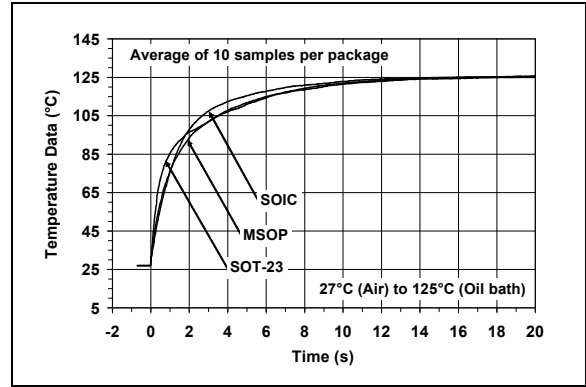

FIGURE 2-9: MCP980X Thermal Response vs. Time.

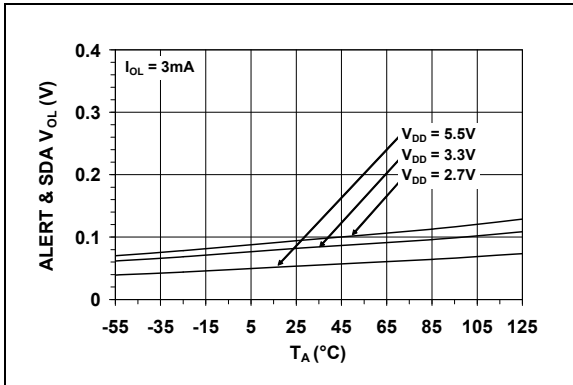

FIGURE 2-8: ALERT and SDA Output V_{OL} vs. Ambient Temperature.

MCP9800/1/2/3

3.0 PIN DESCRIPTION

The descriptions of the pins are listed in [Table 3-1](#).

TABLE 3-1: PIN FUNCTION TABLE

MCP9800 MCP9802 SOT-23-5	MCP9801 MCP9803 MSOP, SOIC	Symbol	Function
5	1	SDA	Bidirectional Serial Data
4	2	SCLK	Serial Clock Input
3	3	ALERT	Temperature Alert Output
2	4	GND	Ground
—	5	A2	Address Select Pin (bit 2)
—	6	A1	Address Select Pin (bit 1)
—	7	A0	Address Select Pin (bit 0)
1	8	V _{DD}	Power Supply Input

3.1 Serial Data Pin (SDA)

The SDA is a bidirectional input/output pin, used to serially transmit data to and from the host controller. This pin requires a pull-up resistor to output data.

3.2 Serial Clock Pin (SCLK)

The SCLK is a clock input pin. All communication and timing is relative to the signal on this pin. The clock is generated by the host controller on the bus.

3.3 Power Supply Input (V_{DD})

The V_{DD} pin is the power pin. The operating voltage, as specified in the DC electrical specification table, is applied on this pin.

3.4 Ground (GND)

The GND pin is the system ground pin.

3.5 ALERT Output

The MCP9800/1/2/3's ALERT pin is an open-drain output pin. The device outputs an alert signal when the ambient temperature goes beyond the user-programmed temperature limit.

3.6 Address Pins (A2, A1, A0)

These pins are device or client address input pins and are available only with the MCP9801/03. The device addresses for the MCP9800/02 are factory-set.

The address pins are the Least Significant bits (LSb) of the device address bits. The Most Significant bits (MSb) (A6, A5, A4, A3) are factory-set to <1001>. This is illustrated in [Table 3-2](#).

TABLE 3-2: CLIENT ADDRESS

Device	A6	A5	A4	A3	A2	A1	A0
MCP9800/02A0	1	0	0	1	0	0	0
MCP9800/02A1	1	0	0	1	0	0	1
MCP9800/02A2	1	0	0	1	0	1	0
MCP9800/02A3	1	0	0	1	0	1	1
MCP9800/02A4	1	0	0	1	1	0	0
MCP9800/02A5	1	0	0	1	1	0	1
MCP9800/02A6	1	0	0	1	1	1	0
MCP9800/02A7	1	0	0	1	1	1	1
MCP9801/03	1	0	0	1	X	X	X

Note: User-selectable address is shown by X.

NOTES:

MCP9800/1/2/3

4.0 SERIAL COMMUNICATION

4.1 2-Wire SMBus/Standard Mode I²C™ Protocol-Compatible Interface

The MCP9800/1/2/3 serial clock input (SCL) and the bidirectional serial data line (SDA) form a 2-wire bidirectional SMBus/Standard mode I²C compatible communication port (refer to the [Digital Input/Output Pin Characteristics Table](#) and [Serial Interface Timing Specifications Table](#)).

The following bus protocol has been defined:

TABLE 4-1: MCP9800 SERIAL BUS PROTOCOL DESCRIPTIONS

Term	Description
Host	The device that controls the serial bus, typically a microcontroller.
Client	The device addressed by the host, such as the MCP9800/1/2/3.
Transmitter	Device sending data to the bus.
Receiver	Device receiving data from the bus.
Start	A unique signal from host to initiate serial interface with a client.
Stop	A unique signal from the host to terminate serial interface from a client.
Read/Write	A read or write to the MCP9800/1/2/3 registers.
ACK	A receiver Acknowledges (ACK) the reception of each byte by polling the bus.
NAK	A receiver Not-Acknowledges (NAK) or releases the bus to show End-of-Data (EOD).
Busy	Communication is not possible because the bus is in use.
Not Busy	The bus is in the Idle state, both SDA and SCL remain high.
Data Valid	SDA must remain stable before SCL becomes high in order for a data bit to be considered valid. During normal data transfers, SDA only changes state while SCL is low.

4.1.1 DATA TRANSFER

Data transfers are initiated by a Start condition (Start), followed by a 7-bit device address and a read/write bit. An Acknowledge (ACK) from the client confirms the reception of each byte. Each access must be terminated by a Stop condition (Stop).

Repeated communication is initiated after t_{B-FREE} .

This device does not support sequential register read/write. Each register needs to be addressed using the Register Pointer.

This device supports the Receive Protocol. The register can be specified using the pointer for the initial read. Each repeated read or receive begins with a Start condition and address byte. The MCP9800/1/2/3 retains the previously selected register. Therefore, it outputs data from the previously-specified register (repeated pointer specification is not necessary).

4.1.2 HOST/CLIENT

The bus is controlled by a host device (typically a microcontroller) that controls the bus access and generates the Start and Stop conditions. The MCP9800/1/2/3 is a client device and does not control other devices in the bus. Both host and client devices can operate as either transmitter or receiver. However, the host device determines which mode is activated.

4.1.3 START/STOP CONDITION

A high-to-low transition of the SDA line (while SCL is high) is the Start condition. All data transfers must be preceded by a Start condition from the host. If a Start condition is generated during data transfer, the MCP9800/1/2/3 resets and accepts the new Start condition.

A low-to-high transition of the SDA line (while SCL is high) signifies a Stop condition. If a Stop condition is introduced during data transmission, the MCP9800/1/2/3 releases the bus. All data transfers are ended by a Stop condition from the host.

4.1.4 ADDRESS BYTE

Following the Start condition, the host must transmit an 8-bit address byte to the MCP9800/1/2/3. The address for the MCP9800 Temperature Sensor is '1001, A2, A1, A0' in binary, where the A2, A1 and A0 bits are set externally by connecting the corresponding pins to V_{DD} '1' or GND '0'. The 7-bit address transmitted in the serial bit stream must match the selected address for the MCP9800/1/2/3 to respond with an ACK. Bit 8 in the address byte is a read/write bit. Setting this bit to '1' commands a read operation, while '0' commands a write operation (see [Figure 4-1](#)).

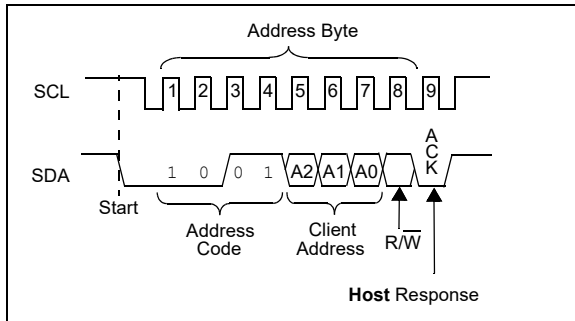

FIGURE 4-1: Device Addressing.

4.1.5 DATA VALID

After the Start condition, each bit of data in transmission needs to be settled for a time specified by $t_{SU-DATA}$ before SCL toggles from low-to-high (see [Section "Serial Interface Timing Specifications"](#)).

4.1.6 ACKNOWLEDGE (ACK)

Each receiving device, when addressed, is obliged to generate an ACK bit after the reception of each byte. The host device must generate an extra clock pulse for ACK to be recognized.

The acknowledging device pulls down the SDA line for $t_{SU-DATA}$ before the low-to-high transition of SCL from the host. SDA also needs to remain pulled down for t_{H-DATA} after a high-to-low transition of SCL.

During read, the host must signal an End-of-Data (EOD) to the client by not generating an ACK bit (NAK) once the last bit has been clocked out of the client. In this case, the client will leave the data line released to enable the host to generate the Stop condition.

MCP9800/1/2/3

5.0 FUNCTIONAL DESCRIPTION

The MCP9800/1/2/3 temperature sensor consists of a band-gap type temperature sensor, a $\Sigma\Delta$ Analog-to-Digital Converter (ADC), user-programmable registers and a 2-wire I²C protocol-compatible serial interface.

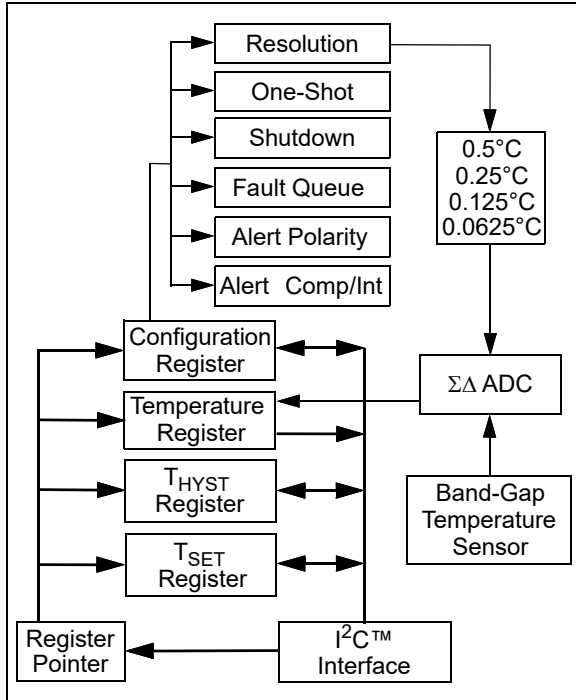

FIGURE 5-1: Functional Block Diagram.

5.1 Temperature Sensor

The MCP9800/1/2/3 uses the difference in the base-emitter voltage of a transistor while its collector current is changed from IC_1 to IC_2 . With this method, the ΔV_{BE} depends only on the ratio of the two currents and the ambient temperature, as shown in Equation 5-1.

EQUATION 5-1:

$$\Delta V_{BE} = \left(\frac{kT}{q} \right) \times \ln(IC_1/IC_2)$$

Where:

T = temperature in kelvin

ΔV_{BE} = change in diode base-emitter voltage

k = Boltzmann's constant

q = electron charge

IC_1 and IC_2 = currents with n:1 ratio

5.2 $\Sigma\Delta$ Analog-to-Digital Converter

A Sigma-Delta ADC is used to convert ΔV_{BE} to a digital word that corresponds to the transistor temperature. The converter has an adjustable resolution from 0.5°C (at 30 ms conversion time) to 0.0625°C (at 240 ms conversion time). Thus, it allows the user to make trade-offs between resolution and conversion time. Refer to Section 5.3.2, Sensor Configuration Register (CONFIG) and Section 5.3.4.7, SD ADC Resolution for details.

5.3 Registers

The MCP9800/1/2/3 has four registers that are user-accessible. These registers are specified as the Ambient Temperature (T_A) register, the Temperature Limit-set (T_{SET}) register, the Temperature Hysteresis (T_{HYST}) register and device Configuration (CONFIG) register.

The Ambient Temperature register is a read-only register and is used to access the ambient temperature data. The data from the ADC is loaded in parallel in the register. The Temperature Limit-set and Temperature Hysteresis registers are read/write registers that provide user-programmable temperature limits. If the ambient temperature drifts beyond the programmed limits, the MCP9800/1/2/3 outputs an alert signal using the ALERT pin (refer to [Section 5.3.4.3 “ALERT Output Configuration”](#)). The device Configuration register provides access for the user to configure the MCP9800/1/2/3's various features. These registers are described in further detail in the following sections.

The registers are accessed by sending Register Pointers to the MCP9800/1/2/3 using the serial interface. This is an 8-bit pointer. However, the two Least Significant bits (LSBs) are used as pointers and all other bits need to be cleared <0>. This device has additional registers that are reserved for test and calibration. If these registers are accessed, the device may not perform according to the specification. The pointer description is shown below.

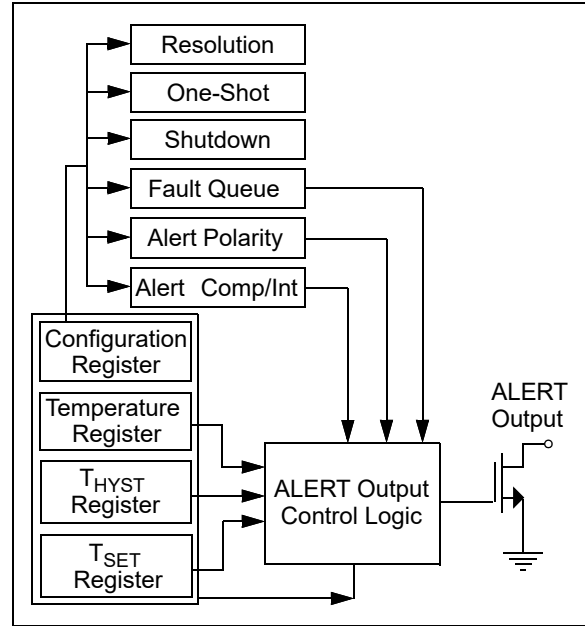

FIGURE 5-2: Register Block Diagram.

REGISTER 5-1: REGISTER POINTER

U-0	U-0	U-0	U-0	U-0	U-0	R/W-0	R/W-0	
0	0	0	0	0	0	P1	P0	
bit 7							bit 0	

Legend:

R = Readable bit W = Writable bit U = Unimplemented bit, read as '0'
 -n = Value at POR '1' = Bit is set '0' = Bit is cleared x = Bit is unknown

bit 7-2 **Unimplemented:** Read as '0'
 bit 1-0 **Px<1:0>:** Pointer bits
 00 =Temperature register (T_A)
 01 =Configuration register (CONFIG)
 10 =Temperature Hysteresis register (T_{HYST})
 11 =Temperature Limit-set register (T_{SET})

MCP9800/1/2/3

TABLE 5-1: BIT ASSIGNMENT SUMMARY FOR ALL REGISTERS

Register Pointer P1 P0	MSB/ LSB	Bit Assignment							
		7	6	5	4	3	2	1	0
Ambient Temperature Register (T_A)									
0 0	MSB	Sign	2 ⁶ °C	2 ⁵ °C	2 ⁴ °C	2 ³ °C	2 ² °C	2 ¹ °C	2 ⁰ °C
	LSB	2 ⁻¹ °C	2 ⁻² °C	2 ⁻³ °C	2 ⁻⁴ °C	0	0	0	0
Sensor Configuration Register (CONFIG)									
0 1	LSB	One-Shot	Resolution		Fault Queue		ALERT Polarity	COMP/INT	Shutdown
Temperature Hysteresis Register (T_{HYST})									
1 0	MSB	Sign	2 ⁶ °C	2 ⁵ °C	2 ⁴ °C	2 ³ °C	2 ² °C	2 ¹ °C	2 ⁰ °C
	LSB	2 ⁻¹ °C	0	0	0	0	0	0	0
Temperature Limit-Set Register (T_{SET})									
1 1	MSB	Sign	2 ⁶ °C	2 ⁵ °C	2 ⁴ °C	2 ³ °C	2 ² °C	2 ¹ °C	2 ⁰ °C
	LSB	2 ⁻¹ °C	0	0	0	0	0	0	0

5.3.1 AMBIENT TEMPERATURE REGISTER (T_A)

The MCP9800/1/2/3 has a 16-bit read-only Ambient Temperature register that contains 9-bit to 12-bit temperature data. (0.5°C to 0.0625°C resolutions, respectively). This data is formatted in two's complement. The bit assignments, as well as the corresponding resolution, is shown in the register assignment below.

The refresh rate of this register depends on the selected ADC resolution. It takes 30 ms (typical) for 9-bit data and 240 ms (typical) for 12-bit data. Since this register is double-buffered, the user can read the register while the MCP9800/1/2/3 performs Analog-to-Digital conversion in the background. The decimal code to ambient temperature conversion is shown in [Equation 5-2](#):

EQUATION 5-2:

$$T_A = \text{Code} \times 2^{-4}$$

Where:

T_A = Ambient Temperature (°C)
 Code = MCP9800 output in decimal

REGISTER 5-2: AMBIENT TEMPERATURE REGISTER (T_A) – ADDRESS <0000 0000>b

Upper Half:							
R-0	R-0	R-0	R-0	R-0	R-0	R-0	R-0
Sign	2 ⁶ °C	2 ⁵ °C	2 ⁴ °C	2 ³ °C	2 ² °C	2 ¹ °C	2 ⁰ °C
bit 15							bit 8

Lower Half:							
R-0	R-0	R-0	R-0	R-0	R-0	R-0	R-0
2 ⁻¹ °C/bit	2 ⁻² °C	2 ⁻³ °C	2 ⁻⁴ °C	0	0	0	0
bit 7							bit 0

Legend:			
R = Readable bit	W = Writable bit	U = Unimplemented bit, read as '0'	
-n = Value at POR	'1' = Bit is set	'0' = Bit is cleared	x = Bit is unknown

Note 1: When the 0.5°C, 0.25°C or 0.125°C resolutions are selected, bit 6, bit 7 or bit 8 will remain clear <0>, respectively.

MCP9800/1/2/3

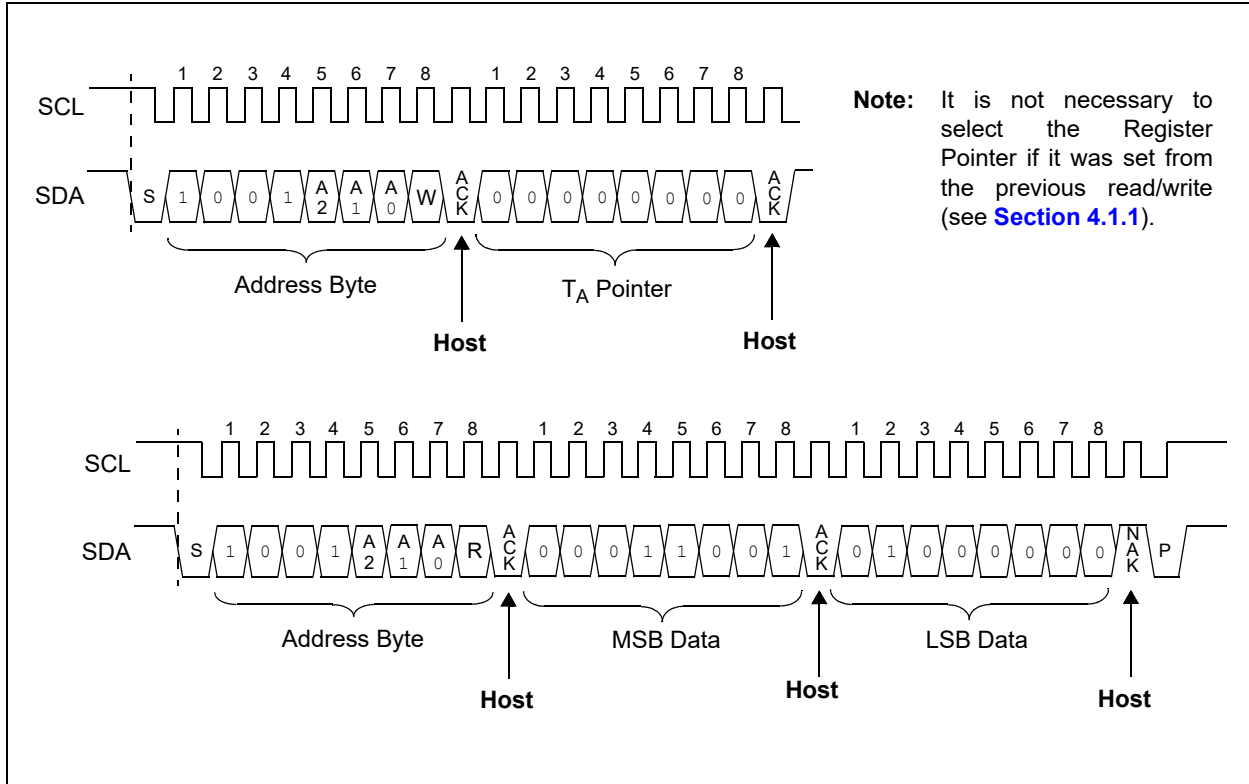

FIGURE 5-3: Timing Diagram for Reading +25.25°C Temperature from the T_A Register (see [Section 5.3.1 “Ambient Temperature Register \(TA\)”](#)).

5.3.2 SENSOR CONFIGURATION REGISTER (CONFIG)

The MCP9800/1/2/3 has an 8-bit read/write Configuration register that allows the user to select the different features. These features include shutdown, ALERT output select as comparator or interrupt output, ALERT output polarity, fault queue cycle, temperature measurement resolution and One-shot mode (single conversion while in shutdown). These functions are described in detail in the following sections.

REGISTER 5-3: CONFIGURATION REGISTER (CONFIG) – ADDRESS <0000 0001>b

R/W-0	R/W-0	R/W-0	R/W-0	R/W-0	R/W-0	R/W-0	R/W-0
One-Shot	Resolution		Fault Queue		ALERT Polarity	COMP/INT	Shutdown
bit 7							bit 0

Legend:

R = Readable bit	W = Writable bit	U = Unimplemented bit, read as '0'
-n = Value at POR	'1' = Bit is set	'0' = Bit is cleared
		x = Bit is unknown

- bit 7 **ONE-SHOT** bit
 - 1 = Enabled
 - 0 = Disabled (Power-up default)
- bit 5-6 **ΣΔ ADC RESOLUTION** bits
 - 00 =9 bit or 0.5°C (Power-up default)
 - 01 =10 bit or 0.25°C
 - 10 =11 bit or 0.125°C
 - 11 =12 bit or 0.0625°C
- bit 3-4 **FAULT QUEUE** bits
 - 00 =1 (Power-up default)
 - 01 =2
 - 10 =4
 - 11 = 6
- bit 2 **ALERT POLARITY** bit
 - 1 = Active-high
 - 0 = Active-low (Power-up default)
- bit 1 **COMP/INT** bit
 - 1 = Interrupt mode
 - 0 = Comparator mode (Power-up default)
- bit 0 **SHUTDOWN** bit
 - 1 = Enable
 - 0 = Disable (Power-up default)

MCP9800/1/2/3

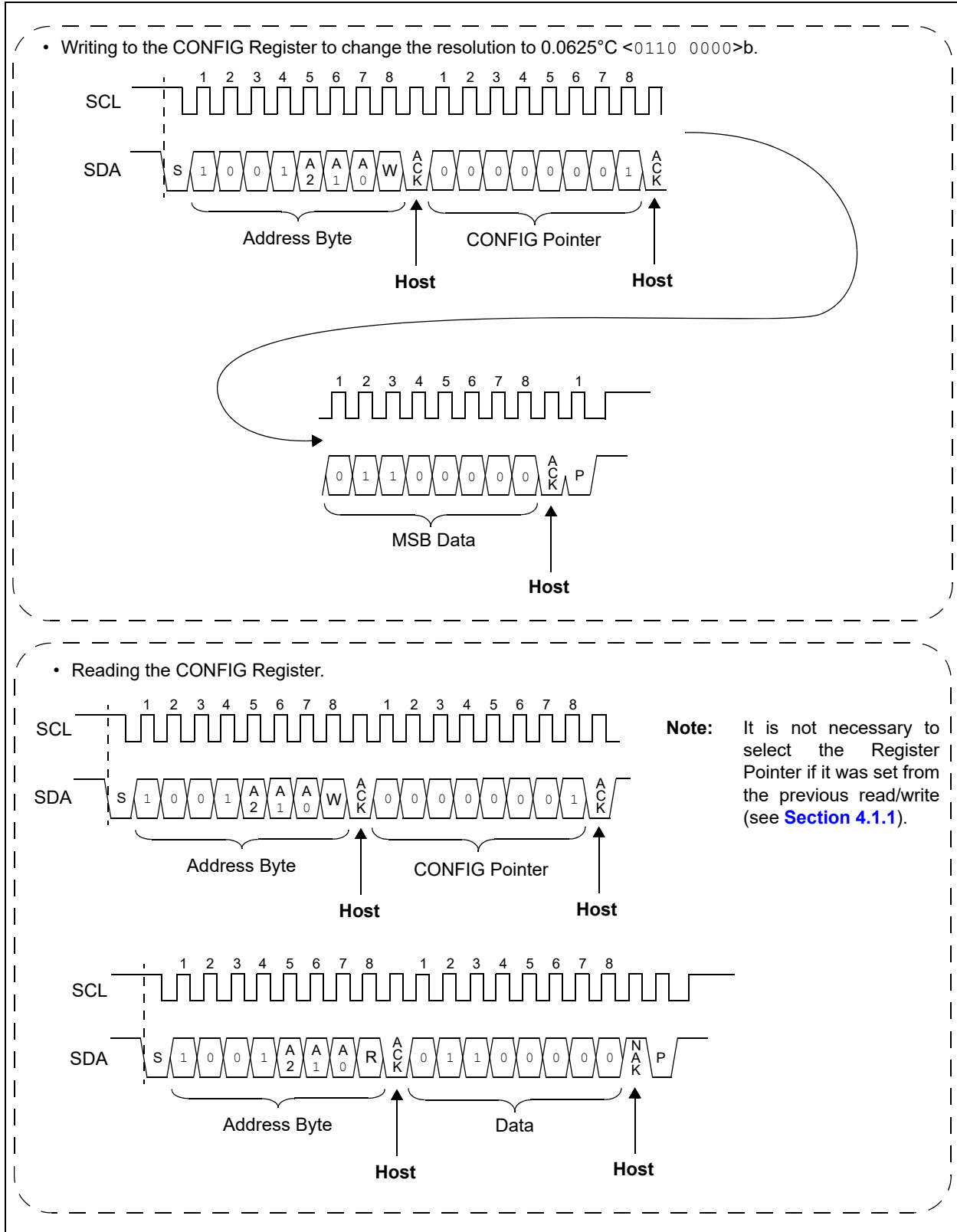

FIGURE 5-4: Timing Diagram for Writing and Reading from the Configuration Register (see [Section 5.3.2 “Sensor Configuration Register \(CONFIG\)”](#)).

5.3.3 TEMPERATURE HYSTERESIS REGISTER (T_{HYST})

The MCP9800/1/2/3 has a 16-bit read/write Temperature Hysteresis register that contains a 9-bit data in two's complement format. This register is used to set a hysteresis for the T_{SET} limit. Therefore, the data represents a minimum temperature limit. If the ambient temperature drifts below the specified limit, the MCP9800/1/2/3 asserts an alert output (refer to [Section 5.3.4.3 "ALERT Output Configuration"](#)).

This register uses the nine Most Significant bits (MSBs) and all other bits are "don't cares."

The power-up default value of T_{HYST} register is 75°C, or <0100 1011 0>b in binary.

REGISTER 5-4: TEMPERATURE HYSTERESIS REGISTER (T_{HYST}) – ADDRESS <0000 0010>b

Upper Half:							
R/W-0	R/W-1	R/W-0	R/W-0	R/W-1	R/W-0	R/W-1	R/W-1
Sign	2 ⁶ °C	2 ⁵ °C	2 ⁴ °C	2 ³ °C	2 ² °C	2 ¹ °C	2 ⁰ °C
bit 15							bit 8

Lower Half:							
R/W-0	R-0	R-0	R-0	R-0	R-0	R-0	R-0
2 ⁻¹ °C	0	0	0	0	0	0	0
bit 7							bit 0

Legend:			
R = Readable bit	W = Writable bit	U = Unimplemented bit, read as '0'	
-n = Value at POR	'1' = Bit is set	'0' = Bit is cleared	x = Bit is unknown

MCP9800/1/2/3

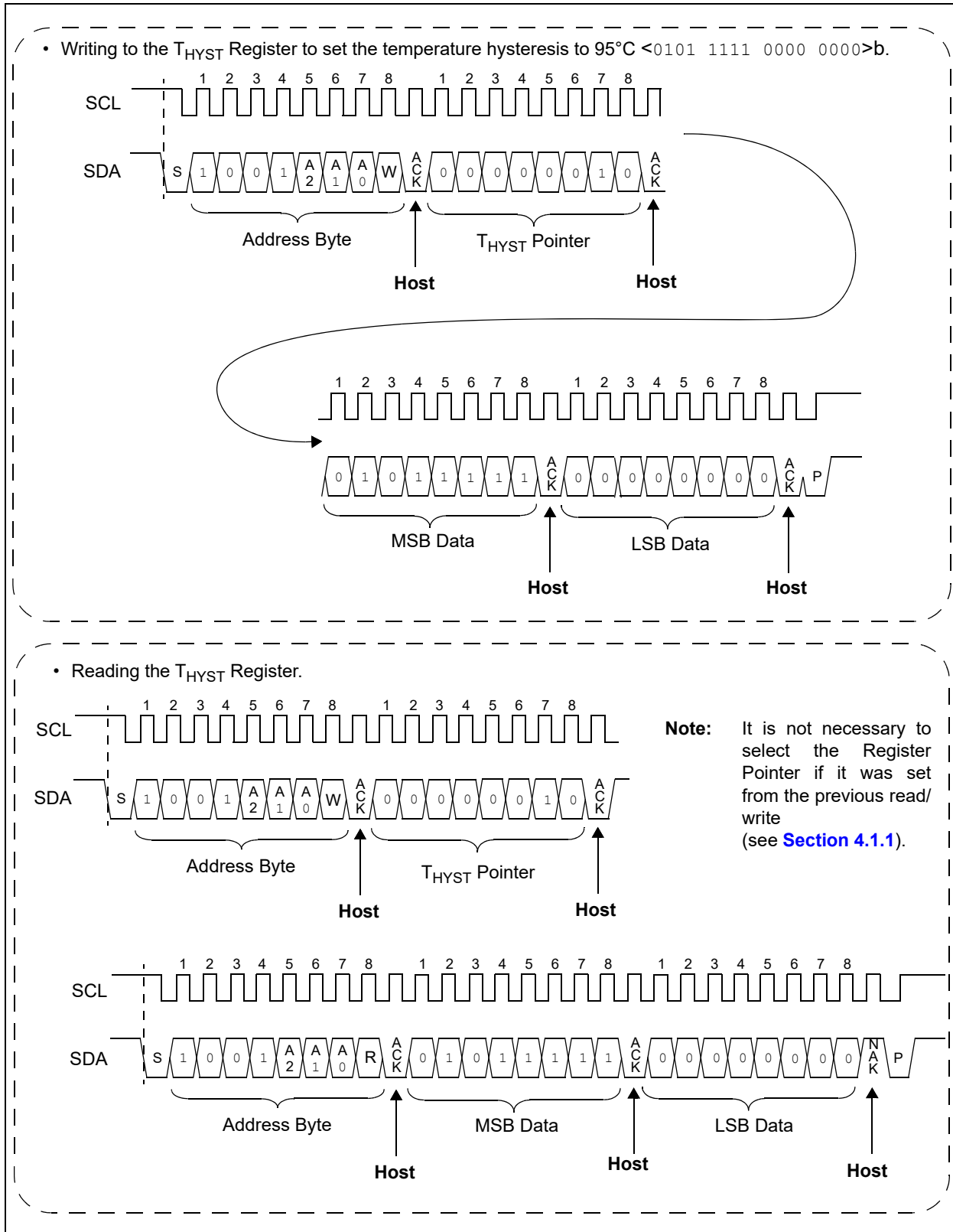

FIGURE 5-5: Timing Diagram for Writing and Reading from the Temperature Hysteresis Register (see [Section 5.3.3 “Temperature Hysteresis Register \(THYST\)”](#)).

5.3.4 TEMPERATURE LIMIT-SET REGISTER (T_{SET})

The MCP9800/1/2/3 has a 16-bit read/write Temperature Limit-Set register (T_{SET}) which contains a 9-bit data in two's complement format. This data represents a maximum temperature limit. If the ambient temperature exceeds this specified limit, the MCP9800/1/2/3 asserts an alert output (refer to [Section 5.3.4.3 "ALERT Output Configuration"](#)).

This register uses the nine Most Significant bits (MSBs) and all other bits are "don't cares."

The power-up default value of the T_{SET} register is 80°C, or <0101 0000 0>b in binary.

REGISTER 5-5: TEMPERATURE LIMIT-SET REGISTER (T_{SET}) – ADDRESS <0000 0011>b

Upper Half:							
R/W-0	R/W-1	R/W-0	R/W-1	R/W-0	R/W-0	R/W-0	R/W-0
Sign	2 ⁶ °C	2 ⁵ °C	2 ⁴ °C	2 ³ °C	2 ² °C	2 ¹ °C	2 ⁰ °C
bit 15							bit 8

Lower Half:							
R/W-0	R-0	R-0	R-0	R-0	R-0	R-0	R-0
2 ⁻¹ °C	0	0	0	0	0	0	0
bit 7							bit 0

Legend:			
R = Readable bit	W = Writable bit	U = Unimplemented bit, read as '0'	
-n = Value at POR	'1' = Bit is set	'0' = Bit is cleared	x = Bit is unknown

MCP9800/1/2/3

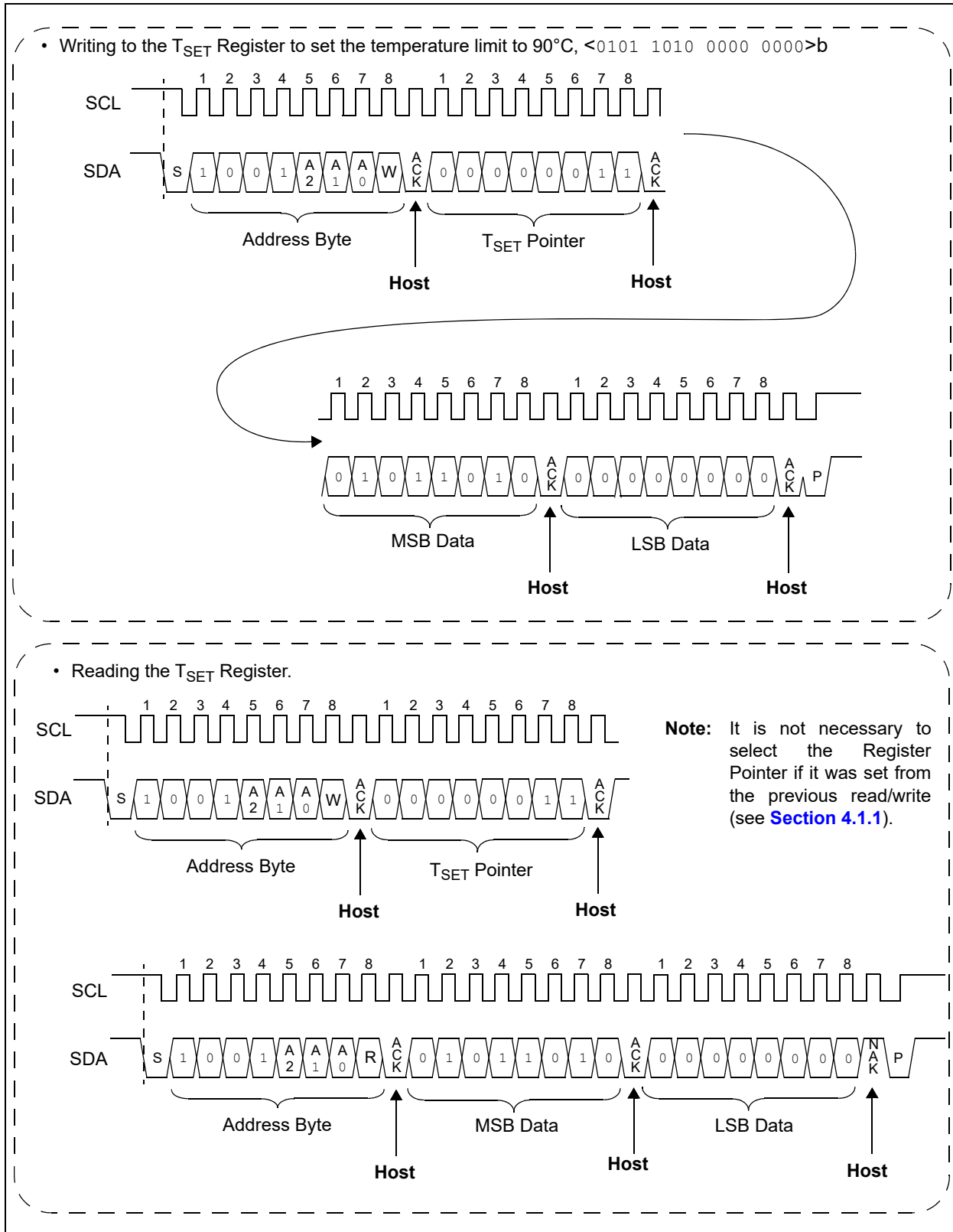

FIGURE 5-6: Timing Diagram for Writing and Reading from the Temperature Limit-set Register (see [Section 5.3.4 “Temperature Limit-Set Register \(TSET\)”](#)).

5.3.4.1 Shutdown Mode

The Shutdown mode disables all power-consuming activities (including temperature sampling operations) while leaving the serial interface active. The device consumes 2 μA (maximum) in this mode. It remains in this mode until the Configuration register is updated to enable continuous conversion or until power is recycled.

In Shutdown mode, the CONFIG, T_A , T_{SET} and T_{HYST} registers can be read or written to; however, the serial bus activity will increase the shutdown current.

5.3.4.2 One-Shot Mode

The MCP9800/1/2/3 can also be used in a One-shot mode that can be selected using bit 7 of the CONFIG register. The One-shot mode performs a single temperature measurement and returns to Shutdown mode. This mode is especially useful for low-power applications where temperature is measured upon command from a controller. For example, a 9-bit T_A in One-shot mode consumes 200 μA (typical) for 30 ms and 0.1 μA (typical) during shutdown.

To access this feature, the device needs to initially be in Shutdown mode. This is done by sending a byte to the CONFIG register with bit 0 set $\langle 1 \rangle$ and bit 7 cleared $\langle 0 \rangle$. Once the device is in Shutdown mode, the CONFIG register needs to be written to again, with bit 0 and bit 7 set $\langle 1 \rangle$. This begins the single conversion cycle of t_{CONV} , 30ms for 9-bit data. Once the conversion is completed, T_A is updated and bit 7 of CONFIG becomes cleared $\langle 0 \rangle$ by the MCP9800/1/2/3.

TABLE 5-2: SHUTDOWN AND ONE-SHOT MODE DESCRIPTION

Operational Mode	One-Shot (Bit 7)	Shutdown (Bit 0)
Continuous Conversion	0	0
Shutdown	0	1
Continuous Conversion (One-shot is ignored)	1	0
One-shot (Note 1)	1	1

Note 1: The shutdown command $\langle 01 \rangle$ needs to be programmed before sending a one-shot command $\langle 11 \rangle$.

5.3.4.3 ALERT Output Configuration

The ALERT output can be configured as either a comparator output or as Interrupt Output mode using bit 1 of CONFIG. The polarity can also be specified as an active-high or active-low using bit 2 of CONFIG. The following sections describe each output mode, while [Figure 5-7](#) gives a graphical description.

5.3.4.4 Comparator Mode

In Comparator mode, the ALERT output is asserted when T_A is greater than T_{SET} . The pin remains active until T_A is lower than T_{HYST} . The Comparator mode is useful for thermostat-type applications, such as turning on a cooling fan or triggering a system shutdown when the temperature exceeds a safe operating range.

In Comparator mode, if the device enters the Shutdown mode with asserted ALERT output, the output remains active during shutdown. The device must be operating in continuous conversion, with T_A below T_{HYST} , for the ALERT output to be deasserted.

5.3.4.5 Interrupt Mode

In Interrupt mode, the ALERT output is asserted when T_A is greater than T_{SET} . However, the output is deasserted when the user performs a read from any register. This mode is designed for interrupt-driven, microcontroller-based systems. The microcontroller receiving the interrupt will have to acknowledge the interrupt by reading any register from the MCP9800/1/2/3. This will clear the interrupt and the ALERT pin will become deasserted. When T_A drifts below T_{HYST} , the MCP9800/1/2/3 outputs another interrupt and the controller needs to read a register to deassert the ALERT output. Shutting down the device will also reset, or deassert, the ALERT output.

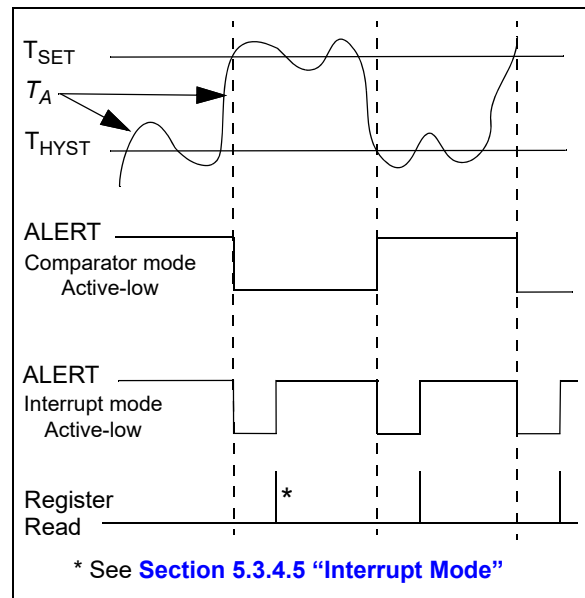

FIGURE 5-7: Alert Output.

MCP9800/1/2/3

5.3.4.6 Fault Queue

The fault queue feature can be used as a filter to lessen the probability of spurious activation of the ALERT pin. T_A must remain above T_{SET} for the consecutive number of conversion cycles selected using the Fault Queue bits. Bit 3 and bit 4 of CONFIG can be used to select up to six fault queue cycles. For example, if six fault queues are selected, T_A must be greater than T_{SET} for six consecutive conversions before ALERT is asserted as a comparator or an interrupt output.

This queue setting also applies for T_{HYST} . If six fault queues are selected, T_A must remain below T_{HYST} for six consecutive conversions before ALERT is deasserted (Comparator mode) or before another interrupt is asserted (Interrupt mode).

5.3.4.7 $\Sigma\Delta$ ADC Resolution

The MCP9800/1/2/3 provides access to select the ADC resolution from 9-bit to 12-bit (0.5°C to 0.0625°C resolution) using bit 6 and bit 5 of the CONFIG register. The user can gain better insight into the trends and characteristics of the ambient temperature by using a finer resolution. Increasing the resolution also reduces the quantization error. Figure 2-3 shows accuracy versus resolution.

Table 5-3 shows the T_A register conversion time for the corresponding resolution.

TABLE 5-3: RESOLUTION AND CONVERSION TIME

Bits	Resolution	t_{CONV} (typical)
9	0.5	30 ms
10	0.25	60 ms
11	0.125	120 ms
12	0.0625	240 ms

5.4 Summary of Power-up Condition

The MCP9800/1/2/3 has an internal Power-on Reset (POR) circuit. If the power supply voltage V_{DD} glitches down to the 1.7V (typical) threshold, the device resets the registers to the power-up default settings.

Table 5-4 shows the power-up default summary.

TABLE 5-4: POWER-UP DEFAULTS

Register	Data (Hex)	Power-up Defaults
T_A	0000	0°C
T_{SET}	A000	80°C
T_{HYST}	9600	75°C
Pointer	00	Temperature register
CONFIG	00	Continuous Conversion Comparator mode Active-low Output Fault Queue 1 9-bit Resolution

At power-up, the MCP9800/1/2/3 has an inherent 2 ms (typical) power-up delay before updating the registers with default values and start a conversion cycle. This delay reduces register corruption due to unsettled power. After power-up, it takes t_{CONV} for the TCN75A to update the T_A register with valid temperature data.

NOTES:

MCP9800/1/2/3

6.0 APPLICATIONS INFORMATION

6.1 Connecting to the Serial Bus

The SDA and SCL serial interface are open-drain pins that require pull-up resistors. This configuration is shown in Figure 6-1.

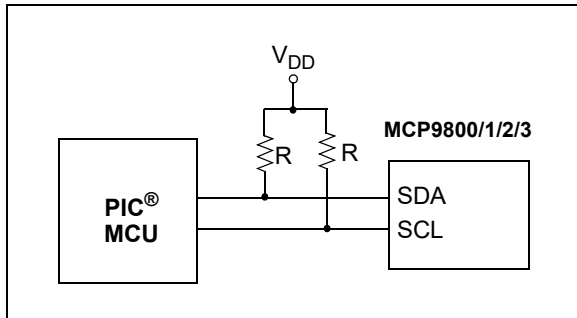

FIGURE 6-1: Pull-up Resistors on Serial Interface.

The MCP9800/1/2/3 is designed to meet 0.4V (maximum) voltage drop at 3 mA of current. This allows the MCP9800/1/2/3 to drive lower values of pull-up resistors and higher bus capacitance. In this application, all devices on the bus must meet the same pull-down current requirements.

6.2 Typical Application

Microchip provides several microcontroller product lines with host Synchronous Serial Port modules (HSSP) that include the I²C interface mode. This module implements all host and client functions and simplifies the firmware development overhead. Figure 6-2 shows a typical application using the PIC16F737 as a host to control other Microchip client products, such as EEPROM, fan speed controllers and the MCP9800 temperature sensor connected to the bus.

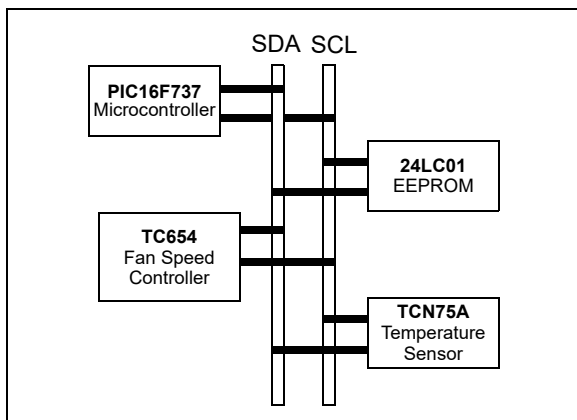

FIGURE 6-2: Multiple Devices on I²C™ Bus.

The ALERT output can be wired with a number of other open-drain devices. In such applications, the output needs to be programmed as an active-low output. Most systems will require pull-up resistors for this configuration.

6.3 Layout Considerations

The MCP9800/1/2/3 does not require any additional components besides the host controller in order to measure temperature. However, it is recommended that a decoupling capacitor of 0.1 μ F to 1 μ F be used between the V_{DD} and GND pins. A high-frequency ceramic capacitor is recommended. It is necessary for the capacitor to be located as close as possible to the power pins in order to provide effective noise protection.

For applications where a switching regulator is used to power the sensor, it is recommended to add a 200 Ω resistor in series to V_{DD} to filter out the switcher noise from the sensor. It is also recommended to add the series resistor in applications where a linear regulator is used to step-down a switching regulator voltage to power the sensor. For example, if a linearly regulated 3.3V from a 5V switching regulator is used to power the sensor, add a 200 Ω series resistor (refer to Figure 6-3).

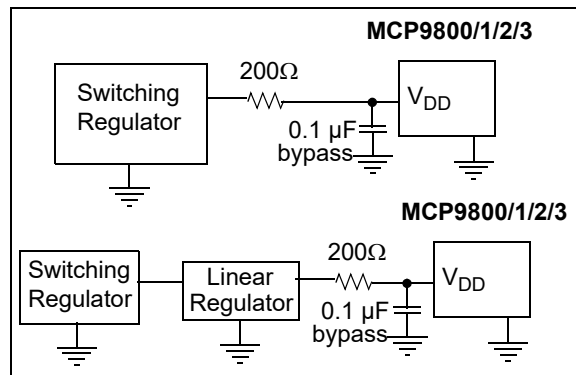

FIGURE 6-3: Power-supply Filter Using a Single Resistor.

6.4 Thermal Considerations

The MCP9800/1/2/3 measures temperature by monitoring the voltage of a diode located in the die. A low-impedance thermal path between the die and the Printed Circuit Board (PCB) is provided by the pins. Therefore, the MCP9800/1/2/3 effectively monitors the temperature of the PCB. However, the thermal path for the ambient air is not as efficient because the plastic device package functions as a thermal insulator.

A potential for self-heating errors can exist if the MCP9800/1/2/3 SDA and SCL communication lines are heavily loaded with pull-ups. Typically, the self-heating error is negligible because of the relatively small current consumption of the MCP9800/1/2/3. However, in order to maximize the temperature accuracy, the SDA and SCL pins need to be lightly loaded.

NOTES:

MCP9800/1/2/3

7.0 PACKAGING INFORMATION

7.1 Package Marking Information

5-Lead SOT-23

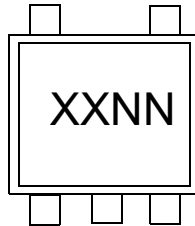

Example:

Part Number	MCP9800	Part Number	MCP9802
MCP9800A0T-M/OT	LDNN	MCP9802A0T-M/OT	JKNN
MCP9800A1T-M/OT	LENN	MCP9802A1T-M/OT	JLNN
MCP9800A2T-M/OT	LFNN	MCP9802A2T-M/OT	JMNN
MCP9800A3T-M/OT	LGNN	MCP9802A3T-M/OT	JPNN
MCP9800A4T-M/OT	LHNN	MCP9802A4T-M/OT	JQNN
MCP9800A5T-M/OT	LJNN	MCP9802A5T-M/OT	JRNN
MCP9800A6T-M/OT	LKNN	MCP9802A6T-M/OT	JSNN
MCP9800A7T-M/OT	LLNN	MCP9802A7T-M/OT	JTNN
MCP9800A5T-M/OTVAO	LJNN		

8-Lead MSOP

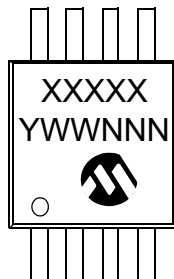

Example:

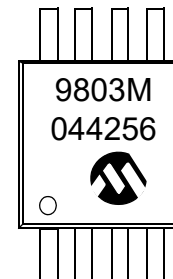

8-Lead SOIC (150 mil)

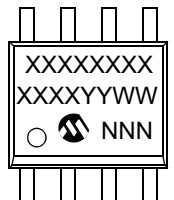

Example:

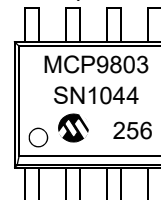

Legend:	XX...X	Customer-specific information
	Y	Year code (last digit of calendar year)
	YY	Year code (last 2 digits of calendar year)
	WW	Week code (week of January 1 is week '01')
	NNN	Alphanumeric traceability code
	(e3)	Pb-free JEDEC designator for Matte Tin (Sn)
	*	This package is Pb-free. The Pb-free JEDEC designator (e3) can be found on the outer packaging for this package.

Note: In the event the full Microchip part number cannot be marked on one line, it will be carried over to the next line, thus limiting the number of available characters for customer-specific information.

5-Lead Plastic Small Outline Transistor (OT) [SOT-23]

Note: For the most current package drawings, please see the Microchip Packaging Specification located at <http://www.microchip.com/packaging>

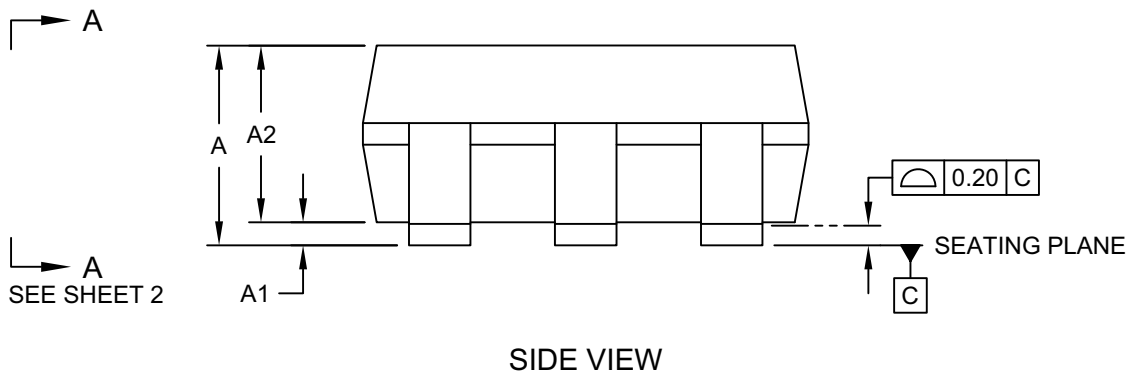
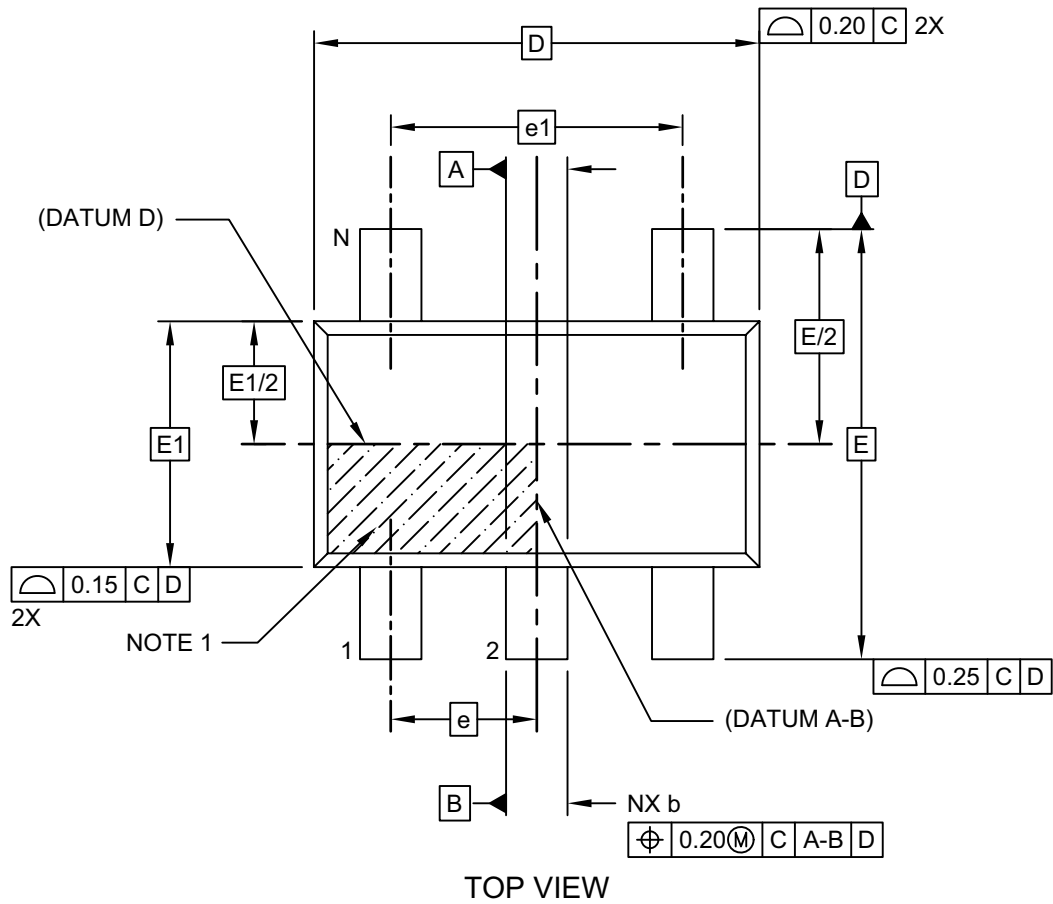

Microchip Technology Drawing C04-091-OT Rev H Sheet 1 of 2

MCP9800/1/2/3

5-Lead Plastic Small Outline Transistor (OT) [SOT-23]

Note: For the most current package drawings, please see the Microchip Packaging Specification located at <http://www.microchip.com/packaging>

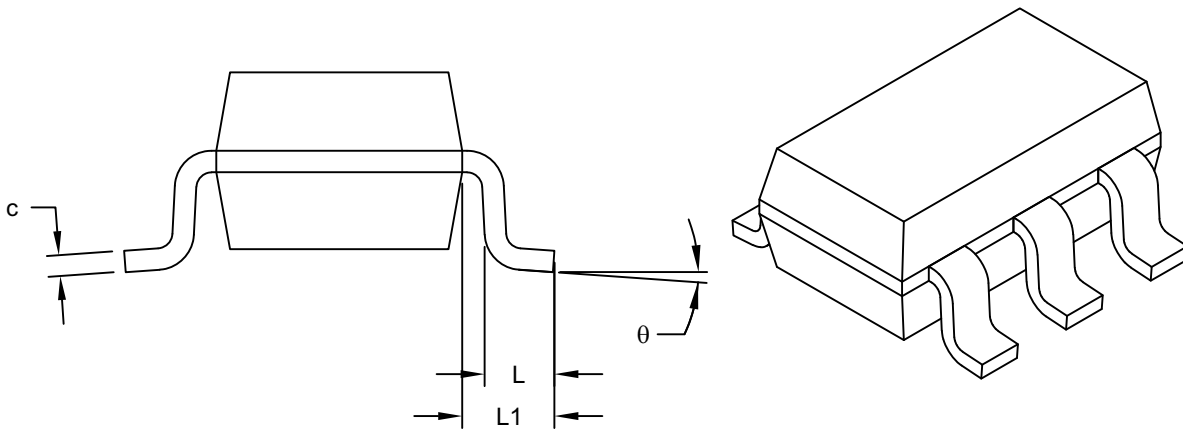

VIEW A-A
SHEET 1

Units		MILLIMETERS		
Dimension Limits		MIN	NOM	MAX
Number of Pins	N	5		
Pitch	e	0.95 BSC		
Outside lead pitch	e1	1.90 BSC		
Overall Height	A	0.90	-	1.45
Molded Package Thickness	A2	0.89	-	1.30
Standoff	A1	-	-	0.15
Overall Width	E	2.80 BSC		
Molded Package Width	E1	1.60 BSC		
Overall Length	D	2.90 BSC		
Foot Length	L	0.30	-	0.60
Footprint	L1	0.60 REF		
Foot Angle	θ	0°	-	10°
Lead Thickness	c	0.08	-	0.26
Lead Width	b	0.20	-	0.51

Notes:

- Dimensions D and E1 do not include mold flash or protrusions. Mold flash or protrusions shall not exceed 0.25mm per side.
- Dimensioning and tolerancing per ASME Y14.5M
BSC: Basic Dimension. Theoretically exact value shown without tolerances.
REF: Reference Dimension, usually without tolerance, for information purposes only.

Microchip Technology Drawing C04-091-OT Rev H Sheet 2 of 2

5-Lead Plastic Small Outline Transistor (OT) [SOT-23]

Note: For the most current package drawings, please see the Microchip Packaging Specification located at <http://www.microchip.com/packaging>

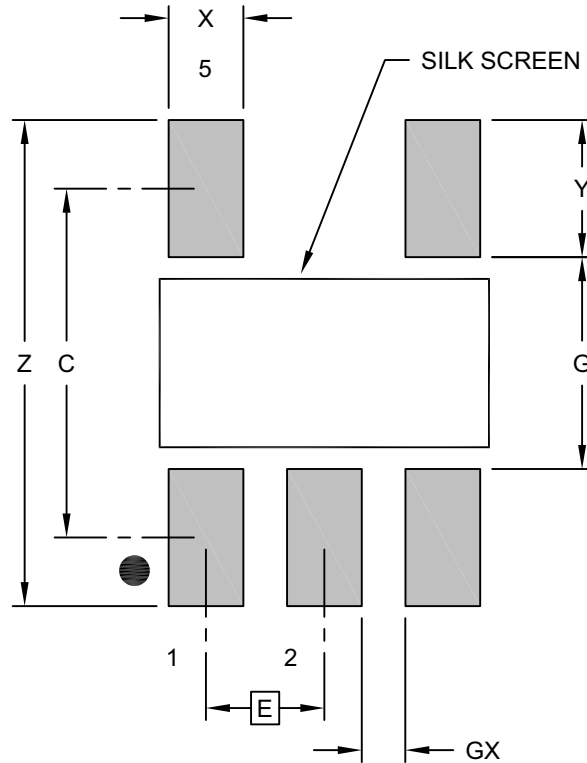

RECOMMENDED LAND PATTERN

Dimension Limits	Units	MILLIMETERS		
		MIN	NOM	MAX
Contact Pitch	E	0.95 BSC		
Contact Pad Spacing	C		2.80	
Contact Pad Width (X5)	X			0.60
Contact Pad Length (X5)	Y			1.10
Distance Between Pads	G	1.70		
Distance Between Pads	GX	0.35		
Overall Width	Z			3.90

Notes:

1. Dimensioning and tolerancing per ASME Y14.5M

BSC: Basic Dimension. Theoretically exact value shown without tolerances.

Microchip Technology Drawing No. C04-2091-OT Rev H

8-Lead Plastic Micro Small Outline Package (MS) - 3x3 mm Body [MSOP]

Note: For the most current package drawings, please see the Microchip Packaging Specification located at <http://www.microchip.com/packaging>

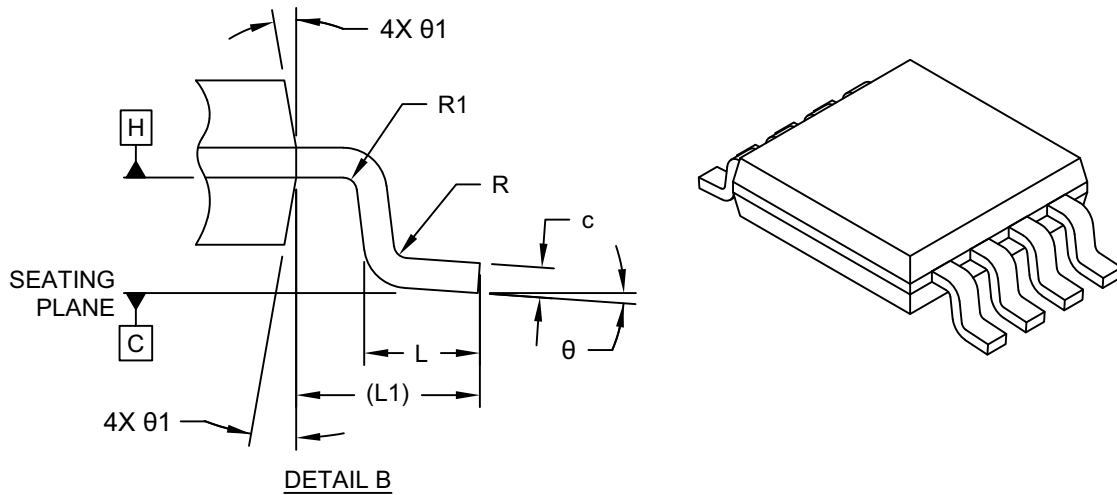

Dimension Limits	Units	MILLIMETERS		
		MIN	NOM	MAX
Number of Terminals	N	8		
Pitch	e	0.65 BSC		
Overall Height	A	–	–	1.10
Standoff	A1	0.00	–	0.15
Molded Package Thickness	A2	0.75	0.85	0.95
Overall Length	D	3.00 BSC		
Overall Width	E	4.90 BSC		
Molded Package Width	E1	3.00 BSC		
Terminal Width	b	0.22	–	0.40
Terminal Thickness	c	0.08	–	0.23
Terminal Length	L	0.40	0.60	0.80
Footprint	L1	0.95 REF		
Lead Bend Radius	R	0.07	–	–
Lead Bend Radius	R1	0.07	–	–
Foot Angle	θ	0°	–	8°
Mold Draft Angle	θ1	5°	–	15°

Notes:

- Pin 1 visual index feature may vary, but must be located within the hatched area.
- Dimensions D and E1 do not include mold flash or protrusions. Mold flash or protrusions shall not exceed 0.15mm per side.
- Dimensioning and tolerancing per ASME Y14.5M
 BSC: Basic Dimension. Theoretically exact value shown without tolerances.
 REF: Reference Dimension, usually without tolerance, for information purposes only.

MCP9800/1/2/3

8-Lead Plastic Micro Small Outline Package (MS) - 3x3 mm Body [MSOP]

Note: For the most current package drawings, please see the Microchip Packaging Specification located at <http://www.microchip.com/packageing>

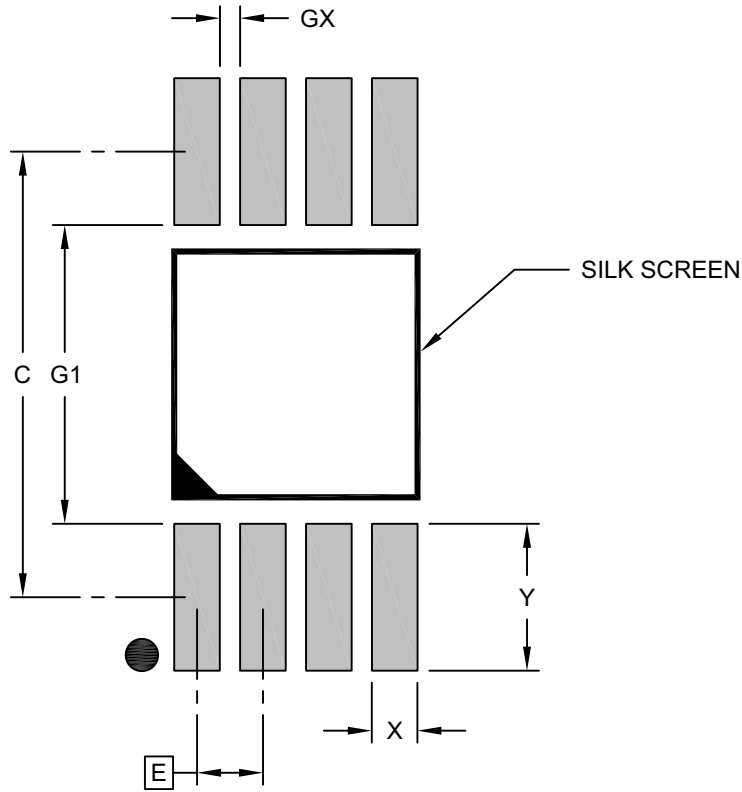

RECOMMENDED LAND PATTERN

Dimension Limits	Units	MILLIMETERS		
		MIN	NOM	MAX
Contact Pitch	E	0.65 BSC		
Contact Pad Spacing	C		4.40	
Contact Pad Width (X8)	X			0.45
Contact Pad Length (X8)	Y			1.45
Contact Pad to Contact Pad (X4)	G1	2.95		
Contact Pad to Contact Pad (X6)	GX	0.20		

Notes:

1. Dimensioning and tolerancing per ASME Y14.5M

BSC: Basic Dimension. Theoretically exact value shown without tolerances.

Microchip Technology Drawing C04-2111-MS Rev F

8-Lead Plastic Small Outline (SN) - Narrow, 3.90 mm (.150 In.) Body [SOIC]

Note: For the most current package drawings, please see the Microchip Packaging Specification located at <http://www.microchip.com/packaging>

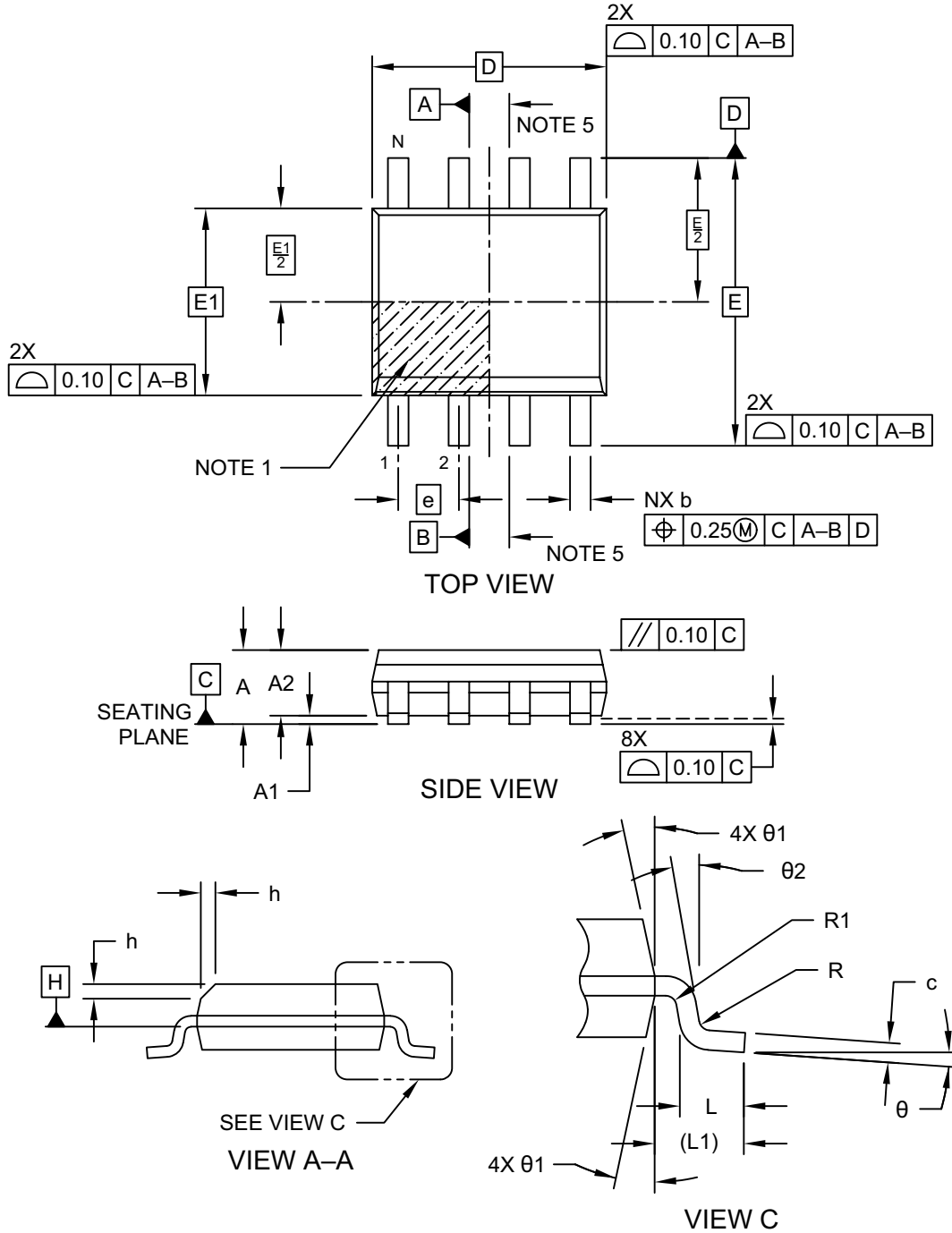

Microchip Technology Drawing No. C04-057-SN Rev K Sheet 1 of 2

MCP9800/1/2/3

8-Lead Plastic Small Outline (SN) - Narrow, 3.90 mm (.150 In.) Body [SOIC]

Note: For the most current package drawings, please see the Microchip Packaging Specification located at <http://www.microchip.com/packaging>

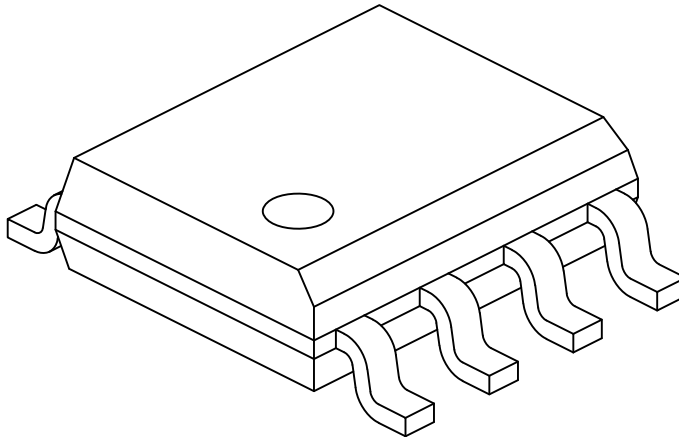

Dimension Limits	Units	MILLIMETERS		
		MIN	NOM	MAX
Number of Pins	N	8		
Pitch	e	1.27 BSC		
Overall Height	A	–	–	1.75
Molded Package Thickness	A2	1.25	–	–
Standoff §	A1	0.10	–	0.25
Overall Width	E	6.00 BSC		
Molded Package Width	E1	3.90 BSC		
Overall Length	D	4.90 BSC		
Chamfer (Optional)	h	0.25	–	0.50
Foot Length	L	0.40	–	1.27
Footprint	L1	1.04 REF		
Lead Thickness	c	0.17	–	0.25
Lead Width	b	0.31	–	0.51
Lead Bend Radius	R	0.07	–	–
Lead Bend Radius	R1	0.07	–	–
Foot Angle	θ	0°	–	8°
Mold Draft Angle	θ1	5°	–	15°
Lead Angle	θ2	0°	–	–

Notes:

1. Pin 1 visual index feature may vary, but must be located within the hatched area.
2. § Significant Characteristic
3. Dimensions D and E1 do not include mold flash or protrusions. Mold flash or protrusions shall not exceed 0.15mm per side.
4. Dimensioning and tolerancing per ASME Y14.5M
BSC: Basic Dimension. Theoretically exact value shown without tolerances.
REF: Reference Dimension, usually without tolerance, for information purposes only.
5. Datums A & B to be determined at Datum H.

Microchip Technology Drawing No. C04-057-SN Rev K Sheet 2 of 2

8-Lead Plastic Small Outline (SN) - Narrow, 3.90 mm (.150 In.) Body [SOIC]

Note: For the most current package drawings, please see the Microchip Packaging Specification located at <http://www.microchip.com/packaging>

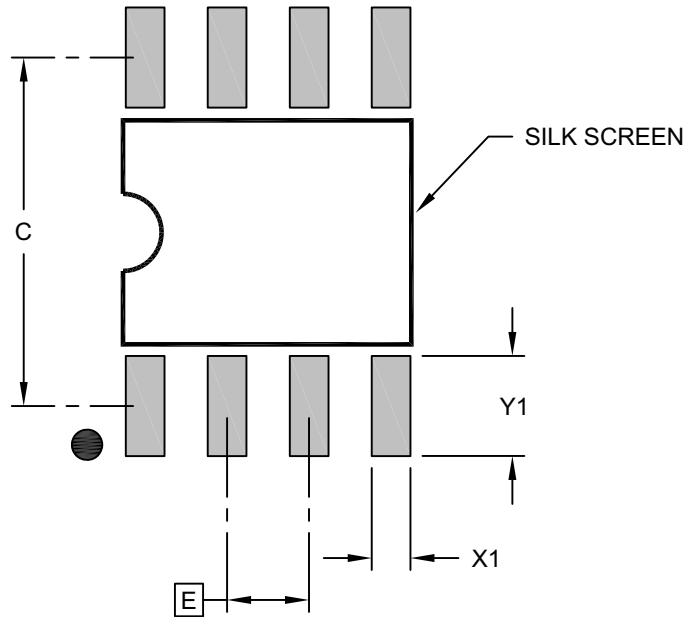

RECOMMENDED LAND PATTERN

Dimension Limits	Units	MILLIMETERS		
		MIN	NOM	MAX
Contact Pitch	E	1.27 BSC		
Contact Pad Spacing	C		5.40	
Contact Pad Width (X8)	X1			0.60
Contact Pad Length (X8)	Y1			1.55

Notes:

1. Dimensioning and tolerancing per ASME Y14.5M
BSC: Basic Dimension. Theoretically exact value shown without tolerances.

Microchip Technology Drawing C04-2057-SN Rev K

MCP9800/1/2/3

NOTES:

APPENDIX A: REVISION HISTORY

Revision E (July 2023)

The following is the list of modifications:

1. Added Automotive Qualification.
2. Updated the [Product Identification System](#) section.

Revision D (November 2010)

The following is the list of modifications:

1. Updated [Table 3-2](#) to include all available I²C address options for the MCP9800/02.
2. Added more package markings examples to the table in [Section 7.1, Package Marking Information](#).
3. Updated the [Product Identification System](#) section.

Revision C (September 2010)

The following is the list of modifications:

1. Updated [Section 6.3, Layout Considerations](#).
2. Updated package markings drawings.
3. Removed lead free designation letter G from [Section 7.0, Packaging Information](#) and from the [Product Identification System](#) page. All devices are lead free.
4. Added Appendix A: Revision History

Revision B (May 2008)

The following is the list of modifications:

1. Added lead free designation letter G in [Section 7.0, Packaging Information](#) and in the [Product Identification System](#) page.

Revision A (October 2004)

- Original Release of this Document.

MCP9800/1/2/3

NOTES:

PRODUCT IDENTIFICATION SYSTEM

To order or obtain information, e.g., on pricing or delivery, refer to the factory or the listed sales office.

PART NO.	XX	X	=X	/XX	
Device	Client Address	Tape & Reel	Temperature Range	Package	
<p>Device:</p> <p>MCP9800: Temperature Sensor MCP9801: Temperature Sensor MCP9802: Temperature Sensor MCP9803: Temperature Sensor</p> <p>A0 = Client address set to '000' A1 = Client address set to '001' A2 = Client address set to '010' A3 = Client address set to '011' A4 = Client address set to '100' A5 = Client address set to '101' A6 = Client address set to '110' A7 = Client address set to '111'</p> <p>Tape and Reel:</p> <p>= Blank T = Tape and Reel</p> <p>Temperature Range: M = -55°C to +125°C</p> <p>Package:</p> <p>OT = Plastic Small Outline Transistor (SOT-23), 5-lead MS = Plastic Micro Small Outline (MSOP), 8-lead SN = Plastic SOIC, (150 mil Body), 8-lead</p>					
<p>Examples:</p> <p>a) MCP9800A0T-M/OT Client address '000', Tape and Reel, -55°C to +125°C, SOT-23 package.</p> <p>b) MCP9800A5T-M/OT Client address '101', Tape and Reel, -55°C to +125°C, SOT-23 package.</p> <p>a) MCP9801-M/MS -55°C to +125°C, 8LD MSOP package.</p> <p>b) MCP9801T-M/MS Tape and Reel, -55°C to +125°C, 8LD MSOP package.</p> <p>c) MCP9801-M/SN -55°C to +125°C, 8LD SOIC package.</p> <p>d) MCP9801T-M/SN Tape and Reel, -55°C to +125°C, 8LD SOIC package.</p> <p>a) MCP9802A0T-M/OT Client address '000', Tape and Reel, -55°C to +125°C, SOT-23 package.</p> <p>b) MCP9802A5T-M/OT Client address '101', Tape and Reel, -55°C to +125°C, SOT-23 package.</p> <p>a) MCP9803-M/MS -55°C to +125°C, 8LD MSOP package.</p> <p>b) MCP9803T-M/MS Tape and Reel, -55°C to +125°C, 8LD MSOP package.</p> <p>c) MCP9803-M/SN -55°C to +125°C, 8LD SOIC package.</p> <p>d) MCP9803T-M/SN Tape and Reel, -55°C to +125°C, 8LD SOIC package.</p> <p>Note 1: Tape and Reel identifier only appears in the catalog part number description. This identifier is used for ordering purposes and is not printed on the device package. Check with your Microchip Sales Office for package availability with the Tape and Reel option.</p>					

MCP9800/1/2/3

PRODUCT IDENTIFICATION SYSTEM (AUTOMOTIVE)

To order or obtain information, e.g., on pricing or delivery, refer to the factory or the listed sales office.

<u>PART NO.</u>	<u>XX</u>	<u>X</u>	<u>=X</u>	<u>/XX</u>	<u>VAO</u>	Examples:
Device	Client Address	Tape & Reel	Temperature Range	Package	Automotive Qualified	a) MCP9800A5T-M/OTVAO Client address '101' Tape and Reel -55°C to +125°C SOT-23 package Automotive Qualified.
Device:	MCP9800: Temperature Sensor MCP9801: Temperature Sensor MCP9802: Temperature Sensor MCP9803: Temperature Sensor					
	A0 = Client address set to '000' A1 = Client address set to '001' A2 = Client address set to '010' A3 = Client address set to '011' A4 = Client address set to '100' A5 = Client address set to '101' A6 = Client address set to '110' A7 = Client address set to '111'					
Tape and Reel:	= Blank T = Tape and Reel					
Temperature Range:	M = -55°C to +125°C					
Package:	OT = Plastic Small Outline Transistor (SOT-23), 5-lead MS = Plastic Micro Small Outline (MSOP), 8-lead SN = Plastic SOIC, (150 mil Body), 8-lead					
Automotive Qualified:	VAO = Tested and qualified in accordance with AEC-Q100 requirements					
						<p>Note 1: Tape and Reel identifier only appears in the catalog part number description. This identifier is used for ordering purposes and is not printed on the device package. Check with your Microchip Sales Office for package availability with the Tape and Reel option.</p> <p>2: The VAO/XX automotive variants have been designed, manufactured, tested and qualified in accordance with AEC-Q100 requirements for automotive applications.</p>

Note the following details of the code protection feature on Microchip products:

- Microchip products meet the specifications contained in their particular Microchip Data Sheet.
- Microchip believes that its family of products is secure when used in the intended manner, within operating specifications, and under normal conditions.
- Microchip values and aggressively protects its intellectual property rights. Attempts to breach the code protection features of Microchip product is strictly prohibited and may violate the Digital Millennium Copyright Act.
- Neither Microchip nor any other semiconductor manufacturer can guarantee the security of its code. Code protection does not mean that we are guaranteeing the product is "unbreakable" Code protection is constantly evolving. Microchip is committed to continuously improving the code protection features of our products.

This publication and the information herein may be used only with Microchip products, including to design, test, and integrate Microchip products with your application. Use of this information in any other manner violates these terms. Information regarding device applications is provided only for your convenience and may be superseded by updates. It is your responsibility to ensure that your application meets with your specifications. Contact your local Microchip sales office for additional support or, obtain additional support at <https://www.microchip.com/en-us/support/design-help/client-support-services>.

THIS INFORMATION IS PROVIDED BY MICROCHIP "AS IS". MICROCHIP MAKES NO REPRESENTATIONS OR WARRANTIES OF ANY KIND WHETHER EXPRESS OR IMPLIED, WRITTEN OR ORAL, STATUTORY OR OTHERWISE, RELATED TO THE INFORMATION INCLUDING BUT NOT LIMITED TO ANY IMPLIED WARRANTIES OF NON-INFRINGEMENT, MERCHANTABILITY, AND FITNESS FOR A PARTICULAR PURPOSE, OR WARRANTIES RELATED TO ITS CONDITION, QUALITY, OR PERFORMANCE.

IN NO EVENT WILL MICROCHIP BE LIABLE FOR ANY INDIRECT, SPECIAL, PUNITIVE, INCIDENTAL, OR CONSEQUENTIAL LOSS, DAMAGE, COST, OR EXPENSE OF ANY KIND WHATSOEVER RELATED TO THE INFORMATION OR ITS USE, HOWEVER CAUSED, EVEN IF MICROCHIP HAS BEEN ADVISED OF THE POSSIBILITY OR THE DAMAGES ARE FORESEEABLE. TO THE FULLEST EXTENT ALLOWED BY LAW, MICROCHIP'S TOTAL LIABILITY ON ALL CLAIMS IN ANY WAY RELATED TO THE INFORMATION OR ITS USE WILL NOT EXCEED THE AMOUNT OF FEES, IF ANY, THAT YOU HAVE PAID DIRECTLY TO MICROCHIP FOR THE INFORMATION.

Use of Microchip devices in life support and/or safety applications is entirely at the buyer's risk, and the buyer agrees to defend, indemnify and hold harmless Microchip from any and all damages, claims, suits, or expenses resulting from such use. No licenses are conveyed, implicitly or otherwise, under any Microchip intellectual property rights unless otherwise stated.

For information regarding Microchip's Quality Management Systems, please visit www.microchip.com/quality.

Trademarks

The Microchip name and logo, the Microchip logo, Adaptec, AVR, AVR logo, AVR Freaks, BesTime, BitCloud, CryptoMemory, CryptoRF, dsPIC, flexPWR, HELDO, IGLoo, JukeBlox, KeeLoq, Klear, LANCheck, LinkMD, maXStylus, maXTouch, MediaLB, megaAVR, Microsemi, Microsemi logo, MOST, MOST logo, MPLAB, OptoLyzer, PIC, picoPower, PICSTART, PIC32 logo, PolarFire, Prochip Designer, QTouch, SAM-BA, SenGenuity, SpyNIC, SST, SST Logo, SuperFlash, Symmetricom, SyncServer, Tachyon, TimeSource, tinyAVR, UNI/O, Vectron, and XMEGA are registered trademarks of Microchip Technology Incorporated in the U.S.A. and other countries.

AgileSwitch, APT, ClockWorks, The Embedded Control Solutions Company, EtherSynch, Flashtec, Hyper Speed Control, HyperLight Load, Libero, motorBench, mTouch, Powermite 3, Precision Edge, ProASIC, ProASIC Plus, ProASIC Plus logo, Quiet-Wire, SmartFusion, SyncWorld, Temux, TimeCesium, TimeHub, TimePictra, TimeProvider, TrueTime, and ZL are registered trademarks of Microchip Technology Incorporated in the U.S.A.

Adjacent Key Suppression, AKS, Analog-for-the-Digital Age, Any Capacitor, AnyIn, AnyOut, Augmented Switching, BlueSky, BodyCom, Clockstudio, CodeGuard, CryptoAuthentication, CryptoAutomotive, CryptoCompanion, CryptoController, dsPICDEM, dsPICDEM.net, Dynamic Average Matching, DAM, ECAN, Espresso T1S, EtherGREEN, GridTime, IdealBridge, In-Circuit Serial Programming, ICSP, INICnet, Intelligent Paralleling, IntelliMOS, Inter-Chip Connectivity, JitterBlocker, Knob-on-Display, KoD, maxCrypto, maxView, memBrain, Mindi, MiWi, MPASM, MPF, MPLAB Certified logo, MPLIB, MPLINK, MultiTRAK, NetDetach, Omniscient Code Generation, PICDEM, PICDEM.net, PICkit, PICtail, PowerSmart, PureSilicon, QMatrix, REAL ICE, Ripple Blocker, RTAX, RTG4, SAM-ICE, Serial Quad I/O, simpleMAP, SimpliPHY, SmartBuffer, SmartHLS, SMART-I.S., storClad, SQI, SuperSwitcher, SuperSwitcher II, Switchtec, SynchroPHY, Total Endurance, Trusted Time, TSHARC, USBCheck, VariSense, VectorBlox, VeriPHY, ViewSpan, WiperLock, XpressConnect, and ZENA are trademarks of Microchip Technology Incorporated in the U.S.A. and other countries.

SQTP is a service mark of Microchip Technology Incorporated in the U.S.A.

The Adaptec logo, Frequency on Demand, Silicon Storage Technology, and Symmcom are registered trademarks of Microchip Technology Inc. in other countries.

GestIC is a registered trademark of Microchip Technology Germany II GmbH & Co. KG, a subsidiary of Microchip Technology Inc., in other countries.

All other trademarks mentioned herein are property of their respective companies.

© 2004-2023, Microchip Technology Incorporated and its subsidiaries.

All Rights Reserved.

ISBN: 978-1-6683-2880-4



MICROCHIP

Worldwide Sales and Service

AMERICAS

Corporate Office
2355 West Chandler Blvd.
Chandler, AZ 85224-6199
Tel: 480-792-7200
Fax: 480-792-7277
Technical Support:
<http://www.microchip.com/support>
Web Address:
www.microchip.com

Atlanta
Duluth, GA
Tel: 678-957-9614
Fax: 678-957-1455

Austin, TX
Tel: 512-257-3370

Boston
Westborough, MA
Tel: 774-760-0087
Fax: 774-760-0088

Chicago
Itasca, IL
Tel: 630-285-0071
Fax: 630-285-0075

Dallas
Addison, TX
Tel: 972-818-7423
Fax: 972-818-2924

Detroit
Novi, MI
Tel: 248-848-4000

Houston, TX
Tel: 281-894-5983

Indianapolis
Noblesville, IN
Tel: 317-773-8323
Fax: 317-773-5453
Tel: 317-536-2380

Los Angeles
Mission Viejo, CA
Tel: 949-462-9523
Fax: 949-462-9608
Tel: 951-273-7800

Raleigh, NC
Tel: 919-844-7510

New York, NY
Tel: 631-435-6000

San Jose, CA
Tel: 408-735-9110
Tel: 408-436-4270

Canada - Toronto
Tel: 905-695-1980
Fax: 905-695-2078

ASIA/PACIFIC

Australia - Sydney
Tel: 61-2-9868-6733

China - Beijing
Tel: 86-10-8569-7000

China - Chengdu
Tel: 86-28-8665-5511

China - Chongqing
Tel: 86-23-8980-9588

China - Dongguan
Tel: 86-769-8702-9880

China - Guangzhou
Tel: 86-20-8755-8029

China - Hangzhou
Tel: 86-571-8792-8115

China - Hong Kong SAR
Tel: 852-2943-5100

China - Nanjing
Tel: 86-25-8473-2460

China - Qingdao
Tel: 86-532-8502-7355

China - Shanghai
Tel: 86-21-3326-8000

China - Shenyang
Tel: 86-24-2334-2829

China - Shenzhen
Tel: 86-755-8864-2200

China - Suzhou
Tel: 86-186-6233-1526

China - Wuhan
Tel: 86-27-5980-5300

China - Xian
Tel: 86-29-8833-7252

China - Xiamen
Tel: 86-592-2388138

China - Zhuhai
Tel: 86-756-3210040

ASIA/PACIFIC

India - Bangalore
Tel: 91-80-3090-4444

India - New Delhi
Tel: 91-11-4160-8631

India - Pune
Tel: 91-20-4121-0141

Japan - Osaka
Tel: 81-6-6152-7160

Japan - Tokyo
Tel: 81-3-6880-3770

Korea - Daegu
Tel: 82-53-744-4301

Korea - Seoul
Tel: 82-2-554-7200

Malaysia - Kuala Lumpur
Tel: 60-3-7651-7906

Malaysia - Penang
Tel: 60-4-227-8870

Philippines - Manila
Tel: 63-2-634-9065

Singapore
Tel: 65-6334-8870

Taiwan - Hsin Chu
Tel: 886-3-577-8366

Taiwan - Kaohsiung
Tel: 886-7-213-7830

Taiwan - Taipei
Tel: 886-2-2508-8600

Thailand - Bangkok
Tel: 66-2-694-1351

Vietnam - Ho Chi Minh
Tel: 84-28-5448-2100

EUROPE

Austria - Wels
Tel: 43-7242-2244-39
Fax: 43-7242-2244-393

Denmark - Copenhagen
Tel: 45-4485-5910
Fax: 45-4485-2829

Finland - Espoo
Tel: 358-9-4520-820

France - Paris
Tel: 33-1-69-53-63-20
Fax: 33-1-69-30-90-79

Germany - Garching
Tel: 49-8931-9700

Germany - Haan
Tel: 49-2129-3766400

Germany - Heilbronn
Tel: 49-7131-72400

Germany - Karlsruhe
Tel: 49-721-625370

Germany - Munich
Tel: 49-89-627-144-0
Fax: 49-89-627-144-44

Germany - Rosenheim
Tel: 49-8031-354-560

Israel - Ra'anana
Tel: 972-9-744-7705

Italy - Milan
Tel: 39-0331-742611
Fax: 39-0331-466781

Italy - Padova
Tel: 39-049-7625286

Netherlands - Drunen
Tel: 31-416-690399
Fax: 31-416-690340

Norway - Trondheim
Tel: 47-7288-4388

Poland - Warsaw
Tel: 48-22-3325737

Romania - Bucharest
Tel: 40-21-407-87-50

Spain - Madrid
Tel: 34-91-708-08-90
Fax: 34-91-708-08-91

Sweden - Gothenberg
Tel: 46-31-704-60-40

Sweden - Stockholm
Tel: 46-8-5090-4654

UK - Wokingham
Tel: 44-118-921-5800
Fax: 44-118-921-5820