

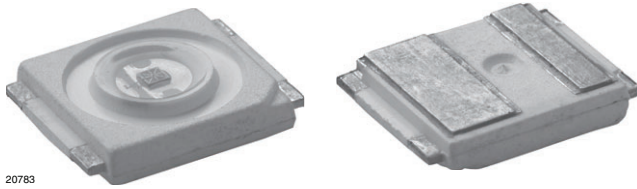

High Power Infrared Emitting Diode, 850 nm, Surface Emitter Technology



20783

DESCRIPTION

As part of the [SurfLight™](#) portfolio, the VSMY7852X01 is an infrared, 850 nm emitting diode based on surface emitter technology with high radiant power and high speed, molded in low thermal resistance Little Star package. A 20 mil chip provides outstanding low forward voltage and allows DC operation of the device up to 250 mA.

APPLICATIONS

- Infrared illumination for CMOS cameras (CCTV)
- Machine vision IR data transmission

FEATURES

- Package type: surface-mount
- Package form: Little Star®
- Dimensions (L x W x H in mm): 6.0 x 7.0 x 1.5
- Peak wavelength: $\lambda_p = 850$ nm
- High reliability
- High radiant power
- High radiant intensity
- Angle of half intensity: $\phi = \pm 60^\circ$
- Low forward voltage
- Designed for high drive currents: up to 250 mA DC and up to 1.5 A pulses
- Low thermal resistance: $R_{thJP} = 15$ K/W
- Floor life: 1 year, MSL 2, according to J-STD-020
- Lead (Pb)-free reflow soldering
- Material categorization: for definitions of compliance please see www.vishay.com/doc?99912



RoHS COMPLIANT

PRODUCT SUMMARY				
COMPONENT	I_e (mW/sr)	ϕ (deg)	λ_p (nm)	t_r (ns)
VSMY7852X01	55	± 60	850	8

Note

- Test conditions see table "Basic Characteristics"

ORDERING INFORMATION			
ORDERING CODE	PACKAGING	REMARKS	PACKAGE FORM
VSMY7852X01-GS08	Tape and reel	MOQ: 2000 pcs, 2000 pcs/reel	Little Star

Note

- MOQ: minimum order quantity

ABSOLUTE MAXIMUM RATINGS ($T_{amb} = 25$ °C, unless otherwise specified)				
PARAMETER	TEST CONDITION	SYMBOL	VALUE	UNIT
Reverse voltage		V_R	5	V
Forward current		I_F	250	mA
Peak forward current	$t_p/T = 0.5, t_p = 100$ μ s	I_{FM}	500	mA
Surge forward current	$t_p = 100$ μ s	I_{FSM}	1.5	A
Power dissipation		P_V	500	mW
Junction temperature		T_j	125	°C
Operating temperature range		T_{amb}	-40 to +100	°C
Storage temperature range		T_{stg}	-40 to +100	°C
Soldering temperature	According to Fig. 7, J-STD-20	T_{sd}	260	°C
Thermal resistance junction-to-pin	According to J-STD-051, soldered on PCB	R_{thJP}	15	K/W

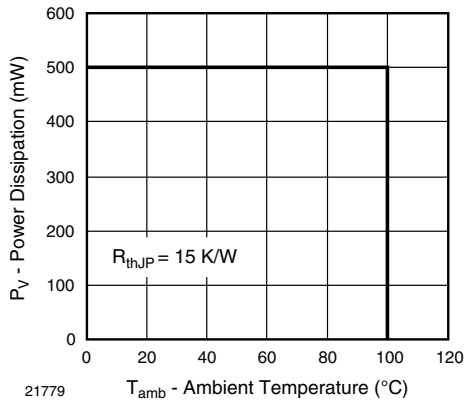

Fig. 1 - Power Dissipation Limit vs. Ambient Temperature

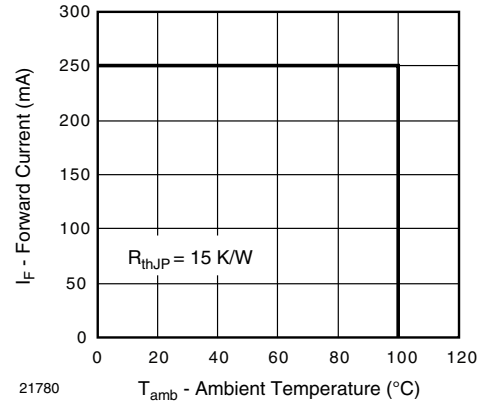

Fig. 2 - Forward Current Limit vs. Ambient Temperature

BASIC CHARACTERISTICS ($T_{amb} = 25\text{ }^{\circ}\text{C}$, unless otherwise specified)						
PARAMETER	TEST CONDITION	SYMBOL	MIN.	TYP.	MAX.	UNIT
Forward voltage	$I_F = 250\text{ mA}$, $t_p = 10\text{ ms}$	V_F	-	1.7	2.0	V
Temperature coefficient of V_F	$I_F = 1\text{ mA}$	TK_{V_F}	-	-1.5	-	mV/K
Reverse current	$V_R = 5\text{ V}$	I_R	Not designed for reverse operation			μA
Radiant intensity	$I_F = 250\text{ mA}$, $t_p = 10\text{ ms}$	I_e	30	55	90	mW/sr
Radiant power	$I_F = 250\text{ mA}$, $t_p = 20\text{ ms}$	ϕ_e	-	130	-	mW
Temperature coefficient of ϕ_e	$I_F = 1\text{ A}$	TK_{ϕ_e}	-	-0.5	-	%/K
Angle of half intensity		ϕ	-	± 60	-	deg
Peak wavelength	$I_F = 250\text{ mA}$	λ_p	-	850	-	nm
Spectral bandwidth	$I_F = 250\text{ mA}$	$\Delta\lambda$	-	30	-	nm
Temperature coefficient of λ_p	$I_F = 250\text{ mA}$	TK_{λ_p}	-	0.2	-	nm/K
Rise time	$I_F = 250\text{ mA}$	t_r	-	8	-	ns
Fall time	$I_F = 250\text{ mA}$	t_f	-	10	-	ns

BASIC CHARACTERISTICS ($T_{amb} = 25\text{ }^{\circ}\text{C}$, unless otherwise specified)

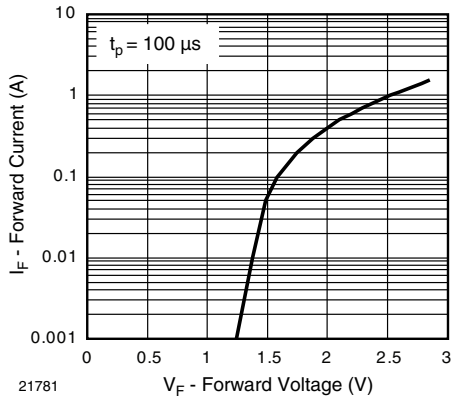

Fig. 3 - Forward Current vs. Forward Voltage

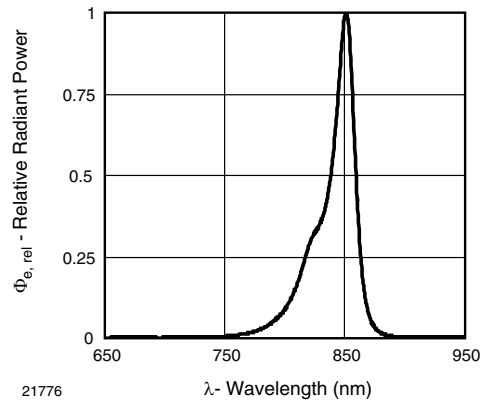

Fig. 5 - Relative Radiant Power vs. Wavelength

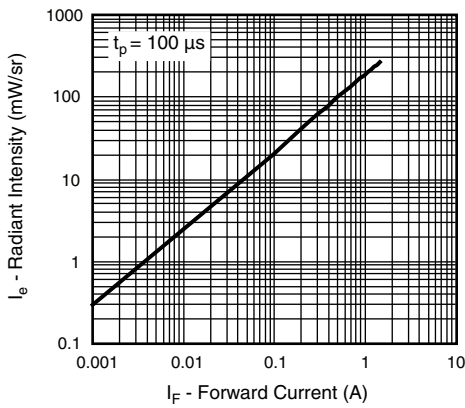

Fig. 4 - Radiant Intensity vs. Forward Current

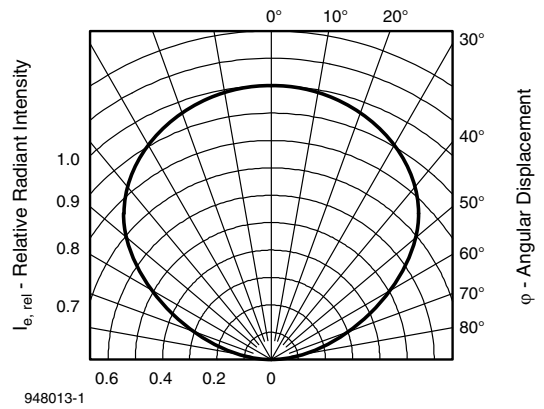
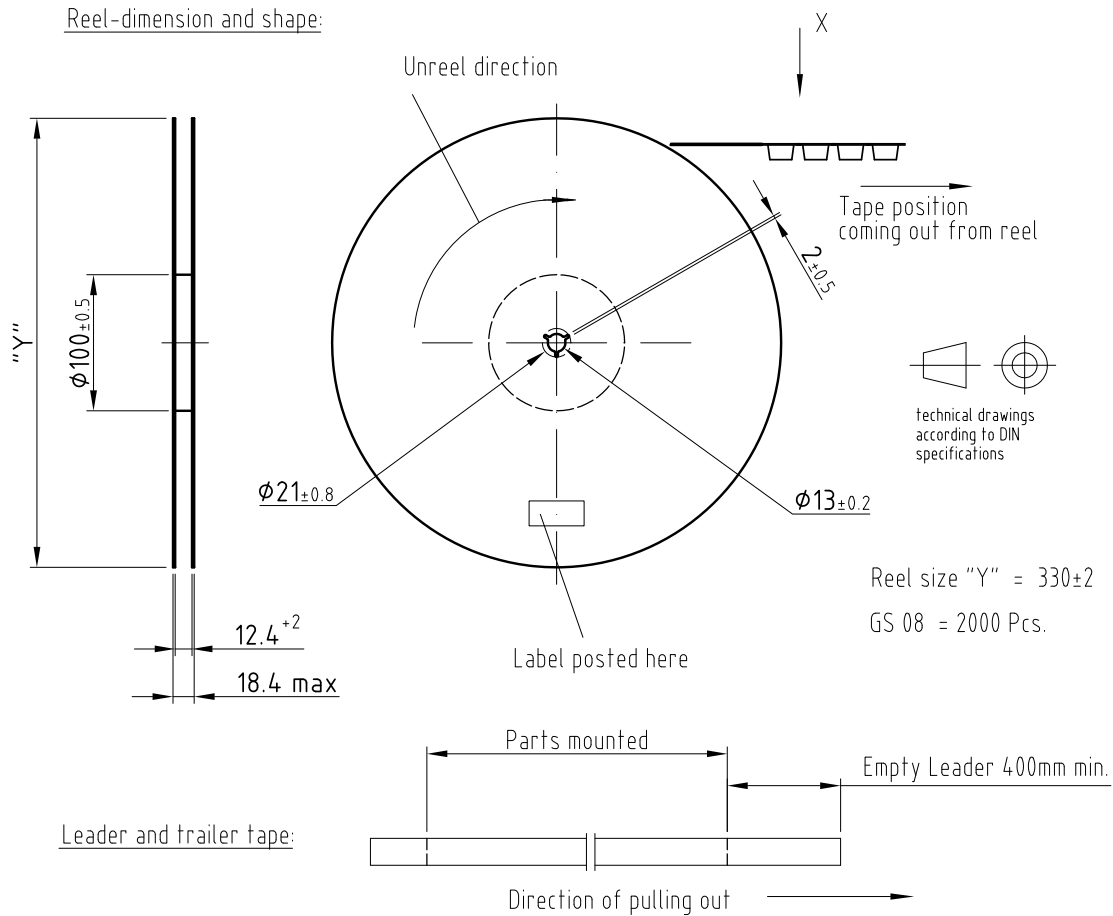
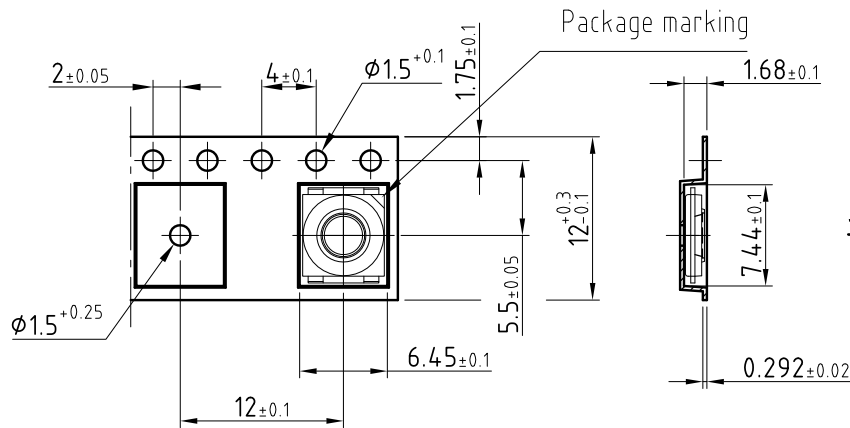

Fig. 6 - Relative Radiant Intensity vs. Angular Displacement

TAPING DIMENSIONS in millimeters



Leader and trailer tape:



Drawing-No: 9.800-5094.01-4

Issue: 3; 22.01.08

20846



PACKAGE DIMENSIONS in millimeters

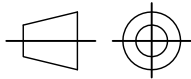
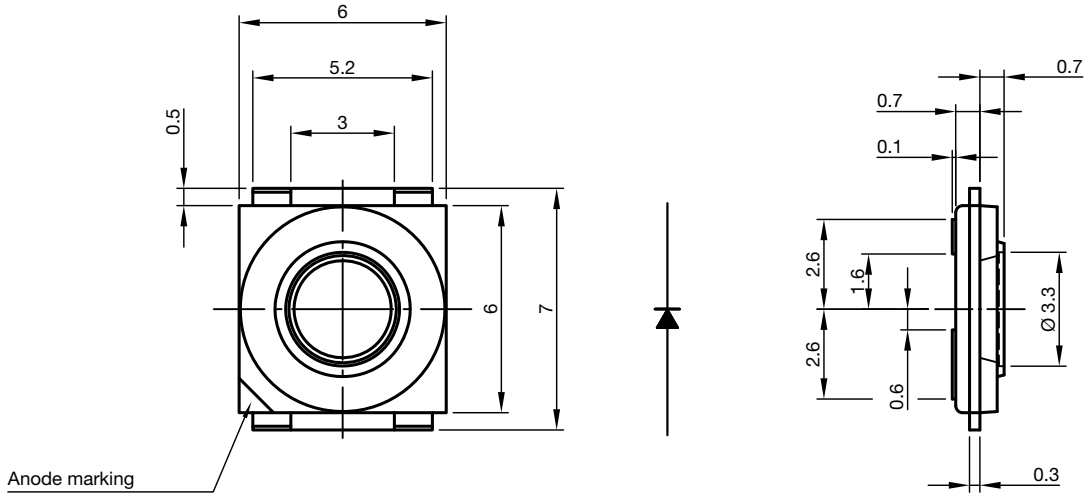

technical drawings according to DIN specifications

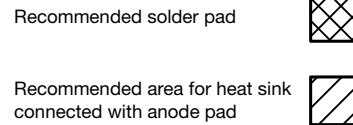

Not indicated tolerances ± 0.1

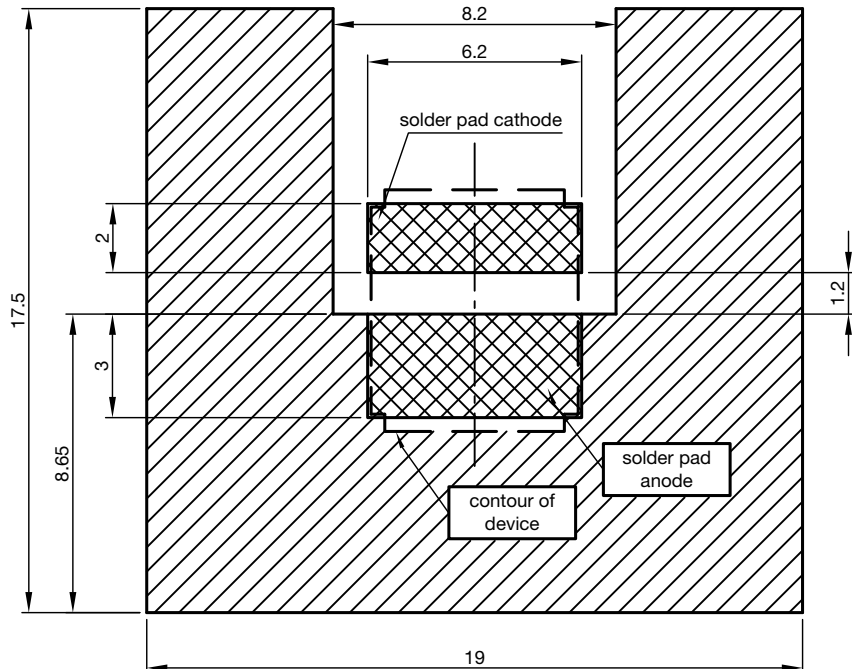

Drawing-No.: 6.541-5076.01-4
Issue: 3; 22.10.14

SOLDER PROFILE

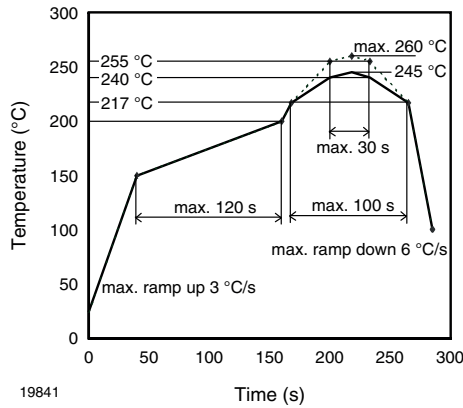

Fig. 7 - Lead (Pb)-free Reflow Solder Profile According to J-STD-020 for Preconditioning According to JEDEC®, Level 2

DRYPACK

Devices are packed in moisture barrier bags (MBB) to prevent the products from moisture absorption during transportation and storage. Each bag contains a desiccant.

FLOOR LIFE

Floor life (time between soldering and removing from MBB) must not exceed the time indicated on MBB label:

Floor life: 1 year

Conditions: $T_{amb} < 30\text{ }^{\circ}\text{C}$, $RH < 60\%$

Moisture sensitivity level 2, according to J-STD-020B

DRYING

In case of moisture absorption devices should be baked before soldering. Conditions see J-STD-020 or label. Devices taped on reel dry using recommended conditions 192 h at $40\text{ }^{\circ}\text{C}$ ($+ 5\text{ }^{\circ}\text{C}$), $RH < 5\%$.



Disclaimer

ALL PRODUCT, PRODUCT SPECIFICATIONS AND DATA ARE SUBJECT TO CHANGE WITHOUT NOTICE TO IMPROVE RELIABILITY, FUNCTION OR DESIGN OR OTHERWISE.

Vishay Intertechnology, Inc., its affiliates, agents, and employees, and all persons acting on its or their behalf (collectively, "Vishay"), disclaim any and all liability for any errors, inaccuracies or incompleteness contained in any datasheet or in any other disclosure relating to any product.

Vishay makes no warranty, representation or guarantee regarding the suitability of the products for any particular purpose or the continuing production of any product. To the maximum extent permitted by applicable law, Vishay disclaims (i) any and all liability arising out of the application or use of any product, (ii) any and all liability, including without limitation special, consequential or incidental damages, and (iii) any and all implied warranties, including warranties of fitness for particular purpose, non-infringement and merchantability.

Statements regarding the suitability of products for certain types of applications are based on Vishay's knowledge of typical requirements that are often placed on Vishay products in generic applications. Such statements are not binding statements about the suitability of products for a particular application. It is the customer's responsibility to validate that a particular product with the properties described in the product specification is suitable for use in a particular application. Parameters provided in datasheets and / or specifications may vary in different applications and performance may vary over time. All operating parameters, including typical parameters, must be validated for each customer application by the customer's technical experts. Product specifications do not expand or otherwise modify Vishay's terms and conditions of purchase, including but not limited to the warranty expressed therein.

Except as expressly indicated in writing, Vishay products are not designed for use in medical, life-saving, or life-sustaining applications or for any other application in which the failure of the Vishay product could result in personal injury or death. Customers using or selling Vishay products not expressly indicated for use in such applications do so at their own risk. Please contact authorized Vishay personnel to obtain written terms and conditions regarding products designed for such applications.

No license, express or implied, by estoppel or otherwise, to any intellectual property rights is granted by this document or by any conduct of Vishay. Product names and markings noted herein may be trademarks of their respective owners.

Mouser Electronics

Authorized Distributor

Click to View Pricing, Inventory, Delivery & Lifecycle Information:

[Vishay:](#)

[VSMY7852X01-GS08](#)