

XT112S1PCM12

capacitive sensor - XT1 - cylindrical M12 -
stainless steel - Sn 2mm - 24 V DC

Product availability: Non-Stock - Not normally stocked in distribution facility

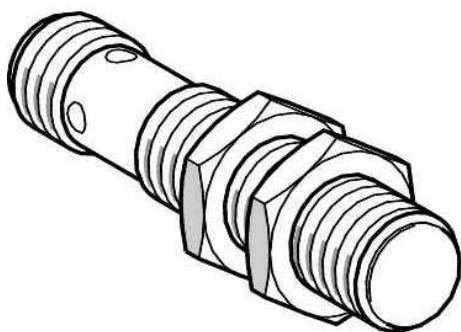

Main

Commercial Status	Commercialised
Range of product	OsiSense XT
Sensor type	Capacitive proximity sensor
Product specific application	Detection of insulated or conductive materials
Sensor name	XT1
Sensor design	Cylindrical M12
Size	51 mm
Body type	Fixed
Detector flush mounting acceptance	Flush mountable
Material	Stainless steel
Enclosure material	Stainless steel 303
Type of output signal	Discrete
Wiring technique	4-wire
[Sn] nominal sensing distance	0.08 in (2 mm)
Discrete output function	1 NC + 1 NO
Output circuit type	DC
Discrete output type	PNP
Electrical connection	4 pins M12 male connector
[Us] rated supply voltage	24 V DC with reverse polarity protection
Delay response	<= 5 ms
IP degree of protection	IP65 conforming to IEC 60947-5-2 IP65 conforming to IEC 60529

Complementary

ISO thread	M12 x 1
Detection face	Frontal
[Sa] assured operating distance	0...0.06 in (0...1.44 mm)
Adjustment zone	0.02...0.2 in (0.5...5 mm)
Differential travel	< 0.2 x Sr
Repeat accuracy	< 0.1 x Sr
Status LED	1 LED (yellow) for output state indication
Supply voltage limits	12...30 V DC
Residual current	< 0.1 mA (open state)
Protection type	Short-circuit protection
Switching frequency	<= 300 Hz
Voltage drop	<= 2 V (closed)
Current consumption	< 15 mA
Delay first up	<= 30 ms
Delay recovery	<= 5 ms
Maximum switching current	200 mA
Marking	CE
Setting-up	Sensitivity by potentiometer
Threaded length	1.57 in (40 mm)
Product weight	0.09 lb(US) (0.04 kg)

Environment

Standards	EN/IEC 60947-5-2
Product certifications	CETLus
Ambient air temperature for operation	-13...158 °F (-25...70 °C)
Vibration resistance	10 gn amplitude = 1 mm (10...55 Hz) conforming to IEC 60068-2-6
Shock resistance	30 gn (duration = 11 ms) conforming to IEC 60068-2-27
Resistance to electrostatic discharge	8 kV (air) conforming to IEC 61000-4-2 4 kV (contact) conforming to IEC 61000-4-2
Resistance to electromagnetic fields	2.74 V/yd (3 V/m) conforming to IEC 61000-4-3
Resistance to fast transients	2 kV conforming to IEC 61000-4-4

Ordering and shipping details

Category	22490 - SENSORS-ULTRASONIC (XX5,6)
Discount Schedule	DS2
GTIN	003389119025829
Nbr. of units in pkg.	1
Package weight(Lbs)	0.30
Product availability	Non-Stock - Not normally stocked in distribution facility
Returnability	N
Country of origin	DE

Offer Sustainability

Sustainable offer status	Not Green Premium product
RoHS	Compliant - since 0727 - Schneider Electric declaration of conformity

Contractual warranty

Period	18 months
--------	-----------

Mouser Electronics

Authorized Distributor

Click to View Pricing, Inventory, Delivery & Lifecycle Information:

[Schneider Electric:](#)

[XT112S1PCM12](#)