

NOTES:

1. ROHS COMPLIANT
2. PLASTIC HOUSING: THERMOPLASTIC MATERIAL WITH FLAMMABILITY RATING UL 94V-0 OR BETTER.
3. CONTACTS PLATING: 50 MICROINCHES GOLD PLATING.
4. CONTACTS BASE MATERIAL: PHOSPHOR BRONZE
5. UNDER PLATING: 30-50u INCHES NICKEL
6. SOLDER TAIL PLATING : 200-500 uINCHES 100% TIN, MATTE FINISH.
7. METAL SHIELD: NICKEL PLATING ON COPPER ALLOY.
8. JACK CAVITY CONFORMS TO FCC PART 68 SUBPART.
9. PCB PLATING: HASL
10. STORAGE TEMPERATURE: -20°C TO +125°C
11. COMPLIANCE TO J-STD:
  - A. J-STD-002: SOLDERABILITY AT 245°C DIP AND LOOK TEST
  - B. J-STD-020: LEVEL 1, NO MOISTURE SENSITIVE
  - C. J-STD-075: W2, 270°C MAXIMUM THROUGH WAVE SOLDER

LED GREEN/YELLOW  
(8 PLACES)

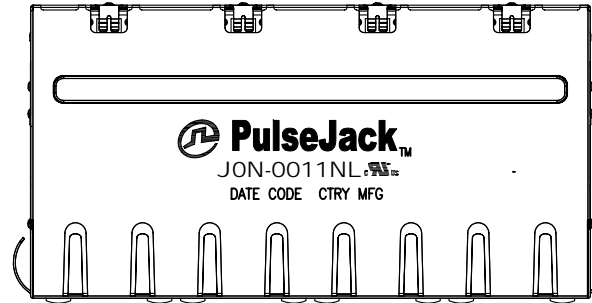

PIN 1

PIN 8

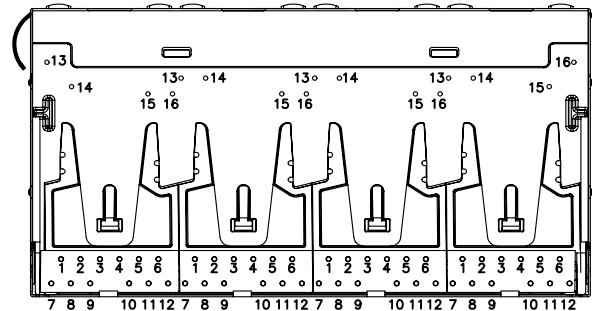
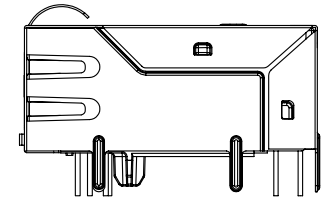
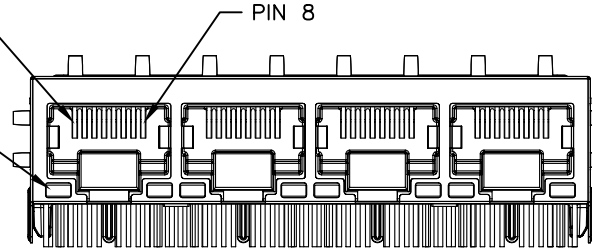

FINAL OUTLINE

© Copyright, 2014. Pulse Electronics Corp. All rights reserved. Pulse confidential & proprietary. (11/12/14)

PRODUCT DESCRIPTION	TLA DRAWING	PS DRAWING	SHEET	PART NO.	DATASHEET REV.
CONN,RJ45,1X4,10/100/1000,1:1,TD	JON-0011NL-11	PS-2476.008-A	1 OF 5	JON-0011NL	A

ELECTRICAL CHARACTERISTICS AT +25°C UNLESS OTHER SPECIFIED  
MEETS IEEE 802.3 SPECIFICATION

PARAMETER	SPECIFICATIONS	
OPERATING TEMPERATURE	0°C–70°C	
TURNS RATIO	1.00 ± 2%	
POLARITY	PER SCHEMATIC	
INSERTION LOSS	100 KHz	1–125 MHz
	-1.2 dB MAX	-0.2–0.002*f <sup>1.4</sup> dB MAX
RETURN LOSS (Z OUT = 100 OHM ±15%)	.1–40 MHz	40–100 MHz
	-16 dB MIN	-10+20*LOG <sub>10</sub> (f/80 MHz) dB MIN
INDUCTANCE (OCL) (MEDIA SIDE, 0°C–70°C)	350 uH MIN (MEASURED AT 100 KHz, 100 mVRMS AND WITH 8 mA DC BIAS)	
CROSSTALK, ADJACENT CHANNELS	1 MHz	10–100 MHz
	-50 dB MIN	-55+22*LOG <sub>10</sub> (f/10) dB MIN
COMMON MODE REJECTION RATIO	2 MHz	30–200 MHz
	-50 dB MIN	-15+20*LOG <sub>10</sub> (f/200) dB MIN
DC RESISTANCE, 1/2 WINDING	.65 OHMS MAX	
DC RESISTANCE IMBALANCE	±.065 OHMS MAX (CENTER TAP SYMMETRY)	
DC CURRENT RATING	350 mA MAX	
INPUT – OUTPUT ISOLATION	2250 VDC FOR 60 SECONDS	

NOTE: f IS FREQUENCY IN MHz.

EMMITTED COLOR	GREEN	YELLOW
WAVELENGTH (nm)	570 nm	586 nm
BRIGHTNESS (mCD)	4 TYP. @ 20mA	10 TYP. @ 20 mA
VIEWING ANGLE	150°	150°
POWER DISSIPATION (Pd)	85 mW MAX	85 mW MAX
PEAK FORWARD CURRENT (10us PULSE)	120 MA MAX	80 MA MAX
FORWARD VOLTAGE (Vf)	2.2 TO 2.8 V	2.1 TO 2.8 V

NOTE: PER VENDOR'S SPECIFICATIONS

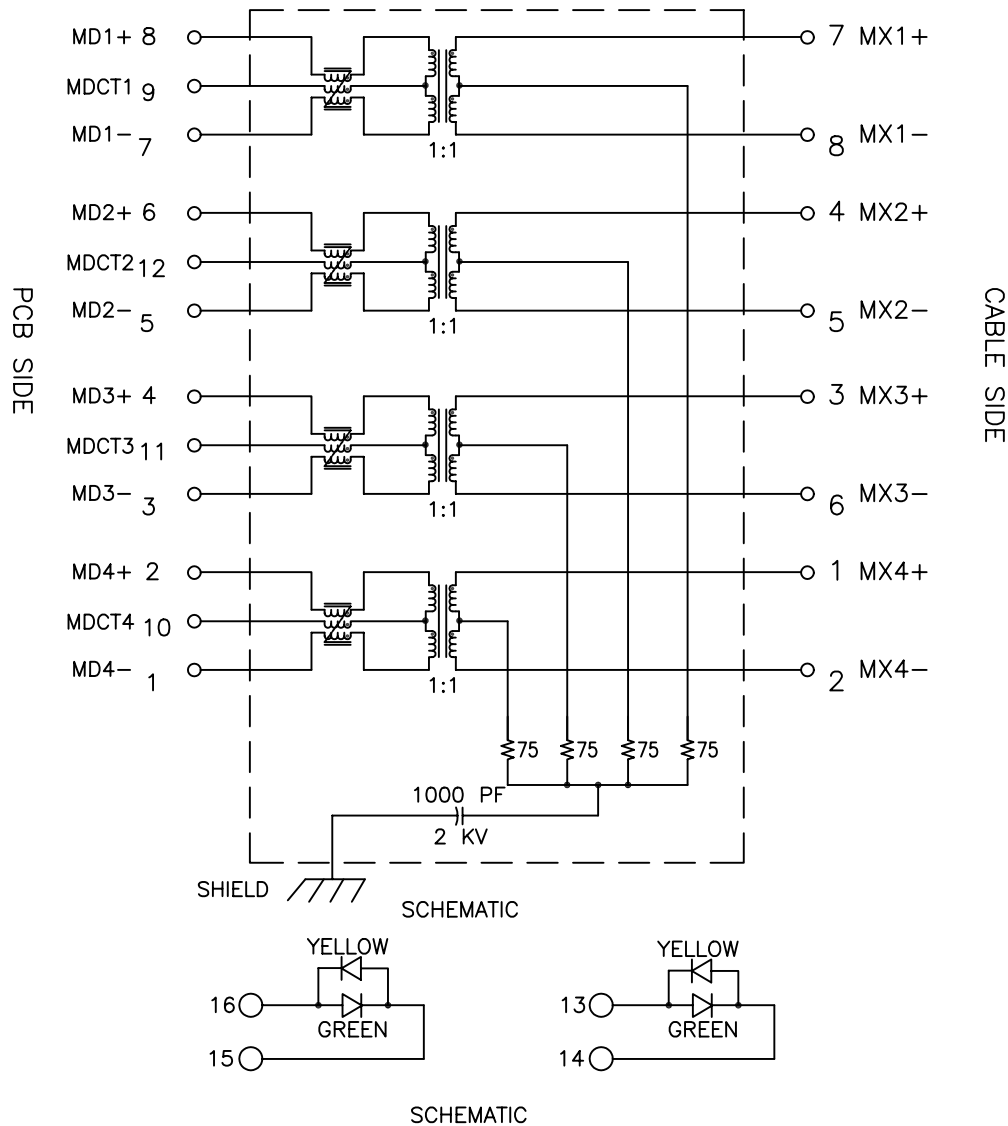

© Copyright, 2014. Pulse Electronics Corp. All rights reserved. Pulse confidential & proprietary. (11/12/14)

PRODUCT DESCRIPTION	TLA DRAWING	PS DRAWING	SHEET	PART NO.	DATASHEET REV.
CONN,RJ45,1X4,10/100/1000,1:1,TD	JON-0011NL-11	PS-2476.008-A	2 OF 5	JON-0011NL	A

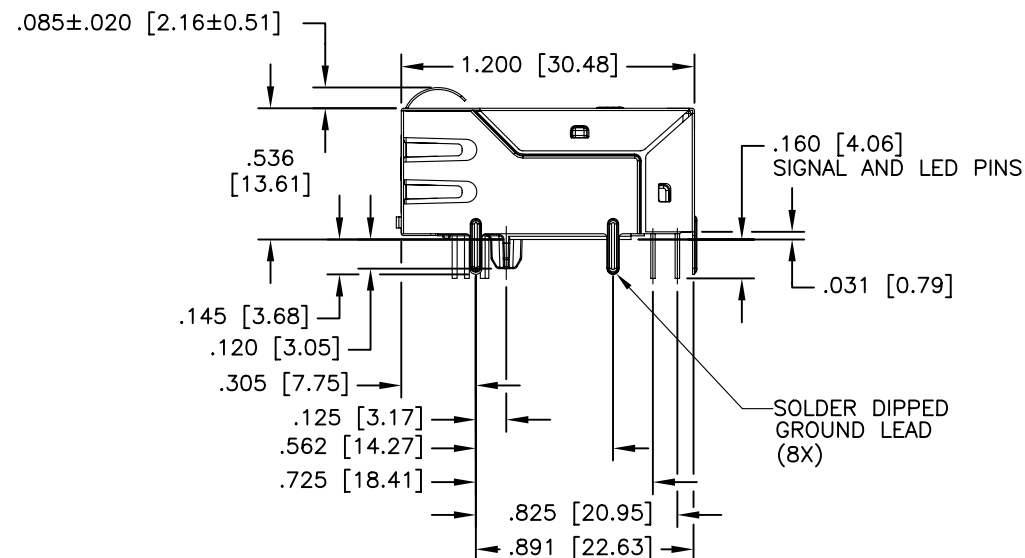
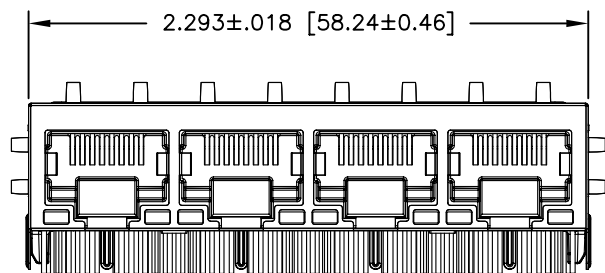
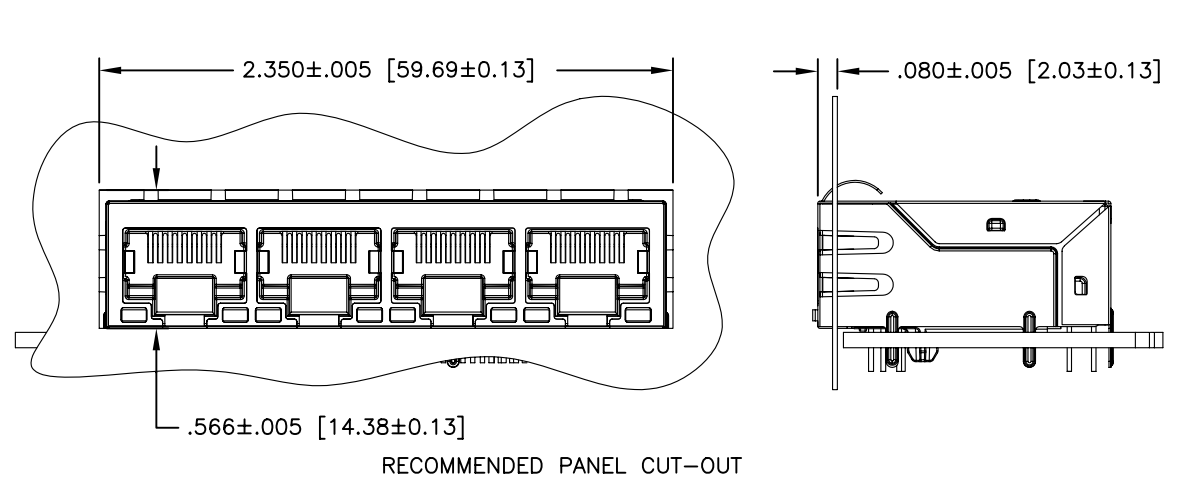
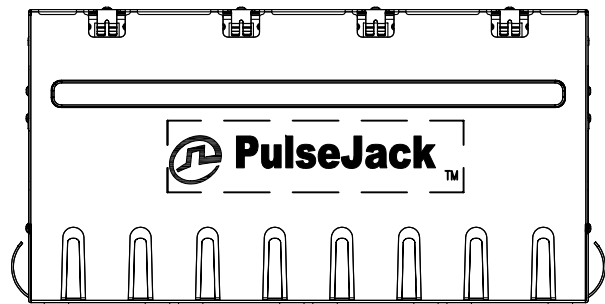

DIMENSIONS ARE IN INCHES [MILLIMETERS] WITH THE FOLLOWING TOLERANCES: [MILLIMETERS] ARE FOR REFERENCE ONLY.

.XX = ±.02 [±0.5]  
.XXX = ±.010 [±0.25]

© Copyright, 2014. Pulse Electronics Corp. All rights reserved. Pulse confidential & proprietary. (11/12/14)

PRODUCT DESCRIPTION	TLA DRAWING	PS DRAWING	SHEET	PART NO.	DATASHEET REV.
CONN,RJ45,1X4,10/100/1000,1:1,TD	JON-0011NL-11	PS-2476.008-A	3 OF 5	JON-0011NL	A

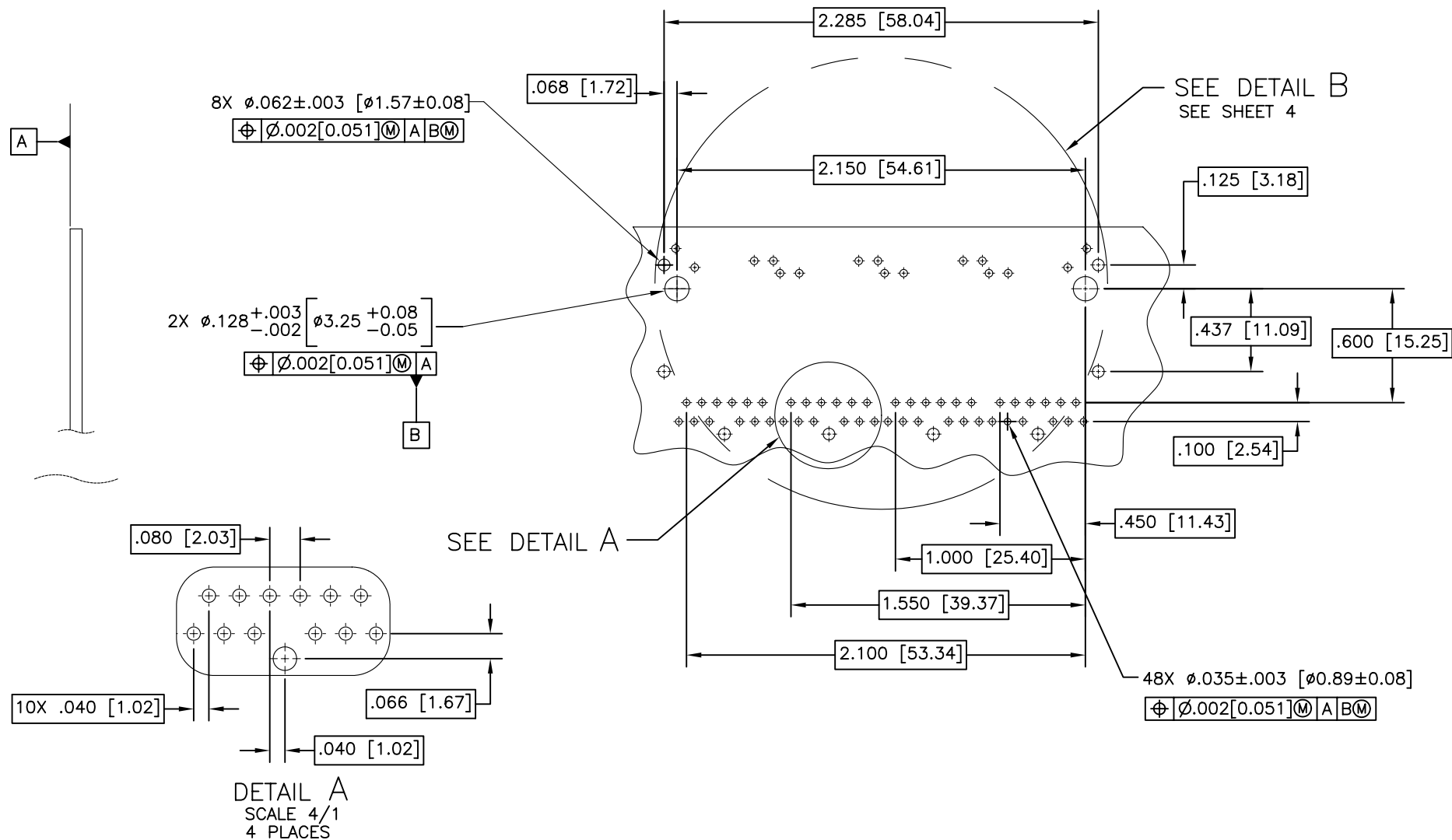

DIMENSIONS ARE IN INCHES [MILLIMETERS] WITH THE FOLLOWING TOLERANCES: [MILLIMETERS] ARE FOR REFERENCE ONLY.  
.XXX= ±.002 [±0.05]

© Copyright, 2014. Pulse Electronics Corp. All rights reserved. Pulse confidential & proprietary. (11/12/14)

PRODUCT DESCRIPTION	TLA DRAWING	PS DRAWING	SHEET	PART NO.	DATASHEET REV.
CONN,RJ45,1X4,10/100/1000,1:1,TD	JON-0011NL-11	PS-2476.008-A	4 OF 5	JON-0011NL	A

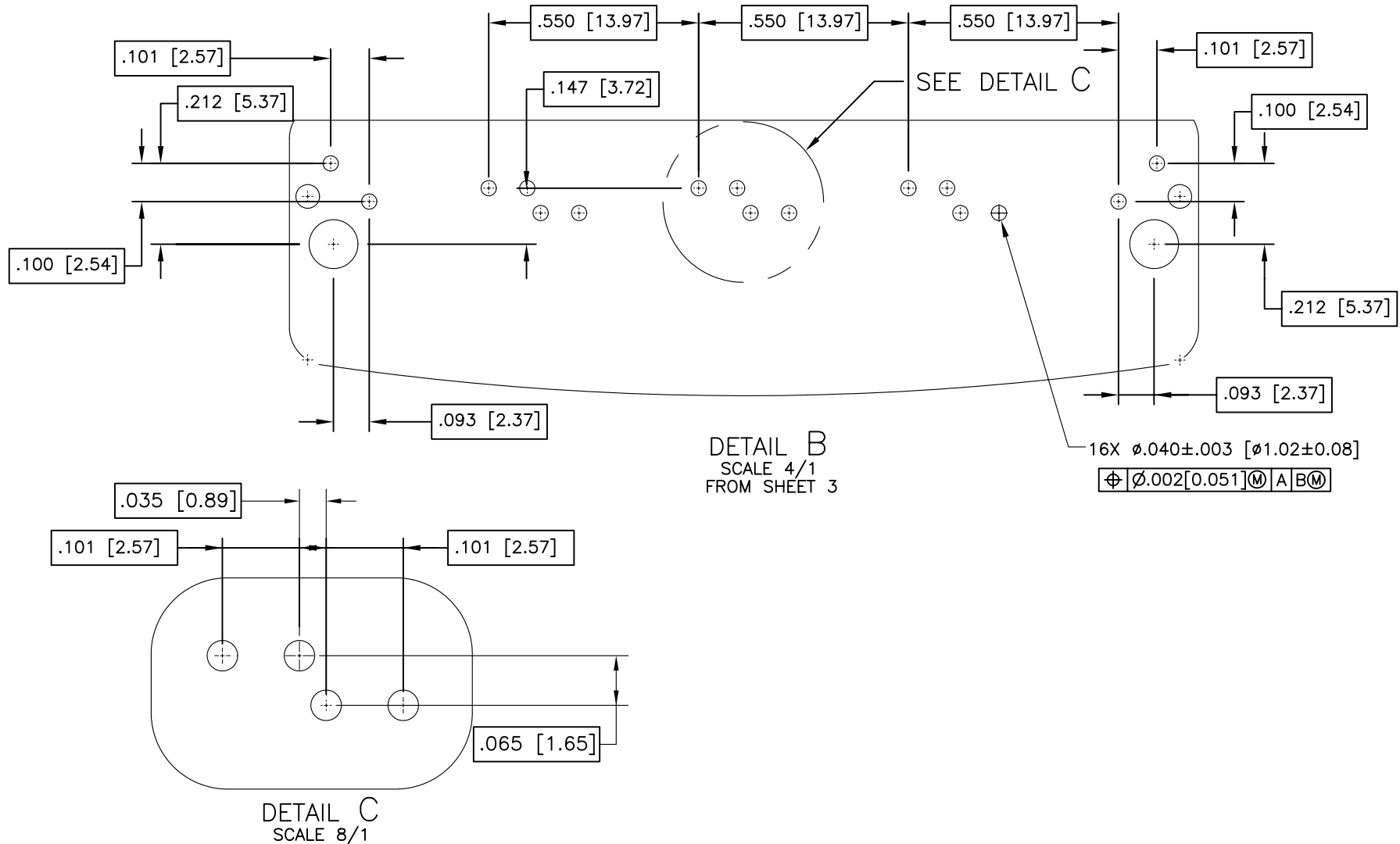

DIMENSIONS ARE IN INCHES [MILLIMETERS] WITH THE FOLLOWING TOLERANCES: [MILLIMETERS] ARE FOR REFERENCE ONLY.  
.XXX= ±.002 [±0.05]

© Copyright, 2014. Pulse Electronics Corp. All rights reserved. Pulse confidential & proprietary. (11/12/14)

PRODUCT DESCRIPTION	TLA DRAWING	PS DRAWING	SHEET	PART NO.	DATASHEET REV.
CONN,RJ45,1X4,10/100/1000,1:1,TD	JON-0011NL-11	PS-2476.008-A	5 OF 5	JON-0011NL	A

# Mouser Electronics

Authorized Distributor

Click to View Pricing, Inventory, Delivery & Lifecycle Information:

Pulse:

[J0N-0011NL](#)