

1595C Enclosure

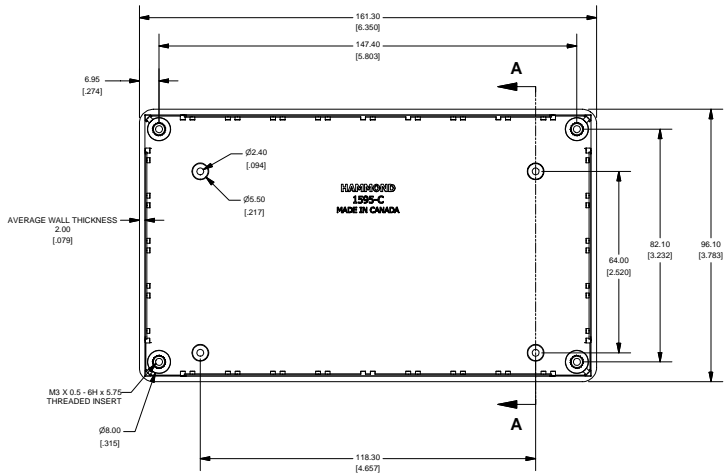

ENCLOSURE

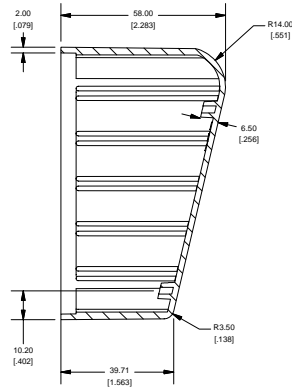

SECTION A-A
SCALE 3/4

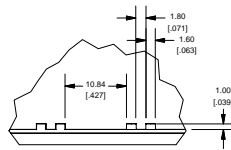

DETAIL B
SCALE 1.50 : 1

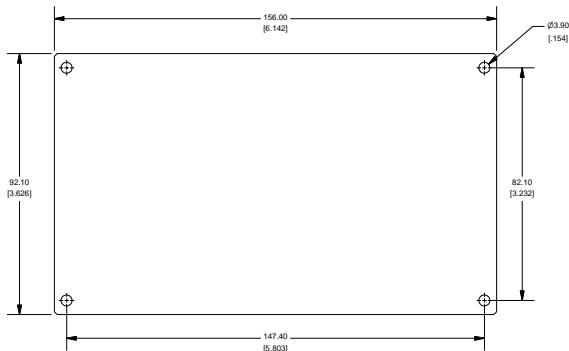

ENCLOSURE LID

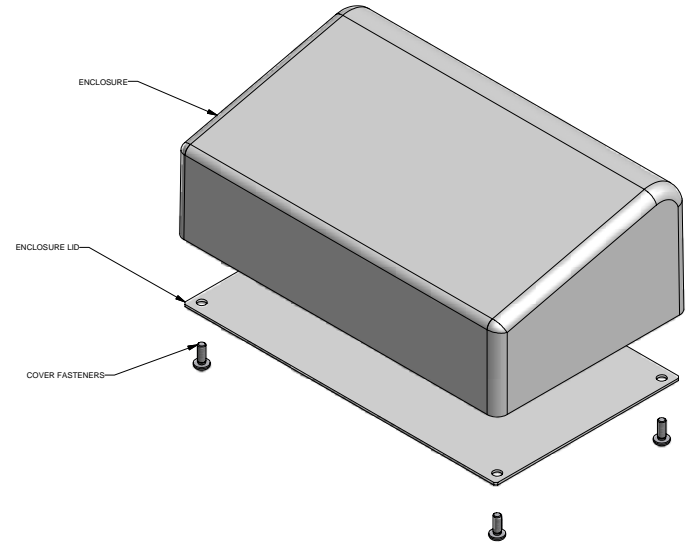
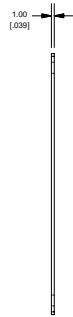

ENCLOSURE ASSEMBLY



VIEW OF INSIDE ENCLOSURE



www.hammondmfg.com

PART NUMBERS		
1595C Enclosures		
Material	Colour	Part Number
ABS	Black	1595CBK
	Grey	1595CGY
Accessories		
	Description	Part Number
	Replacement Screws, machine, M3 - 0.5 x 8mm, Pack of 100,	1595MS100
	Replacement Internal Standoff Screws, #6 X .25" (6.4mm), Pack of 100	1598ATS100

Mouser Electronics

Authorized Distributor

Click to View Pricing, Inventory, Delivery & Lifecycle Information:

[Hammond:](#)

[1595C-BU](#) [1595CBU](#)