

REVISIONS					
P	LTR	DESCRIPTION	DATE	DMN	APVD
AA3		REVISED PER ECR-16-005400	9MAY16	N.L	D.Z

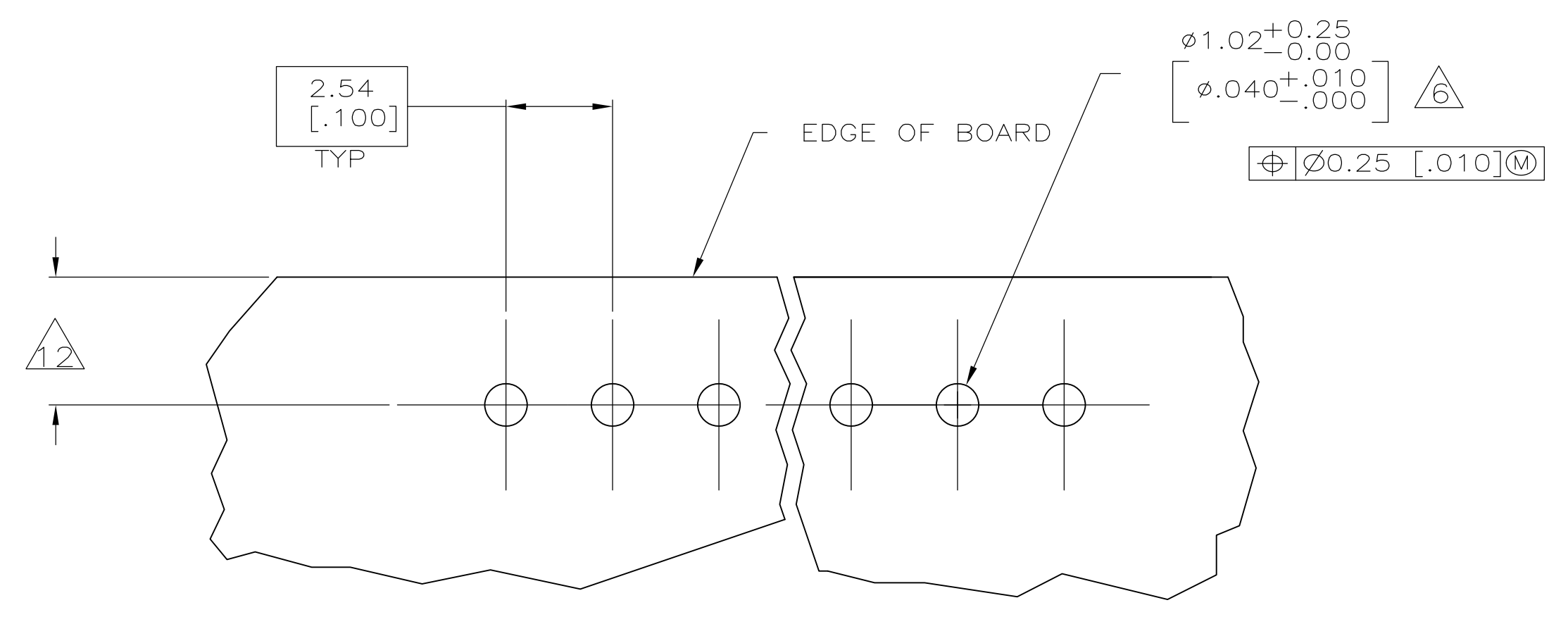
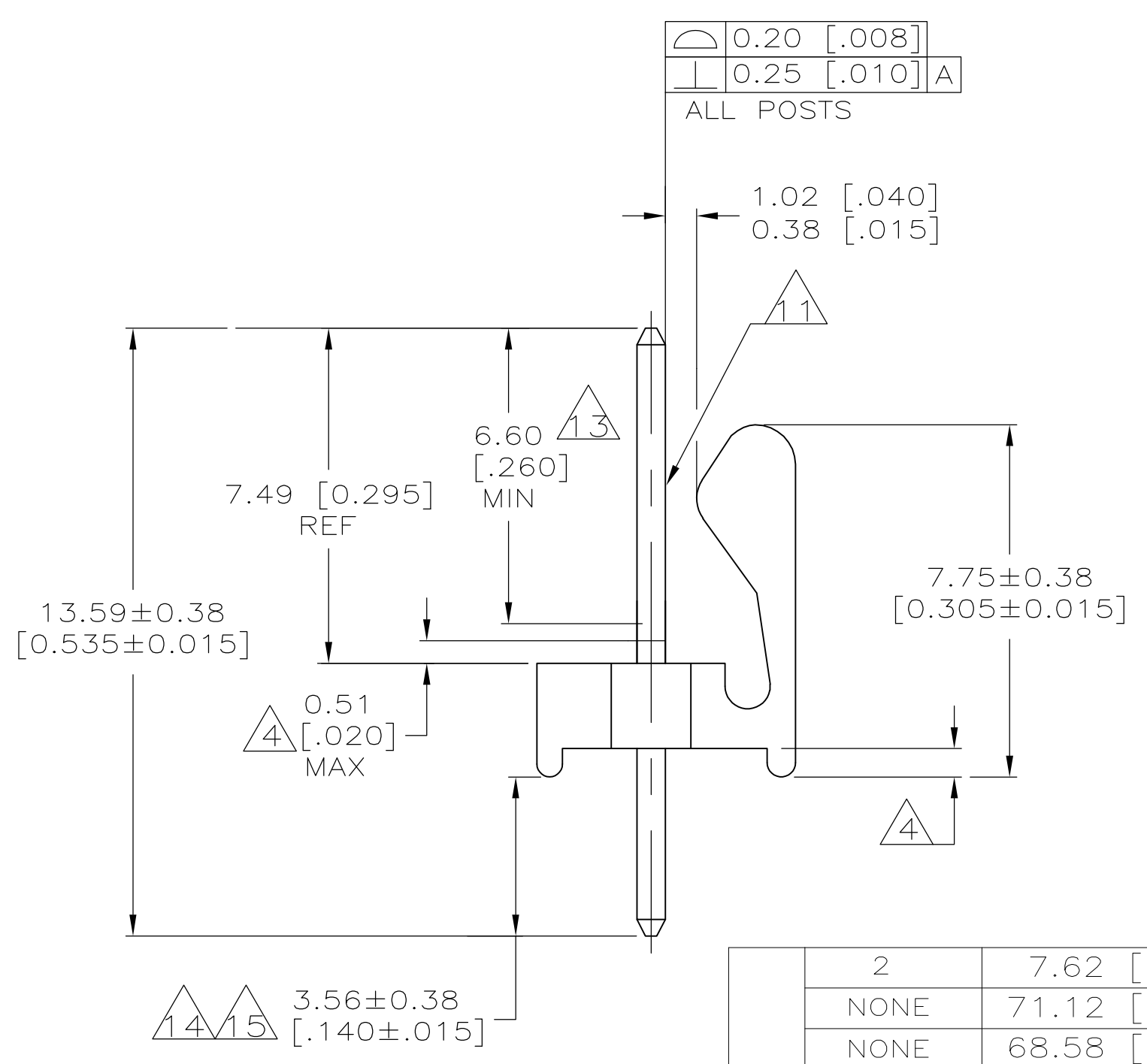
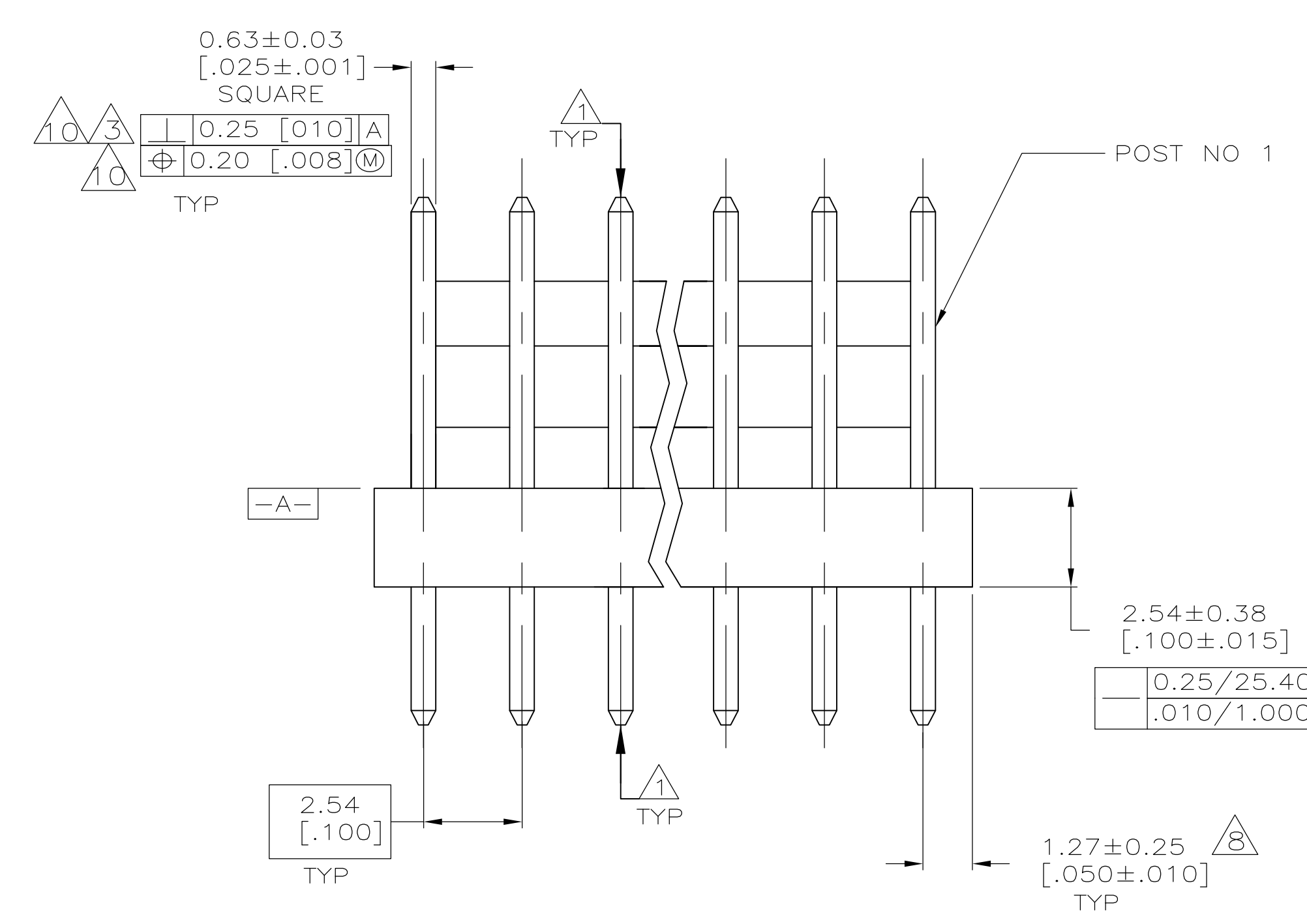
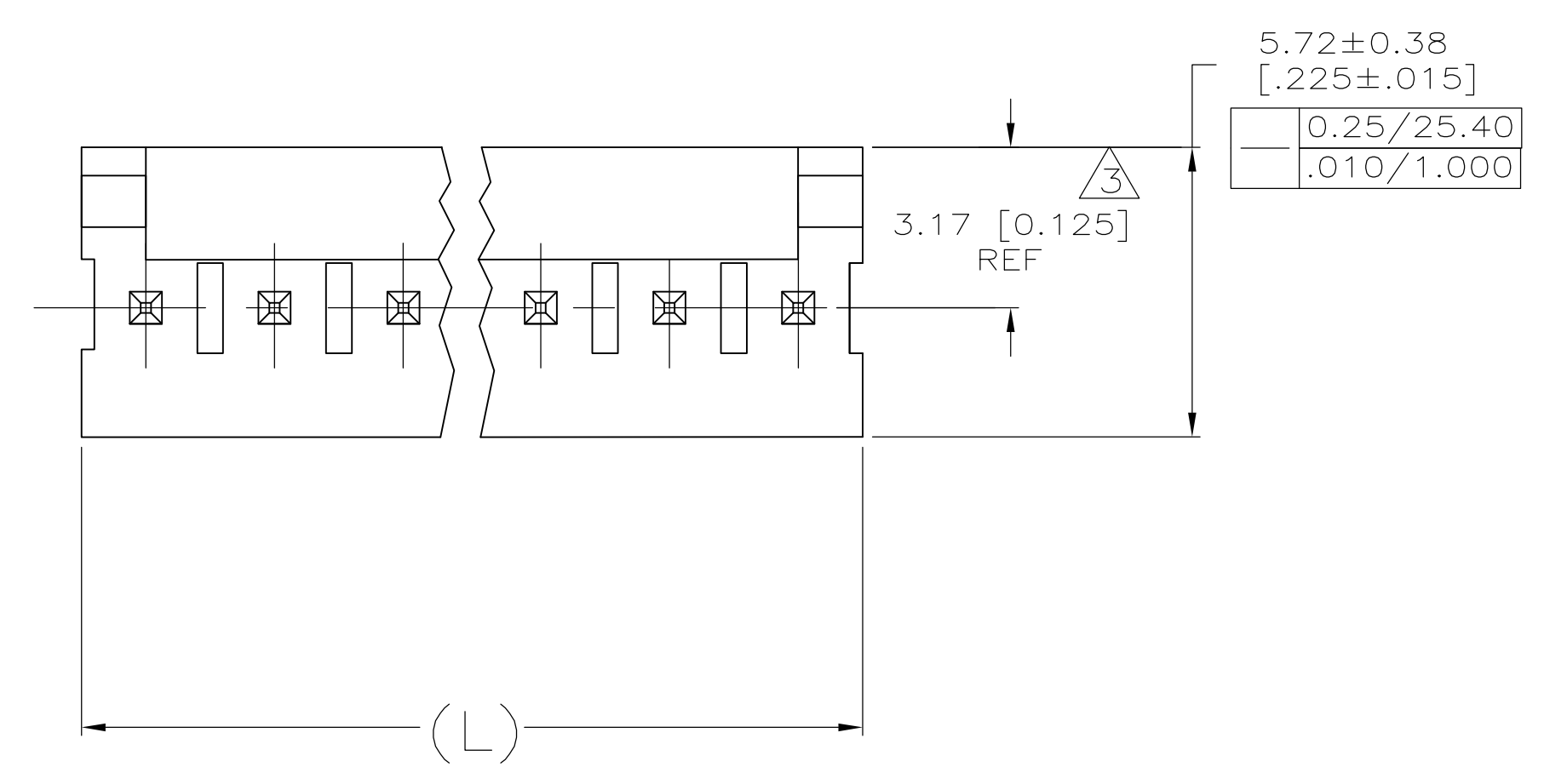

RECOMMENDED MOUNTING HOLE PATTERN FOR 1.60 [.063] THICK P.C. BOARD

- 1 POST TO WITHSTAND 13 NEWTONS (3 LBS) MINIMUM AXIAL FORCE IN BOTH DIRECTIONS SHOWN WITHOUT DISLODGING.
- 2 TOLERANCES APPLY TO SOLDER SIDE OF BOARD.
- 3 MEASURED AT -A-
- 4 PLASTIC FLASH PERMITTED IN THIS AREA.
- 5 PARTS COMPLY WITH AMP SOLDERABILITY SPEC. NO. 109-11-2.
- 6 ONE HOLE MAY BE UNDERSIZED 0.81-0.89 [.032-.035] DIA. FOR ASSEMBLY RETENTION DURING WAVE SOLDERING.
- 7 MATERIAL: HEADER-THERMOPLASTIC POLYESTER  
94V-0 (NATURAL)  
POST-COPPER ALLOY  
FINISH-USE PLATING NOTES 13 & 14 FOR -2 THRU -28  
AND NOTES 13 & 15 FOR -32 THRU -58
- 8 COORDINATE DIMENSION APPLIES FROM CENTER OF ACTUAL FEATURE.
- 9 PLASTIC BURRS CAUSED BY CUT-OFF TOOLING ARE PERMITTED WITHIN THE MAXIMUM TOLERANCE ENVELOPE.
- 10 POSTS TO BE MEASURED WHEN STRIP IS HELD FLAT.
- 11 POST MUST WITHSTAND TWO 90° BENDS AGAINST EXTRUSION WITHOUT BREAKING.
- 12 DIMENSION SHOULD BE 3.30 [.130] MIN WHEN MATING WITH A MTA-100 CONNECTOR ASSEMBLY OR A CST-100 CONNECTOR ASSEMBLY.
- 13 PLATING: GOLD PLATE AREA, 0.00038 [.000015] GOLD OR 0.00008 [.000003] MIN GOLD FLASH OVER 0.00030 [.000012] PALLADIUM NICKEL, PER TE CONNECTIVITY'S DISCRETION, ALL SIDES, OVER NICKEL UNDERPLATE, 0.00127 [.000050] MIN, ALL SIDES AND ENTIRE LENGTH OF POST.
- 14 PLATING: MATTE TIN PLATE AREA, 0.00381-0.00889 [.000150-.000350] THICK, ALL FOUR SIDES 3.56 [.140] MINIMUM.
- 15 PLATING: MATTE TIN PLATE AREA, 0.00381-0.00889 [.000150-.000350] THICK, ALL FOUR SIDES 3.56 [.140] MINIMUM.
- 16 OBSOLETE PARTS: OBSOLETE CIS STREAMLINING PER D.RENAUD/D.SINISI
- 17 PRELIMINARY-NOT FOR PRODUCTION.

LEAD WIRE	2	7.62 [.300]	3	6-641126-3
	NONE	71.12 [2.800]	28	5-641126-8
	NONE	68.58 [2.700]	27	5-641126-7
	NONE	66.04 [2.600]	26	5-641126-6
	NONE	63.50 [2.500]	25	5-641126-5
	NONE	60.96 [2.400]	24	5-641126-4
	NONE	58.42 [2.300]	23	5-641126-3
	NONE	55.88 [2.200]	22	5-641126-2
	NONE	53.34 [2.100]	21	5-641126-1
	NONE	50.80 [2.000]	20	5-641126-0
	NONE	48.26 [1.900]	19	4-641126-9
	NONE	45.72 [1.800]	18	4-641126-8
	NONE	43.18 [1.700]	17	4-641126-7
	NONE	40.64 [1.600]	16	4-641126-6
	NONE	38.10 [1.500]	15	4-641126-5
	NONE	35.56 [1.400]	14	4-641126-4
	NONE	33.02 [1.300]	13	4-641126-3
	NONE	30.48 [1.200]	12	4-641126-2
	NONE	27.94 [1.100]	11	4-641126-1
	NONE	25.40 [1.000]	10	4-641126-0
	NONE	22.86 [.900]	9	3-641126-9
	NONE	20.32 [.800]	8	3-641126-8
	NONE	17.78 [.700]	7	3-641126-7
	NONE	15.24 [.600]	6	3-641126-6
	NONE	12.70 [.500]	5	3-641126-5
	NONE	10.16 [.400]	4	3-641126-4
	NONE	7.62 [.300]	3	3-641126-3
	NONE	5.08 [.200]	2	3-641126-2
OMITTED POST NO.			NO.OF POSN	ASSEMBLY

LEAD WIRE	NONE	71.12 [2.800]	28	2-641126-8	SUPERSEDED BY 5-641126-8
	NONE	68.58 [2.700]	27	2-641126-7	SUPERSEDED BY 5-641126-7
	NONE	66.04 [2.600]	26	2-641126-6	SUPERSEDED BY 5-641126-6
	NONE	63.50 [2.500]	25	2-641126-5	SUPERSEDED BY 5-641126-5
	NONE	60.96 [2.400]	24	2-641126-4	
	NONE	58.42 [2.300]	23	2-641126-3	SUPERSEDED BY 5-641126-3
	NONE	55.88 [2.200]	22	2-641126-2	SUPERSEDED BY 5-641126-2
	NONE	53.34 [2.100]	21	2-641126-1	SUPERSEDED BY 5-641126-1
	NONE	50.80 [2.000]	20	2-641126-0	
	NONE	48.26 [1.900]	19	1-641126-9	SUPERSEDED BY 4-641126-9
	NONE	45.72 [1.800]	18	1-641126-8	
	NONE	43.18 [1.700]	17	1-641126-7	SUPERSEDED BY 4-641126-7
	NONE	40.64 [1.600]	16	1-641126-6	
	NONE	38.10 [1.500]	15	1-641126-5	
	NONE	35.56 [1.400]	14	1-641126-4	
	NONE	33.02 [1.300]	13	1-641126-3	SUPERSEDED BY 4-641126-3
	NONE	30.48 [1.200]	12	1-641126-2	
	NONE	27.94 [1.100]	11	1-641126-1	
	NONE	25.40 [1.000]	10	1-641126-0	
	NONE	22.86 [.900]	9	641126-9	
	NONE	20.32 [.800]	8	641126-8	
	NONE	17.78 [.700]	7	641126-7	
	NONE	15.24 [.600]	6	641126-6	
	NONE	12.70 [.500]	5	641126-5	
	NONE	10.16 [.400]	4	641126-4	
	NONE	7.62 [.300]	3	641126-3	
	NONE	5.08 [.200]	2	641126-2	
OMITTED POST NO.			NO.OF POSN	ASSEMBLY	

METRIC

THIS DRAWING IS A CONTROLLED DOCUMENT.

DIMENSIONS: mm [INCHES]

TOLERANCES UNLESS OTHERWISE SPECIFIED:

0 PLC	±
1 PLC	±
2 PLC	± 0.13 [.005]
3 PLC	±
4 PLC	±
ANGLES	±

MATERIAL: 7 FINISH: 7

APPROVED: S. HOOVER 26-JAN-2005  
D. ROSSI 26-JAN-2005

NAME: MTA100 HDR ASSY, FRICTION LOCK, NOTCHED, .025 SQUARE STRAIGHT POST.

PRODUCT SPEC: 108-1050

APPLICATION SPEC: 114-1019

WEIGHT: 0

CUSTOMER DRAWING: A1 00779

SCALE: N/A SHEET: 1 OF 1 REV: AA3

# Mouser Electronics

Authorized Distributor

Click to View Pricing, Inventory, Delivery & Lifecycle Information:

[TE Connectivity:](#)

[3-641126-4](#)