

THIS DRAWING IS UNPUBLISHED. RELEASED FOR PUBLICATION
 © COPYRIGHT - By - ALL RIGHTS RESERVED.

LOC		DIST		REVISIONS			
P	LTR	DESCRIPTION	DATE	DWN	APVD		
GP	00						
	U2	REVISED PER ECO-12-011709	26JUN2012	RW	SY		

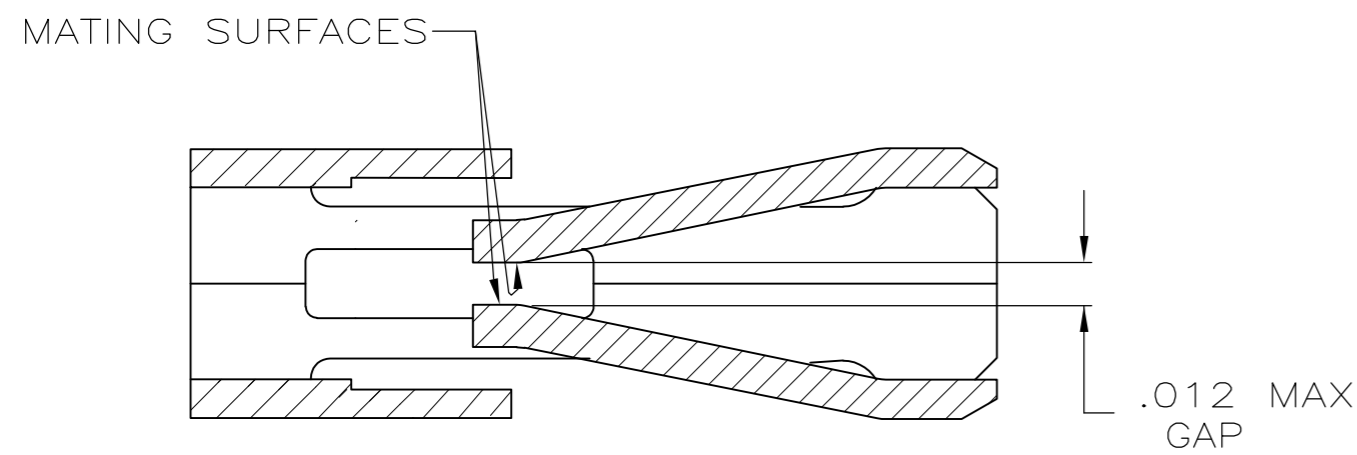

SECTION B-B
SCALE 20:1

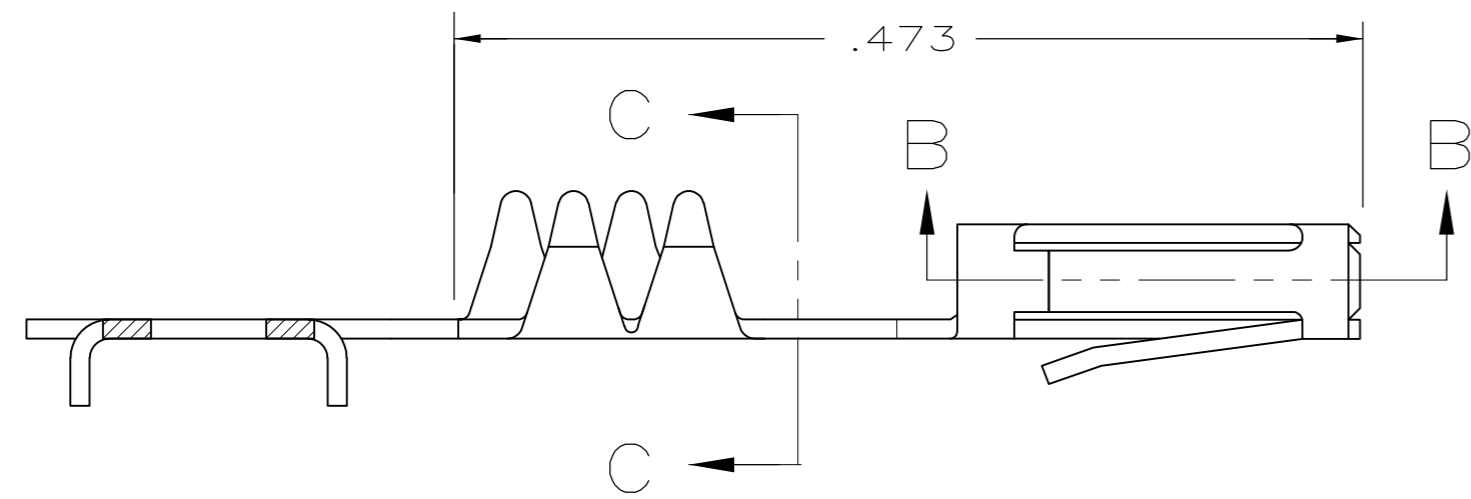
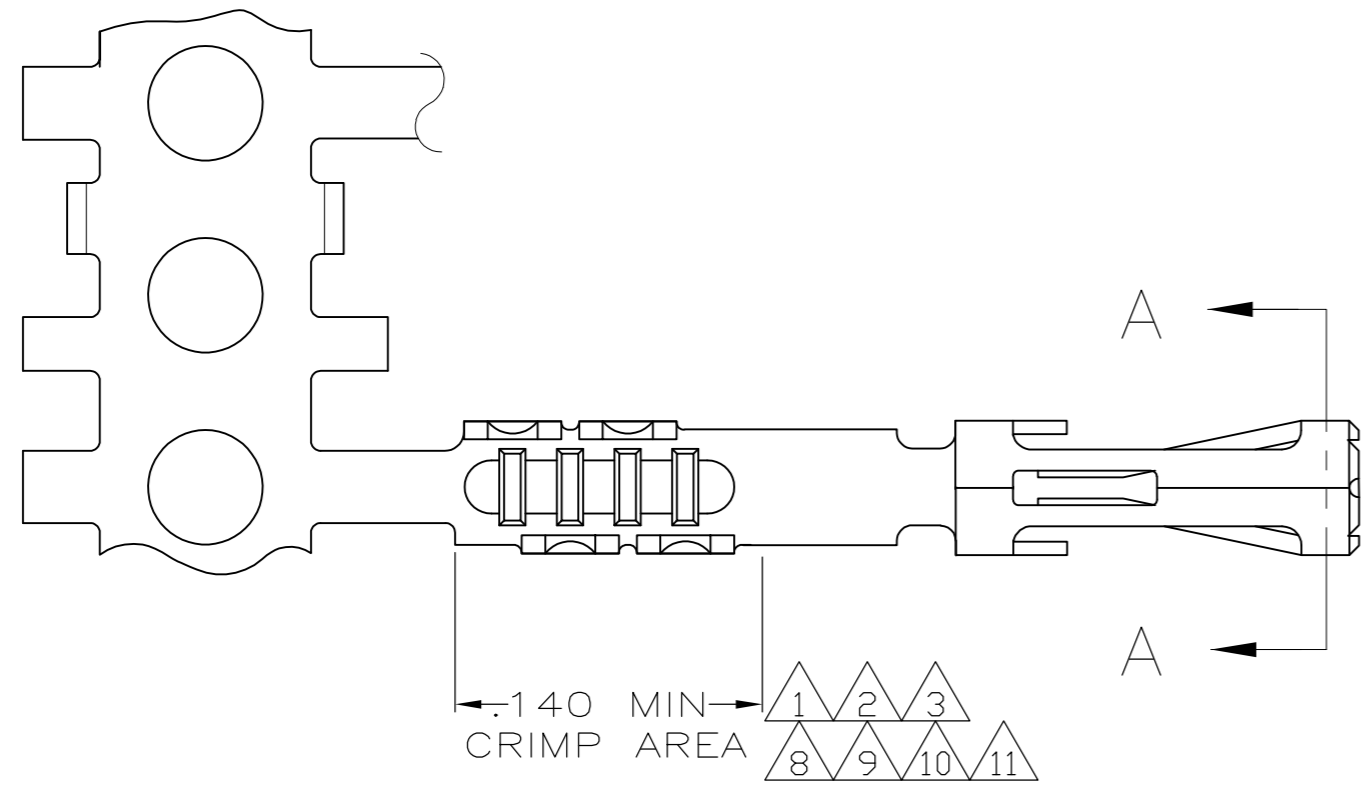
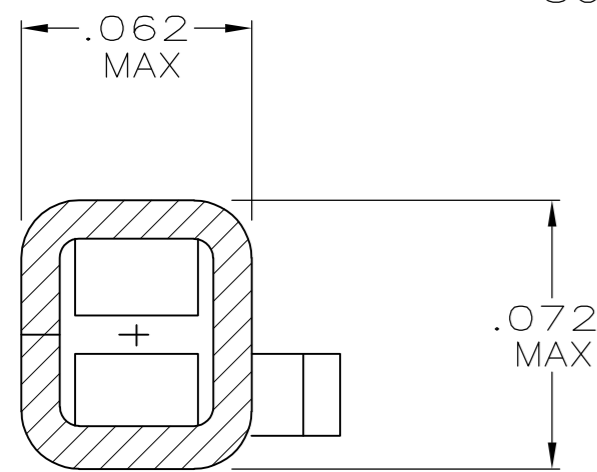

SECTION A-A
SCALE 20:1

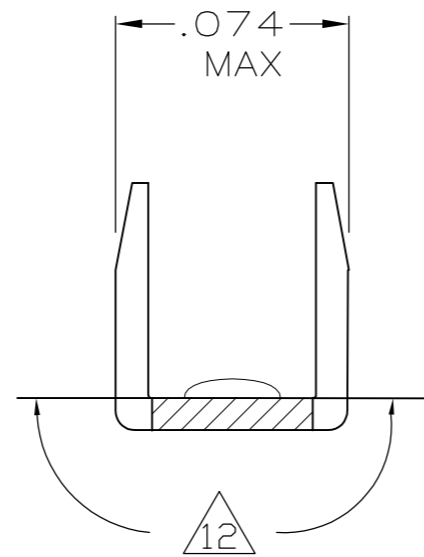

SECTION C-C
SCALE 20:1

SEE NOTES ON SHEET 2

SUPSD BY 487406-2

11	12	2-487406-6
10	12	2-487406-4
9	12	2-487406-3
8	12	2-487406-2
7		1-487406-0
6		487406-9
4		487406-4
3		487406-3
2		487406-2
1		487406-1
FINISH		PART NUMBER

THIS DRAWING IS A CONTROLLED DOCUMENT.		DWN 11-10-84 D.DOLLYHIGH		
DIMENSIONS: INCHES		CHK 11-10-84 J.COMPTON		
TOLERANCES UNLESS OTHERWISE SPECIFIED:		APVD -	NAME	
0 PLC ± -		PRODUCT SPEC	RECEPTACLE CONTACT, STANDARD PRESSURE	
1 PLC ± -		108-9024	-	
2 PLC ± -		APPLICATION SPEC	-	
3 PLC ± .005		114-16015	SIZE	CAGE CODE
4 PLC ± -		WEIGHT -	A2	00779
ANGLES ± -		CUSTOMER DRAWING	DRAWING NO	RESTRICTED TO
FINISH SEE TABLE		SCALE 10:1	C=487406	1 of 2
		SHEET	REV U2	

THIS DRAWING IS UNPUBLISHED. RELEASED FOR PUBLICATION
 © COPYRIGHT - By - ALL RIGHTS RESERVED.

LOC	DIST	REVISIONS					
GP	00	P	LTR	DESCRIPTION	DATE	DWN	APVD
		-	-	SEE SHEET 1	-	-	-

- ① PREPLATED WITH NICKEL UNDERPLATE .000050 THK ON ENTIRE CONTACT WITH GOLD .000015 THK ON MATING AREA AND PLATED WITH BRIGHT TIN-LEAD .000100 THK IN CRIMP AREA,
-OR-
NICKEL .000050 MIN THK UNDERPLATE ON ENTIRE CONTACT, GOLD FLASH OVER PALLADIUM-NICKEL, .000015 MIN TOTAL THK ON MATING SURFACES AND BRIGHT TIN/LEAD .000100 MIN THK IN CRIMP AREA.
- ② PREPLATED WITH NICKEL UNDERPLATE .000050 THK ON ENTIRE CONTACT WITH GOLD .000030 THK ON MATING AREA AND PLATED WITH BRIGHT TIN-LEAD .000100 THK IN CRIMP AREA,
-OR-
NICKEL .000050 MIN THK UNDERPLATE ON ENTIRE CONTACT, GOLD FLASH OVER PALLADIUM-NICKEL, .000030 MIN TOTAL THK ON MATING AREA AND BRIGHT TIN/LEAD .000100 MIN THK ON CRIMP AREA.
- ③ PREPLATED WITH NICKEL UNDERPLATE .000050 THK ON ENTIRE CONTACT WITH GOLD .000050 THK ON MATING AREA AND PLATED WITH BRIGHT TIN-LEAD .000100 THK IN CRIMP AREA,
-OR-
NICKEL .000050 MIN THK UNDERPLATE ON ENTIRE CONTACT, GOLD FLASH OVER PALLADIUM-NICKEL, .000050 MIN TOTAL THK ON MATING AREA AND BRIGHT TIN/LEAD .000100 MIN THK ON CRIMP AREA.
- ④ .000100 BRIGHT TIN-LEAD OVER .000050 PRE-PLATED NICKEL UNDERPLATE ON ENTIRE CONTACT.
- 5. MATING POST LENGTH ACCEPTED:
SINGLE ROW HOUSINGS .220-.323
DOUBLE ROW HOUSINGS .235-.323
- ⑥ PREPLATED WITH NICKEL UNDERPLATE .000050 THK ON ENTIRE CONTACT WITH GOLD .000050 THK ON MATING AREA AND GOLD FLASH OVER ENTIRE CONTACT,
-OR-
NICKEL .000050 MIN THK UNDERPLATE ON ENTIRE CONTACT, GOLD FLASH OVER PALLADIUM-NICKEL, .000050 MIN TOTAL THK ON MATING AREA AND GOLD FLASH OVER ENTIRE CONTACT.
- ⑦ PREPLATED WITH NICKEL UNDERPLATE .000050 THK ON ENTIRE CONTACT WITH GOLD .000030 THK ON MATING AREA AND PLATED WITH GOLD .000030 THK ON ENTIRE CONTACT EXCEPT .000003 MIN THK PERMISSIBLE ON INTERIOR OF CONTACT BOX EXCLUSIVE OF MATING AREA.
- ⑧ PREPLATED WITH NICKEL UNDERPLATE .000050 MIN THK ON ENTIRE CONTACT WITH GOLD .000015 MIN THK ON MATING AREA AND PLATED WITH GOLD FLASH IN CRIMP AREA,
-OR-
NICKEL .000050 MIN THK UNDERPLATE ON ENTIRE CONTACT, GOLD FLASH OVER PALLADIUM-NICKEL, .000015 MIN TOTAL THK ON MATING AREA AND GOLD FLASH IN CRIMP AREA.
- ⑨ PREPLATED WITH NICKEL UNDERPLATE .000050 MIN THK ON ENTIRE CONTACT WITH GOLD .000030 MIN THK ON MATING AREA AND PLATED WITH GOLD FLASH IN CRIMP AREA,
-OR-
NICKEL .000050 MIN THK UNDERPLATE ON ENTIRE CONTACT, GOLD FLASH OVER PALLADIUM-NICKEL, .000030 MIN TOTAL THK ON MATING AREA AND GOLD FLASH IN CRIMP AREA.
- ⑩ PRE-PLATED WITH NICKEL UNDERPLATE .000050 THICK ON ENTIRE CONTACT WITH GOLD FLASH IN CRIMP AREA AND .000100 MIN TIN ON MATING AREA.
- ⑪ PRE-PLATED WITH NICKEL UNDERPLATE .000050 THICK ON ENTIRE CONTACT WITH GOLD .000050 THICK ON MATING AREA AND PLATED WITH GOLD FLASH IN CRIMP AREA,
-OR-
NICKEL .000050 MIN THK UNDERPLATE ON ENTIRE CONTACT, GOLD FLASH OVER PALLADIUM-NICKEL, .000050 MIN TOTAL THK ON MATING AREA AND GOLD FLASH IN CRIMP AREA.
- ⑫ GOLD PLATING MAY OR MAY NOT BE PRESENT ON THE BOTTOM OF THE CRIMP BARREL IN THIS AREA.

487406

THIS DRAWING IS A CONTROLLED DOCUMENT.		DWN D.DOLLYHIGH 11-10-84	TE TE Connectivity	
DIMENSIONS: INCHES		CHK J.COMPTON 11-10-84		
TOLERANCES UNLESS OTHERWISE SPECIFIED:		APVD -	NAME	
		PRODUCT SPEC 108-9024	RECEPTACLE CONTACT, STANDARD PRESSURE	
MATERIAL PHOSPHOR BRONZE		APPLICATION SPEC 114-16015	SIZE A2	CAGE CODE 00779
FINISH SEE TABLE		WEIGHT -	DRAWING NO C=487406	RESTRICTED TO -
CUSTOMER DRAWING			SCALE 10:1	SHEET 2 of 2
			REV U2	

Mouser Electronics

Authorized Distributor

Click to View Pricing, Inventory, Delivery & Lifecycle Information:

[TE Connectivity:](#)

[487406-1](#)