

Very low drop voltage regulator with inhibit function

Datasheet - production data

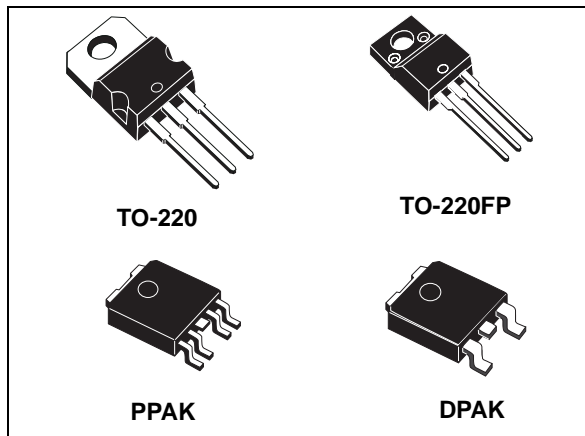

Description

The LFXX is a very low drop regulator available in TO-220, TO-220FP, DPAK and PPAK packages and in a wide range of output voltages. The low drop voltage (0.45 V) and low quiescent current make it particularly suitable for low-noise, low-power applications and especially in battery-powered systems. In the 5 pin configuration (PPAK) a shutdown logic control function is available (pin 2, TTL compatible). This means that when the device is used as a local regulator, a part of the board can be put in standby, decreasing the total power consumption. In the three terminal configuration, the device has the same electrical performance, but it is fixed in ON state. It requires a capacitor of only 2.2 μF for stability, saving board space and costs. The LFXX is available as automotive grade in DPAK and PPAK packages, for the options of output voltages whose commercial part numbers are shown in the order codes. These devices are qualified according to the specification AEC-Q100 of the automotive market, in the temperature range -40 °C to 125 °C, and the statistical tests PAT, SYL, SBL are performed.

Features

- Very low-dropout voltage (0.45 V)
- Very low quiescent current (typ. 50 μA in OFF mode, 500 μA in ON mode)
- Output current up to 500 mA
- Logic-controlled electronic shutdown
- Output voltages of 1.5; 1.8; 2.5; 3.3; 4.7; 5; 6; 8; 8.5; 9; 12 V
- Automotive grade product: 1.8 V, 2.5 V, 3.3 V, 5.0 V, 8.0 V, 8.5 V V_{OUT} in DPAK and PPAK packages
- Internal current and thermal limit
- Only 2.2 μF for stability
- Available in $\pm 1\%$ (AB) or $\pm 2\%$ (C) selection at 25 °C
- Supply voltage rejection: 80 db (typ.)
- Temperature range: from -40 to 125 °C

Contents

1	Diagram	5
2	Pin configuration	6
3	Maximum ratings	7
4	Electrical characteristics	8
5	Typical performance characteristics	34
6	Package information	38
6.1	TO-220 package information	39
6.2	TO-220 packing information	44
6.3	DPAK package information	45
6.4	PPAK package information	47
6.5	DPAK and PPAK packing information	49
7	Ordering information	51
8	Revision history	52

List of tables

Table 1.	Absolute maximum ratings	7
Table 2.	Thermal data	7
Table 3.	LF15AB electrical characteristics	8
Table 4.	LF18AB electrical characteristics	9
Table 5.	LF18C electrical characteristics	10
Table 6.	LF18C (automotive grade) electrical characteristics.	11
Table 7.	LF25AB electrical characteristics	12
Table 8.	LF25AB (automotive grade) electrical characteristics.	13
Table 9.	LF25C electrical characteristics	14
Table 10.	LF25C (automotive grade) electrical characteristics.	15
Table 11.	LF33AB electrical characteristics	16
Table 12.	LF33C electrical characteristics	17
Table 13.	LF33C (automotive grade) electrical characteristics.	18
Table 14.	LF50AB electrical characteristics	19
Table 15.	LF50AB (automotive grade) electrical characteristics.	20
Table 16.	LF50C electrical characteristics	21
Table 17.	LF50C (automotive grade) electrical characteristics.	22
Table 18.	LF60AB electrical characteristics	23
Table 19.	LF60C electrical characteristics	24
Table 20.	LF80AB electrical characteristics	25
Table 21.	LF80C electrical characteristics	26
Table 22.	LF80C (automotive grade) electrical characteristics.	27
Table 23.	LF85AB electrical characteristics	28
Table 24.	LF85C electrical characteristics	29
Table 25.	LF85C (automotive grade) electrical characteristics.	30
Table 26.	LF90C electrical characteristics	31
Table 27.	LF120AB electrical characteristics	32
Table 28.	LF120C electrical characteristics	33
Table 29.	TO-220 mechanical data	41
Table 30.	TO-220FP mechanical data	43
Table 31.	DPAK mechanical data.	46
Table 32.	PPAK mechanical data.	48
Table 33.	DPAK and PPAK tape and reel mechanical data	50
Table 34.	Order code	51
Table 35.	Document revision history	52

List of figures

Figure 1.	Block diagram	5
Figure 2.	Pin connections (top view)	6
Figure 3.	Test circuit	7
Figure 4.	Dropout voltage vs. output current	34
Figure 5.	Dropout voltage vs. temperature	34
Figure 6.	Supply current vs. input voltage	34
Figure 7.	Supply current vs. input voltage (no load)	34
Figure 8.	Short-circuit current vs. input voltage	34
Figure 9.	Supply current vs. temperature.	34
Figure 10.	Logic-controlled precision 3.3/5.0 V selectable output	35
Figure 11.	Sequential multi-output supply	35
Figure 12.	Multiple supply with ON/OFF toggle switch	36
Figure 13.	Basic inhibit functions	36
Figure 14.	Delayed turn-on	37
Figure 15.	Low voltage bulb blinker	37
Figure 16.	TO-220 (STD-ST dual gauge) package outline	39
Figure 17.	TO-220 (STD-ST single gauge) package outline	40
Figure 18.	TO-220FP package outline.	42
Figure 19.	TO-220 dual gauge tube outline (dimensions in mm)	44
Figure 20.	TO-220 single gauge tube outline(dimensions in mm)	44
Figure 21.	DPAK package outline	45
Figure 22.	DPAK recommended footprint	46
Figure 23.	PPAK package outline	47
Figure 24.	DPAK and PPAK tape outline.	49
Figure 25.	DPAK and PPAK reel outline	50

1 Diagram

Figure 1. Block diagram

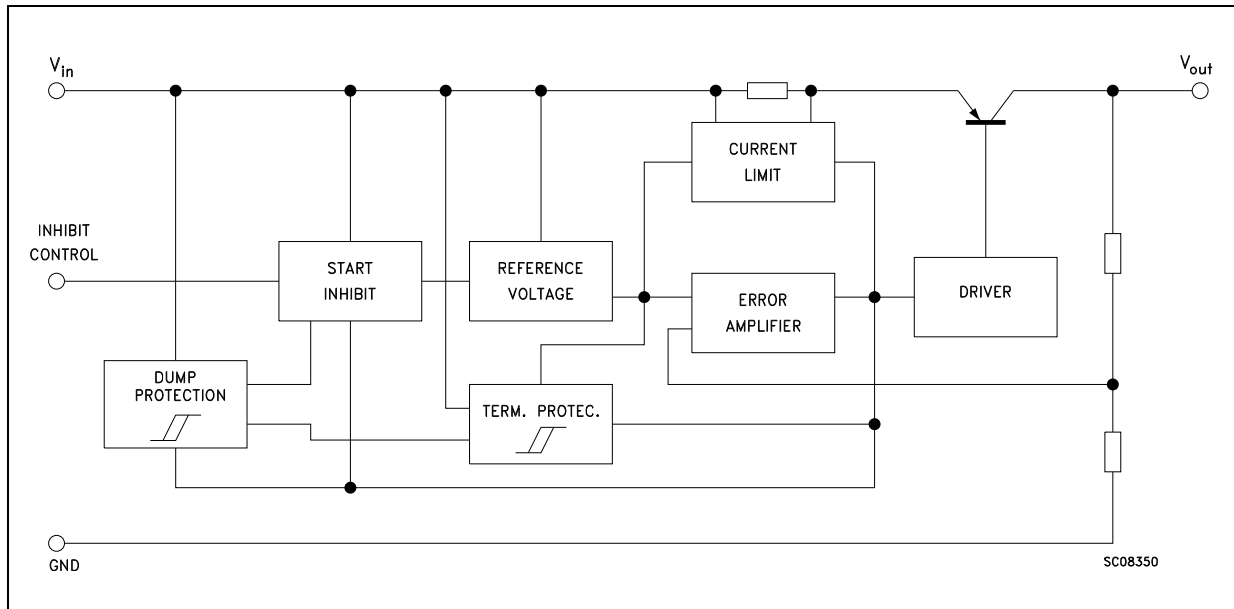

2 Pin configuration

Figure 2. Pin connections (top view)

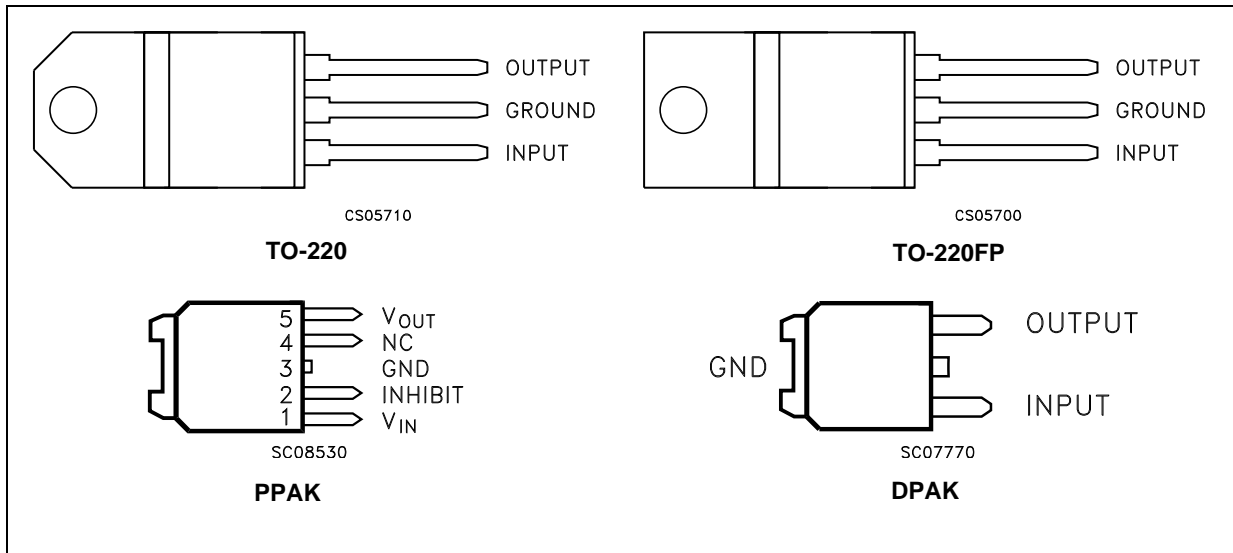

Note: TAB is electrically connected to GND on TO-220, PPAK and DPAK packages

3 Maximum ratings

Table 1. Absolute maximum ratings

Symbol	Parameter	Value	Unit
V_I	DC input voltage	-0.5 to 40 ⁽¹⁾	V
I_O	Output current	Internally limited	A
P_{TOT}	Power dissipation	Internally limited	W
T_{STG}	Storage temperature range	-40 to 150	°C
T_{OP}	Operating junction temperature range	-40 to 125	°C

1. For $18 < V_I < 40$ the regulator is in shutdown.

Table 2. Thermal data

Symbol	Parameter	TO-220	TO-220FP	DPAK/PPAK	Unit
R_{thJC}	Thermal resistance junction-case	5	5	8	°C/W
R_{thJA}	Thermal resistance junction-ambient	50	60	100	°C/W

Figure 3. Test circuit

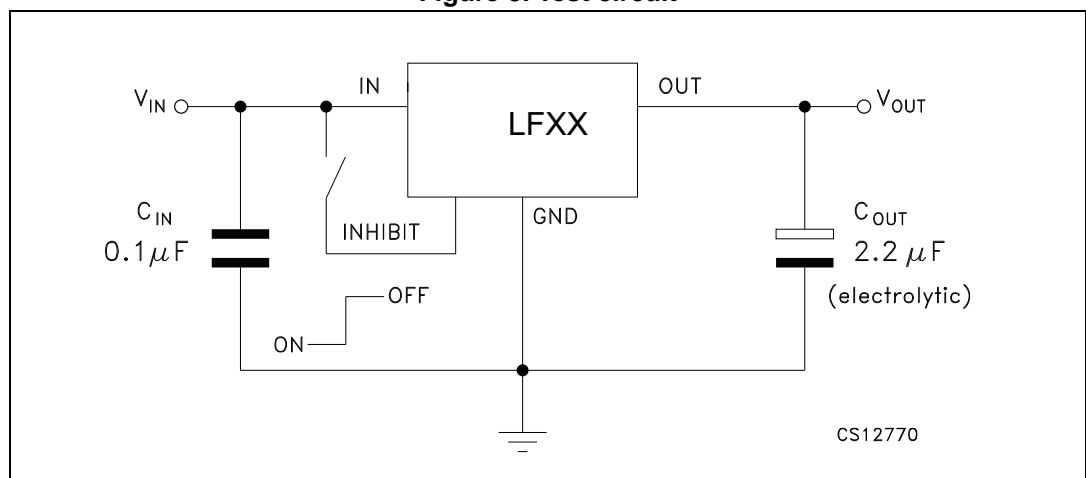

4 Electrical characteristics

Refer to test circuits, $T_J = 25\text{ °C}$, $C_I = 0.1\text{ }\mu\text{F}$, $C_O = 2.2\text{ }\mu\text{F}$ unless otherwise specified.

Table 3. LF15AB electrical characteristics

Symbol	Parameter	Test conditions	Min.	Typ.	Max.	Unit
V_O	Output voltage	$I_O = 50\text{ mA}$, $V_I = 3.5\text{ V}$	1.485	1.5	1.515	V
		$I_O = 50\text{ mA}$, $V_I = 3.5\text{ V}$, $T_a = -25\text{ to }85\text{ °C}$	1.470		1.530	
V_I	Operating input voltage	$I_O = 500\text{ mA}$	2.5		16	V
I_O	Output current limit			1		A
ΔV_O	Line regulation	$V_I = 2.5\text{ to }16\text{ V}$, $I_O = 5\text{ mA}$		2	10	mV
ΔV_O	Load regulation	$V_I = 2.8\text{ V}$, $I_O = 5\text{ to }500\text{ mA}$		2	10	mV
I_d	Quiescent current	$V_I = 2.5\text{ to }16\text{ V}$, $I_O = 0\text{ mA}$		0.5	1	mA
		$V_I = 2.8\text{ to }16\text{ V}$, $I_O = 500\text{ mA}$				
		$V_I = 6\text{ V}$	OFF mode	50	100	
SVR	Supply voltage rejection	$I_O = 5\text{ mA}$, $V_I = 3.5 \pm 1\text{ V}$	$f = 120\text{ Hz}$		82	dB
			$f = 1\text{ kHz}$		77	
			$f = 10\text{ kHz}$		65	
eN	Output noise voltage	$B = 10\text{ Hz to }100\text{ kHz}$		50		μV
V_d	Dropout voltage	$I_O = 200\text{ mA}$		1		V
V_{IL}	Control input logic low	$T_a = -40\text{ to }125\text{ °C}$			0.8	V
V_{IH}	Control input logic high	$T_a = -40\text{ to }125\text{ °C}$	2			V
I_I	Control input current	$V_I = 6\text{ V}$, $V_C = 6\text{ V}$		10		μA
C_O	Output bypass capacitance	$\text{ESR} = 0.1\text{ to }10\text{ }\Omega$, $I_O = 0\text{ to }500\text{ mA}$	2	10		μF

Refer to test circuits, $T_J = 25\text{ °C}$, $C_I = 0.1\text{ }\mu\text{F}$, $C_O = 2.2\text{ }\mu\text{F}$ unless otherwise specified.

Table 4. LF18AB electrical characteristics

Symbol	Parameter	Test conditions	Min.	Typ.	Max.	Unit
V_O	Output voltage	$I_O = 50\text{ mA}$, $V_I = 3.3\text{ V}$	1.782	1.8	1.818	V
		$I_O = 50\text{ mA}$, $V_I = 3.3\text{ V}$, $T_a = -25\text{ to }85\text{ °C}$	1.764		1.836	
V_I	Operating input voltage	$I_O = 500\text{ mA}$	3		16	V
I_O	Output current limit			1		A
ΔV_O	Line regulation	$V_I = 2.8\text{ to }16\text{ V}$, $I_O = 5\text{ mA}$		2	12	mV
ΔV_O	Load regulation	$V_I = 3.3\text{ V}$, $I_O = 5\text{ to }500\text{ mA}$		2	10	mV
I_d	Quiescent current	$V_I = 2.5\text{ to }16\text{ V}$, $I_O = 0\text{ mA}$	ON mode	0.5	1	mA
		$V_I = 3.1\text{ to }16\text{ V}$, $I_O = 500\text{ mA}$				
		$V_I = 6\text{ V}$	OFF mode	50	100	
SVR	Supply voltage rejection	$I_O = 5\text{ mA}$, $V_I = 3.5 \pm 1\text{ V}$	$f = 120\text{ Hz}$		82	dB
			$f = 1\text{ kHz}$		77	
			$f = 10\text{ kHz}$		60	
eN	Output noise voltage	$B = 10\text{ Hz to }100\text{ kHz}$		50		μV
V_d	Dropout voltage	$I_O = 200\text{ mA}$		0.7		V
V_{IL}	Control input logic low	$T_a = -40\text{ to }125\text{ °C}$			0.8	V
V_{IH}	Control input logic high	$T_a = -40\text{ to }125\text{ °C}$	2			V
I_I	Control input current	$V_I = 6\text{ V}$, $V_C = 6\text{ V}$		10		μA
C_O	Output bypass capacitance	$\text{ESR} = 0.1\text{ to }10\text{ }\Omega$, $I_O = 0\text{ to }500\text{ mA}$	2	10		μF

Refer to test circuits, $T_J = 25\text{ }^\circ\text{C}$, $C_I = 0.1\text{ }\mu\text{F}$, $C_O = 2.2\text{ }\mu\text{F}$ unless otherwise specified.

Table 5. LF18C electrical characteristics

Symbol	Parameter	Test conditions	Min.	Typ.	Max.	Unit
V_O	Output voltage	$I_O = 50\text{ mA}$, $V_I = 3.5\text{ V}$	1.764	1.8	1.836	V
		$I_O = 50\text{ mA}$, $V_I = 3.5\text{ V}$, $T_a = -25\text{ to }85\text{ }^\circ\text{C}$	1.728		1.872	
V_I	Operating input voltage	$I_O = 500\text{ mA}$	3		16	V
I_O	Output current limit			1		A
ΔV_O	Line regulation	$V_I = 2.8\text{ to }16\text{ V}$, $I_O = 5\text{ mA}$		2	12	mV
ΔV_O	Load regulation	$V_I = 3.3\text{ V}$, $I_O = 5\text{ to }500\text{ mA}$		2	10	mV
I_d	Quiescent current	$V_I = 2.5\text{ to }16\text{ V}$, $I_O = 0\text{ mA}$	ON mode	0.5	1	mA
		$V_I = 3.1\text{ to }16\text{ V}$, $I_O = 500\text{ mA}$				
		$V_I = 6\text{ V}$	OFF mode	50	100	
SVR	Supply voltage rejection	$I_O = 5\text{ mA}$, $V_I = 3.5 \pm 1\text{ V}$	f = 120 Hz		82	dB
			f = 1 kHz		77	
			f = 10 kHz		60	
eN	Output noise voltage	B = 10 Hz to 100 kHz		50		μV
V_d	Dropout voltage	$I_O = 200\text{ mA}$		0.7		V
V_{IL}	Control input logic low	$T_a = -40\text{ to }125\text{ }^\circ\text{C}$			0.8	V
V_{IH}	Control input logic high	$T_a = -40\text{ to }125\text{ }^\circ\text{C}$	2			V
I_I	Control input current	$V_I = 6\text{ V}$, $V_C = 6\text{ V}$		10		μA
C_O	Output bypass capacitance	ESR = 0.1 to 10 Ω , $I_O = 0\text{ to }500\text{ mA}$	2	10		μF

Refer to test circuits, $T_a = -40$ to 125 °C, $C_1 = 0.1$ μ F, $C_O = 2.2$ μ F unless otherwise specified.

Table 6. LF18C (automotive grade) electrical characteristics

Symbol	Parameter	Test conditions	Min.	Typ.	Max.	Unit
V_O	Output voltage	$I_O = 50$ mA, $V_I = 3.5$ V, $T_a = 25$ °C	1.764	1.8	1.836	V
		$I_O = 50$ mA, $V_I = 3.5$ V	1.713		1.887	
V_I	Operating input voltage	$I_O = 500$ mA	3		16	V
I_O	Output current limit	$T_a = 25$ °C		1		A
ΔV_O	Line regulation	$V_I = 2.8$ to 16 V, $I_O = 5$ mA		2	15	mV
ΔV_O	Load regulation	$V_I = 3.3$ V, $I_O = 5$ to 500 mA		2	15	mV
I_d	Quiescent current	$V_I = 2.5$ to 16 V, $I_O = 0$ mA	ON mode	0.5	2	mA
		$V_I = 3.1$ to 16 V, $I_O = 500$ mA				
		$V_I = 6$ V	OFF mode	50	120	
SVR	Supply voltage rejection	$I_O = 5$ mA, $V_I = 3.5 \pm 1$ V $T_a = 25$ °C	f = 120 Hz		82	dB
			f = 1 kHz		77	
			f = 10 kHz		60	
eN	Output noise voltage	B = 10 Hz to 100 kHz, $T_a = 25$ °C		50		μ V
V_d	Dropout voltage	$I_O = 200$ mA		0.2	1.3	V
		$I_O = 500$ mA		0.4	1.3	
V_{IL}	Control input logic low				0.8	V
V_{IH}	Control input logic high		2			V
I_I	Control input current	$V_I = 6$ V, $V_C = 6$ V, $T_a = 25$ °C		10		μ A
C_O	Output bypass capacitance	ESR = 0.1 to 10 Ω , $I_O = 0$ to 500 mA	2	10		μ F

Refer to test circuits, $T_J = 25\text{ °C}$, $C_I = 0.1\text{ }\mu\text{F}$, $C_O = 2.2\text{ }\mu\text{F}$ unless otherwise specified.

Table 7. LF25AB electrical characteristics

Symbol	Parameter	Test conditions	Min.	Typ.	Max.	Unit
V_O	Output voltage	$I_O = 50\text{ mA}$, $V_I = 4.5\text{ V}$	2.475	2.5	2.525	V
		$I_O = 50\text{ mA}$, $V_I = 4.5\text{ V}$, $T_a = -25\text{ to }85\text{ °C}$	2.450		2.550	
V_I	Operating input voltage	$I_O = 500\text{ mA}$			16	V
I_O	Output current limit			1		A
ΔV_O	Line regulation	$V_I = 3.5\text{ to }16\text{ V}$, $I_O = 5\text{ mA}$		2	12	mV
ΔV_O	Load regulation	$V_I = 3.8\text{ V}$, $I_O = 5\text{ to }500\text{ mA}$		2	12	mV
I_d	Quiescent current	$V_I = 3.5\text{ to }16\text{ V}$, $I_O = 0\text{ mA}$	ON mode	0.5	1	mA
		$V_I = 3.8\text{ to }16\text{ V}$, $I_O = 500\text{ mA}$			12	
		$V_I = 6\text{ V}$	OFF mode	50	100	μA
SVR	Supply voltage rejection	$I_O = 5\text{ mA}$, $V_I = 4.5 \pm 1\text{ V}$	f = 120 Hz		82	dB
			f = 1 kHz		77	
			f = 10 kHz		65	
eN	Output noise voltage	B = 10 Hz to 100 kHz		50		μV
V_d	Dropout voltage	$I_O = 200\text{ mA}$		0.2	0.35	V
		$I_O = 500\text{ mA}$		0.4	0.7	
V_{IL}	Control input logic low	$T_a = -40\text{ to }125\text{ °C}$			0.8	V
V_{IH}	Control input logic high	$T_a = -40\text{ to }125\text{ °C}$	2			V
I_I	Control input current	$V_I = 6\text{ V}$, $V_C = 6\text{ V}$		10		μA
C_O	Output bypass capacitance	ESR = 0.1 to 10 Ω , $I_O = 0\text{ to }500\text{ mA}$	2	10		μF

Refer to test circuits, $T_a = -40$ to 125 °C, $C_I = 0.1$ μ F, $C_O = 2.2$ μ F unless otherwise specified.

Table 8. LF25AB (automotive grade) electrical characteristics

Symbol	Parameter	Test conditions	Min.	Typ.	Max.	Unit
V_O	Output voltage	$I_O = 50$ mA, $V_I = 4.5$ V, $T_a = 25$ °C	2.475	2.5	2.525	V
		$I_O = 50$ mA, $V_I = 4.5$ V	2.435		2.565	
V_I	Operating input voltage	$I_O = 500$ mA			16	V
I_O	Output current limit	$T_a = 25$ °C		1		A
ΔV_O	Line regulation	$V_I = 3.5$ to 16 V, $I_O = 5$ mA		2	15	mV
ΔV_O	Load regulation	$V_I = 3.8$ V, $I_O = 5$ to 500 mA		2	15	mV
I_d	Quiescent current	$V_I = 3.5$ to 16 V, $I_O = 0$ mA	ON mode	0.5	2	mA
		$V_I = 3.8$ to 16 V, $I_O = 500$ mA				
		$V_I = 6$ V	OFF mode	50	120	
SVR	Supply voltage rejection	$I_O = 5$ mA, $V_I = 4.5 \pm 1$ V $T_a = 25$ °C	f = 120 Hz		82	dB
			f = 1 kHz		77	
			f = 10 kHz		65	
eN	Output noise voltage	B = 10 Hz to 100 kHz, $T_a = 25$ °C		50		μ V
V_d	Dropout voltage	$I_O = 200$ mA		0.2	1.3	V
		$I_O = 500$ mA		0.4	1.3	
V_{IL}	Control input logic low				0.8	V
V_{IH}	Control input logic high		2			V
I_I	Control input current	$V_I = 6$ V, $V_C = 6$ V, $T_a = 25$ °C		10		μ A
C_O	Output bypass capacitance	ESR = 0.1 to 10 Ω , $I_O = 0$ to 500 mA	2	10		μ F

Refer to test circuits, $T_J = 25\text{ }^\circ\text{C}$, $C_I = 0.1\text{ }\mu\text{F}$, $C_O = 2.2\text{ }\mu\text{F}$ unless otherwise specified.

Table 9. LF25C electrical characteristics

Symbol	Parameter	Test conditions	Min.	Typ.	Max.	Unit	
V_O	Output voltage	$I_O = 50\text{ mA}$, $V_I = 4.5\text{ V}$	2.45	2.5	2.55	V	
		$I_O = 50\text{ mA}$, $V_I = 4.5\text{ V}$, $T_a = -25\text{ to }85\text{ }^\circ\text{C}$	2.4		2.6		
V_I	Operating input voltage	$I_O = 500\text{ mA}$			16	V	
I_O	Output current limit			1		A	
ΔV_O	Line regulation	$V_I = 3.5\text{ to }16\text{ V}$, $I_O = 5\text{ mA}$		2	12	mV	
ΔV_O	Load regulation	$V_I = 3.8\text{ V}$, $I_O = 5\text{ to }500\text{ mA}$		2	12	mV	
I_d	Quiescent current	$V_I = 3.5\text{ to }16\text{ V}$, $I_O = 0\text{ mA}$	ON mode		0.5	1	mA
		$V_I = 3.8\text{ to }16\text{ V}$, $I_O = 500\text{ mA}$				12	
		$V_I = 6\text{ V}$	OFF mode		50	100	μA
SVR	Supply voltage rejection	$I_O = 5\text{ mA}$, $V_I = 4.5 \pm 1\text{ V}$	f = 120 Hz		82	dB	
			f = 1 kHz		77		
			f = 10 kHz		65		
eN	Output noise voltage	B = 10 Hz to 100 kHz		50		μV	
V_d	Dropout voltage	$I_O = 200\text{ mA}$		0.2	0.35	V	
		$I_O = 500\text{ mA}$		0.4	0.7		
V_{IL}	Control input logic low	$T_a = -40\text{ to }125\text{ }^\circ\text{C}$			0.8	V	
V_{IH}	Control input logic high	$T_a = -40\text{ to }125\text{ }^\circ\text{C}$	2			V	
I_I	Control input current	$V_I = 6\text{ V}$, $V_C = 6\text{ V}$		10		μA	
C_O	Output bypass capacitance	ESR = 0.1 to 10 Ω , $I_O = 0\text{ to }500\text{ mA}$	2	10		μF	

Refer to test circuits, $T_a = -40$ to 125 °C, $C_I = 0.1$ μ F, $C_O = 2.2$ μ F unless otherwise specified.

Table 10. LF25C (automotive grade) electrical characteristics

Symbol	Parameter	Test conditions	Min.	Typ.	Max.	Unit
V_O	Output voltage	$I_O = 50$ mA, $V_I = 4.5$ V, $T_a = 25$ °C	2.45	2.5	2.55	V
		$I_O = 50$ mA, $V_I = 4.5$ V	2.385		2.615	
V_I	Operating input voltage	$I_O = 500$ mA			16	V
I_O	Output current limit	$T_a = 25$ °C		1		A
ΔV_O	Line regulation	$V_I = 3.5$ to 16 V, $I_O = 5$ mA		2	15	mV
ΔV_O	Load regulation	$V_I = 3.8$ V, $I_O = 5$ to 500 mA		2	15	mV
I_d	Quiescent current	$V_I = 3.5$ to 16 V, $I_O = 0$ mA	ON mode	0.5	2	mA
		$V_I = 3.8$ to 16 V, $I_O = 500$ mA			12	
		$V_I = 6$ V	OFF mode	50	120	μ A
SVR	Supply voltage rejection	$I_O = 5$ mA, $V_I = 4.5 \pm 1$ V $T_a = 25$ °C	f = 120 Hz	82		dB
			f = 1 kHz	77		
			f = 10 kHz	65		
eN	Output noise voltage	B = 10 Hz to 100 kHz, $T_a = 25$ °C		50		μ V
V_d	Dropout voltage	$I_O = 200$ mA		0.2	1.3	V
		$I_O = 500$ mA		0.4	1.3	
V_{IL}	Control input logic low				0.8	V
V_{IH}	Control input logic high		2			V
I_I	Control input current	$V_I = 6$ V, $V_C = 6$ V, $T_a = 25$ °C		10		μ A
C_O	Output bypass capacitance	ESR = 0.1 to 10 Ω , $I_O = 0$ to 500 mA	2	10		μ F

Refer to test circuits, $T_J = 25\text{ °C}$, $C_I = 0.1\text{ }\mu\text{F}$, $C_O = 2.2\text{ }\mu\text{F}$ unless otherwise specified.

Table 11. LF33AB electrical characteristics

Symbol	Parameter	Test conditions	Min.	Typ.	Max.	Unit
V_O	Output voltage	$I_O = 50\text{ mA}$, $V_I = 5.3\text{ V}$	3.267	3.3	3.333	V
		$I_O = 50\text{ mA}$, $V_I = 5.3\text{ V}$, $T_a = -25\text{ to }85\text{ °C}$	3.234		3.366	
V_I	Operating input voltage	$I_O = 500\text{ mA}$			16	V
I_O	Output current limit			1		A
ΔV_O	Line regulation	$V_I = 4.3\text{ to }16\text{ V}$, $I_O = 5\text{ mA}$		3	16	mV
ΔV_O	Load regulation	$V_I = 4.6\text{ V}$, $I_O = 5\text{ to }500\text{ mA}$		3	16	mV
I_d	Quiescent current	$V_I = 4.3\text{ to }16\text{ V}$, $I_O = 0\text{ mA}$	ON mode	0.5	1	mA
		$V_I = 4.6\text{ to }16\text{ V}$, $I_O = 500\text{ mA}$			12	
		$V_I = 6\text{ V}$	OFF mode	50	100	μA
SVR	Supply voltage rejection	$I_O = 5\text{ mA}$, $V_I = 5.3 \pm 1\text{ V}$	$f = 120\text{ Hz}$		80	dB
			$f = 1\text{ kHz}$		75	
			$f = 10\text{ kHz}$		65	
eN	Output noise voltage	$B = 10\text{ Hz to }100\text{ kHz}$		50		μV
V_d	Dropout voltage	$I_O = 200\text{ mA}$		0.2	0.35	V
		$I_O = 500\text{ mA}$		0.4	0.7	
V_{IL}	Control input logic low	$T_a = -40\text{ to }125\text{ °C}$			0.8	V
V_{IH}	Control input logic high	$T_a = -40\text{ to }125\text{ °C}$	2			V
I_I	Control input current	$V_I = 6\text{ V}$, $V_C = 6\text{ V}$		10		μA
C_O	Output bypass capacitance	$\text{ESR} = 0.1\text{ to }10\text{ }\Omega$, $I_O = 0\text{ to }500\text{ mA}$	2	10		μF

Refer to test circuits, $T_J = 25\text{ °C}$, $C_I = 0.1\text{ }\mu\text{F}$, $C_O = 2.2\text{ }\mu\text{F}$ unless otherwise specified.

Table 12. LF33C electrical characteristics

Symbol	Parameter	Test conditions	Min.	Typ.	Max.	Unit
V_O	Output voltage	$I_O = 50\text{ mA}$, $V_I = 5.3\text{ V}$	3.234	3.3	3.366	V
		$I_O = 50\text{ mA}$, $V_I = 5.3\text{ V}$, $T_a = -25\text{ to }85\text{ °C}$	3.168		3.432	
V_I	Operating input voltage	$I_O = 500\text{ mA}$			16	V
I_O	Output current limit			1		A
ΔV_O	Line regulation	$V_I = 4.3\text{ to }16\text{ V}$, $I_O = 5\text{ mA}$		3	16	mV
ΔV_O	Load regulation	$V_I = 4.6\text{ V}$, $I_O = 5\text{ to }500\text{ mA}$		3	16	mV
I_d	Quiescent current	$V_I = 4.3\text{ to }16\text{ V}$, $I_O = 0\text{ mA}$	ON mode	0.5	1	mA
		$V_I = 4.6\text{ to }16\text{ V}$, $I_O = 500\text{ mA}$			12	
		$V_I = 6\text{ V}$	OFF mode	50	100	μA
SVR	Supply voltage rejection	$I_O = 5\text{ mA}$, $V_I = 5.3 \pm 1\text{ V}$	f = 120 Hz		80	dB
			f = 1 kHz		75	
			f = 10 kHz		65	
eN	Output noise voltage	B = 10 Hz to 100 kHz		50		μV
V_d	Dropout voltage	$I_O = 200\text{ mA}$		0.2	0.35	V
		$I_O = 500\text{ mA}$		0.4	0.7	
V_{IL}	Control input logic low	$T_a = -40\text{ to }125\text{ °C}$			0.8	V
V_{IH}	Control input logic high	$T_a = -40\text{ to }125\text{ °C}$	2			V
I_I	Control input current	$V_I = 6\text{ V}$, $V_C = 6\text{ V}$		10		μA
C_O	Output bypass capacitance	ESR = 0.1 to 10 Ω , $I_O = 0\text{ to }500\text{ mA}$	2	10		μF

Refer to test circuits, $T_a = -40$ to $125\text{ }^\circ\text{C}$, $C_1 = 0.1\text{ }\mu\text{F}$, $C_O = 2.2\text{ }\mu\text{F}$ unless otherwise specified.

Table 13. LF33C (automotive grade) electrical characteristics

Symbol	Parameter	Test conditions	Min.	Typ.	Max.	Unit
V_O	Output voltage	$I_O = 50\text{ mA}$, $V_I = 5.3\text{ V}$, $T_a = 25\text{ }^\circ\text{C}$	3.234	3.3	3.366	V
		$I_O = 50\text{ mA}$, $V_I = 5.3\text{ V}$,	3.153		3.447	
V_I	Operating input voltage	$I_O = 500\text{ mA}$			16	V
I_O	Output current limit	$T_a = 25\text{ }^\circ\text{C}$		1		A
ΔV_O	Line regulation	$V_I = 4.3$ to 16 V , $I_O = 5\text{ mA}$		3	19	mV
ΔV_O	Load regulation	$V_I = 4.6\text{ V}$, $I_O = 5$ to 500 mA		3	19	mV
I_d	Quiescent current	$V_I = 4.3$ to 16 V , $I_O = 0\text{ mA}$	ON mode	0.5	2	mA
		$V_I = 4.6$ to 16 V , $I_O = 500\text{ mA}$			12	
		$V_I = 6\text{ V}$	OFF mode	50	120	μA
SVR	Supply voltage rejection	$I_O = 5\text{ mA}$, $V_I = 5.3 \pm 1\text{ V}$ $T_a = 25\text{ }^\circ\text{C}$	$f = 120\text{ Hz}$	80		dB
			$f = 1\text{ kHz}$	75		
			$f = 10\text{ kHz}$	65		
eN	Output noise voltage	$B = 10\text{ Hz}$ to 100 kHz , $T_a = 25\text{ }^\circ\text{C}$		50		μV
V_d	Dropout voltage	$I_O = 200\text{ mA}$		0.2	1.3	V
		$I_O = 500\text{ mA}$		0.4	1.3	
V_{IL}	Control input logic low				0.8	V
V_{IH}	Control input logic high		2			V
I_I	Control input current	$V_I = 6\text{ V}$, $V_C = 6\text{ V}$, $T_a = 25\text{ }^\circ\text{C}$		10		μA
C_O	Output bypass capacitance	$\text{ESR} = 0.1$ to $10\text{ }\Omega$, $I_O = 0$ to 500 mA	2	10		μF

Refer to test circuits, $T_J = 25\text{ °C}$, $C_I = 0.1\text{ }\mu\text{F}$, $C_O = 2.2\text{ }\mu\text{F}$ unless otherwise specified.

Table 14. LF50AB electrical characteristics

Symbol	Parameter	Test conditions	Min.	Typ.	Max.	Unit
V_O	Output voltage	$I_O = 50\text{ mA}$, $V_I = 7\text{ V}$	4.95	5	5.05	V
		$I_O = 50\text{ mA}$, $V_I = 7\text{ V}$, $T_a = -25\text{ to }85\text{ °C}$	4.9		5.1	
V_I	Operating input voltage	$I_O = 500\text{ mA}$			16	V
I_O	Output current limit			1		A
ΔV_O	Line regulation	$V_I = 6\text{ to }16\text{ V}$, $I_O = 5\text{ mA}$		5	25	mV
ΔV_O	Load regulation	$V_I = 6.3\text{ V}$, $I_O = 5\text{ to }500\text{ mA}$		5	25	mV
I_d	Quiescent current	$V_I = 6\text{ to }16\text{ V}$, $I_O = 0\text{ mA}$	ON mode	0.5	1	mA
		$V_I = 6.3\text{ to }16\text{ V}$, $I_O = 500\text{ mA}$			12	
		$V_I = 6\text{ V}$	OFF mode	50	100	μA
SVR	Supply voltage rejection	$I_O = 5\text{ mA}$, $V_I = 7 \pm 1\text{ V}$	$f = 120\text{ Hz}$		76	dB
			$f = 1\text{ kHz}$		71	
			$f = 10\text{ kHz}$		60	
eN	Output noise voltage	$B = 10\text{ Hz to }100\text{ kHz}$		50		μV
V_d	Dropout voltage	$I_O = 200\text{ mA}$		0.2	0.35	V
		$I_O = 500\text{ mA}$		0.4	0.7	
V_{IL}	Control input logic low	$T_a = -40\text{ to }125\text{ °C}$			0.8	V
V_{IH}	Control input logic high	$T_a = -40\text{ to }125\text{ °C}$	2			V
I_I	Control input current	$V_I = 6\text{ V}$, $V_C = 6\text{ V}$		10		μA
C_O	Output bypass capacitance	$\text{ESR} = 0.1\text{ to }10\text{ }\Omega$, $I_O = 0\text{ to }500\text{ mA}$	2	10		μF

Refer to test circuits, $T_a = -40$ to 125 °C, $C_1 = 0.1$ μ F, $C_O = 2.2$ μ F unless otherwise specified.

Table 15. LF50AB (automotive grade) electrical characteristics

Symbol	Parameter	Test conditions	Min.	Typ.	Max.	Unit
V_O	Output voltage	$I_O = 50$ mA, $V_I = 7$ V, $T_a = 25$ °C	4.95	5	5.05	V
		$I_O = 50$ mA, $V_I = 7$ V	4.885		5.115	
V_I	Operating input voltage	$I_O = 500$ mA			16	V
I_O	Output current limit	$T_a = 25$ °C		1		A
ΔV_O	Line regulation	$V_I = 6$ to 16 V, $I_O = 5$ mA		5	28	mV
ΔV_O	Load regulation	$V_I = 6.3$ V, $I_O = 5$ to 500 mA		5	28	mV
I_d	Quiescent current	$V_I = 6$ to 16 V, $I_O = 0$ mA	ON mode	0.5	2	mA
		$V_I = 6.3$ to 16 V, $I_O = 500$ mA			12	
		$V_I = 6$ V	OFF mode	50	120	μ A
SVR	Supply voltage rejection	$I_O = 5$ mA, $V_I = 7 \pm 1$ V $T_a = 25$ °C	f = 120 Hz		76	dB
			f = 1 kHz		71	
			f = 10 kHz		60	
eN	Output noise voltage	B = 10 Hz to 100 kHz, $T_a = 25$ °C		50		μ V
V_d	Dropout voltage	$I_O = 200$ mA		0.2	1.3	V
		$I_O = 500$ mA		0.4	1.3	
V_{IL}	Control input logic low				0.8	V
V_{IH}	Control input logic high		2			V
I_I	Control input current	$V_I = 6$ V, $V_C = 6$ V, $T_a = 25$ °C		10		μ A
C_O	Output bypass capacitance	ESR = 0.1 to 10 Ω , $I_O = 0$ to 500 mA	2	10		μ F

Refer to test circuits, $T_J = 25\text{ °C}$, $C_I = 0.1\text{ }\mu\text{F}$, $C_O = 2.2\text{ }\mu\text{F}$ unless otherwise specified.

Table 16. LF50C electrical characteristics

Symbol	Parameter	Test conditions	Min.	Typ.	Max.	Unit
V_O	Output voltage	$I_O = 50\text{ mA}$, $V_I = 7\text{ V}$	4.9	5	5.1	V
		$I_O = 50\text{ mA}$, $V_I = 7\text{ V}$, $T_a = -25\text{ to }85\text{ °C}$	4.8		5.2	
V_I	Operating input voltage	$I_O = 500\text{ mA}$			16	V
I_O	Output current limit			1		A
ΔV_O	Line regulation	$V_I = 6\text{ to }16\text{ V}$, $I_O = 5\text{ mA}$		5	25	mV
ΔV_O	Load regulation	$V_I = 6.3\text{ V}$, $I_O = 5\text{ to }500\text{ mA}$		5	25	mV
I_d	Quiescent current	$V_I = 6\text{ to }16\text{ V}$, $I_O = 0\text{ mA}$	ON mode	0.5	1	mA
		$V_I = 6.3\text{ to }16\text{ V}$, $I_O = 500\text{ mA}$			12	
		$V_I = 6\text{ V}$	OFF mode	50	100	μA
SVR	Supply voltage rejection	$I_O = 5\text{ mA}$, $V_I = 7 \pm 1\text{ V}$	$f = 120\text{ Hz}$		76	dB
			$f = 1\text{ kHz}$		71	
			$f = 10\text{ kHz}$		60	
eN	Output noise voltage	$B = 10\text{ Hz to }100\text{ kHz}$		50		μV
V_d	Dropout voltage	$I_O = 200\text{ mA}$		0.2	0.35	V
		$I_O = 500\text{ mA}$		0.4	0.7	
V_{IL}	Control input logic low	$T_a = -40\text{ to }125\text{ °C}$			0.8	V
V_{IH}	Control input logic high	$T_a = -40\text{ to }125\text{ °C}$	2			V
I_I	Control input current	$V_I = 6\text{ V}$, $V_C = 6\text{ V}$		10		μA
C_O	Output bypass capacitance	$\text{ESR} = 0.1\text{ to }10\text{ }\Omega$, $I_O = 0\text{ to }500\text{ mA}$	2	10		μF

Refer to test circuits, $T_a = -40$ to 125 °C, $C_I = 0.1$ μ F, $C_O = 2.2$ μ F unless otherwise specified.

Table 17. LF50C (automotive grade) electrical characteristics

Symbol	Parameter	Test conditions	Min.	Typ.	Max.	Unit
V_O	Output voltage	$I_O = 50$ mA, $V_I = 7$ V, $T_a = 25$ °C	4.9	5	5.1	V
		$I_O = 50$ mA, $V_I = 7$ V	4.785		5.215	
V_I	Operating input voltage	$I_O = 500$ mA			16	V
I_O	Output current limit	$T_a = 25$ °C		1		A
ΔV_O	Line regulation	$V_I = 6$ to 16 V, $I_O = 5$ mA		5	28	mV
ΔV_O	Load regulation	$V_I = 6.3$ V, $I_O = 5$ to 500 mA		5	28	mV
I_d	Quiescent current	$V_I = 6$ to 16 V, $I_O = 0$ mA	ON mode	0.5	2	mA
		$V_I = 6.3$ to 16 V, $I_O = 500$ mA			12	
		$V_I = 6$ V	OFF mode	50	120	μ A
SVR	Supply voltage rejection	$I_O = 5$ mA, $V_I = 7 \pm 1$ V $T_a = 25$ °C	f = 120 Hz		76	dB
			f = 1 kHz		71	
			f = 10 kHz		60	
eN	Output noise voltage	B = 10 Hz to 100 kHz, $T_a = 25$ °C		50		μ V
V_d	Dropout voltage	$I_O = 200$ mA		0.2	1.3	V
		$I_O = 500$ mA		0.4	1.3	
V_{IL}	Control input logic low				0.8	V
V_{IH}	Control input logic high		2			V
I_I	Control input current	$V_I = 6$ V, $V_C = 6$ V, $T_a = 25$ °C		10		μ A
C_O	Output bypass capacitance	ESR = 0.1 to 10 Ω , $I_O = 0$ to 500 mA	2	10		μ F

Refer to test circuits, $T_J = 25\text{ °C}$, $C_I = 0.1\text{ }\mu\text{F}$, $C_O = 2.2\text{ }\mu\text{F}$ unless otherwise specified.

Table 18. LF60AB electrical characteristics

Symbol	Parameter	Test conditions	Min.	Typ.	Max.	Unit
V_O	Output voltage	$I_O = 50\text{ mA}$, $V_I = 8\text{ V}$	5.94	6	6.06	V
		$I_O = 50\text{ mA}$, $V_I = 8\text{ V}$, $T_a = -25\text{ to }85\text{ °C}$	5.88		6.12	
V_I	Operating input voltage	$I_O = 500\text{ mA}$			16	V
I_O	Output current limit			1		A
ΔV_O	Line regulation	$V_I = 7\text{ to }16\text{ V}$, $I_O = 5\text{ mA}$		6	30	mV
ΔV_O	Load regulation	$V_I = 7.3\text{ V}$, $I_O = 5\text{ to }500\text{ mA}$		6	30	mV
I_d	Quiescent current	$V_I = 7\text{ to }16\text{ V}$, $I_O = 0\text{ mA}$	ON mode	0.7	1.5	mA
		$V_I = 7.3\text{ to }16\text{ V}$, $I_O = 500\text{ mA}$			12	
		$V_I = 9\text{ V}$	OFF mode	70	140	μA
SVR	Supply voltage rejection	$I_O = 5\text{ mA}$, $V_I = 8 \pm 1\text{ V}$	$f = 120\text{ Hz}$		75	dB
			$f = 1\text{ kHz}$		70	
			$f = 10\text{ kHz}$		60	
eN	Output noise voltage	$B = 10\text{ Hz to }100\text{ kHz}$		50		μV
V_d	Dropout voltage	$I_O = 200\text{ mA}$		0.2	0.35	V
		$I_O = 500\text{ mA}$		0.4	0.7	
V_{IL}	Control input logic low	$T_a = -40\text{ to }125\text{ °C}$			0.8	V
V_{IH}	Control input logic high	$T_a = -40\text{ to }125\text{ °C}$	2			V
I_I	Control input current	$V_I = 9\text{ V}$, $V_C = 6\text{ V}$		10		μA
C_O	Output bypass capacitance	$\text{ESR} = 0.1\text{ to }10\text{ }\Omega$, $I_O = 0\text{ to }500\text{ mA}$	2	10		μF

Refer to test circuits, $T_J = 25\text{ °C}$, $C_I = 0.1\text{ }\mu\text{F}$, $C_O = 2.2\text{ }\mu\text{F}$ unless otherwise specified.

Table 19. LF60C electrical characteristics

Symbol	Parameter	Test conditions	Min.	Typ.	Max.	Unit
V_O	Output voltage	$I_O = 50\text{ mA}$, $V_I = 8\text{ V}$	5.88	6	6.12	V
		$I_O = 50\text{ mA}$, $V_I = 8\text{ V}$, $T_a = -25\text{ to }85\text{ °C}$	5.76		6.24	
V_I	Operating input voltage	$I_O = 500\text{ mA}$			16	V
I_O	Output current limit			1		A
ΔV_O	Line regulation	$V_I = 7\text{ to }16\text{ V}$, $I_O = 5\text{ mA}$		6	30	mV
ΔV_O	Load regulation	$V_I = 7.3\text{ V}$, $I_O = 5\text{ to }500\text{ mA}$		6	30	mV
I_d	Quiescent current	$V_I = 7\text{ to }16\text{ V}$, $I_O = 0\text{ mA}$	ON mode	0.7	1.5	mA
		$V_I = 7.3\text{ to }16\text{ V}$, $I_O = 500\text{ mA}$			12	
		$V_I = 9\text{ V}$	OFF mode	70	140	μA
SVR	Supply voltage rejection	$I_O = 5\text{ mA}$, $V_I = 8 \pm 1\text{ V}$	f = 120 Hz		75	dB
			f = 1 kHz		70	
			f = 10 kHz		60	
eN	Output noise voltage	B = 10 Hz to 100 kHz		50		μV
V_d	Dropout voltage	$I_O = 200\text{ mA}$		0.2	0.35	V
		$I_O = 500\text{ mA}$		0.4	0.7	
V_{IL}	Control input logic low	$T_a = -40\text{ to }125\text{ °C}$			0.8	V
V_{IH}	Control input logic high	$T_a = -40\text{ to }125\text{ °C}$	2			V
I_I	Control input current	$V_I = 9\text{ V}$, $V_C = 6\text{ V}$		10		μA
C_O	Output bypass capacitance	ESR = 0.1 to 10 Ω , $I_O = 0\text{ to }500\text{ mA}$	2	10		μF

Refer to test circuits, $T_J = 25\text{ °C}$, $C_I = 0.1\text{ }\mu\text{F}$, $C_O = 2.2\text{ }\mu\text{F}$ unless otherwise specified.

Table 20. LF80AB electrical characteristics

Symbol	Parameter	Test conditions	Min.	Typ.	Max.	Unit
V_O	Output voltage	$I_O = 50\text{ mA}$, $V_I = 10\text{ V}$	7.92	8	8.08	V
		$I_O = 50\text{ mA}$, $V_I = 10\text{ V}$, $T_a = -25\text{ to }85\text{ °C}$	7.84		8.16	
V_I	Operating input voltage	$I_O = 500\text{ mA}$			16	V
I_O	Output current limit			1		A
ΔV_O	Line regulation	$V_I = 9\text{ to }16\text{ V}$, $I_O = 5\text{ mA}$		8	40	mV
ΔV_O	Load regulation	$V_I = 9.3\text{ V}$, $I_O = 5\text{ to }500\text{ mA}$		8	40	mV
I_d	Quiescent current	$V_I = 9\text{ to }16\text{ V}$, $I_O = 0\text{ mA}$	ON mode	0.7	1.5	mA
		$V_I = 9.3\text{ to }16\text{ V}$, $I_O = 500\text{ mA}$			12	
		$V_I = 9\text{ V}$	OFF mode	70	140	μA
SVR	Supply voltage rejection	$I_O = 5\text{ mA}$, $V_I = 10 \pm 1\text{ V}$	$f = 120\text{ Hz}$		72	dB
			$f = 1\text{ kHz}$		67	
			$f = 10\text{ kHz}$		57	
eN	Output noise voltage	$B = 10\text{ Hz to }100\text{ kHz}$		50		μV
V_d	Dropout voltage	$I_O = 200\text{ mA}$		0.2	0.35	V
		$I_O = 500\text{ mA}$		0.4	0.7	
V_{IL}	Control input logic low	$T_a = -40\text{ to }125\text{ °C}$			0.8	V
V_{IH}	Control input logic high	$T_a = -40\text{ to }125\text{ °C}$	2			V
I_I	Control input current	$V_I = 9\text{ V}$, $V_C = 6\text{ V}$		10		μA
C_O	Output bypass capacitance	$\text{ESR} = 0.1\text{ to }10\text{ }\Omega$, $I_O = 0\text{ to }500\text{ mA}$	2	10		μF

Refer to test circuits, $T_J = 25\text{ °C}$, $C_I = 0.1\text{ }\mu\text{F}$, $C_O = 2.2\text{ }\mu\text{F}$ unless otherwise specified.

Table 21. LF80C electrical characteristics

Symbol	Parameter	Test conditions	Min.	Typ.	Max.	Unit
V_O	Output voltage	$I_O = 50\text{ mA}$, $V_I = 10\text{ V}$	7.84	8	8.16	V
		$I_O = 50\text{ mA}$, $V_I = 10\text{ V}$, $T_a = -25\text{ to }85\text{ °C}$	7.68		8.32	
V_I	Operating input voltage	$I_O = 500\text{ mA}$			16	V
I_O	Output current limit			1		A
ΔV_O	Line regulation	$V_I = 9\text{ to }16\text{ V}$, $I_O = 5\text{ mA}$		8	40	mV
ΔV_O	Load regulation	$V_I = 9.3\text{ V}$, $I_O = 5\text{ to }500\text{ mA}$		8	40	mV
I_d	Quiescent current	$V_I = 9\text{ to }16\text{ V}$, $I_O = 0\text{ mA}$	ON mode	0.7	1.5	mA
		$V_I = 9.3\text{ to }16\text{ V}$, $I_O = 500\text{ mA}$			12	
		$V_I = 9\text{ V}$	OFF mode	70	140	μA
SVR	Supply voltage rejection	$I_O = 5\text{ mA}$, $V_I = 10 \pm 1\text{ V}$	f = 120 Hz		72	dB
			f = 1 kHz		67	
			f = 10 kHz		57	
eN	Output noise voltage	B = 10 Hz to 100 kHz		50		μV
V_d	Dropout voltage	$I_O = 200\text{ mA}$		0.2	0.35	V
		$I_O = 500\text{ mA}$		0.4	0.7	
V_{IL}	Control input logic low	$T_a = -40\text{ to }125\text{ °C}$			0.8	V
V_{IH}	Control input logic high	$T_a = -40\text{ to }125\text{ °C}$	2			V
I_I	Control input current	$V_I = 9\text{ V}$, $V_C = 6\text{ V}$		10		μA
C_O	Output bypass capacitance	ESR = 0.1 to 10 Ω , $I_O = 0\text{ to }500\text{ mA}$	2	10		μF

Refer to test circuits, $T_a = -40$ to 125 °C, $C_1 = 0.1$ μ F, $C_O = 2.2$ μ F unless otherwise specified.

Table 22. LF80C (automotive grade) electrical characteristics

Symbol	Parameter	Test conditions	Min.	Typ.	Max.	Unit
V_O	Output voltage	$I_O = 50$ mA, $V_I = 10$ V, $T_a = 25$ °C	7.84	8	8.16	V
		$I_O = 50$ mA, $V_I = 10$ V	7.665		8.335	
V_I	Operating input voltage	$I_O = 500$ mA			16	V
I_O	Output current limit	$T_a = 25$ °C		1		A
ΔV_O	Line regulation	$V_I = 9$ to 16 V, $I_O = 5$ mA		8	44	mV
ΔV_O	Load regulation	$V_I = 9.3$ V, $I_O = 5$ to 500 mA		8	44	mV
I_d	Quiescent current	$V_I = 9$ to 16 V, $I_O = 0$ mA	ON mode	0.7	2.5	mA
		$V_I = 9.3$ to 16 V, $I_O = 500$ mA				
		$V_I = 9$ V	OFF mode	70	160	
SVR	Supply voltage rejection	$I_O = 5$ mA, $V_I = 10 \pm 1$ V $T_a = 25$ °C	$f = 120$ Hz		72	dB
			$f = 1$ kHz		67	
			$f = 10$ kHz		57	
eN	Output noise voltage	$B = 10$ Hz to 100 kHz, $T_a = 25$ °C		50		μ V
V_d	Dropout voltage	$I_O = 200$ mA		0.2	1.3	V
		$I_O = 500$ mA		0.4	1.3	
V_{IL}	Control input logic low				0.8	V
V_{IH}	Control input logic high		2			V
I_I	Control input current	$V_I = 9$ V, $V_C = 6$ V, $T_a = 25$ °C		10		μ A
C_O	Output bypass capacitance	ESR = 0.1 to 10 Ω , $I_O = 0$ to 500 mA	2	10		μ F

Refer to test circuits, $T_J = 25\text{ °C}$, $C_I = 0.1\text{ }\mu\text{F}$, $C_O = 2.2\text{ }\mu\text{F}$ unless otherwise specified.

Table 23. LF85AB electrical characteristics

Symbol	Parameter	Test conditions	Min.	Typ.	Max.	Unit
V_O	Output voltage	$I_O = 50\text{ mA}$, $V_I = 10.5\text{ V}$	8.415	8.5	8.585	V
		$I_O = 50\text{ mA}$, $V_I = 10.5\text{ V}$, $T_a = -25\text{ to }85\text{ °C}$	8.33		8.67	
V_I	Operating input voltage	$I_O = 500\text{ mA}$			16	V
I_O	Output current limit			1		A
ΔV_O	Line regulation	$V_I = 9.5\text{ to }16\text{ V}$, $I_O = 5\text{ mA}$		8	42	mV
ΔV_O	Load regulation	$V_I = 9.8\text{ V}$, $I_O = 5\text{ to }500\text{ mA}$		8	42	mV
I_d	Quiescent current	$V_I = 9.5\text{ to }16\text{ V}$, $I_O = 0\text{ mA}$	ON mode	0.7	1.5	mA
		$V_I = 9.8\text{ to }16\text{ V}$, $I_O = 500\text{ mA}$			12	
		$V_I = 9\text{ V}$	OFF mode	70	140	μA
SVR	Supply voltage rejection	$I_O = 5\text{ mA}$, $V_I = 10.5 \pm 1\text{ V}$	f = 120 Hz		72	dB
			f = 1 kHz		67	
			f = 10 kHz		57	
eN	Output noise voltage	B = 10 Hz to 100 kHz		50		μV
V_d	Dropout voltage	$I_O = 200\text{ mA}$		0.2	0.35	V
		$I_O = 500\text{ mA}$		0.4	0.7	
V_{IL}	Control input logic low	$T_a = -40\text{ to }125\text{ °C}$			0.8	V
V_{IH}	Control input logic high	$T_a = -40\text{ to }125\text{ °C}$	2			V
I_I	Control input current	$V_I = 9\text{ V}$, $V_C = 6\text{ V}$		10		μA
C_O	Output bypass capacitance	ESR = 0.1 to 10 Ω , $I_O = 0\text{ to }500\text{ mA}$	2	10		μF

Refer to test circuits, $T_J = 25\text{ °C}$, $C_I = 0.1\text{ }\mu\text{F}$, $C_O = 2.2\text{ }\mu\text{F}$ unless otherwise specified.

Table 24. LF85C electrical characteristics

Symbol	Parameter	Test conditions	Min.	Typ.	Max.	Unit
V_O	Output voltage	$I_O = 50\text{ mA}$, $V_I = 10.5\text{ V}$	8.33	8.5	8.67	V
		$I_O = 50\text{ mA}$, $V_I = 10.5\text{ V}$, $T_a = -25\text{ to }85\text{ °C}$	8.16		8.84	
V_I	Operating input voltage	$I_O = 500\text{ mA}$			16	V
I_O	Output current limit			1		A
ΔV_O	Line regulation	$V_I = 9.5\text{ to }16\text{ V}$, $I_O = 5\text{ mA}$		8	42	mV
ΔV_O	Load regulation	$V_I = 9.8\text{ V}$, $I_O = 5\text{ to }500\text{ mA}$		8	42	mV
I_d	Quiescent current	$V_I = 9.5\text{ to }16\text{ V}$, $I_O = 0\text{ mA}$	ON mode	0.7	1.5	mA
		$V_I = 9.8\text{ to }16\text{ V}$, $I_O = 500\text{ mA}$			12	
		$V_I = 9\text{ V}$	OFF mode	70	140	μA
SVR	Supply voltage rejection	$I_O = 5\text{ mA}$, $V_I = 10.5 \pm 1\text{ V}$	$f = 120\text{ Hz}$		72	dB
			$f = 1\text{ kHz}$		67	
			$f = 10\text{ kHz}$		57	
eN	Output noise voltage	$B = 10\text{ Hz to }100\text{ kHz}$		50		μV
V_d	Dropout voltage	$I_O = 200\text{ mA}$		0.2	0.35	V
		$I_O = 500\text{ mA}$		0.4	0.7	
V_{IL}	Control input logic low	$T_a = -40\text{ to }125\text{ °C}$			0.8	V
V_{IH}	Control input logic high	$T_a = -40\text{ to }125\text{ °C}$	2			V
I_I	Control input current	$V_I = 9\text{ V}$, $V_C = 6\text{ V}$		10		μA
C_O	Output bypass capacitance	$\text{ESR} = 0.1\text{ to }10\text{ }\Omega$, $I_O = 0\text{ to }500\text{ mA}$	2	10		μF

Refer to test circuits, $T_a = -40$ to 125 °C, $C_I = 0.1$ μ F, $C_O = 2.2$ μ F unless otherwise specified.

Table 25. LF85C (automotive grade) electrical characteristics

Symbol	Parameter	Test conditions	Min.	Typ.	Max.	Unit	
V_O	Output voltage	$I_O = 50$ mA, $V_I = 10.5$ V, $T_a = 25$ °C	8.33	8.5	8.67	V	
		$I_O = 50$ mA, $V_I = 10.5$ V	8.145		8.855		
V_I	Operating input voltage	$I_O = 500$ mA			16	V	
I_O	Output current limit	$T_a = 25$ °C		1		A	
ΔV_O	Line regulation	$V_I = 9.5$ to 16 V, $I_O = 5$ mA		8	44	mV	
ΔV_O	Load regulation	$V_I = 9.8$ V, $I_O = 5$ to 500 mA		8	44	mV	
I_d	Quiescent current	$V_I = 9.5$ to 16 V, $I_O = 0$ mA	ON mode		0.7	2.5	mA
		$V_I = 9.8$ to 16 V, $I_O = 500$ mA			12		
		$V_I = 9$ V	OFF mode		70	160	μ A
SVR	Supply voltage rejection	$I_O = 5$ mA, $V_I = 10.5 \pm 1$ V $T_a = 25$ °C	f = 120 Hz		72	dB	
			f = 1 kHz		67		
			f = 10 kHz		57		
eN	Output noise voltage	B = 10 Hz to 100 kHz, $T_a = 25$ °C		50		μ V	
V_d	Dropout voltage	$I_O = 200$ mA		0.2	1.3	V	
		$I_O = 500$ mA		0.4	1.3		
V_{IL}	Control input logic low				0.8	V	
V_{IH}	Control input logic high		2			V	
I_I	Control input current	$V_I = 9$ V, $V_C = 6$ V, $T_a = 25$ °C		10		μ A	
C_O	Output bypass capacitance	ESR = 0.1 to 10 Ω , $I_O = 0$ to 500 mA	2	10		μ F	

Refer to test circuits, $T_J = 25\text{ }^\circ\text{C}$, $C_I = 0.1\text{ }\mu\text{F}$, $C_O = 2.2\text{ }\mu\text{F}$ unless otherwise specified.

Table 26. LF90C electrical characteristics

Symbol	Parameter	Test conditions	Min.	Typ.	Max.	Unit
V_O	Output voltage	$I_O = 50\text{ mA}$, $V_I = 11\text{ V}$	8.82	9	9.18	V
		$I_O = 50\text{ mA}$, $V_I = 11\text{ V}$, $T_a = -25\text{ to }85\text{ }^\circ\text{C}$	8.64		9.36	
V_I	Operating input voltage	$I_O = 500\text{ mA}$			16	V
I_O	Output current limit			1		A
ΔV_O	Line regulation	$V_I = 10\text{ to }16\text{ V}$, $I_O = 5\text{ mA}$		9	45	mV
ΔV_O	Load regulation	$V_I = 10.3\text{ V}$, $I_O = 5\text{ to }500\text{ mA}$		9	45	mV
I_d	Quiescent current	$V_I = 10\text{ to }16\text{ V}$, $I_O = 0\text{ mA}$	ON mode	0.7	1.5	mA
		$V_I = 10.3\text{ to }16\text{ V}$, $I_O = 500\text{ mA}$			12	
		$V_I = 10\text{ V}$	OFF mode	70	140	μA
SVR	Supply voltage rejection	$I_O = 5\text{ mA}$, $V_I = 11 \pm 1\text{ V}$	$f = 120\text{ Hz}$		71	dB
			$f = 1\text{ kHz}$		66	
			$f = 10\text{ kHz}$		56	
eN	Output noise voltage	$B = 10\text{ Hz to }100\text{ kHz}$		50		μV
V_d	Dropout voltage	$I_O = 200\text{ mA}$		0.2	0.35	V
		$I_O = 500\text{ mA}$		0.4	0.7	
V_{IL}	Control input logic low	$T_a = -40\text{ to }125\text{ }^\circ\text{C}$			0.8	V
V_{IH}	Control input logic high	$T_a = -40\text{ to }125\text{ }^\circ\text{C}$	2			V
I_I	Control input current	$V_I = 10\text{ V}$, $V_C = 6\text{ V}$		10		μA
C_O	Output bypass capacitance	$\text{ESR} = 0.1\text{ to }10\text{ }\Omega$, $I_O = 0\text{ to }500\text{ mA}$	2	10		μF

Refer to test circuits, $T_J = 25\text{ °C}$, $C_I = 0.1\text{ }\mu\text{F}$, $C_O = 2.2\text{ }\mu\text{F}$ unless otherwise specified.

Table 27. LF120AB electrical characteristics

Symbol	Parameter	Test conditions	Min.	Typ.	Max.	Unit
V_O	Output voltage	$I_O = 50\text{ mA}$, $V_I = 15\text{ V}$	11.88	12	12.12	V
		$I_O = 50\text{ mA}$, $V_I = 15\text{ V}$, $T_a = -25\text{ to }85\text{ °C}$	11.76		12.24	
V_I	Operating input voltage	$I_O = 500\text{ mA}$			16	V
I_O	Output current limit			1		A
ΔV_O	Line regulation	$V_I = 13\text{ to }16\text{ V}$, $I_O = 5\text{ mA}$		12	60	mV
ΔV_O	Load regulation	$V_I = 13.3\text{ V}$, $I_O = 5\text{ to }500\text{ mA}$		12	60	mV
I_d	Quiescent current	$V_I = 13\text{ to }16\text{ V}$, $I_O = 0\text{ mA}$	ON mode	0.7	1.5	mA
		$V_I = 13.3\text{ to }16\text{ V}$, $I_O = 500\text{ mA}$			12	
		$V_I = 13\text{ V}$	OFF mode	70	140	μA
SVR	Supply voltage rejection	$I_O = 5\text{ mA}$, $V_I = 14 \pm 1\text{ V}$	f = 120 Hz		69	dB
			f = 1 kHz		64	
			f = 10 kHz		54	
eN	Output noise voltage	B = 10 Hz to 100 kHz		50		μV
V_d	Dropout voltage	$I_O = 200\text{ mA}$		0.2	0.35	V
		$I_O = 500\text{ mA}$		0.4	0.7	
V_{IL}	Control input logic low	$T_a = -40\text{ to }125\text{ °C}$			0.8	V
V_{IH}	Control input logic high	$T_a = -40\text{ to }125\text{ °C}$	2			V
I_I	Control input current	$V_I = 13\text{ V}$, $V_C = 6\text{ V}$		10		μA
C_O	Output bypass capacitance	ESR = 0.1 to 10 Ω , $I_O = 0\text{ to }500\text{ mA}$	2	10		μF

Refer to test circuits, $T_J = 25\text{ }^\circ\text{C}$, $C_I = 0.1\text{ }\mu\text{F}$, $C_O = 2.2\text{ }\mu\text{F}$ unless otherwise specified.

Table 28. LF120C electrical characteristics

Symbol	Parameter	Test conditions	Min.	Typ.	Max.	Unit
V_O	Output voltage	$I_O = 50\text{ mA}$, $V_I = 14\text{ V}$	11.76	12	12.24	V
		$I_O = 50\text{ mA}$, $V_I = 14\text{ V}$, $T_a = -25\text{ to }85\text{ }^\circ\text{C}$	11.52		12.48	
V_I	Operating input voltage	$I_O = 500\text{ mA}$			16	V
I_O	Output current limit			1		A
ΔV_O	Line regulation	$V_I = 13\text{ to }16\text{ V}$, $I_O = 5\text{ mA}$		12	60	mV
ΔV_O	Load regulation	$V_I = 13.3\text{ V}$, $I_O = 5\text{ to }500\text{ mA}$		12	60	mV
I_d	Quiescent current	$V_I = 13\text{ to }16\text{ V}$, $I_O = 0\text{ mA}$	ON mode	0.7	1.5	mA
		$V_I = 13.3\text{ to }16\text{ V}$, $I_O = 500\text{ mA}$			12	
		$V_I = 13\text{ V}$	OFF mode	70	140	μA
SVR	Supply voltage rejection	$I_O = 5\text{ mA}$, $V_I = 14 \pm 1\text{ V}$	$f = 120\text{ Hz}$		69	dB
			$f = 1\text{ kHz}$		64	
			$f = 10\text{ kHz}$		54	
eN	Output noise voltage	$B = 10\text{ Hz to }100\text{ kHz}$		50		μV
V_d	Dropout voltage	$I_O = 200\text{ mA}$		0.2	0.35	V
		$I_O = 500\text{ mA}$		0.4	0.7	
V_{IL}	Control input logic low	$T_a = -40\text{ to }125\text{ }^\circ\text{C}$			0.8	V
V_{IH}	Control input logic high	$T_a = -40\text{ to }125\text{ }^\circ\text{C}$	2			V
I_I	Control input current	$V_I = 13\text{ V}$, $V_C = 6\text{ V}$		10		μA
C_O	Output bypass capacitance	$\text{ESR} = 0.1\text{ to }10\text{ }\Omega$, $I_O = 0\text{ to }500\text{ mA}$	2	10		μF

5 Typical performance characteristics

Figure 4. Dropout voltage vs. output current

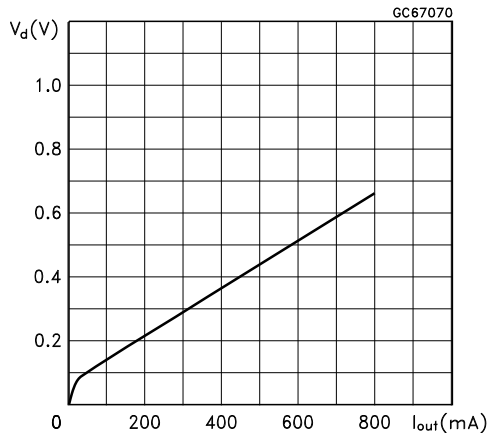

Figure 5. Dropout voltage vs. temperature

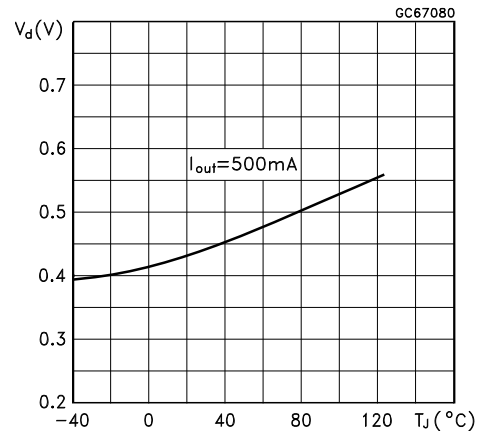

Figure 6. Supply current vs. input voltage

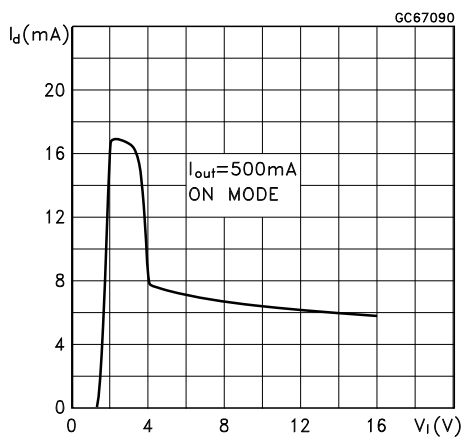

Figure 7. Supply current vs. input voltage (no load)

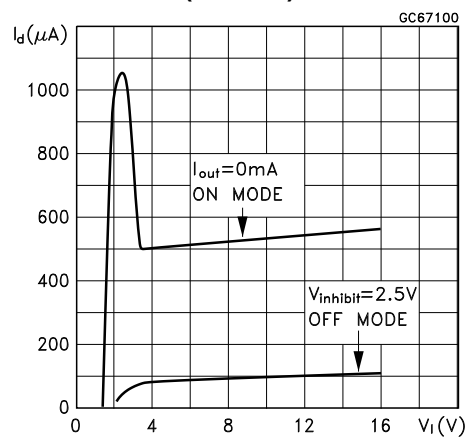

Figure 8. Short-circuit current vs. input voltage

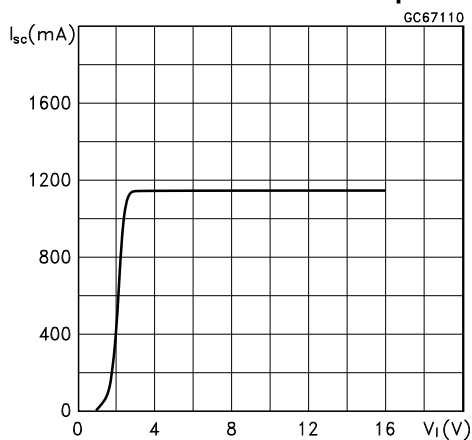
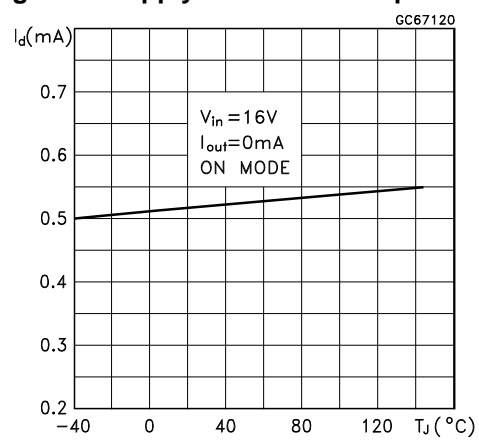

Figure 9. Supply current vs. temperature



Note: Unless otherwise specified $V_{O(NOM)} = 3.3$ V

Figure 12. Multiple supply with ON/OFF toggle switch

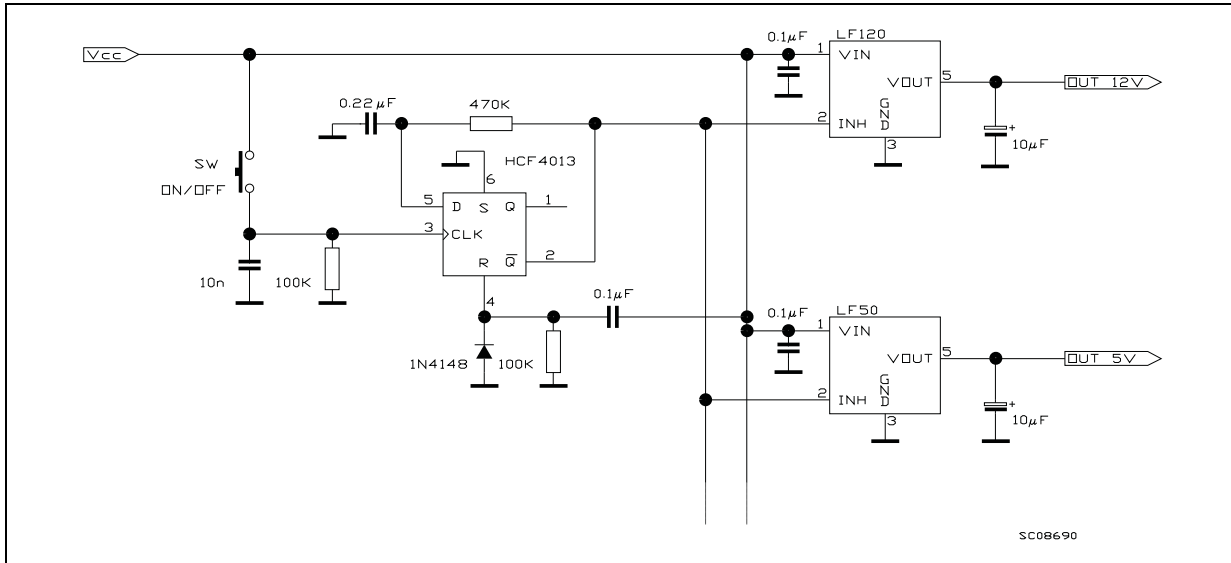

Figure 13. Basic inhibit functions

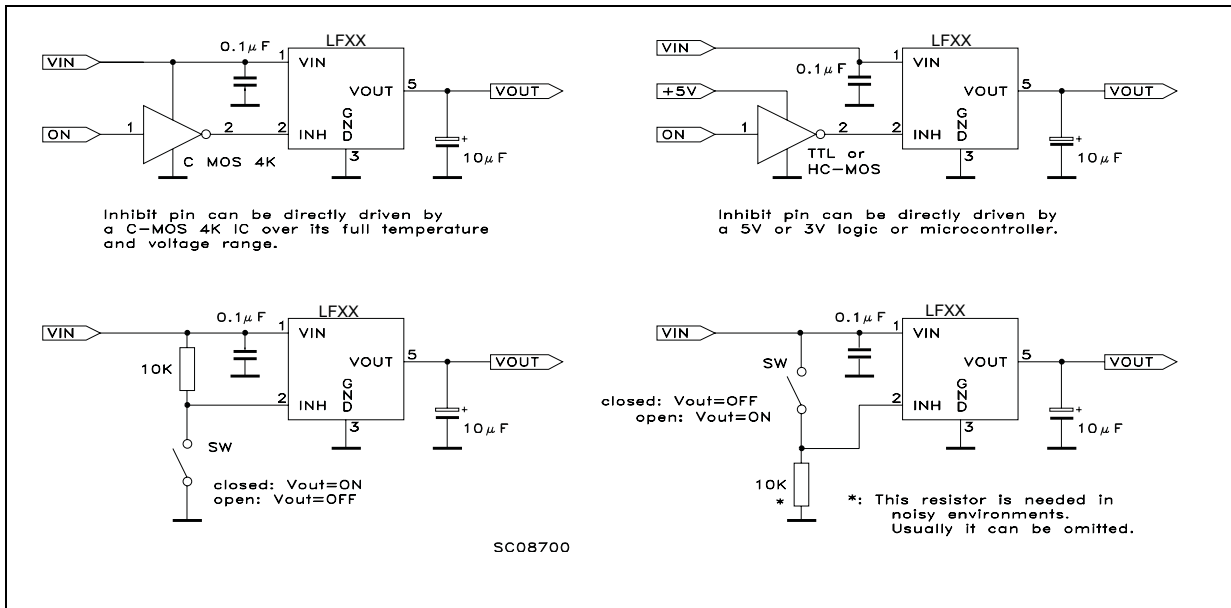

Figure 14. Delayed turn-on

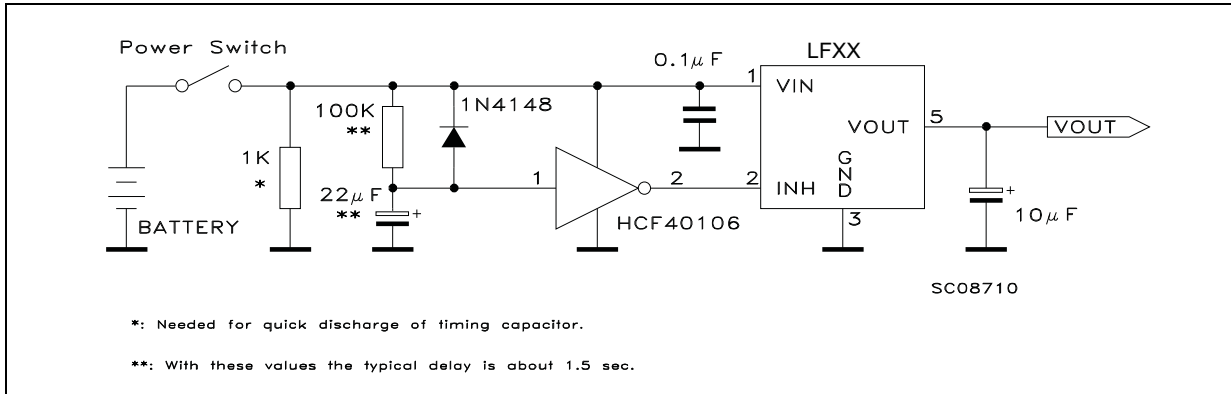
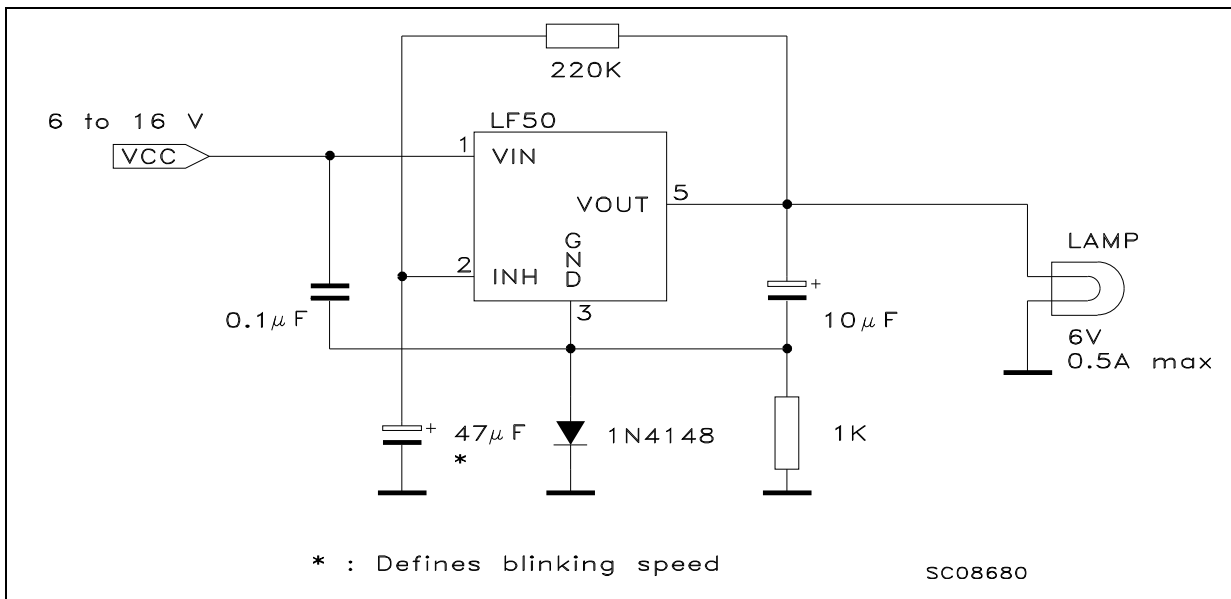

Figure 15. Low voltage bulb blinker



6 Package information

In order to meet environmental requirements, ST offers these devices in different grades of ECOPACK[®] packages, depending on their level of environmental compliance. ECOPACK[®] specifications, grade definitions and product status are available at: www.st.com. ECOPACK[®] is an ST trademark.

6.1 TO-220 package information

Figure 16. TO-220 (STD-ST dual gauge) package outline

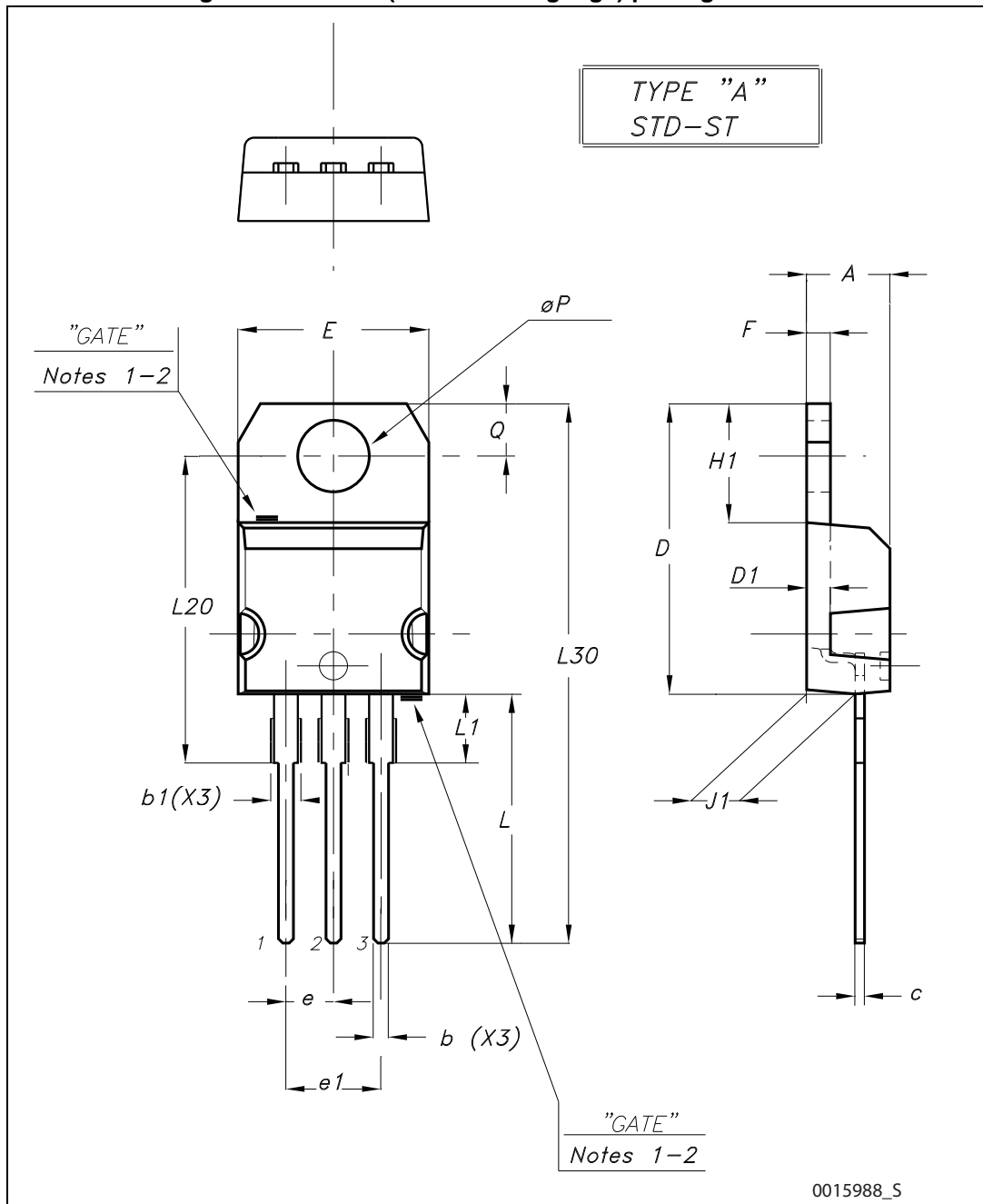

Figure 17. TO-220 (STD-ST single gauge) package outline

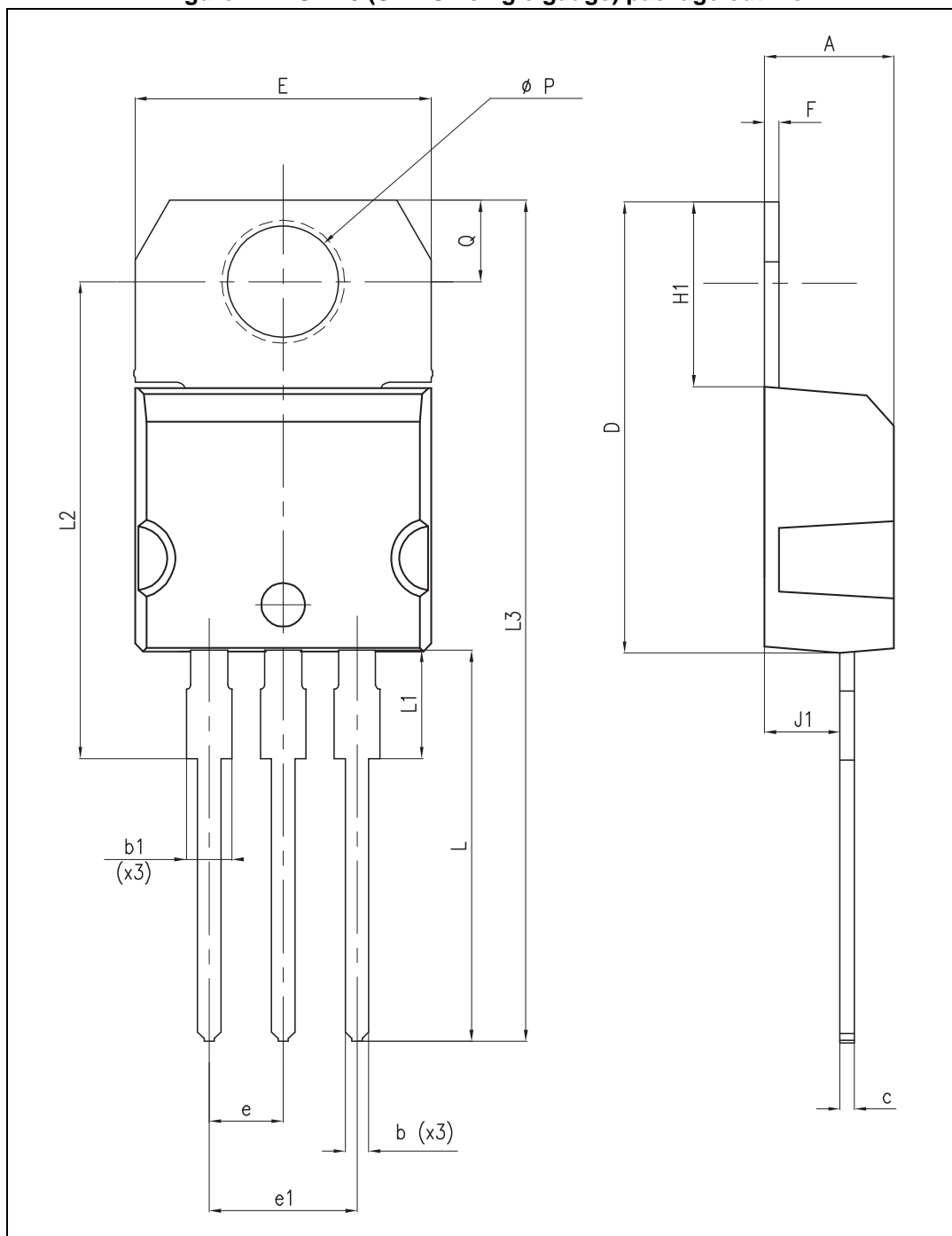
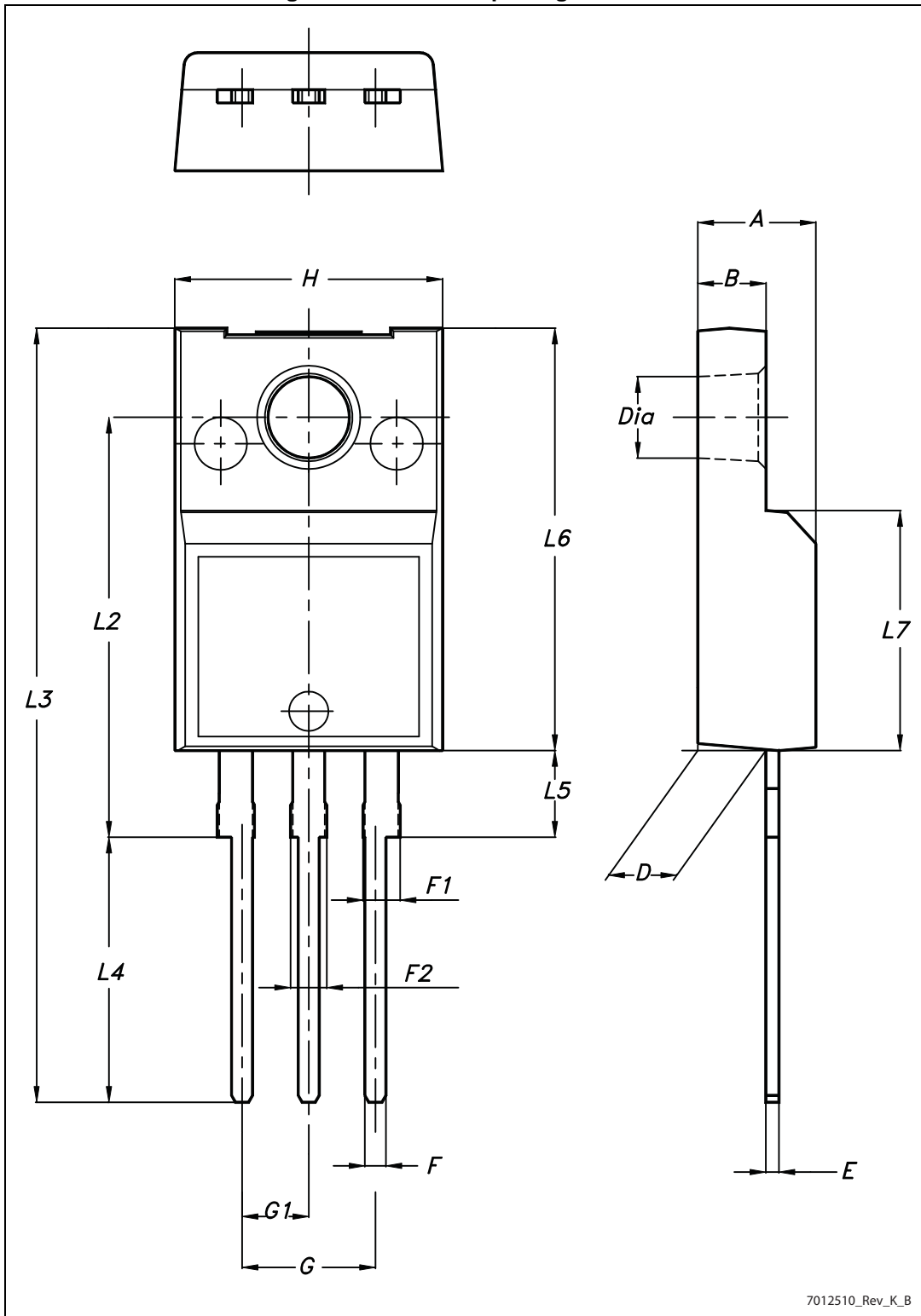

Table 29. TO-220 mechanical data

Dim.	Type STD - ST dual gauge			Type STD - ST single gauge		
	mm			mm		
	Min.	Typ.	Max.	Min.	Typ.	Max.
A	4.40		4.60	4.40		4.60
b	0.61		0.88	0.61		0.88
b1	1.14		1.70	1.14		1.70
c	0.48		0.70	0.48		0.70
D	15.25		15.75	15.25		15.75
D1		1.27				
E	10.00		10.40	10.00		10.40
e	2.40		2.70	2.40		2.70
e1	4.95		5.15	4.95		5.15
F	1.23		1.32	0.51		0.60
H1	6.20		6.60	6.20		6.60
J1	2.40		2.72	2.40		2.72
L	13.00		14.00	13.00		14.00
L1	3.50		3.93	3.50		3.93
L20		16.40			16.40	
L30		28.90			28.90	
∅P	3.75		3.85	3.75		3.85
Q	2.65		2.95	2.65		2.95

Note: Despite of some differences in tolerances, packages are compatible

Figure 18. TO-220FP package outline



7012510_Rev_K_B

Table 30. TO-220FP mechanical data

Dim.	mm		
	Min.	Typ.	Max.
A	4.4		4.6
B	2.5		2.7
D	2.5		2.75
E	0.45		0.7
F	0.75		1
F1	1.15		1.70
F2	1.15		1.70
G	4.95		5.2
G1	2.4		2.7
H	10		10.4
L2		16	
L3	28.6		30.6
L4	9.8		10.6
L5	2.9		3.6
L6	15.9		16.4
L7	9		9.3
Dia	3		3.2

6.3 DPAK package information

Figure 21. DPAK package outline

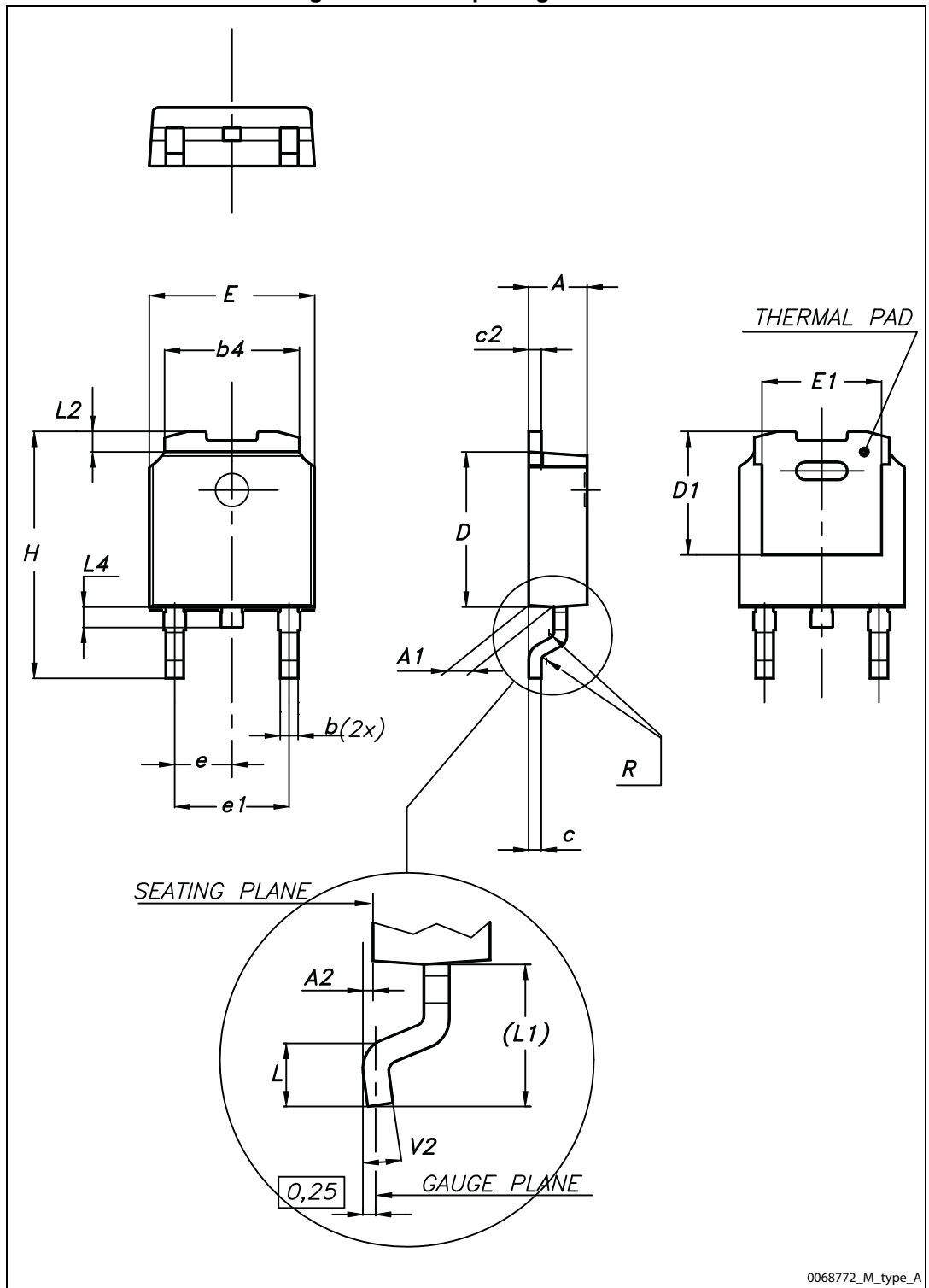
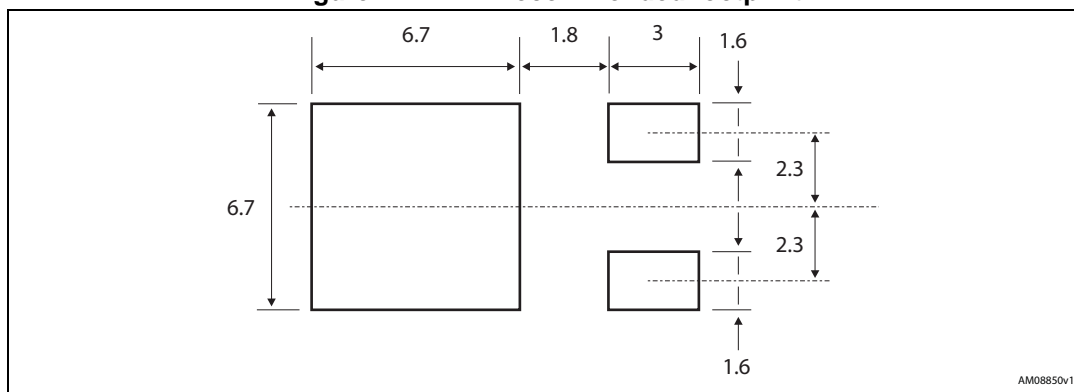

Table 31. DPAK mechanical data

Dim.	mm		
	Min.	Typ.	Max.
A	2.20		2.40
A1	0.90		1.10
A2	0.03		0.23
b	0.64		0.90
b4	5.20		5.40
c	0.45		0.60
c2	0.48		0.60
D	6.00		6.20
D1		5.10	
E	6.40		6.60
E1		4.70	
e		2.28	
e1	4.40		4.60
H	9.35		10.10
L	1.00		1.50
(L1)		2.80	
L2		0.80	
L4	0.60		1.00
R		0.20	
V2	0°		8°

Figure 22. DPAK recommended footprint



6.4 PPAK package information

Figure 23. PPAK package outline

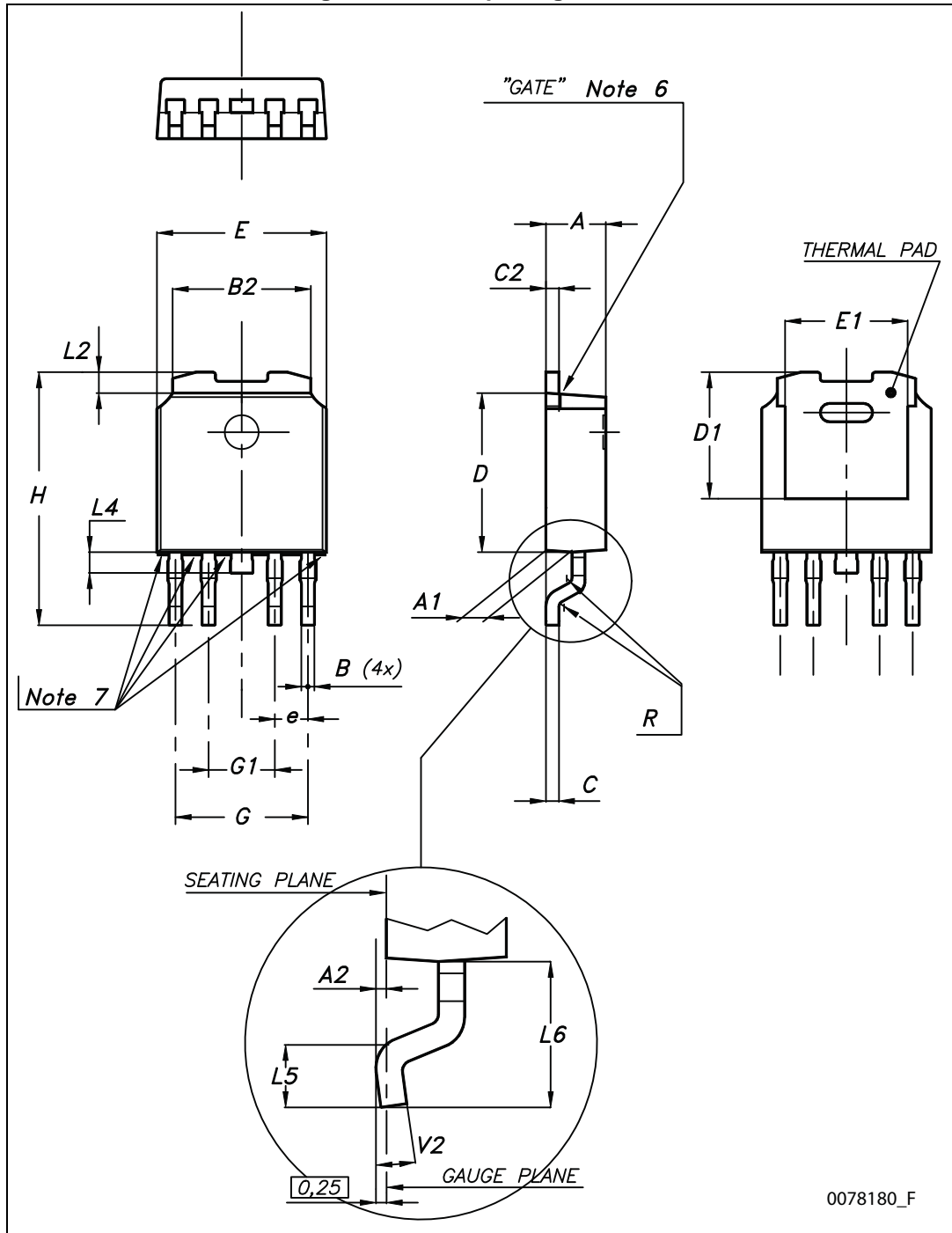

Table 32. PPAK mechanical data

Dim.	mm		
	Min.	Typ.	Max.
A	2.2		2.4
A1	0.9		1.1
A2	0.03		0.23
B	0.4		0.6
B2	5.2		5.4
C	0.45		0.6
C2	0.48		0.6
D	6		6.2
D1		5.1	
E	6.4		6.6
E1		4.7	
e		1.27	
G	4.9		5.25
G1	2.38		2.7
H	9.35		10.1
L2		0.8	1
L4	0.6		1
L5	1		
L6		2.8	
R		0.20	
V2	0°		8°

6.5 DPAK and PPAK packing information

Figure 24. DPAK and PPAK tape outline

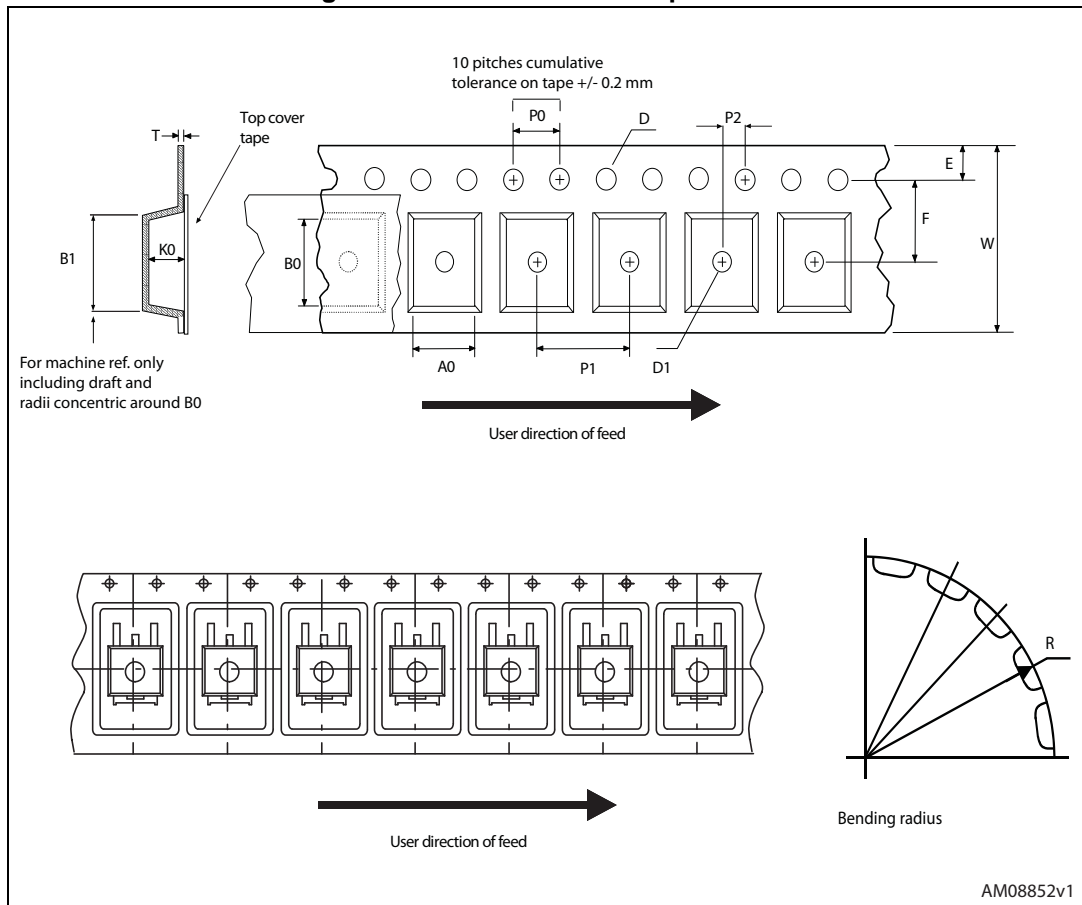

Figure 25. DPAK and PPAK reel outline

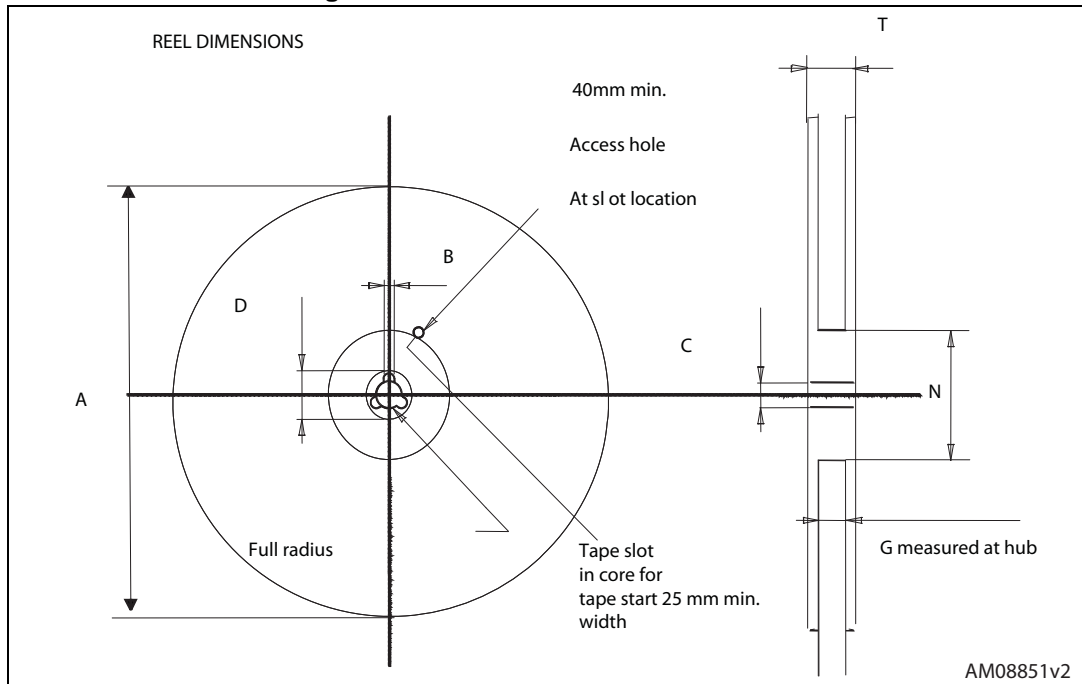

Table 33. DPAK and PPAK tape and reel mechanical data

Tape			Reel		
Dim.	mm		Dim.	mm	
	Min.	Max.		Min.	Max.
A0	6.8	7	A		330
B0	10.4	10.6	B	1.5	
B1		12.1	C	12.8	13.2
D	1.5	1.6	D	20.2	
D1	1.5		G	16.4	18.4
E	1.65	1.85	N	50	
F	7.4	7.6	T		22.4
K0	2.55	2.75			
P0	3.9	4.1	Base qty.		2500
P1	7.9	8.1	Bulk qty.		2500
P2	1.9	2.1			
R	40				
T	0.25	0.35			
W	15.7	16.3			

7 Ordering information

Table 34. Order code

Packages					Output voltages
TO-220	TO-220 (dual gauge)	TO-220FP	DPAK (tape and reel)	PPAK (tape and reel)	
			LF15ABDT-TR		1.5 V
			LF18CDT-TR	LF18CPT-TR	1.8 V
			LF18CDT-TRY ⁽¹⁾		1.8 V
			LF18ABDT-TR	LF18ABPT-TR	1.8 V
			LF25CDT-TR	LF25CPT-TR	2.5 V
			LF25CDT-TRY ⁽¹⁾		2.5 V
			LF25ABDT-TR		2.5 V
			LF25ABDT-TRY ⁽¹⁾		2.5 V
LF33CV	LF33CV-DG		LF33CDT-TR	LF33CPT-TR	3.3 V
			LF33CDT-TRY ⁽¹⁾	LF33CPT-TRY ⁽¹⁾	3.3 V
LF33ABV	LF33ABV-DG		LF33ABDT-TR		3.3 V
LF50CV	LF50CV-DG		LF50CDT-TR	LF50CPT-TR	5 V
			LF50CDT-TRY ⁽¹⁾	LF50CPT-TRY ⁽¹⁾	5 V
LF50ABV	LF50ABV-DG	LF50ABP	LF50ABDT-TR	LF50ABPT-TR	5 V
			LF50ABDT-TRY ⁽¹⁾		5 V
LF60CV			LF60CDT-TR		6 V
LF60ABV			LF60ABDT-TR		6 V
			LF80CDT-TR		8 V
			LF80CDT-TRY ⁽¹⁾		8 V
			LF80ABDT-TR		8 V
			LF85CDT-TR	LF85CPT-TR	8.5 V
			LF85CDT-TRY ⁽¹⁾	LF85CPT-TRY ⁽¹⁾	8.5 V
LF90CV				LF90CPT-TR	9 V
			LF120CDT-TR		12 V
LF120ABV			LF120ABDT-TR		12 V

1. Automotive grade products.

8 Revision history

Table 35. Document revision history

Date	Revision	Changes
21-Jun-2004	14	Document updating.
24-May-2006	15	Order codes updated.
02-Apr-2007	16	Order codes updated.
14-May-2007	17	Order codes updated.
26-Jul-2007	18	Add table 1 in cover page.
26-Nov-2007	19	Modified: Table 34 .
16-Jan-2008	20	Added new order codes for automotive grade products see Table 34 on page 51 .
12-Feb-2008	21	Modified: Table 34 on page 51 .
10-Jul-2008	22	Modified: Table 34 on page 51 .
05-May-2010	23	Added: Table 29 on page 41 , fig 16, fig 17, fig 18 and fig 19.
16-Nov-2010	24	Modified: R_{thJC} value for TO-220 Table 2 on page 7 .
10-Feb-2012	25	Added: order code LF33CV-DG and LF33ABV-DG Table 34 on page 51 .
09-Mar-2012	26	Added: order code LF50ABV-DG Table 34 on page 51 .
28-Feb-2014	27	<p>Changed the part numbers LFxxAB and LFxxC to LFXX.</p> <p>Changed the title.</p> <p>Removed table from cover page.</p> <p>Removed PENTAWATT package from the figure in cover page, the Description and Figure 2.</p> <p>Updated the Description.</p> <p>Updated: Table 2, Table 6, Table 8, Table 10, Table 13, Table 15, Table 17, Table 22, Table 25 and Table 34.</p> <p>Changed title of Figure 7.</p> <p>Updated mechanical data.</p>
03-Mar-2015	28	<p>Updated Table 34: Order code.</p> <p>Minor text changes.</p>

IMPORTANT NOTICE – PLEASE READ CAREFULLY

STMicroelectronics NV and its subsidiaries ("ST") reserve the right to make changes, corrections, enhancements, modifications, and improvements to ST products and/or to this document at any time without notice. Purchasers should obtain the latest relevant information on ST products before placing orders. ST products are sold pursuant to ST's terms and conditions of sale in place at the time of order acknowledgement.

Purchasers are solely responsible for the choice, selection, and use of ST products and ST assumes no liability for application assistance or the design of Purchasers' products.

No license, express or implied, to any intellectual property right is granted by ST herein.

Resale of ST products with provisions different from the information set forth herein shall void any warranty granted by ST for such product.

ST and the ST logo are trademarks of ST. All other product or service names are the property of their respective owners.

Information in this document supersedes and replaces information previously supplied in any prior versions of this document.

© 2015 STMicroelectronics – All rights reserved

Mouser Electronics

Authorized Distributor

Click to View Pricing, Inventory, Delivery & Lifecycle Information:

STMicroelectronics:

[LF25CDT](#) [LF80CV](#) [LF18ABPT](#) [LF18CPT](#) [LF25ABDT](#) [LF80ABDT](#) [LF60CDT](#) [LF120CPT](#) [LF90ABV](#) [LF18CDT](#)
[LF90CDT](#) [LF80CPT](#) [LF80ABV](#) [LF85ABPT-TR](#) [LF50CP](#) [LF85CP](#) [LF85ABPT](#) [LF15CDT](#) [LF90ABPT](#) [LF90CDT-TR](#)
[LF90ABPT-TR](#) [LF80CPT-TR](#) [LF90ABDT-TR](#) [LF27ABDT-TR](#) [LF27CDT](#) [LF27CDT-TR](#) [LF80ABPT-TR](#) [LF40CPT](#)
[LF90CPT](#) [LF30CV](#) [LF120CV](#) [LF60ABDT](#) [LF85CDT](#) [LF25ABV](#) [LF18ABV](#) [LF80ABPT](#) [LF25CPT](#) [LF120CDT](#)
[LF50ABPT](#) [LF50ABDT](#) [LF85CPT](#) [LF30CDT-TR](#) [LF30CPT](#) [LF33ABPT](#) [LF27ABDT](#) [LF33ABDT](#) [LF25CV](#)
[LF120ABDT](#) [LF33CPT](#) [LF33CDT](#) [LF27CPT](#) [LF35ABDT-TR](#) [LF30CDT](#) [LF30ABPT](#) [LF50CDT](#) [LF55CDT-TR](#)
[LF85ABP](#) [LF47CV](#) [LF35ABDT](#) [LF55CDT](#) [LF120CV5V](#) [LF35CDT](#) [LF33ABP](#) [LF90ABDT](#) [LF15ABDT](#) [LF52ABDT](#)
[LF80CDT](#)