

**FineAdjust  
Applicator**

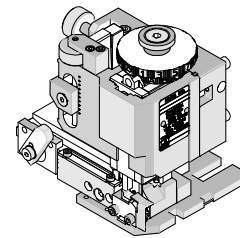

**Application Tooling  
Specification Sheet**



**Order No. 63863-2000**

**FEATURES**

- Directly adapts to most automatic wire processing machines
- Quick punch removal with the push of a button for fast and easy tooling change
- Applicator designed to industry standard mounting and shut height 135.80mm (5.346")
- Quick set-up time; plus the crimp height, track and feed adjustments can be set without removing the applicator from the press
- Fine adjustment allows users to achieve target with little effort by adjusting in increments of .015mm (.0006") for conductor crimp height and .063mm (.0025") for insulation height
- Independent adjustment rings allow users to quickly adjust the conductor or insulation crimp height without affecting each other

**SCOPE**

Products: Right Angle, 2.00mm (.079") Board-In Terminal for 24-30 AWG.

Terminal Series No.	Terminal Order No.		Wire Size		Insulation Diameter Maximum		Strip Length	
			AWG	mm <sup>2</sup>	mm	In.	mm	In.
35021	35021-1201	35021-1310	24-30	0.20-0.05	1.50	.059	1.80-2.20	.071-.087
	35021-1300	35021-1360						
	35021-1301							

**DEFINITION OF TERMS**

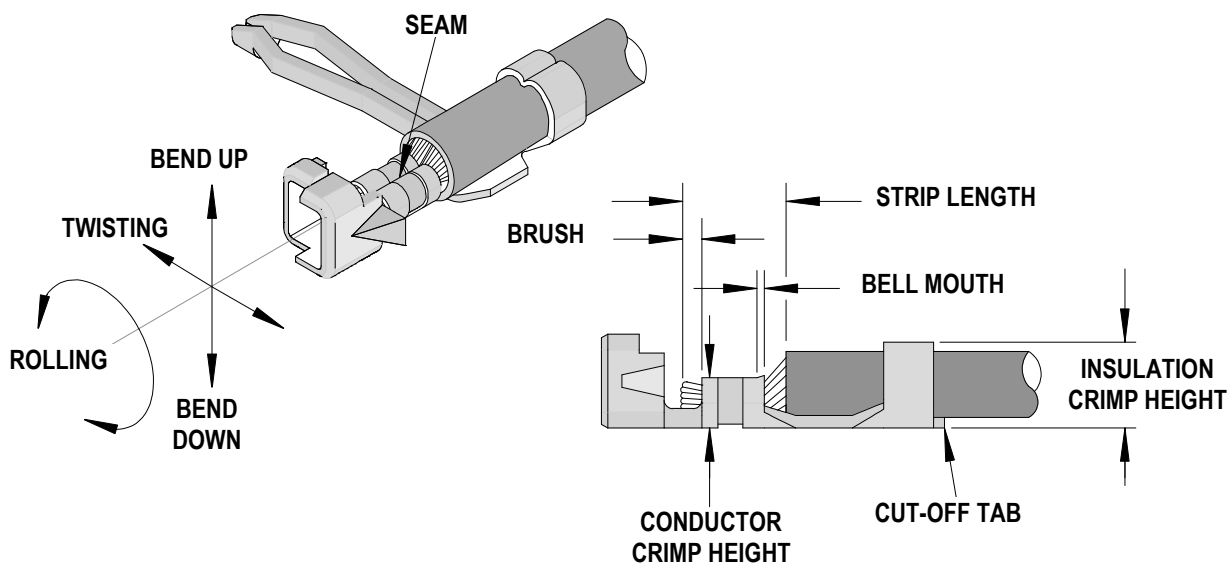

## CRIMP SPECIFICATION

Terminal Series No.	Bell mouth		Cut-off Tab Maximum		Conductor Brush	
	mm	In.	mm	In.	mm	In.
35021	0.20-0.50	.008-.020	0.30	.012	0.0-1.0	0.0-.039

Terminal Series No.	Bend up	Bend down	Twist	Roll	Punch Width mm (Ref)				Seam  Seam shall not be open and no wire allowed out of the crimping area
	Degree		Degree		Conductor		Insulation		
	mm	In	mm	In					
35021	3	3	3	3	1.20	.047	1.60	.063	

After crimping, the conductor profile should measure the following.

Terminal Series No.	Wire Size		Conductor			
			Crimp Height		Crimp Width (Ref)	
	AWG	mm2	mm	In.	mm	In.
35021	24	0.20	0.75-0.80	.030-.032	1.22	.048
	26	0.13	0.75-0.80	.030-.032	1.22	.048
	28	0.08	0.68-0.73	.027-.029	1.22	.048
	30	0.05	0.65-0.70	.026-.028	1.22	.048

Terminal Series No.	Wire Size		Insulation				Pull Force Minimum	
			Crimp Height (Ref)		Crimp Width (Ref)			
	AWG	mm2	mm	In.	mm	In.	N	Lb.
35021	24	0.20	1.50	.059	1.70	.067	29.4	6.60
	26	0.13	1.45	.057	1.70	.067	19.6	4.40
	28	0.08	1.40	.055	1.70	.067	9.8	2.20
	30	0.05	1.35	.053	1.70	.067	4.9	1.10

Tool Qualification Notes:

1. Pull Force should be measured with no influence from the insulation crimp.
2. The above specifications are guidelines to an optimum crimp.

**PARTS LIST**

<b>FineAdjust Applicator 63863-2000</b>				
<b>Item</b>	<b>Order No</b>	<b>Engineering No.</b>	<b>Description</b>	<b>Quantity</b>
<b>Perishable Tooling</b>				
	63863-2070	63863-2070	Tool Kit (All "Y" Items)	REF
1	63863-2002	63863-2002	Conductor Punch	1 Y
2	63445-1213	63445-1213	Conductor Anvil	1 Y
3	63863-2003	63863-2003	Insulation Punch	1 Y
4	63445-1615	63445-1615	Insulation Anvil	1 Y
5	63443-0003	63443-0003	Cut-Off Plunger	1 Y
6	63443-0012	63443-0012	Front Plunger Retainer	1 Y
<b>Other Components</b>				
7	11-18-4083	60707-8	Front Cover	1
8	11-24-1067	4996-4	Cut-off Plunger Spring	1
9	11-40-4039	8302-5	Front Plunger Striker	1
10	63443-0009	63443-0009	Scrape Chute	1
11	63443-0021	63443-0021	Lower Tooling Key	1
12	63443-2411	63443-2411	Anvil Mount	1
13	63443-4029	63443-4029	Wire Stop	1
14	63443-6001	63443-6001	Rear Cover	1
15	63445-1613	63445-1613	Spacer Anvil	1
<b>Frame</b>				
16	63800-4901	63800-4901	Top	1
17	63801-3281	63801-3281	Base	1
18	63801-4650	63801-4650	Track	1
<b>Hardware</b>				
19	N/A	N/A	M3 by 6 Long SHCS	2**
20	N/A	N/A	M4 by 6 Long SHCS	1**
21	N/A	N/A	M4 by 12 Long BHCS	2**
22	N/A	N/A	M4 by 16 Long SHCS	1**
23	N/A	N/A	M4 by 20 Long SHCS	1**
24	N/A	N/A	M4 by 50 Long SHCS	1**
25	N/A	N/A	3mm by 6 Long Roll Pin	1**
26	N/A	N/A	#10-32 by 1/4" Long BHCS	1**
** Available from an industrial supply company such as MSC (1-800-645-7270).				

### Assembly Drawing

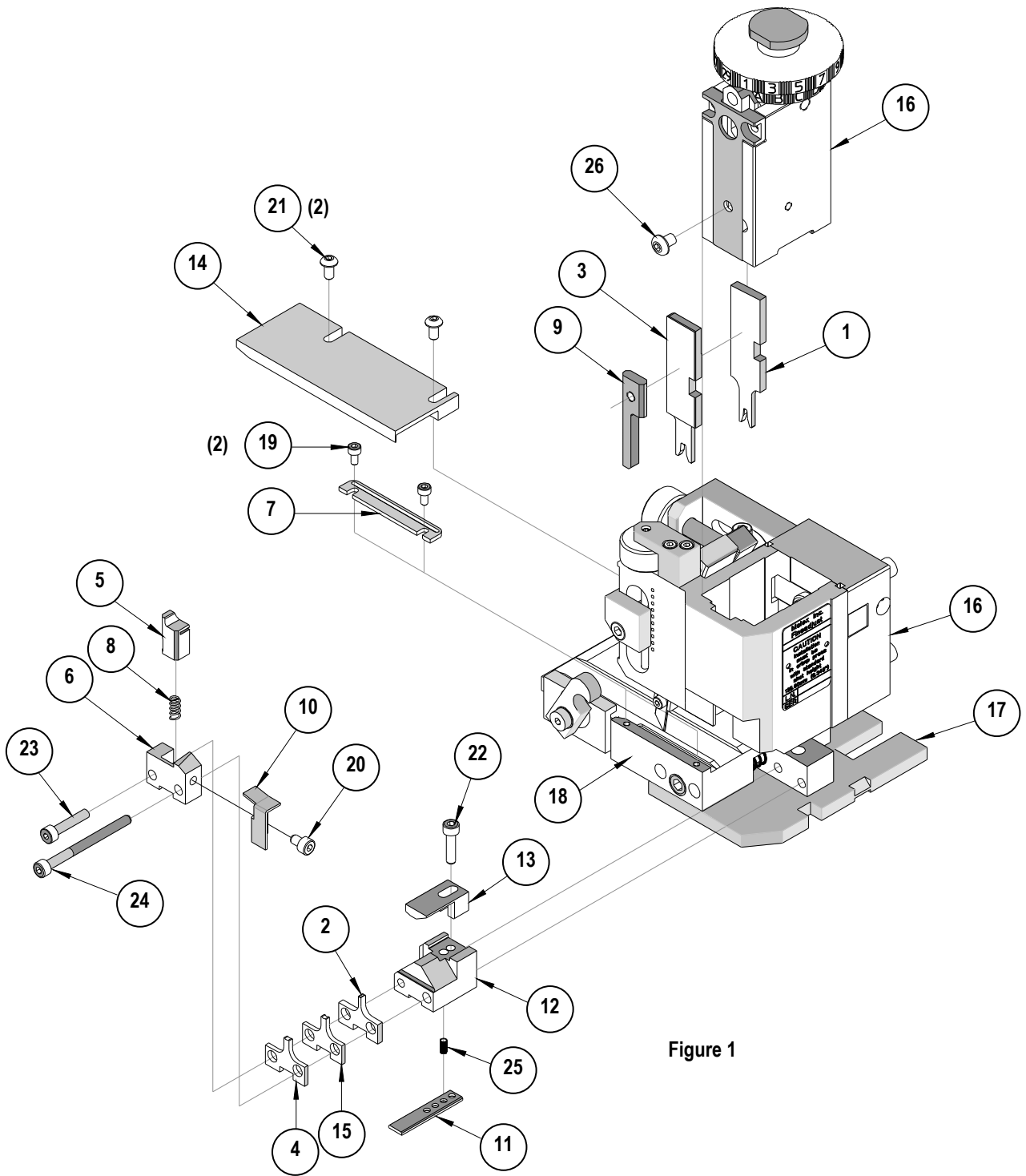

Figure 1

## NOTES

1. Molex recommends an extra perishable tooling kit be maintained at your facility.
2. Verify tooling alignment by manually cycling the press and Applicator before crimping under power. Check that all screws are tight.
3. Slugs, Terminals, Dirt and Oil should be kept clear of work area.
4. Wear safety glasses at all times.
5. For recommended maintenance refer to the FineAdjust Manual.

**CAUTION:** This applicator should only be used in a press with a shut height of 135.8mm (5.346"). Tooling damage could result at a lower setting.

**CAUTION:** To prevent injury never operate this Applicator without the guards supplied with the press or wire-processing machine in place. Reference the press or wire processing manufacturer's instruction manual.

**CAUTION:** Molex crimp specifications are valid only when used with Molex terminals, applicators and tooling.

Visit our Web site at <http://www.molex.com>

# Mouser Electronics

Authorized Distributor

Click to View Pricing, Inventory, Delivery & Lifecycle Information:

[Molex:](#)

[63863-2070](#)