



RoHS
Ready 

AMP Metrimate Pin and Socket Connectors

Product Facts

- Recognized under the Component Program of Underwriters Laboratories Inc., File No. E28476 
- Certified by Canadian Standards Association, File No. LR7189 
- Tested to VDE requirements outlined in VDE Test Report No. 4751-1431-1029/AII 
- Produced under a Quality Management System certified to ISO 9001 
A copy of the certificate is available upon request.
- Designed to meet IEC (440 V) requirements
- True metric dimensions—contacts on 5 [.197] centers (drawer connectors and special in-line connectors and pin headers have contacts on 5.08 [.200] centers)
- Panel mount versions require no hardware for mounting
- Polarized housings
- 4- thru 36-position square grid configurations can be mounted to and removed from either front or rear of panel
- Housings made of UL rated 94V-0 thermoplastic
- Strain reliefs available for 6- thru 36-position square grid, panel mount housings
- Drawer connectors available in 4- thru 30-position sizes, standard and low profile versions

AMP Metrimate connectors are true metric specification connectors designed for panel, free-hanging or pc board application. These connectors offer improvements in durability, density and electrical performance over competitive soft shell pin and socket connectors. They are ideally suited for equipment manufacturers engaged in both national and international markets. This versatile pin and socket connector line is designed to meet the general requirements of various testing and approval agencies, including UL, CSA, VDE and IEC.

Presently, connectors are available in various design configurations and the most popular sizes to satisfy a variety of application requirements. Such designs include: square grid connectors for free-hanging and/or panel mounting; free-hanging in-line connectors; square grid and in-line pin and socket headers for pc board mounting; and drawer connectors for rack and panel mounting with radial float.

For high electrical performance and maximum economy, all connectors employ housings made of UL rated 94V-0 thermoplastic.

Table of Contents

Performance Characteristics 3-5

Metrimate Connector Applications 6-8

Contacts:

- Type III+ (Crimp)..... 9
- Type III+ (Grounding Pins)..... 10
- Type III+ (Solder) 9-10
- High Current Upgrade, Type II and III+..... 11-12
- Subminiature Coaxial 13-14
- Size 8, Power 15
- High Current Upgrade, Size 8, Power 16
- .125 POWERBAND Contacts 17

Drawer Connectors..... 18-26

Low Profile Drawer Connectors 27-30

Square Grid Connectors (Free-Hanging and Panel Mount) 31-33

Strain Relief Kits for Square Grid Connectors..... 31

Square Grid PC Board Mount Headers..... 34-38

In-Line Connectors (Free-Hanging), 5 [.197] Centerline 39-40

In-Line PC Board Mount Headers, 5 [.197] Centerline 41-43

Keying Plugs..... 44

In-Line Connectors, 5.08 [.200] Centerline 44-47

In-Line Coaxial Socket Headers 48-51

Rectangular Connectors 52-53

Commoning and Power Distribution Connectors ... 54-55

Application Tooling 56-57

Technical Documents..... 61

Part Number Index 62

Need more information?

Call Technical Support:
1-800-522-6752

The Center is staffed with specialists well versed in Tyco Electronics products. They can provide you with:

- Technical Support
- Catalogs
- Technical Documents
- Product Samples
- Tyco Electronics Authorized Distributor Locations

Dimensioning:

Dimensions are in millimeters and inches. Values in brackets are equivalent U.S. Customary Units. Metric symbols used are:
C (Celsius)
mm² (square millimeter)

Note: Dimensions in this catalog are for reference purposes only. Customer drawings are available on request.

Specifications subject to change. Consult Tyco Electronics for latest design specifications.

©1978, 1979, 1983, 1985, 1989, 1994, 1998, 2003 and 2008 by Tyco Electronics Corporation. All Rights Reserved.

ACTION PIN, AMP, AMPOMATOR, AMP-O-ELECTRIC, AMP-O-MATIC, CERTI-CRIMP, COAXICON, LGH, POWERBAND, PRO-CRIMPER and TYCO are trademarks.

Performance Characteristics

Electrical Characteristics

Voltage Rating: UL (600 VAC and VDC), CSA (600 VAC and VDC), VDE (380 VAC, 450 VDC), IEC (440 V)

Dielectric Strength: 2000 Volts, RMS (at sea level)

Current Rating: See contact current carrying capability data below.

Insulation Resistance: 5000 Megohms (Min.)

Termination Resistance: Dependent upon individual contact type. Refer to applicable Product Specification. (Technical Documents, page 58).

Environmental Characteristics

Temperature Range: -55°C to +130°C [-67°F to +266°F]

Mechanical Characteristics

Air Gap: Exceeds 3.2 [.125]

Creep Distance: Exceeds 4 [.157]

Mounting Distance (Live Contact-to-Panel): Exceeds 6 [.237]

Acceptable Panel Thicknesses: 0.8-2.3 [.030-.090]

Contact Current Carrying Capability

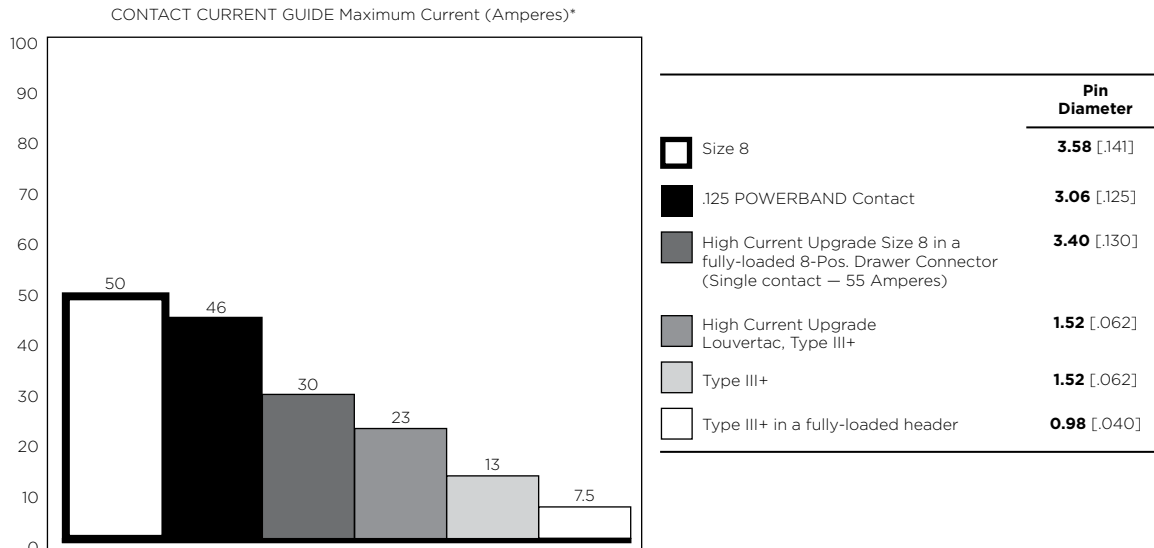

*Based on single contact free air conditions.

1. .125 POWERBAND - Precision formed pins & sockets.

2. High Current Louvertac - Screw machined pin & socket contacts.

Both versions feature the AMP Louvertac springs for superior current carrying, heat transfer and durability performance. See catalog 65141.

The total current capacity of each contact in a connector is dependent upon the heat rise resulting from the combination of electrical loads on all the contacts in the connector arrangement and the maximum ambient temperature in which the connector will be operating. Caution must be taken to assure that these combinations of conditions do not cause the internal temperature of the connector to exceed the maximum operating temperature of the housing material. There are several variables which must be considered when determining this maximum current carrying capability for your application.

These variables are:

- Wire Size-Larger wire will carry more current since it has less resistance to current flow; therefore, it generates less heat. The wire also conducts heat away from the connector.
- Connector Size-In general, the more circuits in a connector, the less current per contact can be carried.
- Ambient Temperature - The higher the ambient temperature, the less current can be carried.

Performance Characteristics (Continued)

Current Rating Verification

Can a contact rated at 10 amperes carry 10 amperes?

Maybe yes, but probably not. The reason lies in the test conditions used to rate the contact. If these conditions do not adequately reflect the application conditions, the actual allowable current levels may be lower than specified levels. For example, many manufacturers, including Tyco Electronics, test a single contact in air. This gives an accurate measure of the basic current-carrying capacity of the contact. Use the contact alone in air and it can certainly carry 10 amperes. Use it in a multi-position connector surrounded by other current-carrying contacts or in high ambient temperatures, and the contact should carry less current.

Similarly, as the contact ages and stress relaxation, environmental cycling, and other degradation factors take their toll, the contact's current-carrying capacity decreases. A prudent design must set current levels for such end-of-design-life (EODL) conditions.

Practical current-carrying capacity is not an absolute, but an application-dependent condition.

New Method Simplifies Ratings

To help the designer set the appropriate current level, Tyco Electronics has developed a method of specifying current-carrying capacity. This method takes into account the various application factors that influence current rating.

The method can be summarized as follows:

- The contact is aged to EODL conditions by durability cycling, thermal cycling, and environmental exposure.
- The contact's resistance stability is verified.
- The current necessary to produce the specified temperature rise is measured. This T-rise is usually 30°C.
- A rating factor is determined to allow derating of multiple contacts in the same housing and for different conductor sizes.

Temperature

One other factor influencing current levels is the maximum operating temperature, for example, 105°C. If the application has a high ambient temperature (over 75°C) the contact's T-rise is limited by the maximum operating temperature. For example, an application temperature of 90°C limits the contact T-rise to 15°C. Since current produces heat (the I²R law), the current must be lowered to limit the T-rise.

A contact's T-rise depends not only on its I²R Joule heating, but also on its ability to dissipate the heat. Consider a contact in a multi-contact housing. Joule heating in multiple contacts will raise the local ambient temperature. Since the contact will not be able to dissipate its own heat as well by convection, the maximum T-rise will be realized at a lower current level. Consequently, the allowable current level must be lower to maintain an acceptable T-rise.

For a given connector, the current level will be set by the loading density. A connector containing 50% current-carrying contacts will permit higher currents (per contact) than a connector will at 75% loading. The loading percentage assumes an even distribution of contacts within the housing. If all 10 contacts are grouped together in one section of a 20-position connector, the loading density may approach 100%.

The Importance of EODL

As stated, T-rise in a contact depends on both resistance and current. As it ages, a contact's resistance will increase. The contact designer will specify a maximum resistance for the contact, this level is the end-of-design-life resistance. Before the contact is tested for current, Tyco Electronics subjects it to a sequence of tests that exercise many major failure mechanisms and thereby simulates EODL conditions. Conditioning includes mating cycling, industrial mixed-flowing gases, humidity and temperature cycling, and vibration to sequentially introduce wear, corrosion, stress relaxation, and mechanical disturbance.

Presentation

The presentation of current-carrying capacity in Tyco Electronics product specifications includes two parts:

- First, a base curve showing current levels versus T-rise for a single circuit and the largest wire size. This represents the maximum current capacity of the

Performance Characteristics (Continued)

contact. The curve is usually flat up to 75°C ambient and then drops off. Up to 75°C, the 30°C T-rise limits the amount of current, and above 75°C the current must be reduced to keep the combination of ambient temperature and T-rise from exceeding the maximum operating temperature of 105°C.

- Next are rating factors, a table of multipliers to account for connector loading and for smaller wire sizes. The designer first determines the base current for the ambient conditions of the application, then multiplies this base current by the rating factors to find the current level for the application's loading factor and wire size.

Practical Values

The current-rating method gives designers practical values applicable to their applications. While the specified current levels for a contact may be lower than for other testing methods, they are more realistic and simplify the system design process.

"Spec-manship" is replaced by a realistic assessment of the current-carrying capacity of a contact under varying conditions of temperature, connector loading, and wire size.

An Example:

To demonstrate the method of specifying current, consider the following application conditions, an ambient temperature of 65°C, a 50% loading of contacts in the housing, and 20 AWG [0.6 mm²] wire.

- From Figure 1, the base current rating is 14 ampere with 18 AWG [0.8 mm²] wire.
- Figure 2, the rating factor for 50% loading and 20 AWG [0.6 mm²] wire is 0.68.
- The specific rating for this application is the product of the base rating and the rating factor:
 $14 \times 0.68 = 9.5$ ampere
- Each of the contacts can carry 9.5 ampere.
- However, if the ambient temperature is 80°C the allowable T-rise becomes 25°C. The base current must be lowered to 12.8 ampere so that the 105°C maximum operating temperature is not exceeded. The current rating then becomes:
 $12.8 \times 0.68 = 8.7$ ampere.

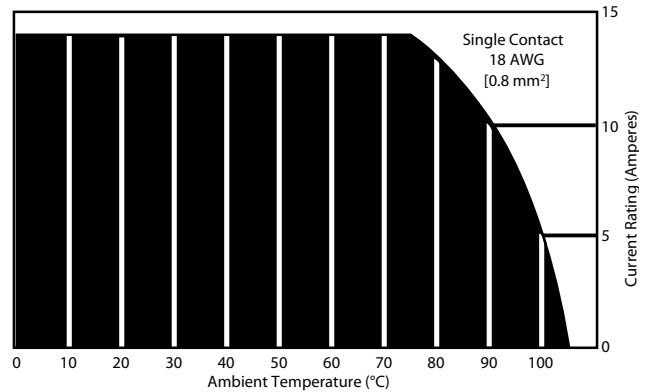

Figure 1

Graph shows the relationship between base current, ambient temperature, and contact T-rise.

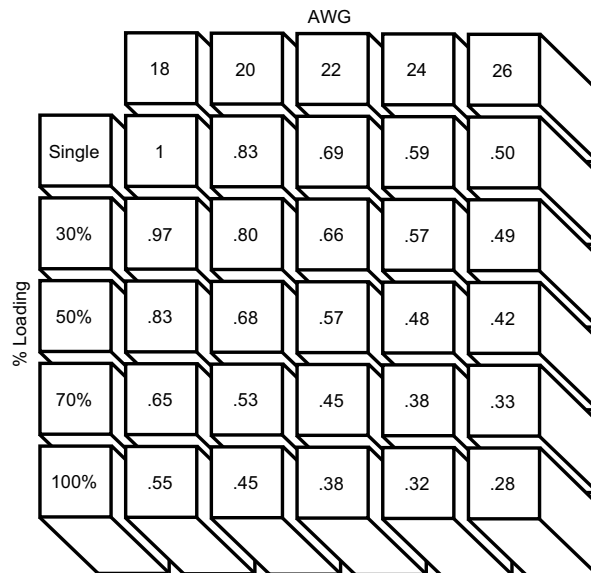

Figure 2

Rating factors allow the base current to be adjusted for various connector loading and wire sizes.

Metrimate Connector Applications

Drawer Connectors

Standard Drawer Connectors, Rack and Panel Applications

Plug

4, 12, 19 and 25 Position
Connectors; 8 and 15 Position
Power Connectors
(Pages 18, 19)

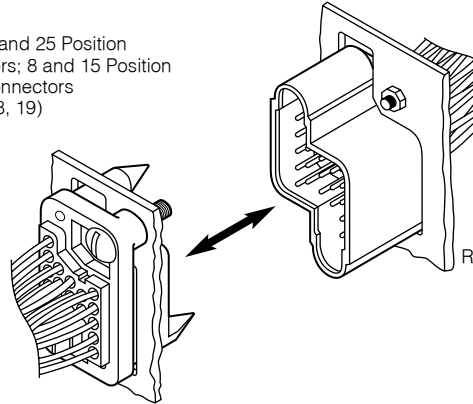

Receptacle

4, 12, 19 and 25 Position
Connectors; 8 and 15 Position
Power Connectors
(Pages 18, 19)

Standard Drawer Connectors, Wire-To-Board

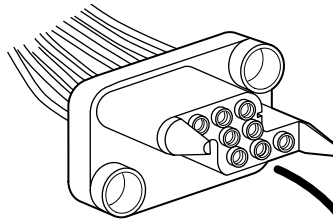

Plug

12, 19 and 25 Position Pin Headers (Solder);
25 Position Pin Header (ACTION PIN Contacts);
8 and 15 Position Power Drawer Pin Headers
(Pages 18, 19)

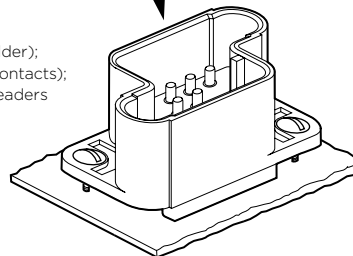

Receptacle

25 Position Socket
Headers (Solder); 8 and
15 Position Power Drawer
Socket Headers
(Pages 18, 19)

Low Profile Drawer Connectors, Wire-To-Board, and Wire-To-Wire

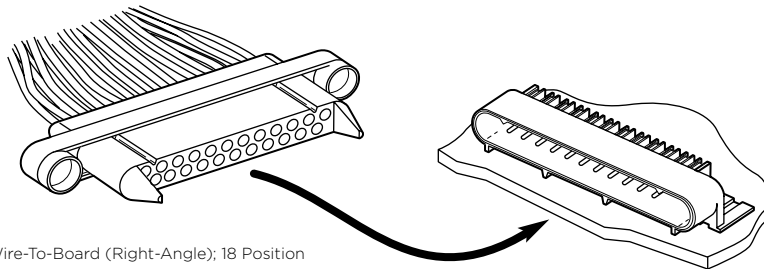

23 Position Wire-To-Board (Right-Angle); 18 Position
Hybrid (5 Power, 13 Signal) Wire-To-Board (Right-Angle);
30 Position Wire-To-Wire
(Page 27)

Metrimate Connector Applications (Continued)

Square Grid Connectors

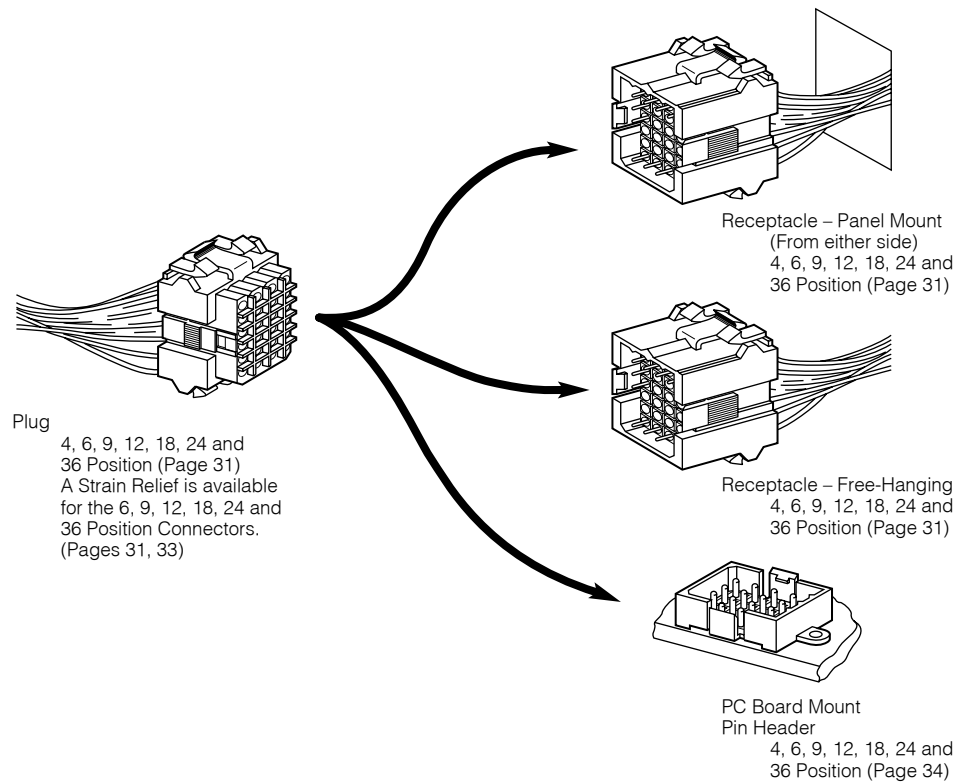
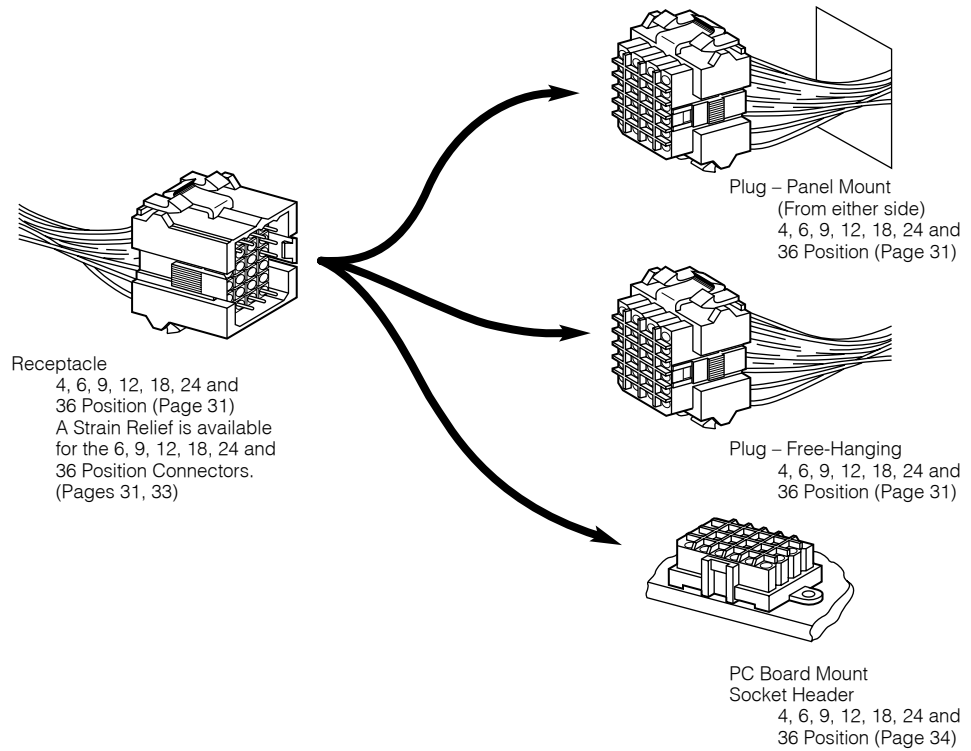

Metrimate Connector Applications (Continued)

In-Line Connectors

Metrimate Connector Applications

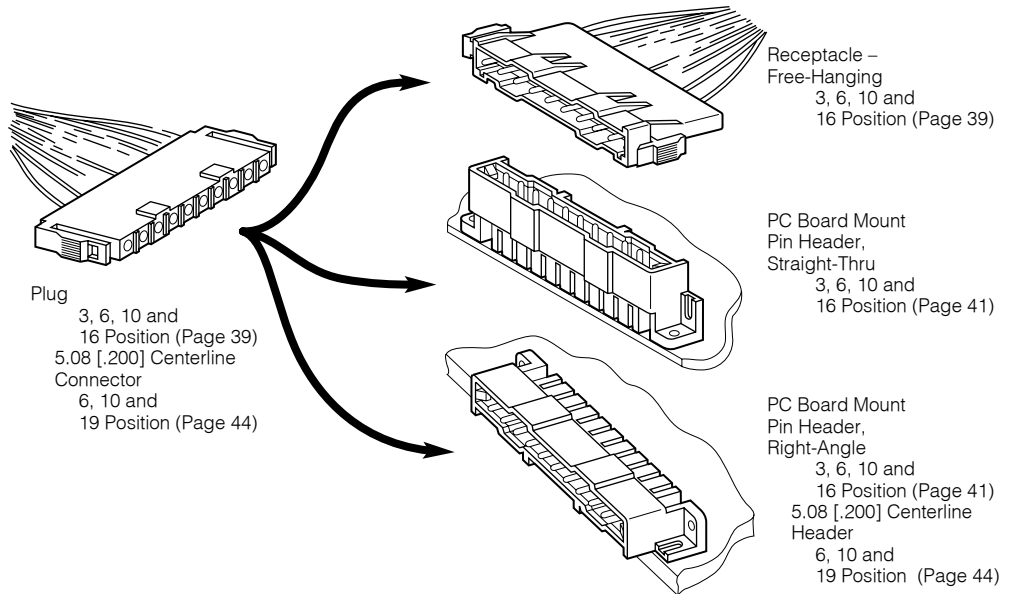
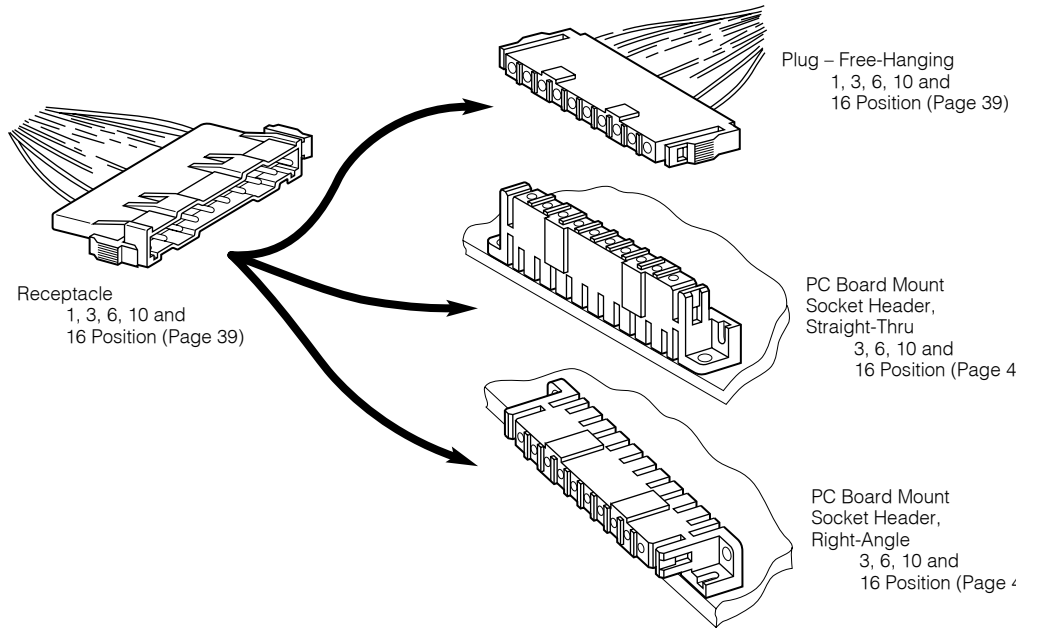

Signal Contacts

Type III+, Crimp, Snap-In

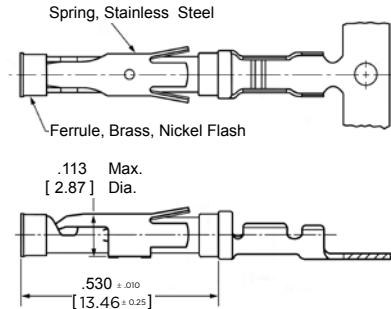
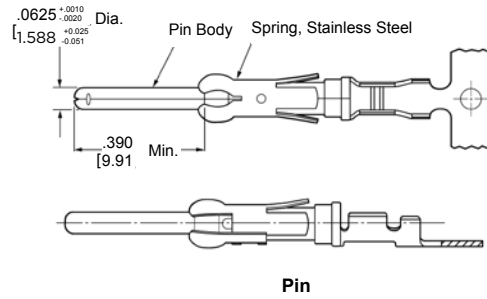
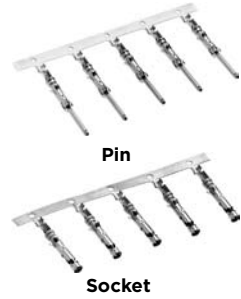

Related Product Data

Application Tooling - Pages 76-79

Technical Documents

114-10004 application Specification
108-10024-2 Product Specification

Material and Finish - See chart
Contact Body - Copper Nickel Alloy
Retention Spring - Stainless steel

Contact Size 16 - Pin Diameter .062 [1.57] (Test Current, 13 Ampere)†

† Single contact, free-air test current is not to be construed as contact rating current. Use only for testing. Refer to contact current carrying capability information on page 8.

Wire Size Range AWG mm ²	Ins. Dia. Range	Contact Finish	Strip Form Contact No.		Loose Piece Contact No.		Tooling Part No.	
			Pin	Socket	Pin	Socket	Loose Piece Hand Tool	Strip Form Applicators
30-28 0.05-0.09	.015-.030 0.38-0.76	Gold/Nickel ²	788085-3	788088-2	—	—	90716-1	567867-1***
		Sel. Gold/Nickel ³	788085-1	788088-1	788085-4	788088-3		or 567947-1*** or 680602-□***
30-26 0.05-0.15	.040-.060 ¹ 1.02-1.52	Bright Tin	1-66425-2	1-66424-1	—	—	91515-1 ⁶	466598-□***
		Gold/Nickel ²	66425-7	66424-7	66429-3	66428-3		
		Sel. Gold/Nickel ³	66425-8	66424-8	66429-4	66428-4		
		Gold/Nickel ²	66393-7	66394-7	—	—		
26-24 0.12-0.2	.035-.055 ¹ 0.89-1.40	Sel. Gold/Nickel ³	66393-8	66394-8	66406-4	66405-4	90225-2 ⁶	466585-3***
		Bright Tin	1-66106-5	1-66108-5	1-66107-1	1-66109-7		
		Gold/Nickel ²	66106-7	66108-7	66107-3	66109-3		
		Sel. Gold/Nickel ³	66106-8	66108-8	66107-4	66109-4		
		Sel. Gold/Nickel ⁴	—	66108-1	—	66109-1		
		Bright Tin	2-66102-5	3-66104-0	1-66103-8	1-66105-9		
24-20 0.2-0.6	.040-.080 ¹ 1.02-2.03	Gold/Nickel ²	66102-8	66104-8	66103-3	66105-3	91515-1 ⁶	466323-□***
		Sel. Gold/Nickel ³	66102-9	66104-9	66103-4	66105-4		
		Sel. Gold/Nickel ³	2-66102-2	2-66104-3	1-66103-2	1-66105-3		
		Sel. Gold/Nickel ⁴	—	66104-1	—	66105-1		
		Bright Tin	1-66564-2	1-66563-1	66566-7	66565-7		
		Sel. Gold/Nickel ³	66564-8	66563-8	66566-4	66565-4		
18-16 0.8-1.4	.080-.100 ¹ 2.03-2.54	Bright Tin	1-66332-4	1-66331-4	1-66400-0	1-66399-0	91523-1 ⁶	466324-□***
		Gold/Nickel ²	66332-7	66331-7	66400-3	66399-3		
		Sel. Gold/Nickel ³	66332-8	66331-8	66400-4	66399-4		
		Sel. Gold/Nickel ⁴	—	66331-2	—	66399-2		
		Bright Tin	1-66098-9 ⁵	1-66100-9	1-66099-5	1-66101-9		
		Gold/Nickel ²	66098-8	66100-8	66099-3	66101-3		
18-14 0.8-2.0	.080-.100 ¹ 2.03-2.54	Sel. Gold/Nickel ³	66098-9	66100-9	66099-4	66101-4	91519-1 ⁶	466326-□*** or 466923-2***
		Sel. Gold/Nickel ⁴	66098-6	—	66099-1	—		
		Bright Tin	1-66359-4	1-66358-6	1-66361-2	1-66360-2		
		Gold/Nickel ²	66359-9	66358-9	66361-3	66360-3		
		Sel. Gold/Nickel ³	1-66359-0	1-66358-0	66361-4	66360-4		
		Sel. Gold/Nickel ⁴	1-66359-2 ⁷	1-66358-3 ⁷	66361-8 ⁷	66360-8 ⁷		
.110-.150 ⁵ 2.79-3.81	Bright Tin	66597-8	66598-9	66602-8	66601-9	91521-1 ⁶	466958-1*** or 567364-□***	
		Sel. Gold/Nickel ³	66597-2	66598-2	66602-2			66601-2

¹ Overall insulation crimp diameter, including crimp barrel, must not exceed .125 [3.18].
² .000015 [0.00038] gold in the mating area over .000050 [0.00127] min. nickel.
³ .000030 [0.00076] gold in the mating area, with gold flash on remainder, over .000050 [0.00127] min. nickel.
⁴ .000030 [0.00076] gold in the mating area, with gold gradient on remainder, over .000050 [0.00127] min. nickel.

⁵ Contacts can ONLY be used in: Metrimate; CPC Series 1 (Arr. 23-24), Series 4 (Arr. 23-13M, 23-16M, 23-22M), and VDE connectors.
⁶ To use with the 626 Pneumatic Tool, remove crimping head from Straight Action Hand Tool (SAHT), order SAHT Adapter Part No. 217201-1. Adapter Holder Part No. 356304-1 (with ratchet) or 189928-1 (without), and Power Unit Part No. 189721-1 (hand actuated) or 189722-1 (foot actuated).
⁷ Phosphor bronze contact body

⁵ Standard reeling of strip form contacts.
⁶ Commercial PRO-CRIMPER II hand tool for field repair only. Note: Die Set can be adapted for use with 626 Pneumatic Tool System. Insertion Tool Part No. 91002-1 (for insulation diameters .070 [1.78] or less). No. 200893-2 (for insulation diameters .090 [2.29] max.). Extraction Tool Part No. 305183. (Instruction Sheet 408-1216)
*** Call Technical Support for Machine Applicator Part Numbers.

Signal Contacts (Continued)

Type III+, Crimp, Snap-In

Contact Size - 16
Pin Diameter - 1.57 [.062]

Material and Finish

Contact Body - Copper alloy,
plated tin or gold
Spring - Stainless steel

Grounding Pin

(make first - break last)

Related Product Data

Application Tooling -
Pages 56, 57
Technical Documents -
Page 58

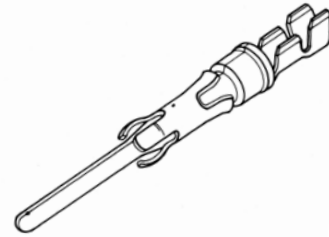

Wire Size Range		Ins. Dia. Range ¹	Contact Finish	Grounding Pin Part No.		Strip Form Applicator Part No.	Loose Piece Hand Tool Part No.
[mm ²]	AWG			Strip Form	Loose Piece		
0.12-0.2	26-24	0.89-1.4 .035-.055	Tin	164159-3	164162-1	-	91515-1 ³ or 58495-1*
			Sel. Gold/Nickel ²	164159-4	164162-2		
0.2-0.6	24-20	1.14-1.78 .045-.070	Bright Tin	164160-3	164163-1	466323-□ ^{***}	91515-1 ³ or 91505-1 ³ or 58495-1*
			Sel. Gold/Nickel ²	164160-4	164163-2	466907-2 ^{***}	
0.8-1.4	18-16	1.98-2.49 .078-.098	Tin	164161-3	164164-1	466741-□ ^{***}	91523-1 ³ or 91505-1 ³ or 58495-1*
			Sel. Gold/Nickel ²	164161-4	164164-2	680114-3 ^{***}	

¹Overall insulation crimp diameter, including crimp barrel, must not exceed 3.18 [.125].

²Gold flash over 0.00076 [.000030] min. nickel on entire contact, with 0.00076 [.000030] gold in contact area.

³To use with the 626 Pneumatic Tool System: remove the crimping head from the Straight Action Hand Tool (SAHT) Assembly, order SAHT Adapter Part No. (Call Technical Support), Adapter Holder Part No. 356304-1 (with ratchet) or 189928-1 (without), and Power Unit Part No. 189721-1 (hand actuated) or 189722-1 (foot actuated).

*Commercial PRO-CRIMPER II hand tool for field repair only. Note: Die Set can be adapted for use with the 626 Pneumatic Tool System.

***Call Technical Support for Automatic Machine Applicator Part Numbers.

Extraction Tool Part No. 725840-1

Type III+ (Precision Formed, Solder)

Contact Size - 16
Pin Diameter - .062 [1.57]

Material and Finish

Contact Body - Copper alloy,
plated tin to gold
Spring - Stainless steel

Related Product Data

Performance Characteristics -
Page 6
Technical Documents -
Page 80

Solder-Type

(with Preformed Wire Barrel/
Insulation Support)

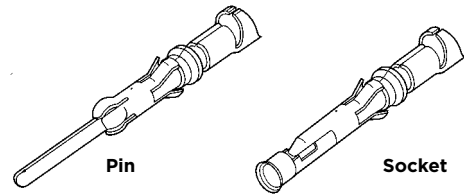

Solder-Tab

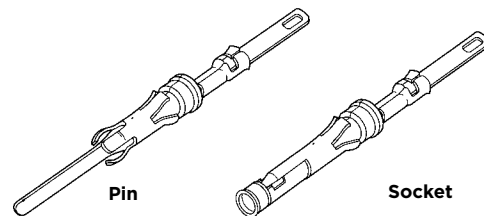

Contact Size 16—Pin Diameter .062 [1.57] (Test Current, 13 Ampere)‡

Wire Size Range		Contact Finish	Loose Piece Contact No.	
AWG	mm ²		Pin	Socket
26-20	0.12-0.6	Gold/Nickel ¹	66182-1	66183-1
18-16	0.8-1.4	Gold/Nickel ¹	66180-1	66181-1
Solder Tab ⁴		Duplex ²	202236-7	202237-7
		Bright Tin	202236-5	202237-5

¹.000030 [0.00076] gold in mating area over .000030 [0.00076] min. nickel.

²Duplex plated .000030 [0.00076] gold in mating area over .000030 [0.00076] min. nickel on contact body; bright tin on solder tab.

³Bright tin on entire contact.

⁴Designed for up to 14 AWG; but, not to exceed current limitation of contact.

Note: These contacts can be used in Multimater contact cavities of all connector housings.

‡Single contact, free-air test current is not to be construed as contact rating current. Use only for testing.

Refer to contact current carrying capability information on page 8.

Extraction Tool Part No. 305183

Power Contacts - High Current Upgrade

Type II and Type III+, Size 16

The features of the High Current Size 16 contact have been designed to fit into the existing AMP Multimate Connectors such as CPC (Circular Plastic Connector), CMC (Circular Metal Connector), G Series, M Series, Econoseal, Metrimate Square Grid and Drawer Connector housings. An initial T-Rise test in free air has shown a 23 amp capability with a 30°C T-Rise. The contact may be crimped onto 14 AWG wire with a Tyco Electronics hand tool P/N 601967-1. Use turret TH502 (1-601967-6) for the pin and turret TH501 (1-601967-5) for the socket.

Material

- Pin Body — Lead Brass; Copper Alloy (Board Mount)
- Socket Body — Copper Alloy
- Louvertac Band — Beryllium Copper
- Retention Spring — Stainless Steel
- Finish
- Body — Silver
- Louvertac Band — Gold



Extraction Tool Part No. 305183

Current-Carrying Capacity. The graph shows current-carrying capacity versus temperature rise for a fully energized 6 position Metrimate Square Grid plug P/N 207152-1 and receptacle P/N 207153-1. These initial representative amperage ratings were conducted with 14 AWG wires that were 2 feet long.

Wire Size AWG	High Current Size 16 Socket Part No.	
	Loose Piece	Tape
14	193846-1	193846-2
18-16	796966-1	796966-2

Wire Size AWG	High Current Size 16 Pin Part No.	
	Loose Piece	Tape
14	193844-1	193844-2
18-16	796964-1	796964-2

High Current Size 16 Pin (Board Mount) Part No. 194264-1

TEMPERATURE RISE VS. CURRENT

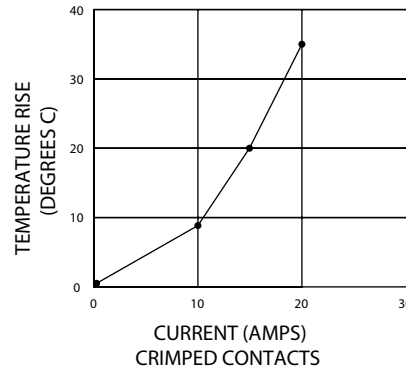

Current Rating for 30°C Temperature Rise 100% Energized

6 Circuit Metrimate Connector (Wire-to-Wire)

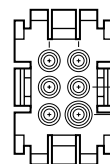
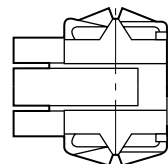
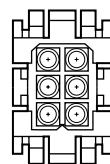
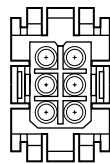
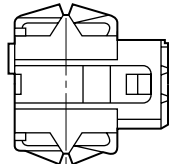

Plug (for Sockets)

Receptacle (for Pins)

- Notes:**
1. High Current contacts with Louvertac bands are NOT intermateable with any other contact.
 2. Additional information on CPC and CMC connectors is available in Catalog 82021.
 3. Additional information on G Series connectors is available in Catalog 82046.
 4. Additional information on M Series connectors is available in Catalog 82003.
 5. Additional information on Metrimate connectors is available in Catalog 82045.
 6. Additional information on Econoseal connectors is available in Catalog 82057.
 7. Additional information on LGH connectors is available in Catalog 82024.

Signal Contacts (Continued)

**Enhanced High Current
Type III+, Crimp, Snap-In**

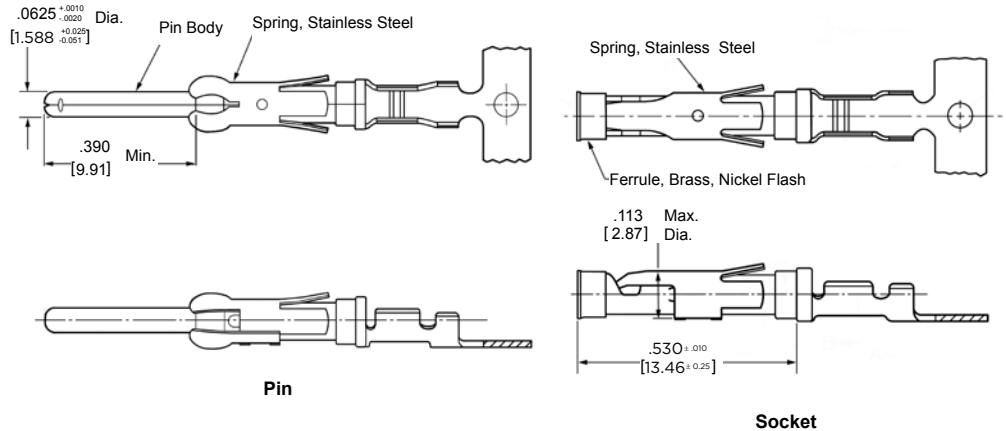

Material and Finish - See chart
Contact Body - Copper Nickel Alloy
Retention Spring - Stainless steel

Related Product Data
Application Tooling - Pages 76-79
Technical Documents
114-10004 application Specification
108-10024-2 Product Specification

Contact Size 16—Pin Diameter .062 [1.57]

Wire Size Range	Ins. Dia. Range	Contact Finish	Strip Form Contact No.		Loose Piece Contact No.		Tooling Part No.	
			Pin	Socket	Pin	Socket	Loose Piece Hand Tool	Strip Form Applicators
18-14	.080-.100 ¹ 2.03-2.54	Gold	1-66359-6	1-66358-9	1-66361-4	1-66360-4	91519-1 ³	466326-h*** or 466923-2***
		Tin	1-66359-9	2-66358-1	1-66361-6	1-66360-6		
	.110-.150 ² 2.79-3.81	Gold	1-66597-0	1-66598-1	66602-9	1-66601-0	91521-1 ³	466958-1*** or 567364-h***
		Tin	1-66597-1	1-66598-2	1-66602-0	1-66601-2		

¹ Overall insulation crimp diameter, including crimp barrel, must not exceed .125 [3.18].
² Contacts can ONLY be used in CPC, Series 1 (Arr. 23-24), Series 4 (Arr. 23-13M, 23-16M, 23-22M), and VDE connectors.
³ To use with the 626 Pneumatic Tool System: remove the crimping head from the Straight Action Hand Tool (SAHT) Assembly, order SAHT Adapter Part No. 217201-1, Adapter Holder Part No. 356304-1 (with ratchet) or 189928-1 (without), and Power Unit Part No. 189721-1 (hand actuated) or 189722-1 (foot actuated).
*** Call Technical Support for Automatic Machine Applicator Part Numbers.

Ratings

Base Current: Type III+ contacts: 13 amperes, 30°C temperature rise with single contact on 14 AWG wire in free air
Enhanced High Current Type III+ contacts: **24 amperes**, 30°C temperature rise with single contact on 14 AWG wire

Temperature: -55°C to +105°C

Contacts

Coaxial Contacts

Subminiature, Crimp, Snap-In, Size 16



Pin



Socket



Pin

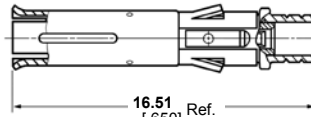

Socket



Ferrule

Part No. 225088-1-A 3.05 Dia. [0.120]

225088-3-A 3.12 Dia. [0.123]

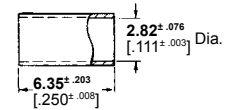

Ferrule
Part No. 1-332056-0

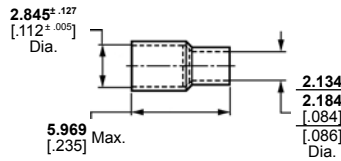

Ferrule

Part No. 1-332057-0

Selection Chart for Coaxial Cable

Cable Size (RG/U)	Contact Finish	Loose Piece Contact No.		Ferrule Part No.	Tooling Part No.	
		Pin	Socket		Die Inserts for Hand Tool 69710-1 or Pneumatic Tool ¹	Hand Tool
178, 196	Gold/Nickel Gold/Copper ¹	226537-2	51565-2	1-332057-0	69690-2	69656-2
	Gold/Nickel Gold/Copper ²	—	51565-5			
196 (Double Braid)	Gold/Nickel Gold/Copper ¹	226537-2	51565-2	225088-1	—	69656-9
	Gold/Nickel Gold/Copper ²	—	51565-5			
174, 188, 316	Gold/Nickel Gold/Copper ¹	226537-1	51565-1	1-332056-0	69690	91911-3**
	Gold/Nickel Gold/Copper ²	226537-4	51565-4			
174 (Double Braid)	Gold/Nickel Gold/Copper ¹	226537-1	51565-1	225088-3	—	69656-7
	Gold/Nickel Gold/Copper ²	226537-4	51565-4			
179, 187	Gold/Nickel Gold/Copper ¹	226537-1	51565-1	1-332056-0	69690-1	91911-4**
	Gold/Nickel Gold/Copper ²	226537-4	51565-4			
187 (Double Braid)	Gold/Nickel Gold/Copper ¹	226537-1	51565-1	225088-1	—	69656-8
	Gold/Nickel Gold/Copper ²	226537-4	51565-4			
161	Gold/Nickel Gold/Copper ¹	226537-1	51565-1	1-332056-0	—	69656-5
	Gold/Nickel Gold/Copper ²	226537-4	51565-4			

Material

Outer Shell - Brass per MIL-C-50

Center Conductor - Beryllium copper per QQ-C-533 (Pin); Brass per QQ-B-626 (Socket)

Inner Dielectric - Polypropylene

Retention Spring - Stainless steel per QQ-S-766

Ferrule - Copper per QQ-C-576 or ASTM-B-152 (1-332056-0)

Finish

Outer Shell, Center Conductor - See chart

Ferrule - Tin-lead per MIL-T-10727

Note: Subminiature Coaxial Contacts are used in Metrimate In-Line Plug and Receptacle Housings (page 39); NOT recommended for use in Metrimate Standard or Drawer Connectors.

¹Use hand actuated Power Unit **Part No. 189721-2** or foot actuated Power Unit **Part No. 189722-2**. Both units require "C" Head Die Set Adapter **Part No. 318161-1** and an Adapter Holder **Part No. 356304-1** (with ratchet) or **Part No. 189928-1** (without ratchet). Request Catalog 124208 for information on the 626 Pneumatic Tool System.

²Die Set used with PRO-CRIMPER II hand tool frame Part No. 354940-1.

Extraction Tool **Part No. 305183**

Coaxial Contacts (Continued)

Subminiature, Crimp, Snap-In, Size 16

(Continued)



Pin



Socket

Selection Chart for Twisted Pair and Shielded Wire

Wire Size AWG [mm ²]	Contact Finish	Loose Piece Contact No.		Ferrule Part No.	Tooling Part No.	
		Pin	Socket		Die Inserts for Hand Tool 69710-1 or Pneumatic Tool*	Hand Tool
30 0.05 (Twisted Pair, Solid)	Gold/Nickel Gold/Copper ¹	226537-3	51565-3	1-332057-0	69690-2	69656-2
28 0.08-0.09 (Twisted Pair, Solid)	Gold/Nickel Gold/Copper ¹	226537-3	51565-3	1-332057-0	69690	91911-3**
28 0.08-0.09 (Twisted Pair, Stranded 7 Str., .0050 [0.13] Dia.)	Gold/Nickel Gold/Copper ¹	226537-3	51565-3	1-332057-0	69690-1 or 69690-2	91911-4** or 69656-2
26 0.12-0.15 (Twisted Pair, Solid or Stranded 7 Str. .0063 [0.16] Dia.)	Gold/Nickel ¹ Gold/Copper	226537-3	51565-3	1-332057-0	69690	91911-3**
26 0.12-0.15 (Shielded, .075 [1.91] Max. O.D.)	Gold/Nickel Gold/Copper ¹	226537-1	51565-1	1-332057-0	69690-3	69656-3
	Gold/Nickel Gold/Copper ²	226537-4	51565-4			

¹0.00076 [.000030] gold over 0.00127 [.000050] nickel—outer shell and socket center conductor; 0.00076 [.000030] gold over 0.00254 [.000100] copper—pin center conductor.

²0.00127 [.000050] gold over 0.00127 [.000050] nickel—outer shell and socket center conductor; 0.00127 [.000050] gold over 0.00254 [.000100] copper—pin center conductor.

* Use hand actuated Power Unit **Part No. 189721-2** or foot actuated Power Unit **Part No. 189722-2**. Both units

require "C" Head Die Set Adapter **Part No. 318161-1** and an Adapter Holder **Part No. 356304-1** (with ratchet) or

Part No. 189928-1 (without ratchet). Request Catalog 124208 for information on the 626 Pneumatic Tool System.

**Die Set used with PRO-CRIMPER II hand tool frame Part No. 354940-1.

Note: A ferrule is required for each pin and socket.

Extraction Tool Part No. 305183

Material

Outer Shell - Brass per MIL-C-50

Center Conductor - Beryllium copper per QQ-C-533 (Pin); Brass per QQ-B-626 (Socket)

Inner Dielectric - Polypropylene

Retention Spring - Stainless steel per QQ-S-766

Ferrule - Copper per QQ-C-576 or ASTM-B-152 (1-332056-0)

Finish

Outer Shell, Center Conductor - See chart

Ferrule - Tin-lead per MIL-T-10727

Note: Subminiature Coaxial Contacts are used in Metrimate In-Line Plug and Receptacle Housings (page 39); NOT recommended for use in Metrimate Standard or Drawer Connectors.

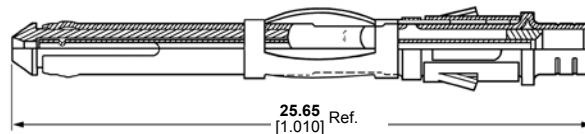

Pin

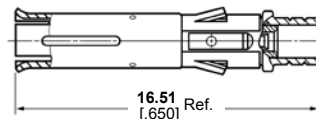

Socket

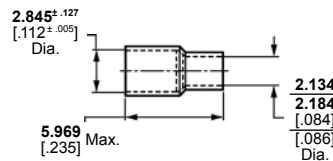

Ferrule
Part No. 1-332057-0

Power Contacts

Standard, Size 8, 4/8 Indent Crimp



Pin



Socket

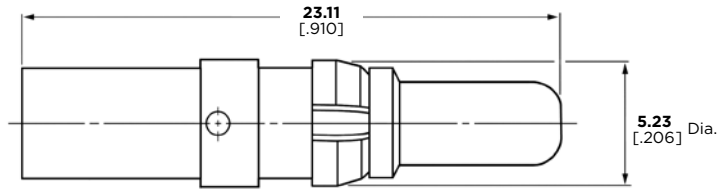

Pin

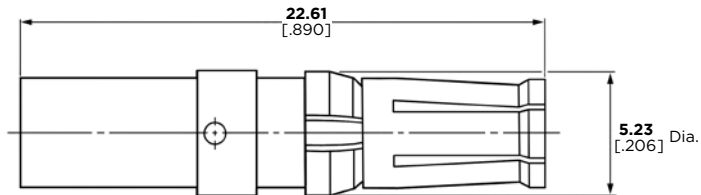

Socket

Note: Standard Size 8, High Current Upgrade Size 8 and .125 POWERBAND contacts are not intermateable.

Material

Contact Body - Copper alloy

Retention Clip - Phosphor bronze

Finish

Contact Body - 0.00127 [.000050] gold over 0.00127 [.000050] nickel

Retention Spring - Nickel plated

Related Product Data

Technical Documents

108-10045 Product Specification
114-10014 Application Specification

Power Contacts, Standard, Size 8 (Test Current 50 Amperes)‡

Wire Range AWG	[mm ²]	Contacts		Crimping Tools	
		Pin	Socket	Tool No.	Positioner
18-16	0.8-1.4	213567-1	212014-1	608668-1	(P) SP867 (S) 608668-2
14-12	2-3	213662-1	212008-1	608651-1	(P) SP867 (S) 608651-2
10	5	213740-1	213737-1	608651-1	(P) 608651-3 (S) 608651-2
8	8	213552-2	213750-1	608651-1	(P) 608651-3 (S) 608651-2

‡Single contact, free-air test current; not to be construed as contact rating current. Use only for testing. Refer to contact current carrying capability information, page 3.

Power Contacts - High Current Upgrade (Continued)

Metrimate Drawer Connector, Size 8

The Louvertac bands have the versatility of being designed into contact dimensions used in existing Tyco Electronics connectors.

Metrimate High Current contacts have been designed to fit into the existing Drawer Connector housings. A fully energized 8 position connector with 8 gage wires can handle 30 amps per line with a 30°C T-rise on either the cable-to-cable or cable-to-board.



Cable-to-Cable Material

- Contact Body** - Copper Alloys
- Louvertac Band** - Beryllium Copper
- Retention Spring** - Stainless Steel
- Finish** - Gold

Product Specification

108-1449 Metrimate Pin and Socket with Louvertac High Current Contact

Connector Voltage Rating - 600 VAC

- **Recognized under the Component Program of Underwriters Laboratories Inc.,** 
File No. E28476
- **Certified by Canadian Standards Association,** 
File No. LR7189A

Cable-to-Board Material

- Contact Body** - Copper Alloys
- Louvertac Band** - Beryllium Copper
- Retention Spring** - Stainless Steel
- Finish** - Gold

A typical application would have solder tail pins mounted into the receptacle and crimp socket mounted into the plug.

- **Recognized under the Component Program of Underwriters Laboratories Inc.,** 
File No. E28476
- **Certified by Canadian Standards Association,** 
File No. LR7189A

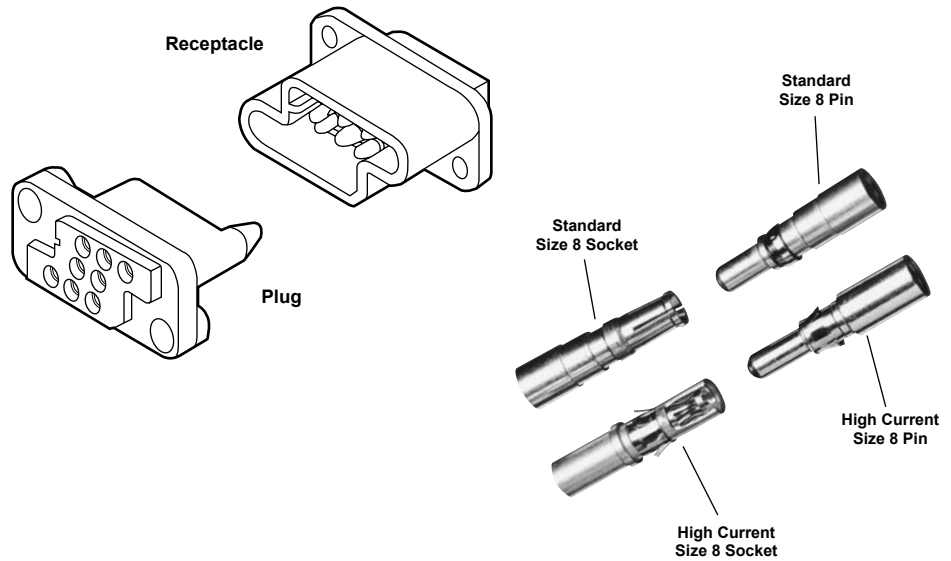

High Current Contacts

Wire Size		Contact Part Numbers		Crimp Tools
AWG	mm ²	Pin	Socket	
8	8	193457-1	193458-1	Daniels' Hand Tool #M310 or AMP P/N 356114-1 Positioner #TP944 or AMP P/N 356336-1
10	5	193642-1	193643-1	
12-14	3-2	193534-1	193535-1	

Extraction Tool Part No. 318813-1 or 305183-6

¹Daniels Manufacturing Corp., Orlando, FL

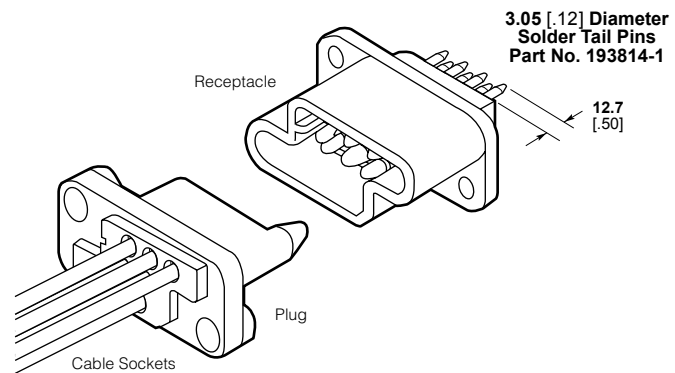

Drawer Connector Housings

Size Configuration	Housing Part Numbers	
	Plug	Receptacle
8 Positions (8 Size 8 Cavities)	213499-1	213500-1
15 Positions (3 Size 8 Cavities & 12 Size 16 Cavities)	213426-1	213427-1

Extraction Tool Part No. 318813-1

Power Contacts (Continued)

.125 POWERBAND Contacts

Pin Diameter - .125 [3.175]
Test Current - 50 Amperes†

Material and Finish

Contact - Copper
Spring - Beryllium copper

Plating Code

A. 0.00508 [.000200] min.
silver on contact area, 0.00127
[.000050] min. on remainder,
all over 0.00127 [.000050] min.
nickel underplate

B. 0.00076 [.000030] min.
gold on contact area, gold flash
on remainder, all over 0.00127
[.000050] min. nickel under-
plate

Related Product Data

Application Tooling - Pages 56,
57

Technical Document - Page 58

Extraction Tool

Part No. 318813-1

(Instruction Sheet 408-4374)

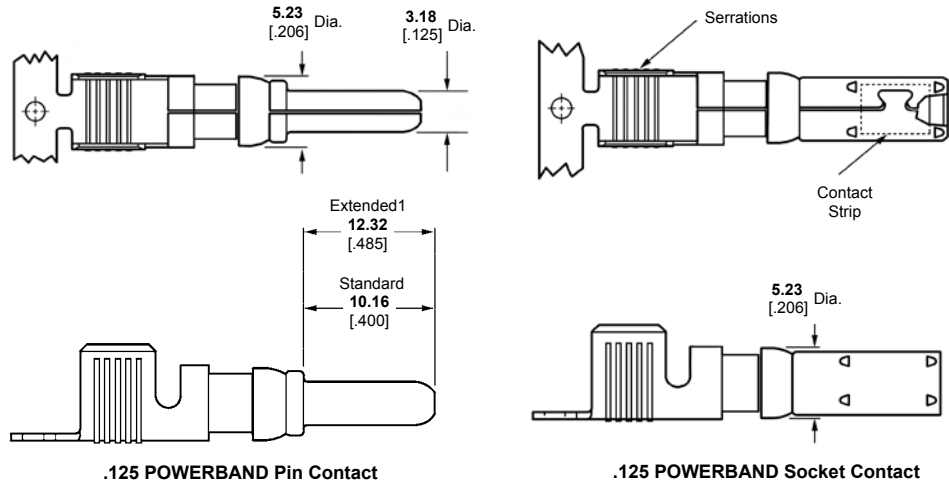

Wire Size AWG/mm ²	Contact Finish	Pin Length	Contact Part No.				Tooling Part No.	
			Strip		Loose Piece		Heavy Duty Miniature (HDM) Applicators (for AMP-O-LECTRIC Hand Tool 69710-1 Model G Machine, Base Part No. 354500)	Die Sets for AMP-O-LECTRIC Hand Tool 69710-1 or 626 Pneumatic Tool System*
			Pin	Socket	Pin	Socket		
14-12 2-3	A	Standard	213845-1	213847-1	213845-3	213847-3	680195-3	356612-1
	B	Standard	213845-2	213847-2	213845-4	213847-4		
	A	Extended ¹	213845-5	—	213845-7	—		
	B	Extended ¹	213845-6	—	213845-8	—		
10-8 5-8	A	Standard	213841-1	213843-1	213841-3	213843-3	680197-3	356611-1 (8 AWG)
	B	Standard	213841-2	213843-2	213841-4	213843-4		
	A	Extended ¹	213841-5	—	213841-7	—		356611-2 (10 AWG)
	B	Extended ¹	213841-6	—	213841-8	—		

¹For use in Metrimate Drawer Connectors listed in chart below and Two-Piece Sealed Circular Plastic Connectors (CPC), Series 5 and 6.

[†]Single contact, free-air test current; not to be construed as contact rating current. Use only for testing. Refer to contact current carrying capability information, page 3.

Note: Standard Size 8, High Current Upgrade Size 8, and .125 POWERBAND contacts are **not** intermateable.

*A typical 626 Pneumatic Tool System requires: a power unit (**Part No. 189721-2**, hand actuated or **189722-2**, foot actuated), an adapter holder (**Part No. 356304-1**, with ratchet), and "C" Head adapter **Part No. 318161-1**.

.125 POWERBAND Metrimate Drawer Connectors

No. of Pos.	Housing Part No.	
	Plug	Receptacle
8	213886-1**	213500-3**

Color: blue

**For use with .125 POWERBAND contacts (Extended Pin Length), listed above.

Drawer Connectors

Standard Drawer Connector Panel Mount

Product Facts

- 4-, 12-, 19- and 25-position connectors for Size 16 contacts
- 8-position connector for Size 8 power contacts, and a 15-position connector for 3 Size 8 power contacts and 12 Size 16 contacts
- Provides “blind” mating with up to 2.3 [.090] misalignment in any direction
- Guide pins molded into plug half
- Plug and receptacle can be front- or rear-panel mounted

Material

Black glass-filled thermoplastic, 94V-0 rated

Related Product Data

Contacts - Pages 9-17

Mounting Screw - Page 20

Keying Plug - Page 44

Dimensional Specifications and Recommended Panel Cutouts - Pages 21-26

Performance Characteristics -

Page 3

Technical Documents -

Page 58

Product Specifications -

108-10033

108-10045

Application Specifications -

114-10039

114-10014

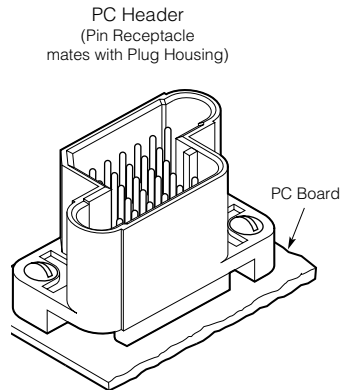
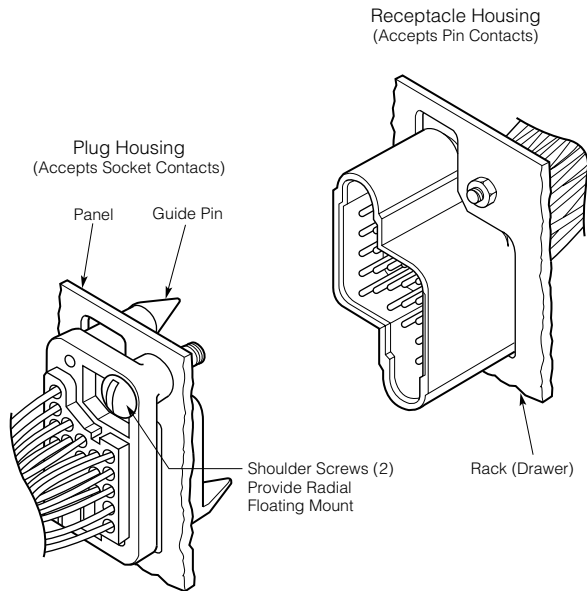

Standard Drawer Connectors

No. of Pos.	Connector Housing Part Nos.*			PC Header Part Nos.			Grounding Pins should not be used in these receptacle cavities
	Plug	Receptacle	Receptacle With 8/32 Inserts	Pin Headers Solder Tails	ACTION PIN	Socket Headers Solder Tails	
4	212608-1	212609-1	213749-1	—	—	—	1 and 4
12	211758-1	211759-1	213748-1	213824-3 ^A	—	—	1 and 12
19	208210-2	208209-2	—	213738-5 ^A	—	—	1 and 19
25	211150-1	211149-1	—	213672-3 ^A	1-796590-1 ^B 1-796590-2 ^C	213881-3 ^A	1 and 25

*Housings only, order contacts separately. See pages 9-12 for contact specifications.

PC Header Plating Code:

^AContact brass plated 0.00076 [.000030] min. gold on mating end, gold flash remainder, both over 0.00127 [.000050] min. nickel underplating. Post end brass plated 0.00254 [.000100] min. tin over 0.00254 [.000100] min. copper. Spring—Stainless steel.

^BContact phosphor bronze plated 0.00254 [.000100] min. tin over 0.00127 [.000050] min. nickel.

^CContact phosphor bronze plated 0.00076 [.000030] min. gold on the mating area, 0.00038 [.000150] min. tin on the ACTION PIN contact end, all over 0.00127 [.000050] min. nickel.

Note: Select loaded configurations including grounding pins can be made available; consult Tyco Electronics.

Drawer Connectors (Continued)

Power Drawer Connector, Size 8*

*For use with Size 8 contacts found on page 15

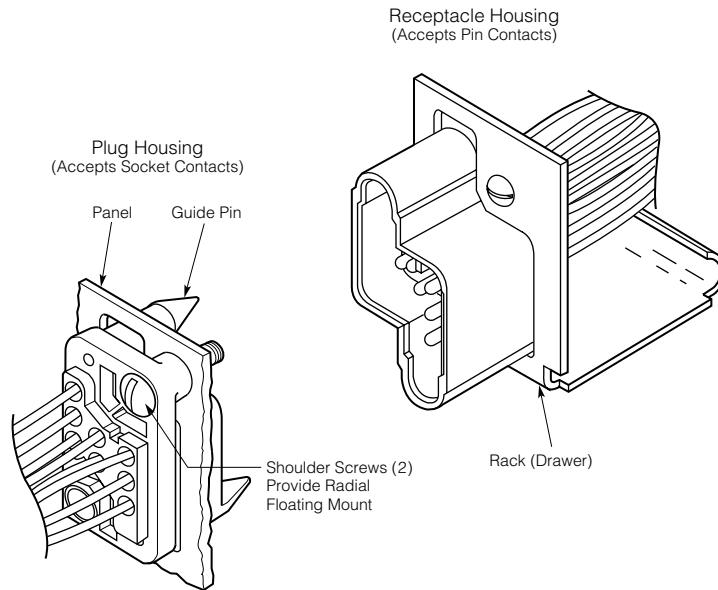

Blindmate Power Connectors

No. of Pos.	Housing Part No.*		With 8/32 Insert	PCB Headers	
	Plug	Receptacle		Pin	Socket
8 (8 size 8)	213499-1	213500-1	213752-1	213882-1	213883-1
15 (3 size 8, 12 size 16)	213426-1	213427-1	—	213713-2 ¹	213908-4 ¹

¹Loaded with Size 16 contacts only.

*Housing only, order contacts separately. See pages 15 and 16 for contact specifications.

Power Drawer Connector, .125 POWERBAND*

.125 POWERBAND Connectors

No. of Pos.	Housing Part No.		Color
	Plug	Receptacle	
8	213886-1*	213500-3	Blue
		213500-1	Black

*For use with .125 POWERBAND contacts found on page 17

Drawer Hardware

Mounting Screw

Material

Stainless steel

Thread Size	Part No.
M4 x 0.7-6H/6g	208211-1
SAE 6/32	208211-4

Note: These shoulder screws are used for mounting the plug housing and they provide float for positioning of misaligned connectors. Two are required for each plug. Mounting screws are to be ordered separately. Nuts are to be supplied by the customer.

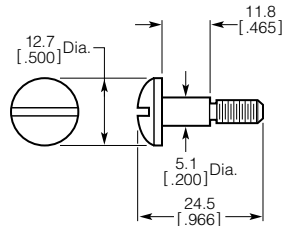

Thread Size - M4 x 0.7-6H/6g or
SAE 6/32

Drawer Connectors

Screw Kits

Part No. 213283-2

Kit Includes: 2—M4 screws,
2—Springs, 2—Washers

Screw Kits are recommended in order to compensate for misaligned connector halves and to provide float in X, Y, and Z directions.

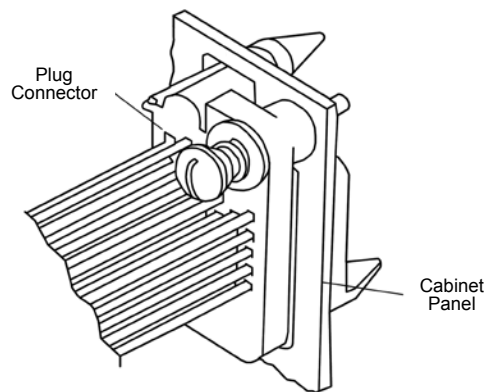
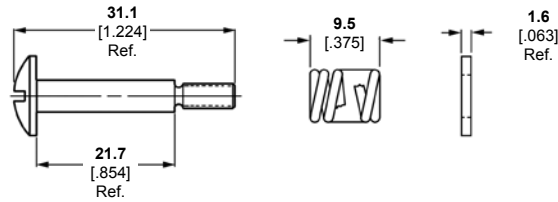

Drawer Connector Specifications

4 Position Housings

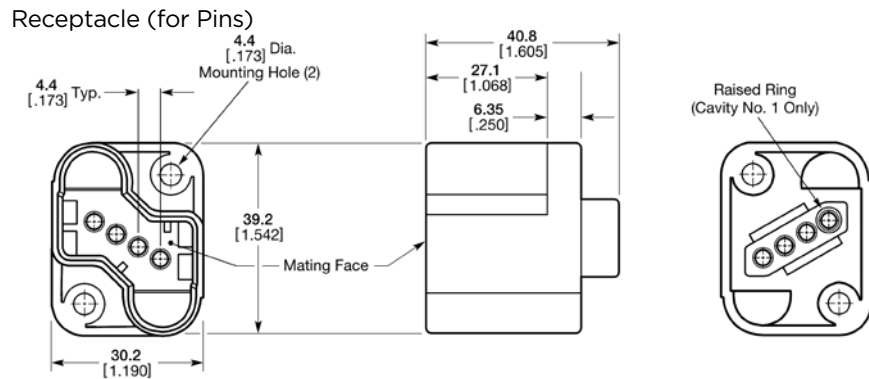
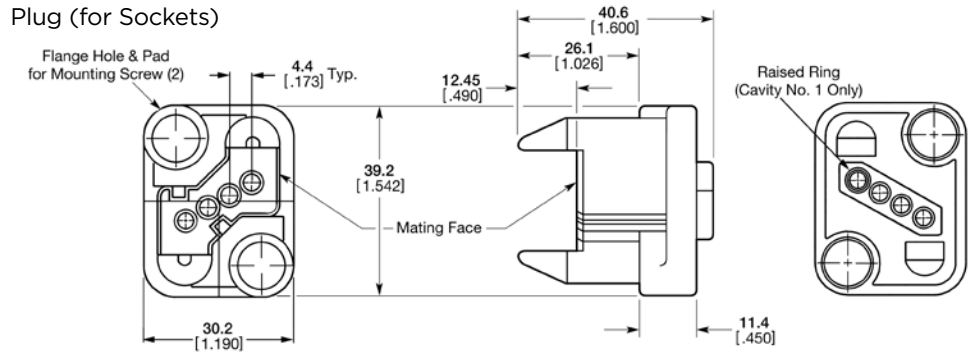

12 Position Housings

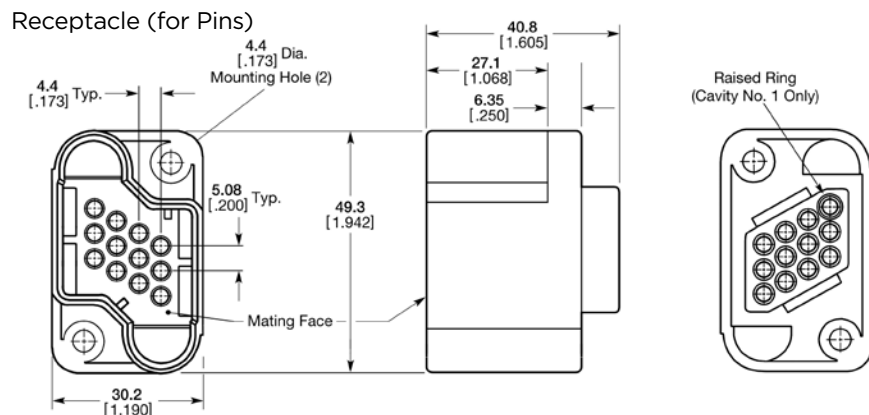
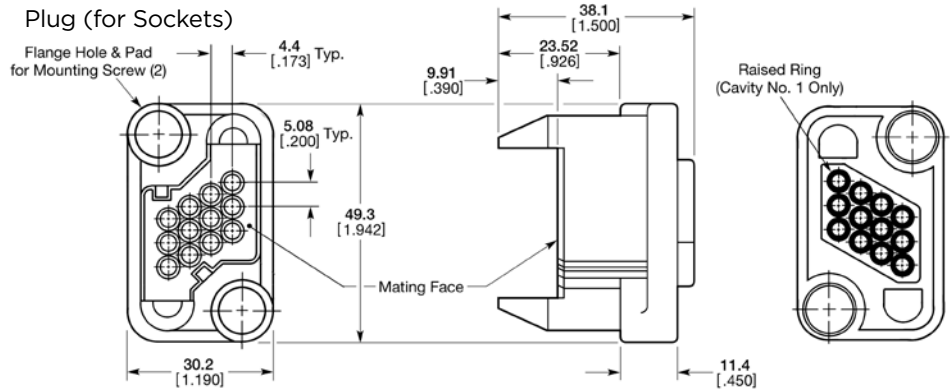

Drawer Connector Specifications (Continued)

19 Position Housings

Plug (for Sockets)

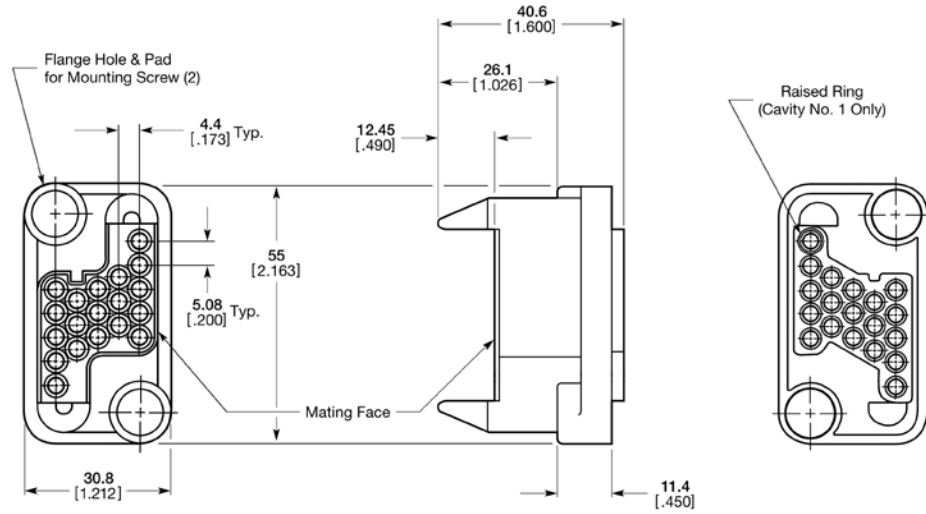

Receptacle (for Pins)

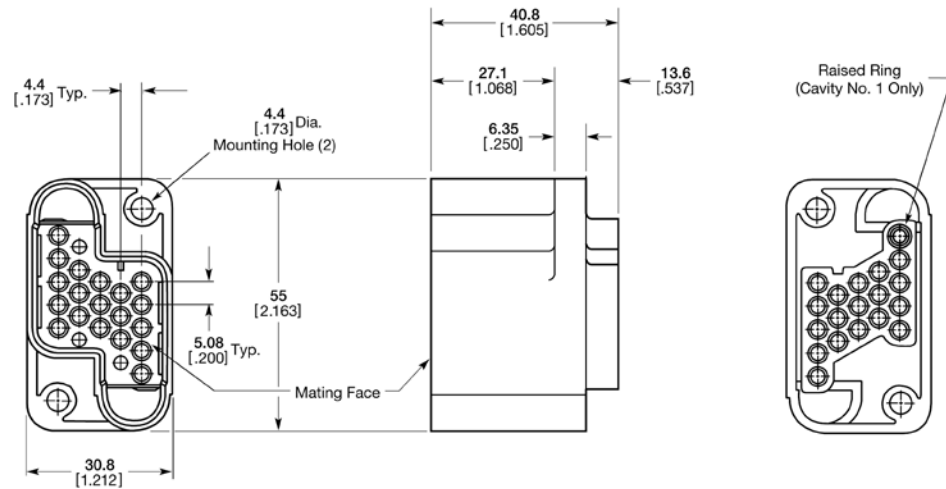

Drawer Connectors

Drawer Connector Specifications (Continued)

25 Position Housings

Plug (for Sockets)

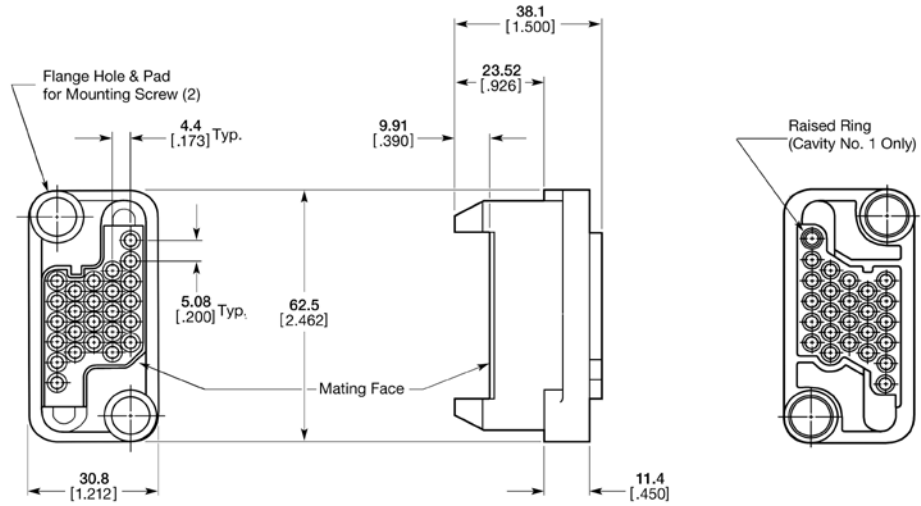

Receptacle (for Pins)

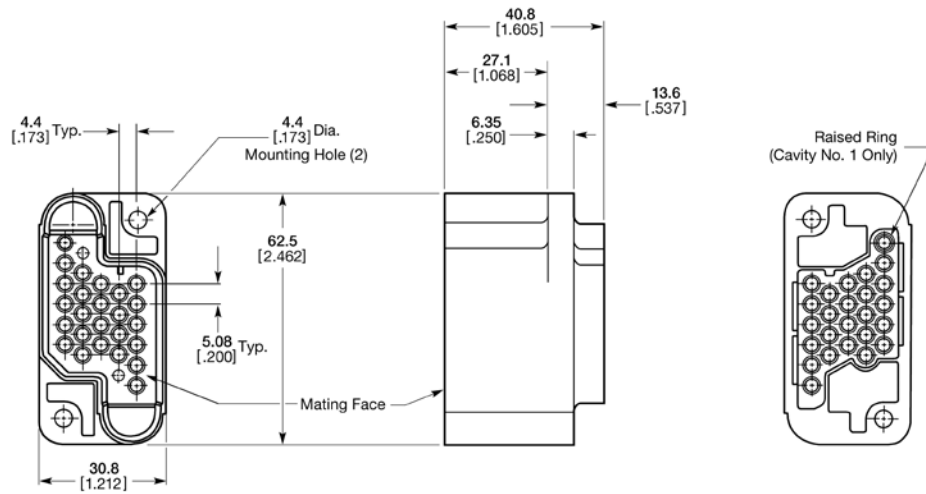

Drawer Connector Specifications (Continued)

**25 Position Headers
(mates with Plug
Connector
Part No. 211150-1)**

Receptacle with ACTION PIN Contacts

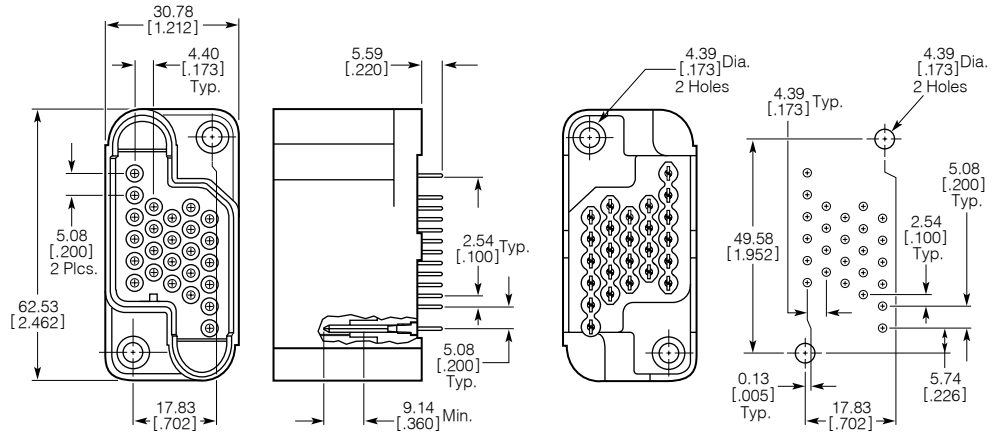

Recommended PC Board Layout

Receptacle (Posted)

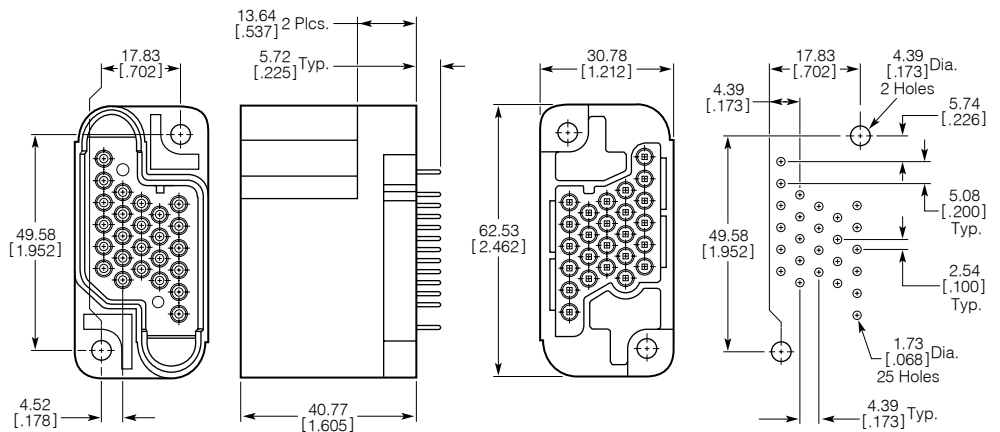

Recommended PC Board Layout

Drawer Connector Specifications (Continued)

**Recommended
Panel Cutouts**

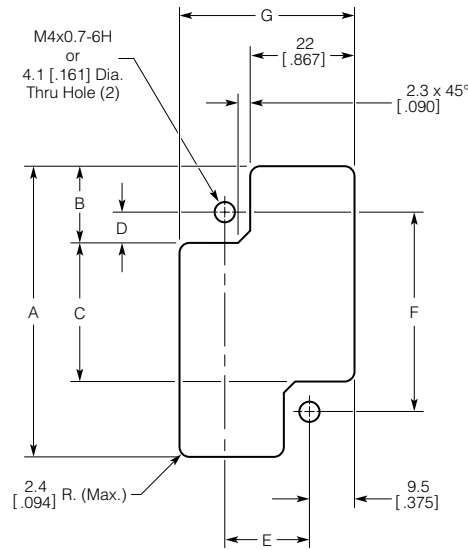

Recommended Panel Cutout
for Plugs (Socket Housings)

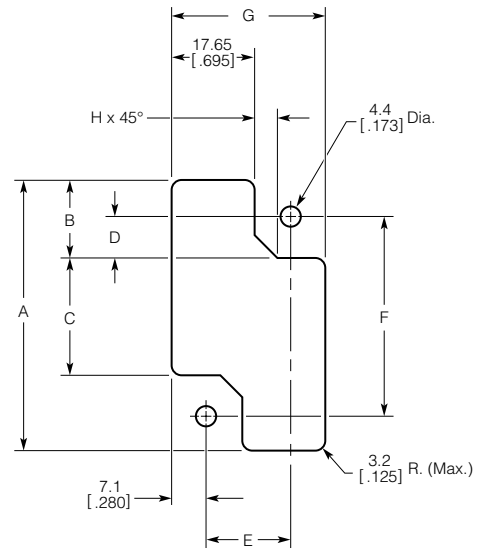

Recommended Panel Cutout
for Receptacles (Pin Housings)

No. of Positions		Dimensions							
		A	B	C	D	E	F	G	H
4	Plug	45.3 1.783	14 .552	17.3 .680	4.5 .176	17.3 .680	26.2 1.032	36.3 1.430	—
	Receptacle	40.5 1.595	13.9 .547	12.8 .502	6.7 .265	17.3 .680	26.2 1.032	31.5 1.240	3.6 .140
12	Plug	55.45 2.183	14 .552	27.4 1.080	4.5 .176	17.3 .680	36.4 1.432	36.3 1.430	—
	Receptacle	50.7 1.995	13.9 .547	22.9 .902	6.7 .265	17.3 .680	36.4 1.432	31.5 1.240	3.6 .140
19, Power Connectors- 8 & 15	Plug	61 2.403	15.9 .626	29.2 1.150	6.4 .251	17.8 .702	42 1.652	36.9 1.452	—
	Receptacle	56.3 2.215	15.93 .627	24.4 .960	8.8 .346	17.8 .702	42 1.652	32 1.262	4.6 .180
25	Plug	68.7 2.703	15.9 .626	36.8 1.450	6.4 .251	17.8 .702	49.6 1.952	36.9 1.452	—
	Receptacle	63.9 2.515	15.93 .627	32 1.260	8.8 .346	17.8 .702	49.6 1.952	32 1.262	4.6 .180

Power Drawer Connector Specifications

8 Position Housings

(Size 8)

Plug (for Sockets)

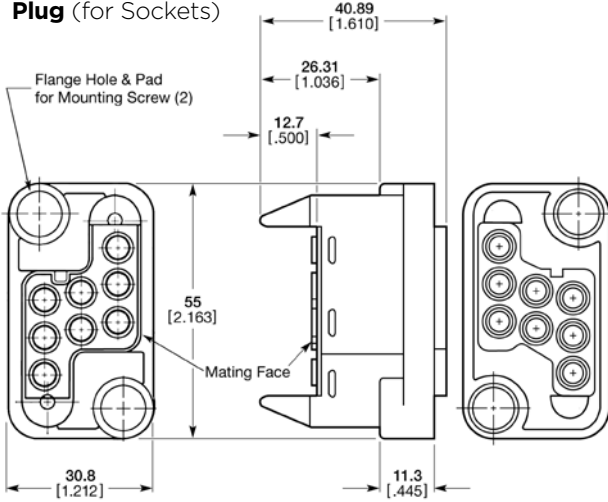

15 Position Housings

(Accept 3 Size 8 Contacts and 12 Size 16 Contacts)

Plug (for Sockets)

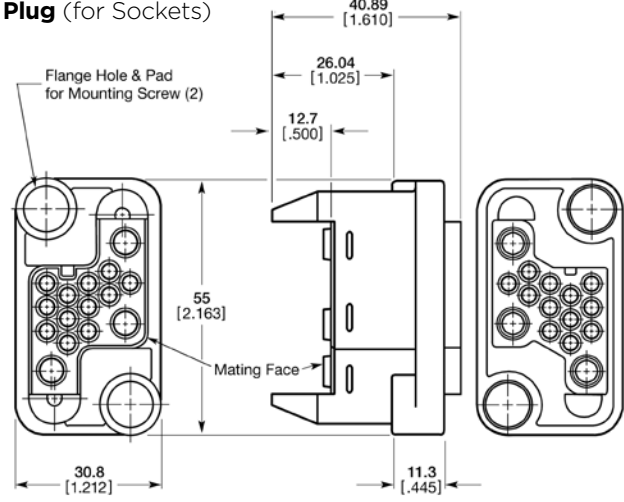

Plug

(for POWERBAND Sockets)

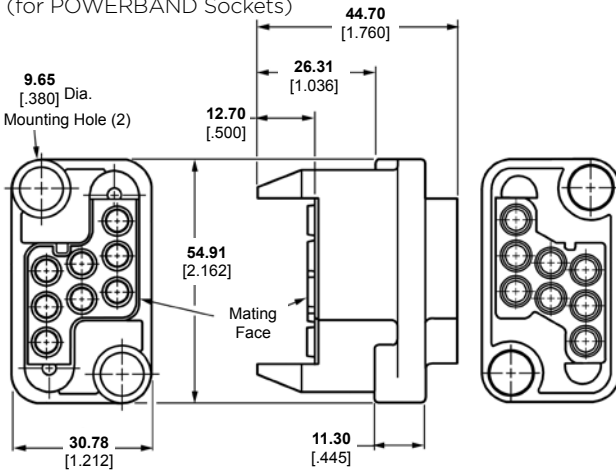

Receptacle (for Pins)

(Size 8 or POWERBAND Pins)

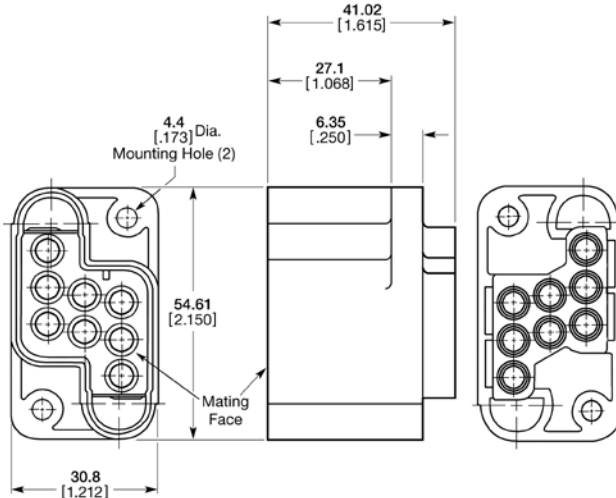

Receptacle (for Pins)

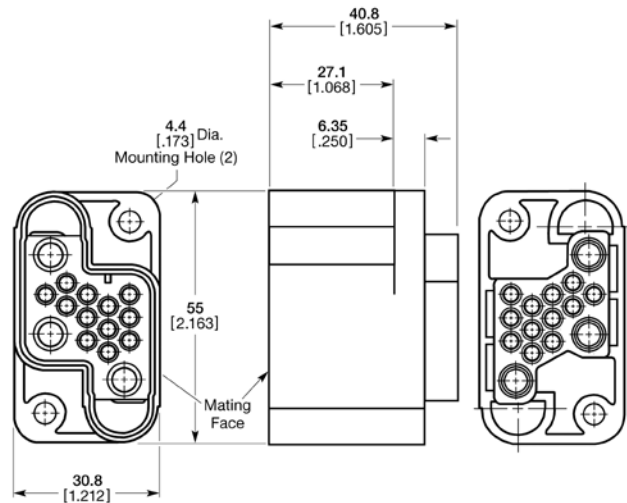

Drawer Connectors

Low Profile Drawer Connectors

18 Position Hybrid Drawer Connector Right-Angle Header Part No. 213942-6

Product Facts

- 13 signal (Type III+)
- Two Size 8 Power—HOT PLUGGABLE! (10 amps AC)
- Three .125 POWERBAND Contacts

No. of Positions	Plug (for sockets)	Receptacle		Page No.
		Header	Housing	
23	213766-1	213768-4	—	29
30	213973-1	—	213974-1	30
18*	213940-1	213942-6	—	27, 28

*5 power, 13 signal

Material and Finish

Housing - Black glass-filled thermoplastic, 94V-0 rated

Contacts - Copper alloy duplex plated 0.00076 [.000030] min. gold on mating end, tin on termination end, with entire contact nickel underplated

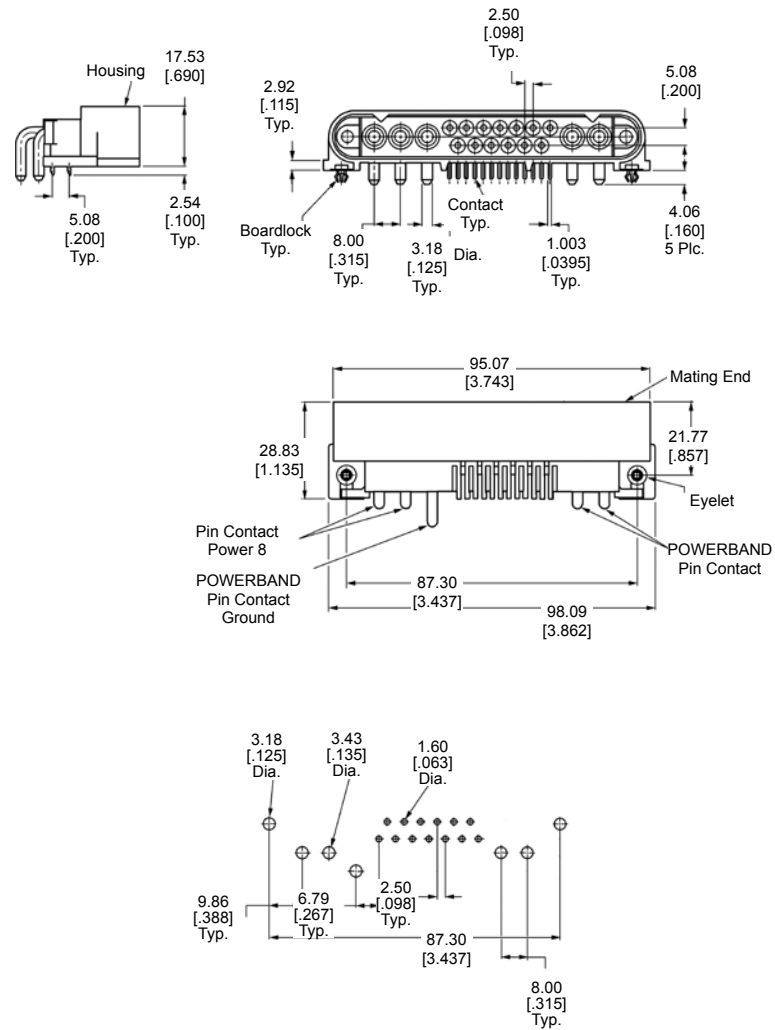

Recommended PC Board Layout

Low Profile Drawer Connectors (Continued)

**18 Position Plug Housing
(for Sockets)**
Part No. 213940-1

Material and Finish

Housing - Black glass-filled
thermoplastic, 94V-0 rated

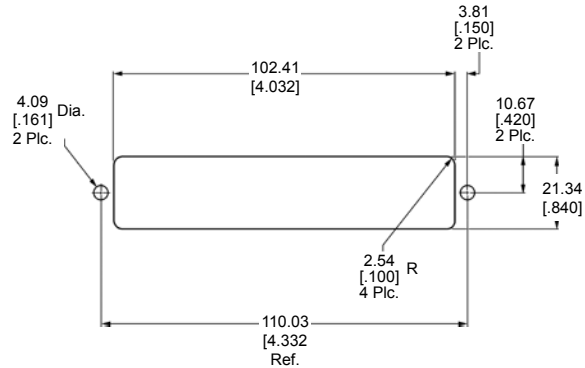
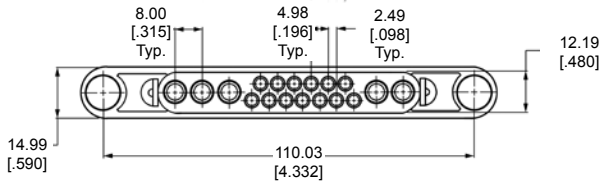
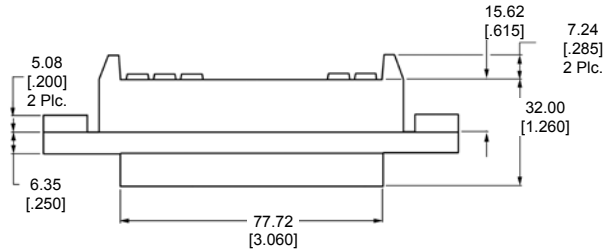
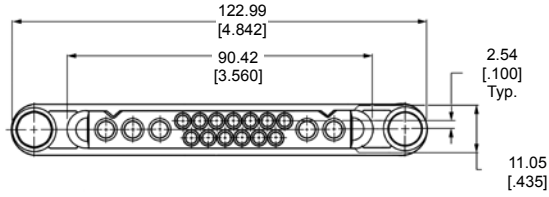

Recommended Panel Cutout

Low Profile Drawer Connectors

Low Profile Drawer Connectors (Continued)

23 Position Plug Housing (for Sockets)
Part No. 213766-1

Material and Finish

Housing - Black glass-filled thermoplastic, 94V-0 rated

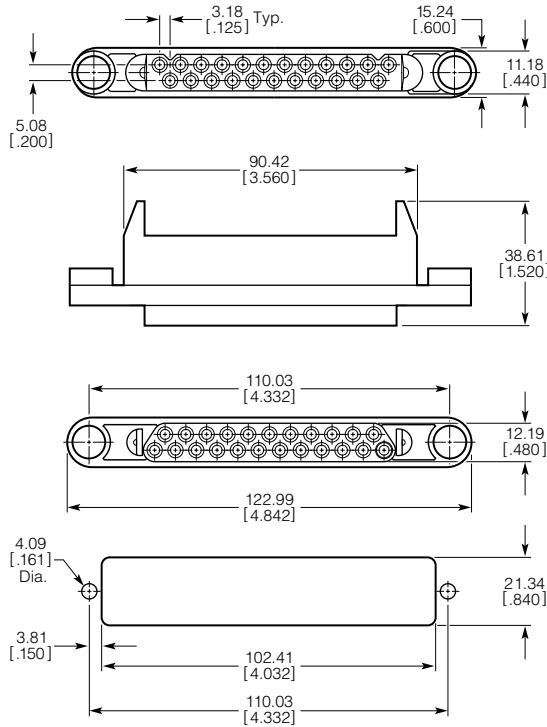

23 Position Receptacle Header
Part No. 213768-4

Material and Finish

Housing - Black glass-filled thermoplastic, 94V-0 rated

Contacts - Copper alloy duplex plated 0.00076 [0.00030] min. gold on mating end, tin-lead on termination end, with entire contact nickel underplated

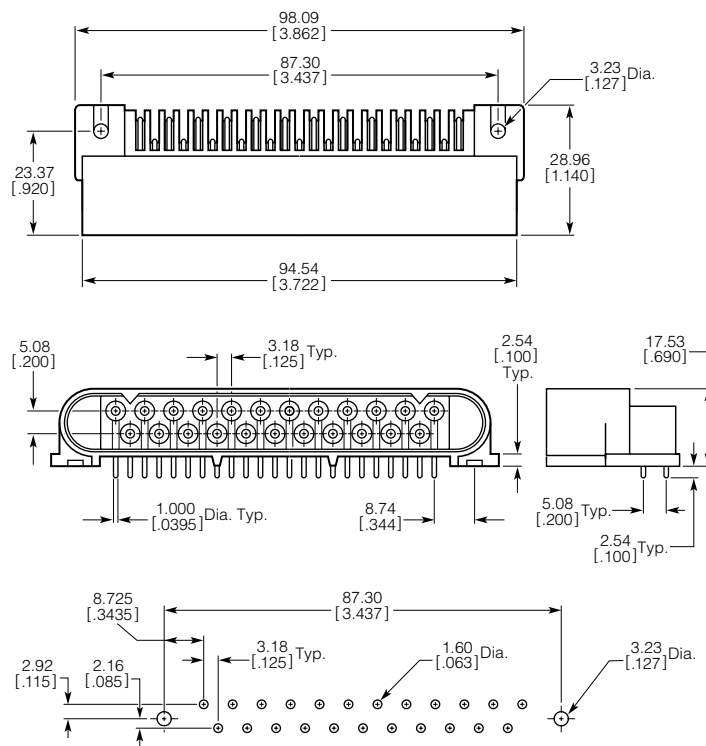

Recommended PC Board Layout

Low Profile Drawer Connectors (Continued)

**30 Position Plug Housing
(for Sockets)**
Part No. 213973-1

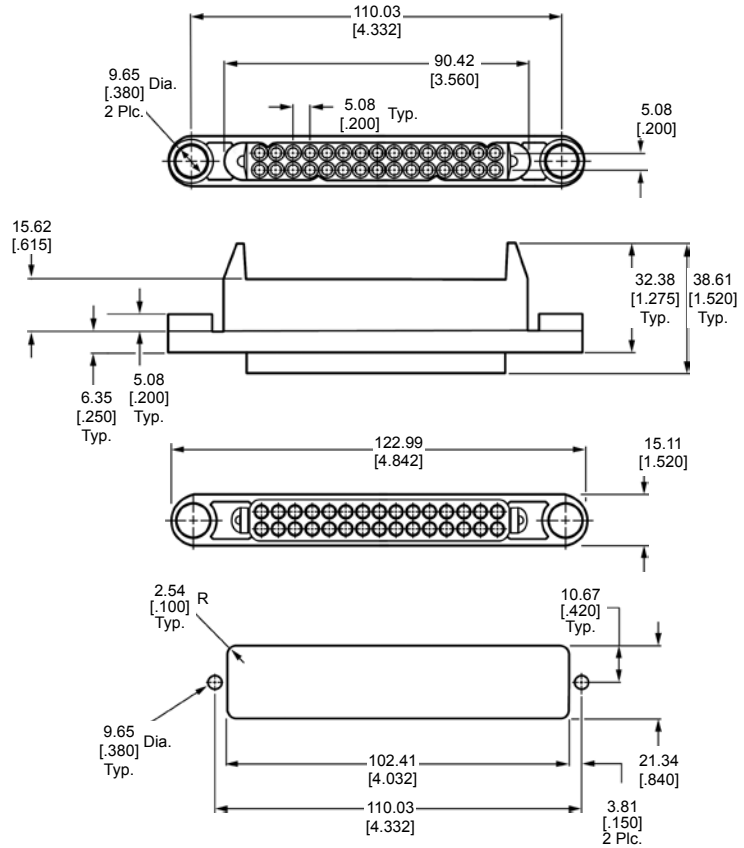

**30 Position Receptacle
Housing (for Pins)**
Part No. 213974-1

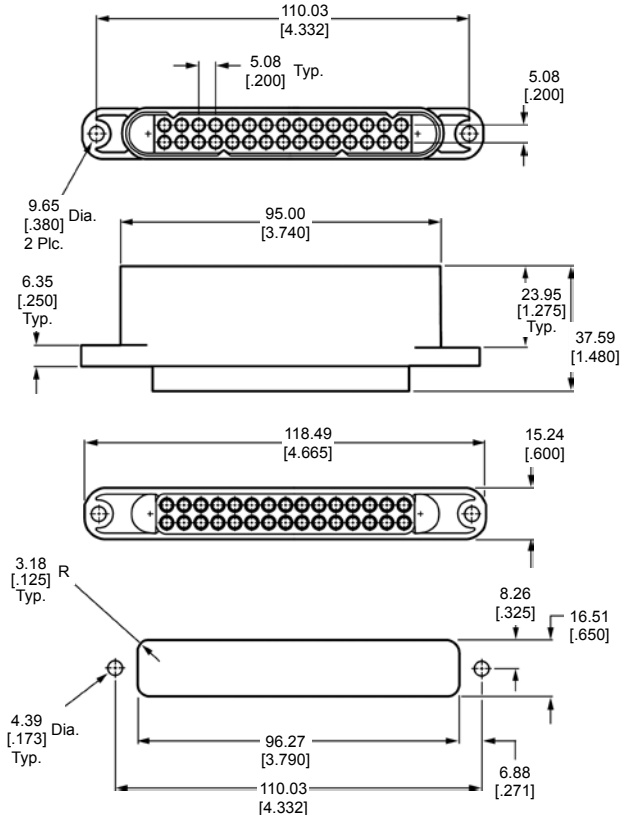

Square Grid Connectors

Free-Hanging and Panel Mount Connectors

Material

Red thermoplastic, 94V-0 rated

Related Product Data

Mateable PC Board Headers -
page 34

Contacts - Pages 9-14

Keying Plug - Page 44

Strain Relief Kits - See below

**Dimensional Specifications
and Recommended Panel
Cutout** - Pages 32 and 33

Performance Characteristics -
Page 3

Technical Documents - Page 58

Product Specification -
108-10033

Application Specification -
114-10040

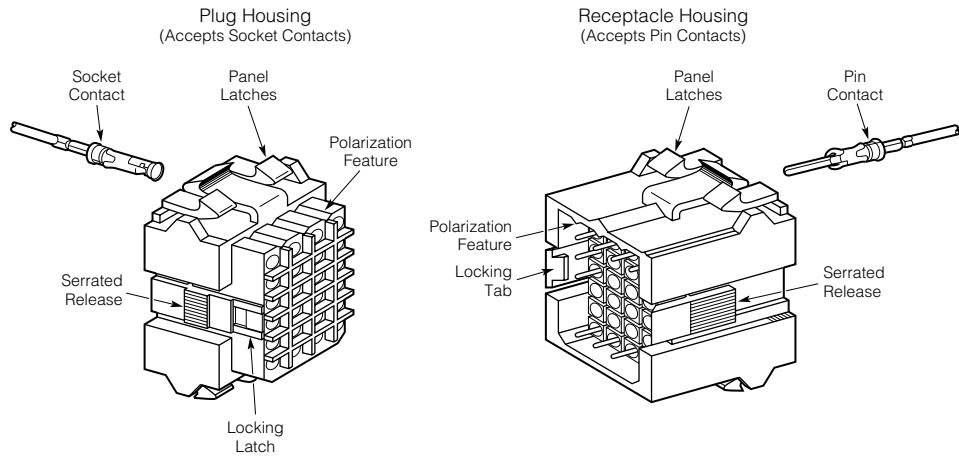

No. of Positions	Housing Part No.*	
	Plug	Receptacle
4	207015-1	207016-1
6	207152-1	207153-1
9	207439-1	207440-1
12	207017-1	207018-1
18	207442-1	207443-1
24	207304-1	207305-1
36	207019-1	207020-1

*Housing only, order contacts separately. See pages 9-14 for contact specifications.

Strain Relief Kits

(For use with plugs and/or receptacles)

Material

Red thermoplastic, 94V-0 rated

Related Product Data

Dimensional Specifications -
page 33

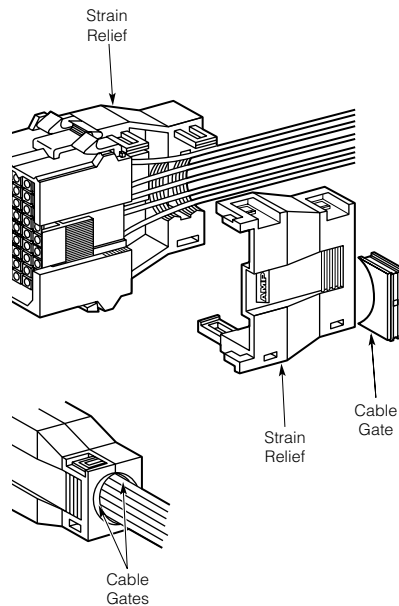

No. of Positions (Connector)	Cable O.D. (Max.)	Strain Relief Kit No.	
		Individual Packs	Bulk Packaging
6	9.5 .375	207600-1	213792-1
9	11.7 .460	207601-1	213793-1
12	13.45 .530	207602-1	—
18	16.5 .650	207603-1	—
24	19.05 .750	207088-1	—
36	23.3 .918	207604-1	213797-1

- Notes:**
1. Cable gates are supplied with each strain relief kit to accommodate various cable diameters up to the maximum specified.
 2. Components for all strain relief kits are packaged unassembled.

Square Grid Connector Specifications

4 and 6 Position Housings

Plug (for Sockets)

Receptacle (for Pins)

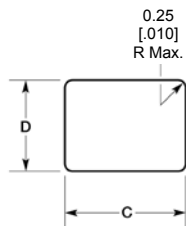
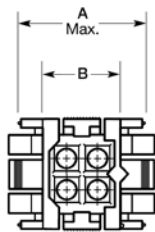
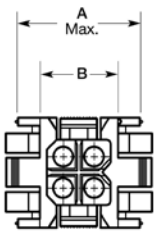
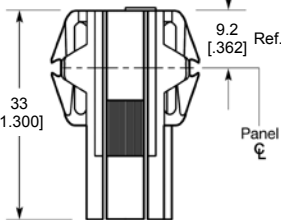
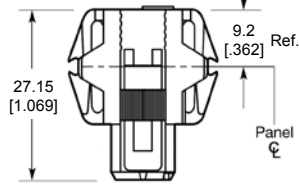
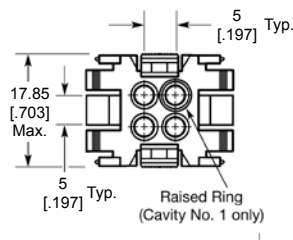
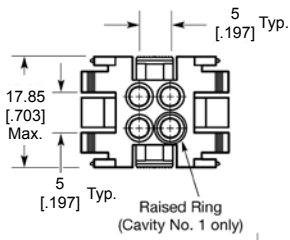

9, 12 and 18 Position Housings

Plug (for Sockets)

Receptacle (for Pins)

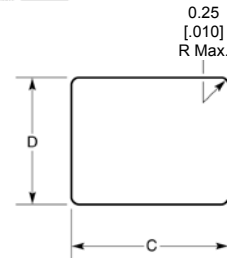
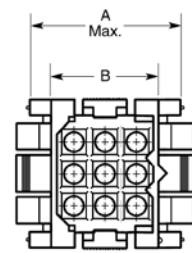
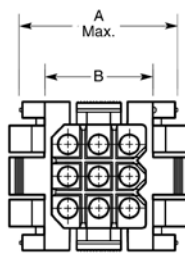
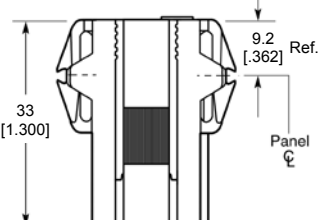
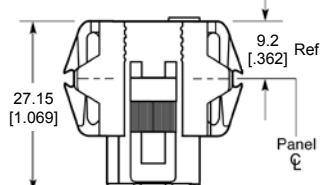
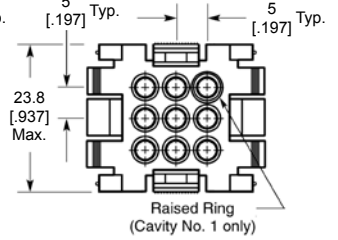
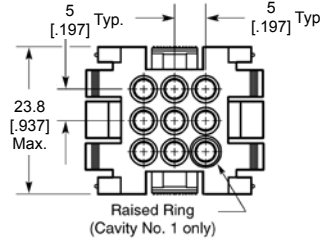

Recommended Panel Cutout
(for Plug or Receptacle)

Recommended Panel Cutout
(for Plug or Receptacle)

No. of Positions	Connector Dimensions		Panel Cutout Dimensions	
	A	B	C	D
4	20.1 .791	12.6 .496	20.57 .810	18.1 .712
6	25.04 .986	17.5 .689	25.35 .998	18.1 .712
9	24.8 .976	17.5 .689	25.35 .998	24 .945
12	29.8 1.173	22.5 .886	30.23 1.190	24 .945
18	40.45 1.592	32.85 1.293	40.77 1.605	24 .945

Note: Panel thickness 0.76-2.29 [.030-.090]

Square Grid Connector Specifications (Continued)

24 and 36 Position Housings

Plug (for Sockets)

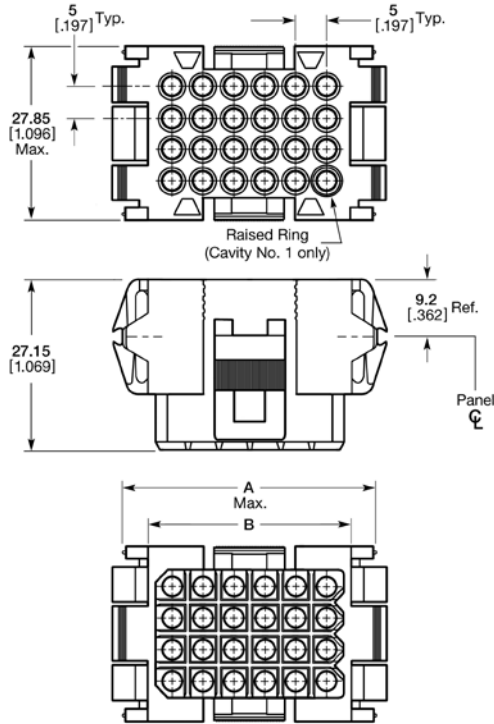

Receptacle (for Pins)

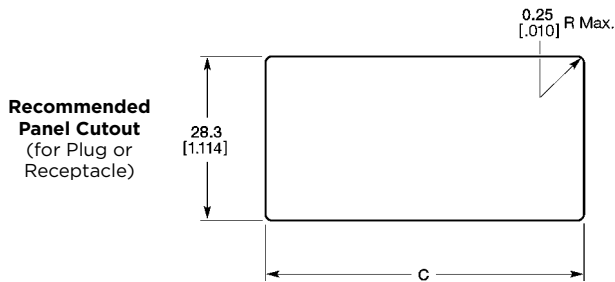
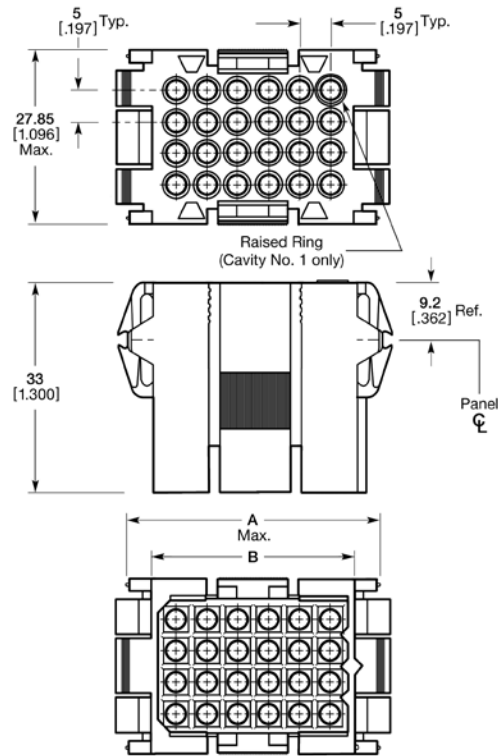

No. of Positions	Connector Dimensions		Panel Cutout Dimensions C
	A	B	
24	40.45 1.592	32.85 1.293	40.77 1.605
36	55.45 2.183	47.85 1.885	55.75 2.195

Note: Panel thickness 0.76-2.29 [.030-.090]

Strain Relief Kits (for 6, 9, 12, 18, 24 and 36 Position Connectors)

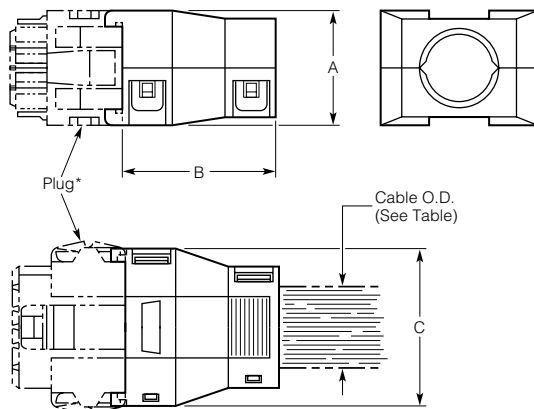

No. of Positions	Dimensions			Cable O.D. (Max.)
	A	B	C	
6	17.75 .700	25.53 1.005	22.75 .896	9.5 .375
9	23.9 .940	32.4 1.275	22.75 .896	11.7 .460
12	23.9 .940	32.4 1.275	27.58 1.086	13.45 .530
18	23.9 .940	38.1 1.500	38.1 1.500	16.5 .650
24	27.94 1.100	38.1 1.500	38.1 1.500	19.05 .750
36	27.94 1.100	38.1 1.500	53.1 2.090	23.3 .918

*Plug shown for illustration purposes only. Strain Relief Kits can be used on either plug or receptacle.

Square Grid Connectors

PC Board Mount Headers

Material and Finish

Housing - Red thermoplastic, 94V-0 rated

Pin Contacts - Copper alloy, plated tin or gold duplex

Socket Contacts - Phosphor bronze, plated tin or gold duplex

Related Product Data

Mateable Free-Hanging Connectors - Page 31

(Pin and Socket Headers do not mate.)

Dimensional Specifications and Recommended PC Board Layout - Pages 35-38

Performance Characteristics - Page 3

Technical Documents - Page 58

Product Specification - 108-10033

Application Specification - 114-10040

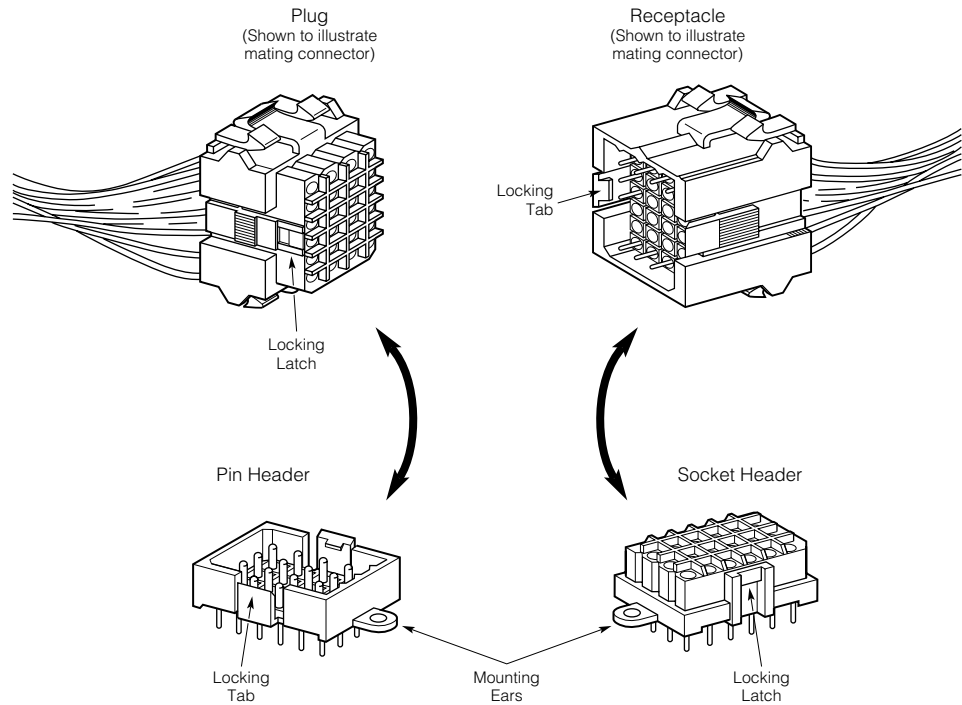

No. of Positions	Contact Plating	Pin Header Part No.		Mates with Plug Part No. (Page 31)	Socket Header Part No.		Mates with Receptacle Part No. (Page 31)
		With Mounting Ears	Without Mounting Ears		With Mounting Ears	Without Mounting Ears	
4	Tin	207119-8	207119-9	207015-1	207496-7	207496-8	207016-1
	Gold*	1-207119-0	1-207119-1		207496-9	1-207496-0	
6	Tin	207158-7	207158-8	207152-1	207524-7	207524-8	207153-1
	Gold*	1-207158-0	1-207158-1		207524-9	1-207524-0	
9	Tin	207441-7	207441-8	207439-1	207526-7	207526-8	207440-1
	Gold*	1-207441-0	207441-9		207526-9	1-207526-4	
12	Tin	207120-9	1-207120-0	207017-1	207528-7	207528-8	207018-1
	Gold*	207120-8	1-207120-1		207528-9	1-207528-0	
18	Tin	207444-9	1-207444-0	207442-1	207530-7	207530-8	207443-1
	Gold*	207444-8	1-207444-1		207530-9	1-207530-0	
24	Tin	1-206763-1	1-206763-2	207304-1	207532-8	207532-9	207305-1
	Gold*	1-206763-3	1-206763-4		1-207532-0	1-207532-1	
36	Tin	207121-8	—	207019-1	207534-8	207534-9	207020-1
	Gold*	207121-9	1-207121-0		1-207534-0	1-207534-1	

*Duplex plated 0.00076 [0.00030] gold on mating end, tin on termination end, with entire contact nickel underplated.

Note: Pin and Socket Headers do not mate.

Square Grid Pin Header Specifications

4 and 6 Position Headers

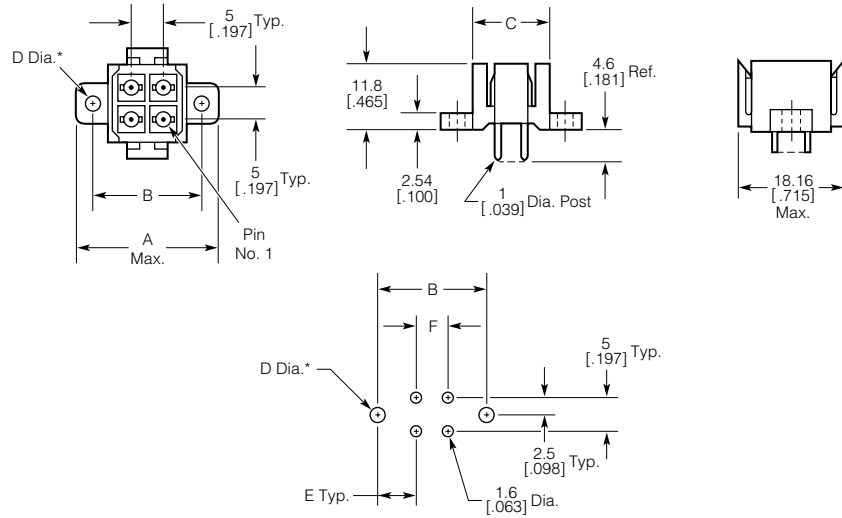

Recommended PC Board Layout

9, 12 and 18 Position Headers

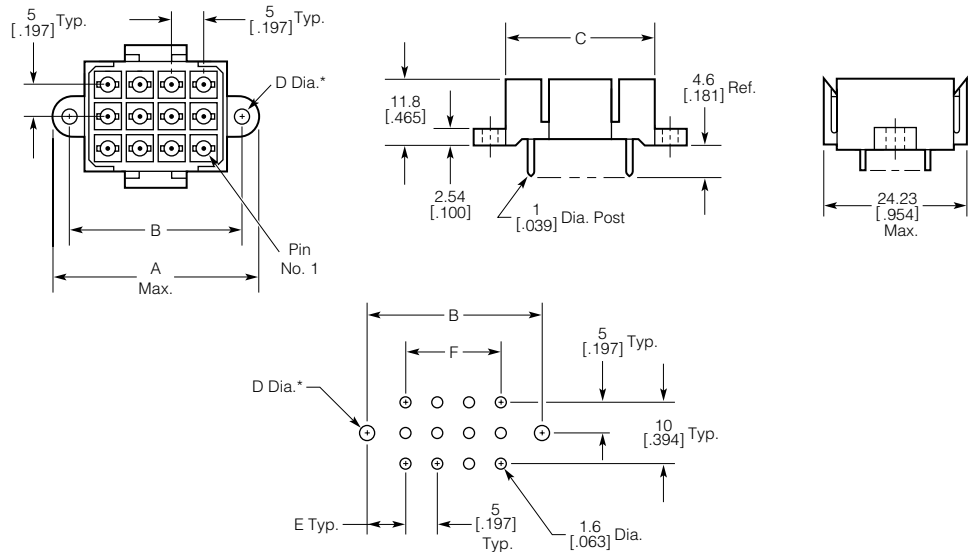

Recommended PC Board Layout

No. of Positions	Header Dimensions				PC Board Layout Dimensions			
	A	B	C	D*	B	D*	E	F
4	22.61 .890	17.4 .685	12.7 .500	2.65 .104	17.4 .685	2.65 .104	6.2 .244	5 .197
6	27.69 1.090	22.4 .882	17.6 .693	2.65 .104	22.4 .882	2.65 .104	6.2 .244	10 .394
9	27.69 1.090	22.4 .882	17.78 .700	2.65 .104	22.4 .882	2.65 .104	6.2 .244	10 .394
12	32.5 1.280	27.3 1.075	22.61 .890	2.65 .104	27.3 1.075	2.65 .104	6.2 .244	15 .591
18	47.32 1.863	40.6 1.598	32.85 1.293	3.3 .130	40.6 1.598	3.3 .130	7.8 .307	25 .984

*D Dia.—2.65 [.104] for No. 2 screw; 3.3 [.130] for No. 4 screw.

NOTE: All part numbers
are RoHS Compliant

Square Grid Pin Header Specifications (Continued)

**24 and 36 Position
Headers**

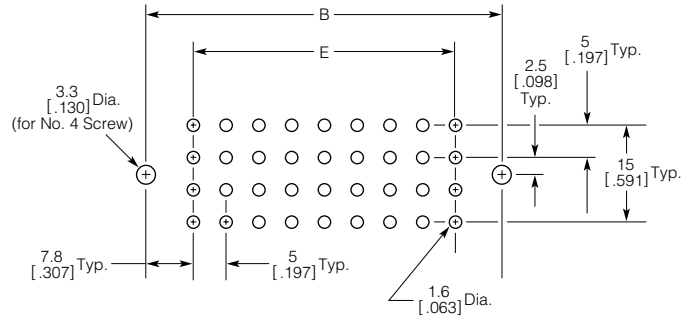
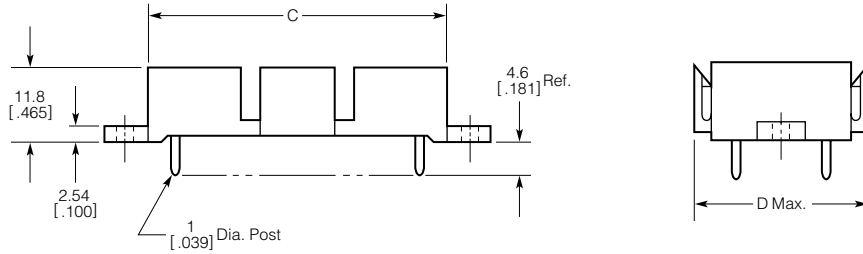
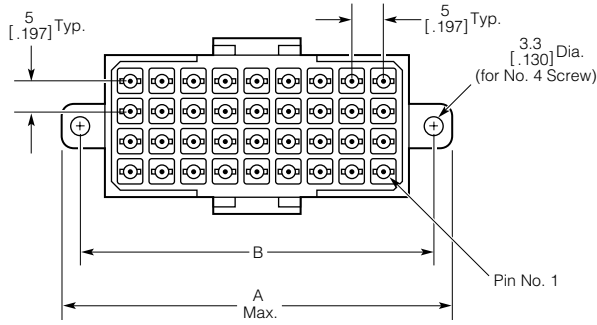

Recommended PC Board Layout

No. of Positions	Header Dimensions				PC Board Layout Dimensions	
	A	B	C	D	B	E
24	47.32 1.863	40.6 1.598	32.85 1.293	29.36 1.156	40.6 1.598	25 .984
36	62.31 2.453	55.58 2.188	48.01 1.890	29.87 1.176	55.58 2.188	40 1.575

Square Grid Socket Header Specifications

4 and 6 Position Headers

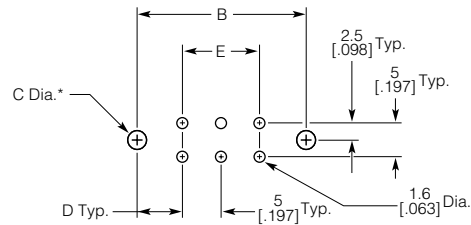
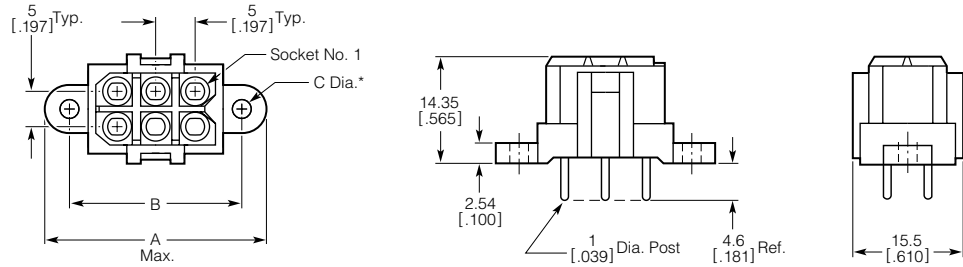

Recommended PC Board Layout

9, 12 and 18 Position Headers

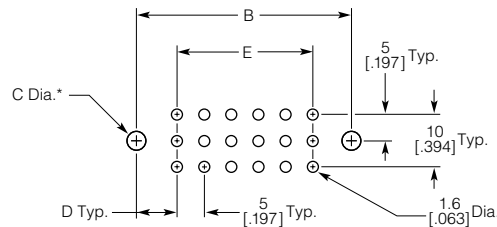
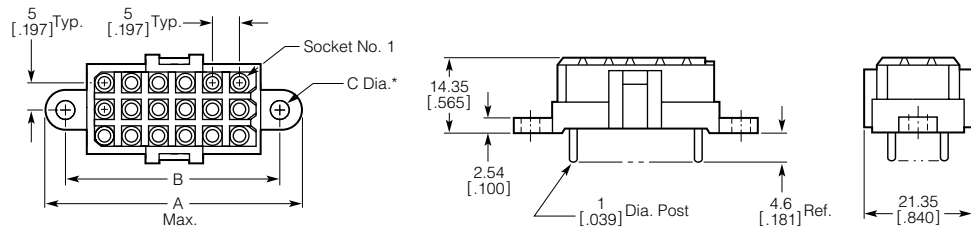

Recommended PC Board Layout

No. of Positions	Header Dimensions			PC Board Layout Dimensions			
	A	B	C*	B	C*	D	E
4	22.61 .890	17.4 .685	2.65 .104	17.4 .685	2.65 .104	6.2 .244	5 .197
6	27.69 1.090	22.4 .882	2.65 .104	22.4 .882	2.65 .104	6.2 .244	10 .394
9	27.69 1.090	22.4 .882	2.65 .104	22.4 .882	2.65 .104	6.2 .244	10 .394
12	32.5 1.280	27.3 1.075	2.65 .104	27.3 1.075	2.65 .104	6.2 .244	15 .591
18	47.32 1.863	40.6 1.598	3.3 .130	40.6 1.598	3.3 .130	7.8 .307	25 .984

*C Dia.—2.65 [.104] for No. 2 screw; 3.3 [.130] for No. 4 screw.

NOTE: All part numbers are RoHS Compliant

Square Grid Pin Header Specifications (Continued)

24 and 36 Position Headers

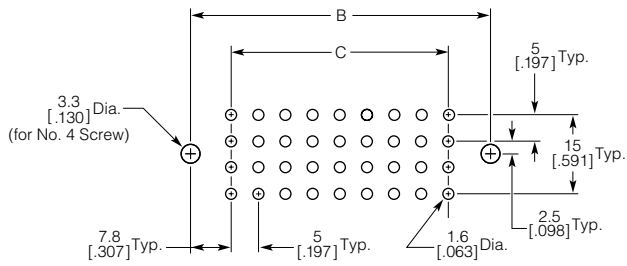
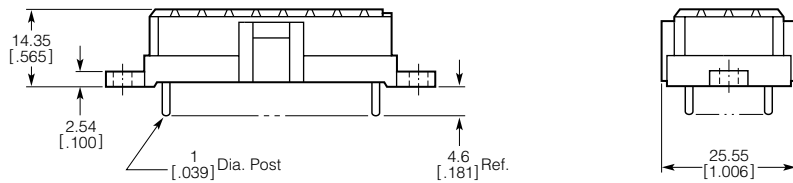
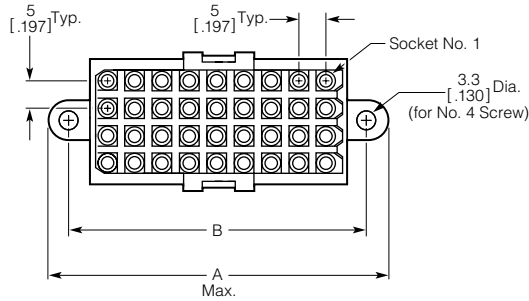

Recommended PC Board Layout

No. of Positions	Header Dimensions		PC Board Layout Dimensions	
	A	B	B	C
24	47.32 1.863	40.6 1.598	40.6 1.598	25 .984
36	62.31 2.453	55.58 2.188	55.58 2.188	40 1.575

In-Line Connectors, 5 [.197] Centerline

Free-Hanging Connectors

Material

Red thermoplastic, 94V-0 rated

Related Product Data

Mateable PC Board Mount Headers - Pages 41 and 48-51

Contacts - Pages 9-14

Keying Plug - Page 44

Dimensional Specifications - Page 40

Performance Characteristics - Page 3

Technical Documents - Page 58

Product Specification - 108-10033

Application Specification - 114-10040

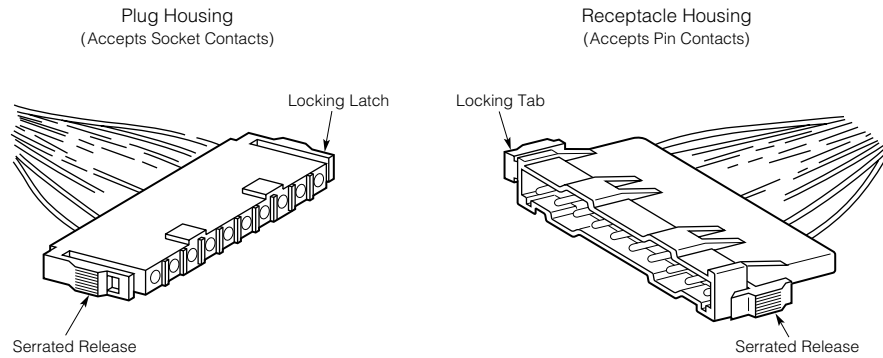

No. of Positions	Housing Part No.*	
	Plug	Receptacle
1 (Positive Latch)	207535-1**	207535-1**
1 (Breakaway Latch)	211076-1**	211076-1**
3	207360-1	207359-1
6	207377-1	207376-1
10	207396-1	207397-1
16	207542-1	207543-1

*Housing only, order contacts separately. See pages 9-14 for contact specifications.

**Hermaphroditic housing accepts pins or sockets and mates with itself.

Note: 1-Position Housings with Positive Latch NOT designed to be unmated; Breakaway Latch designed to be unmated.

1 position Housing (Breakaway Latch shown)

(Hermaphroditic Housing Accepts Pins or Sockets and Mates With Itself.)

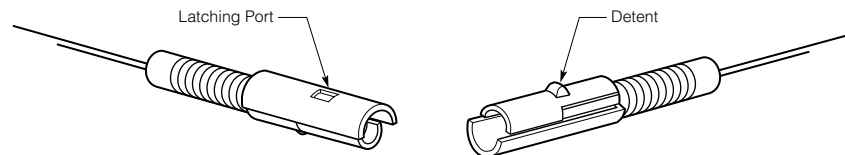

In-Line Connector Specifications, 5 [.197] Centerline

Single Position Hermaphroditic Housings

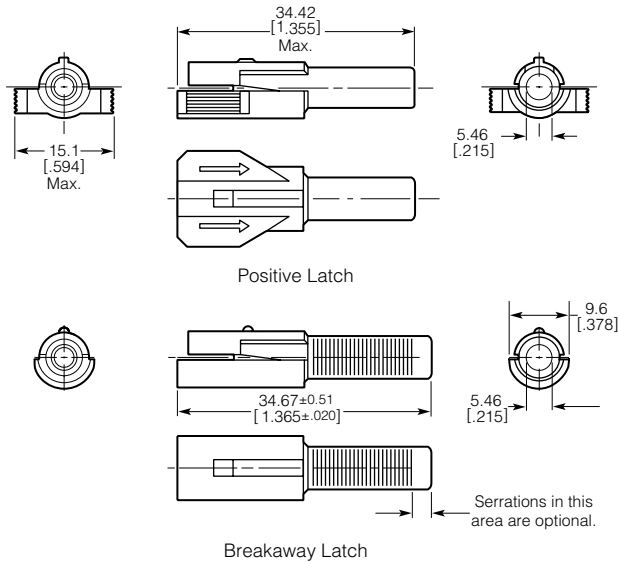

**6, 10 and 16 Position Housings
Plug (for Sockets)**

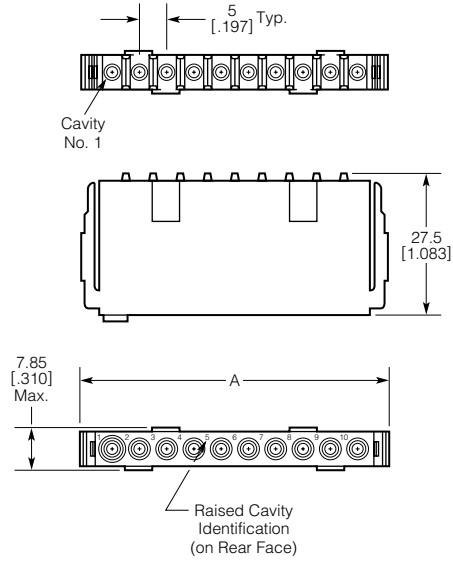

**3 Position Housings
Plug (for Sockets)**

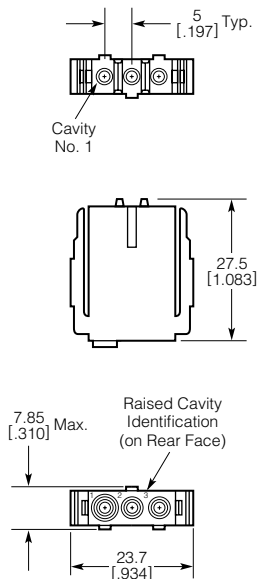

Receptacle (for Pins)

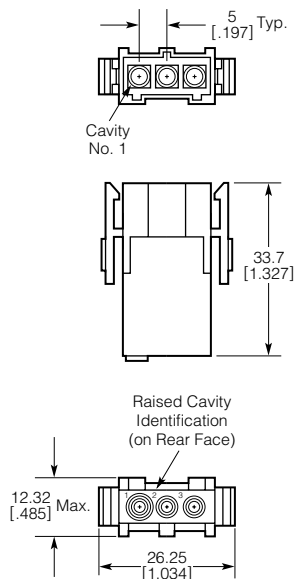

Receptacle (for Pins)

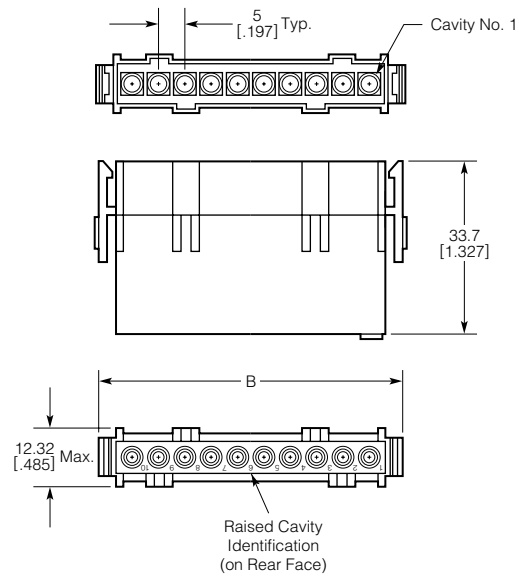

No. of Positions	Dimensions	
	A	B
6	38.7 1.524	41.3 1.625
10	58.7 2.312	61.3 2.413
16	89.79* 3.535	91.19 3.59

*A Dim. is Max. for 16-position housing.

In-Line Connectors, 5 [.197] Centerline

PC Board Mount Headers

Material and Finish

Housing - Red thermoplastic, 94V-0 rated

Pin Contacts - Copper alloy, plated tin or gold duplex

Socket Contacts - Phosphor bronze, plated tin or gold duplex

Related Product Data

Mateable Free-Hanging Connectors - Page 39 (Pin and Socket Headers do not mate.)

Dimensional Specifications and Recommended PC Board Layout - Pages 42, 43

Performance Characteristics - Page 3

Technical Documents - Page 58
Product Specification - 108-10033

Application Specification - 114-10040



No. of Positions	Contact Plating	Pin Header Part No.		Mates with Plug Part No. (Page 39)
		Straight-Thru	Right-Angle	
3	Tin	207365-7	207541-6	207360-1
	Gold*	207365-8	207541-7	
6	Tin	207583-6	207378-6	207377-1
	Gold*	207583-7	207378-7	
10	Tin	207584-7	207398-6	207396-1
	Gold*	207584-8	207398-7	
16	Tin	207599-6	207544-8	207542-1
	Gold*	207599-7	207544-7	

*Duplex plated 0.00076 [.000030] gold on mating end, tin on termination end, with entire contact nickel underplated.

Note: Pin and Socket Headers do not mate.



No. of Positions	Contact Plating	Socket Header Part No.		Mates with Receptacle Part No. (Page 39)
		Straight-Thru	Right-Angle	
3	Tin	207609-6	207608-6	207359-1
	Gold*	207609-7	207608-7	
6	Tin	207611-6	207610-6	207376-1
	Gold*	207611-7	207610-7	
10	Tin	207613-6	207612-6	207397-1
	Gold*	207613-7	207612-7	
16	Tin	207615-6	207614-6	207543-1
	Gold*	207615-7	207614-7	

*Duplex plated 0.00076 [.000030] gold on mating end, tin on termination end, with entire contact nickel underplated.

Note: Pin and Socket Headers do not mate.

In-Line Pin Header Specifications, 5 [.197] Centerline

Straight-Thru

3 Position Header

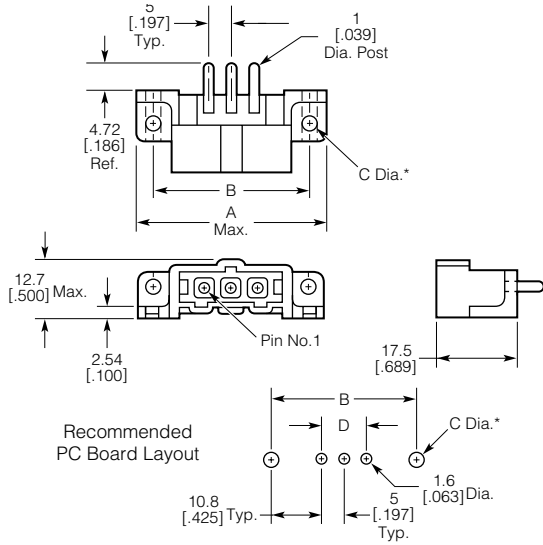

Right-Angle

3 Position Header

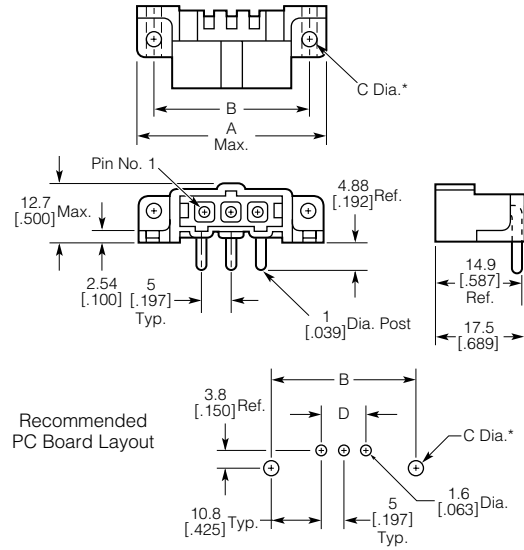

6, 10 and 16 Position Headers

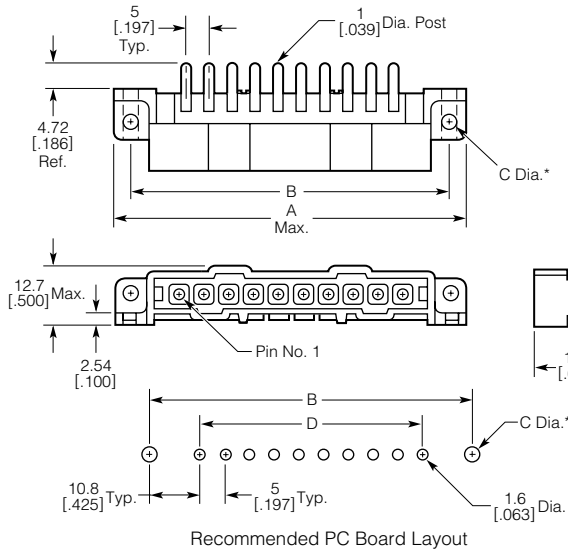

6, 10 and 16 Position Headers

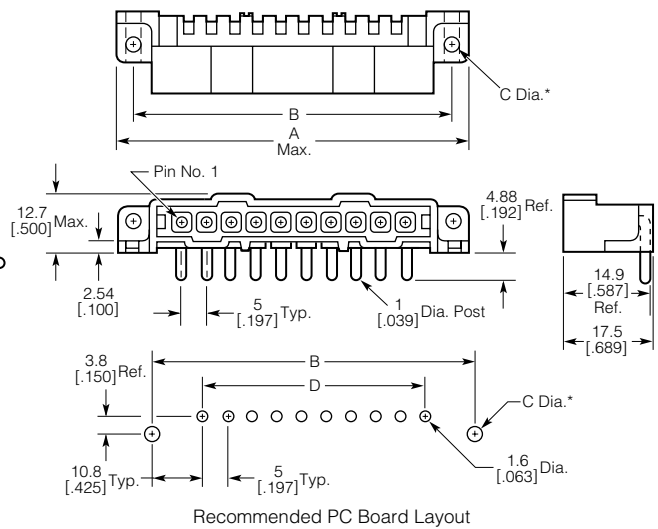

No. of Positions	Header Dimensions			PC Board Layout Dimensions		
	A	B	C*	B	C*	D
3	36.86 1.451	31.6 1.244	2.65 .104	31.6 1.244	2.65 .104	10 .394
6	51.87 2.042	46.6 1.834	2.65 .104	46.6 1.834	2.65 .104	25 .984
10	71.86 2.829	66.6 2.622	2.85 .112	66.6 2.622	2.85 .112	45 1.772
16	102.64 4.041	96.6 3.803	2.85 .112	96.6 3.803	2.85 .112	75 2.953

*C Dia.—2.65 [.104] for No. 2 screw; 2.85 [.112] for No. 3 screw.

In-Line Socket Header, 5 [.197] Centerline

Straight-Thru

3 Position Header

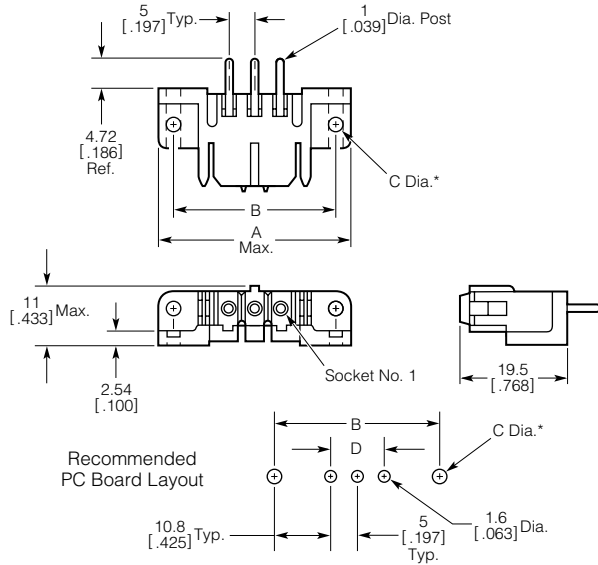

Right-Angle

3 Position Header

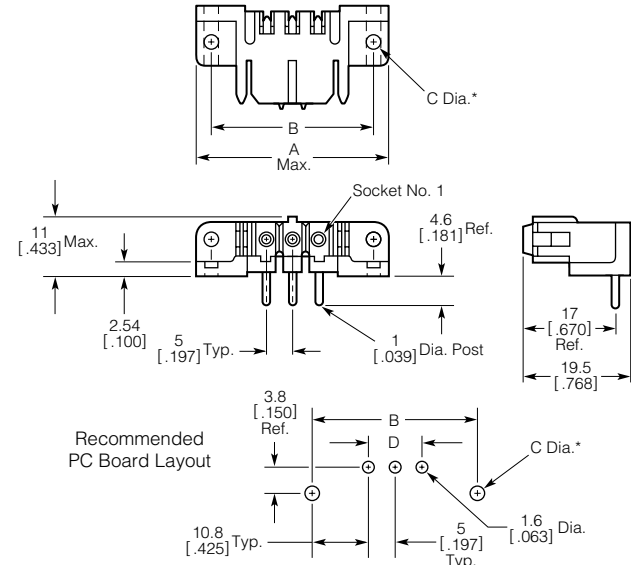

6, 10 and 16 Position Headers

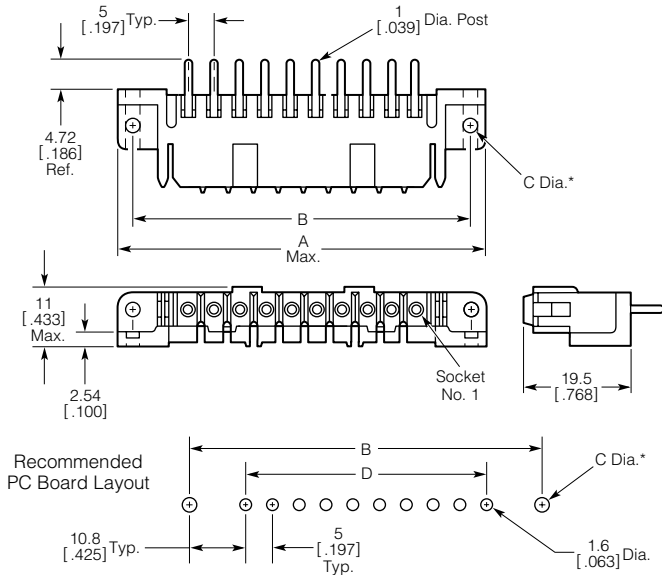

6, 10 and 16 Position Headers

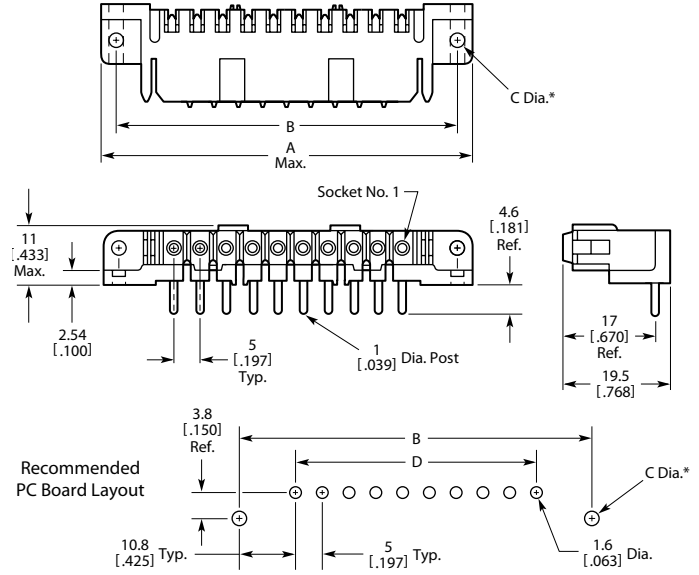

No. of Positions	Header Dimensions			PC Board Layout Dimensions		
	A	B	C*	B	C*	D
3	36.55 1.439	31.6 1.244	2.65 .104	31.6 1.244	2.65 .104	10 .394
6	51.59 2.031	46.6 1.834	2.65 .104	46.6 1.834	2.65 .104	25 .984
10	71.6 2.819	66.6 2.622	2.85 .112	66.6 2.622	2.85 .112	45 1.772
16	101.78 4.007	96.6 3.803	2.85 .112	96.6 3.803	2.85 .112	75 2.953

*C Dia.—2.65 [.104] for No. 2 screw; 2.85 [.112] for No. 3 screw.

In-Line Connectors, 5.08 [.200] Centerline

Free-Hanging Connector and PC Board Mount Pin Header

Material and Finish

Connector

Red thermoplastic, 94V-0 rated

Header

Housing - Red thermoplastic, 94V-0 rated

Contact - Copper alloy, plated tin or gold duplex

Plug Housing
(Accepts Socket Contacts)

Right-Angle
Pin Header

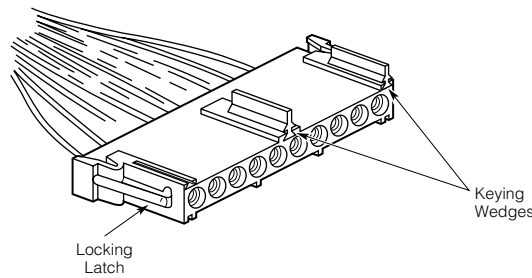

Related Product Data

Contacts - Pages 9-14

Keying Plug - See Below

Dimensional Specifications and Recommended PC Board Layout - Pages 45-47

Performance Characteristics - Page 3

Technical Documents - Page 58

No. of Positions	In-Line Connector Plug Part No.*	Right-Angle Pin Header		
		Contact Plating	Standard Part No.	Keyed Part No.
6	208117-1	Tin	208116-4***	—
10	208404-1	Tin	3-208403-2	3-208403-3 ¹ , 3-208403-4 ²
19	208100-1	Tin	208099-3	—
		Gold**	212630-4	—

*Housing only, order contacts separately. See pages 9-14 for contact specifications.

**Duplex plated 0.00076 [.00030] gold on mating end, tin on termination end, with entire contact nickel underplated.

***Longer tail version also available, P/N 208116-5.

¹Location A knocked out.

²Location B knocked out.

Keying Wedge Part No. 208400-1

(for use with In-Line Plug Connectors, above)

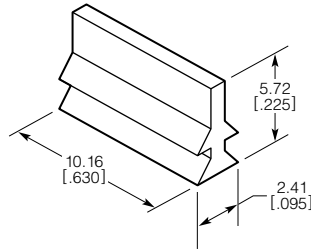

Keying Plugs

Keying Plugs

(for use with all types)

Material

Nylon

Related Product Data

Used with:

Square Grid Connectors - Pages 31-34

In-Line Connectors - Pages 39-41

Drawer Connectors - Pages 18, 19

For Plug Housings

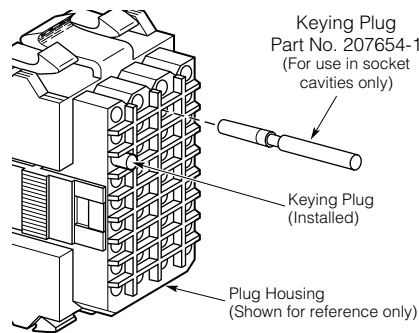

For Socket Headers

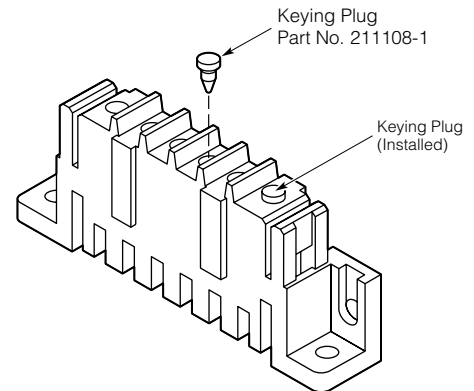

In-Line Connector Specifications, 5.08 [.200] Centerline

6 Position Plug Housing (for Sockets)

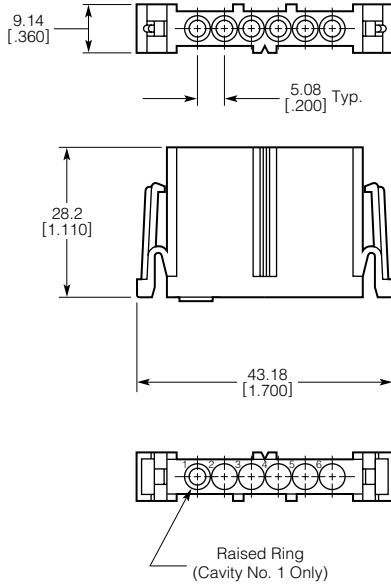

10 Position Plug Housing (for Sockets)



19 Position Plug Housing (for Sockets)



In-Line Right-Angle Pin Header Specifications, 5.08 [.200] Centerline

6 Position Header

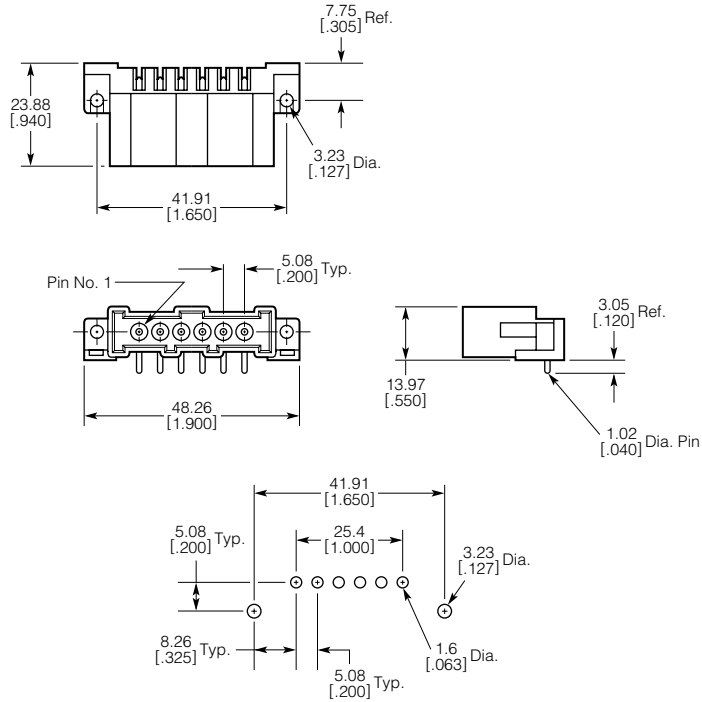

Recommended PC Board Layout

10 Position Header



Recommended PC Board Layout

In-Line Right-Angle Pin Header Specifications,
5.08 [.200] Centerline (Continued)

19 Position Header

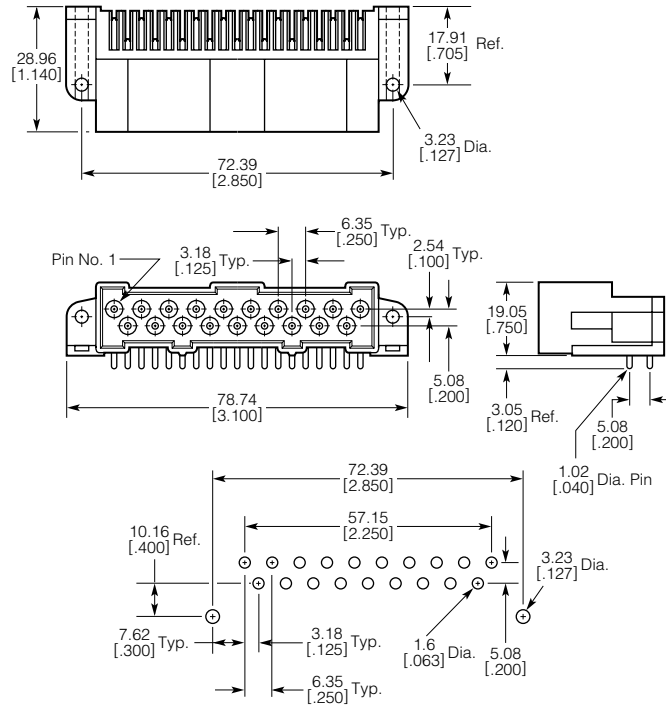

Recommended Pc Board Layout

In-Line Connectors

In-Line Coaxial Socket Headers, Straight-Thru (PC Board Mount)

3 Circuit Assembly Part No. 208708-1

Material and Finish (Coaxial Contacts)

Center Conductor - Copper Alloy plated 0.00127 [.000050] gold over 0.00076 [.000030] nickel

Outer Shell - Copper alloy, plated 0.00038 [.000015] gold over 0.00127 [.000050] nickel

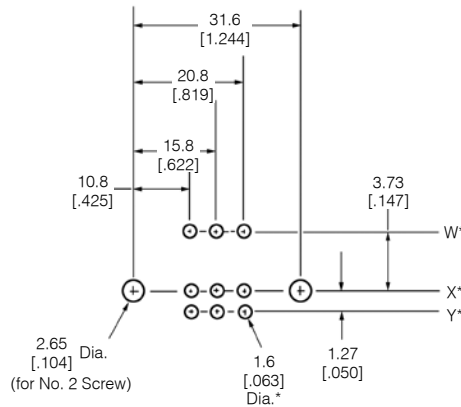
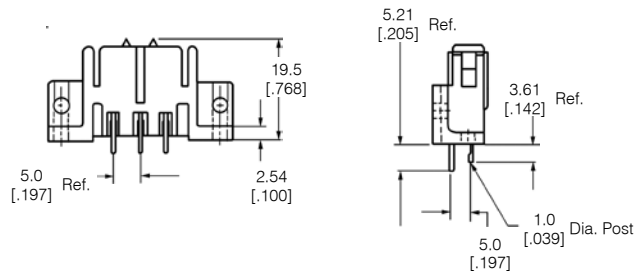
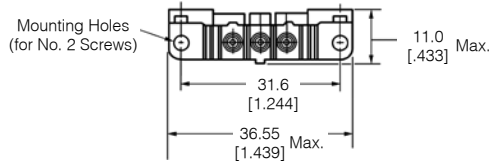

Recommended PC Board Layout

*Drill 1.6 [.063] Dia. holes in rows "W" and "Y" for subminiature coaxial contacts; and in row "X" only for power contacts.

- Notes:**
1. All cavities are preloaded with subminiature coaxial socket contacts.
 2. 3 circuit assembly mates with in-line receptacle. **Part No. 207359-1** (page 39).

In-Line Coaxial Socket Headers, Straight-Thru (PC Board Mount) (Continued)

10 Position Circuit Assemblies

Material and Finish

Coaxial Contacts

Center Conductor - Copper Alloy plated 0.00127 [.000050] gold over 0.00076 [.000030] nickel

Outer Shell - Copper alloy, plated 0.00038 [.000015] gold over 0.00127 [.000050] nickel

Power Contacts

Body - Copper Alloy plated 0.00076 [.000030] gold on mating area, 0.00381 [.000150] tin on remainder, both over 0.00127 [.000050] nickel

Hood - Stainless steel

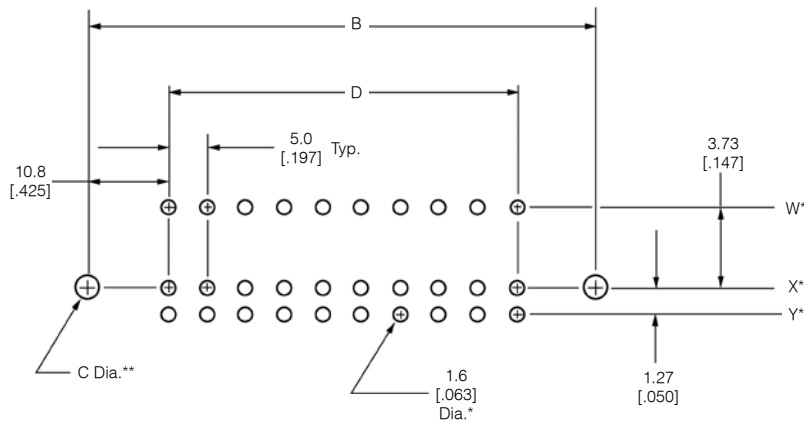
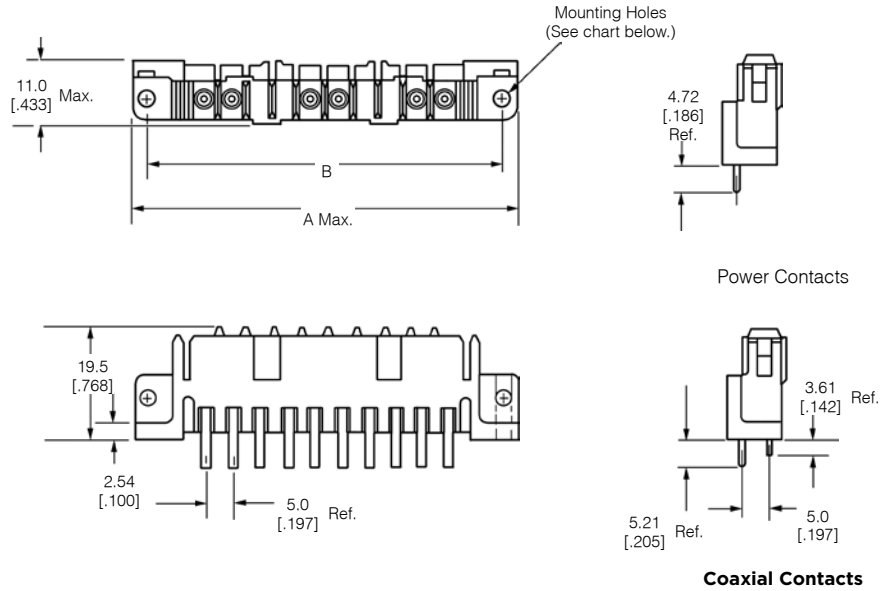

Recommended PC Board Layout

PC Board Layout

No. of Positions	Dimensions		
	B	C**	D
10	66.6 2.622	2.85 .112	45 1.772

**C Dia. = 2.85 [.112] for No. 3 Screw.

In-Line Coaxial Socket Headers, Straight-Thru

No. of Positions	Dimensions		Mounting Hole (for Screw Size)	Cavity Loading		Socket Header Part No.	Mates with In-Line Receptacle Part No.
	A	B		Coaxial Contacts	Power Contacts		
10	71.6 2.869	66.6 2.622	3	All 3, 8 thru 10	— 1, 2, 4 thru 7	208309-1 208309-3	207397-1 (page 39)

*Drill 1.6 [.063] Dia. holes in rows "W" and "Y" for subminiature coaxial contacts; and in row "X" only for power contacts.

In-Line Coaxial Socket Headers, Straight-Thru (PC Board Mount)

3 Circuit Assembly Part No. 208222-2

Material and Finish Coaxial Contacts

Center Conductor - Copper
Alloy plated 0.00127 [.000050]
gold over 0.00076 [.000030]
nickel

Outer Shell - Copper alloy,
plated 0.00038 [.000015] gold
over 0.00127 [.000050] nickel

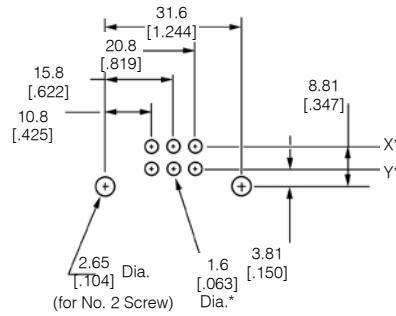
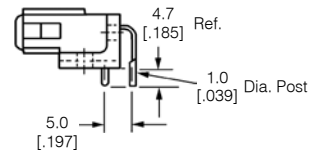
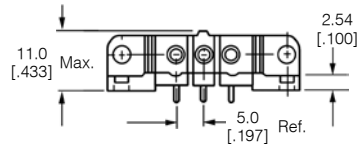
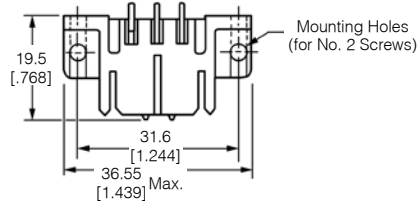

Recommended PC Board Layout

* Drill 1.6 [.063] Dia. holes in rows "X" and "Y" for subminiature coaxial contacts.

- Notes:**
1. All cavities are preloaded with subminiature coaxial socket contacts.
 2. 3 circuit assembly mates with in-line receptacle. **Part No. 207359-1** (page 39).

In-Line Coaxial Socket Headers, Straight-Thru (PC Board Mount) (Continued)

6 Circuit Assembly Part No. 208212-3

Material and Finish

Coaxial Contacts

Center Conductor - Copper alloy plated 0.00127 [.000050] gold over 0.00076 [.000030] nickel

Outer Shell - Copper alloy, plated 0.00038 [.000015] gold over 0.00127 [.000050] nickel

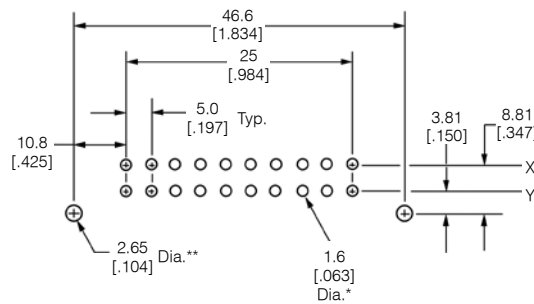
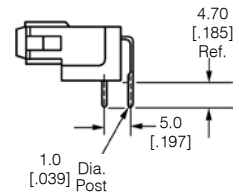
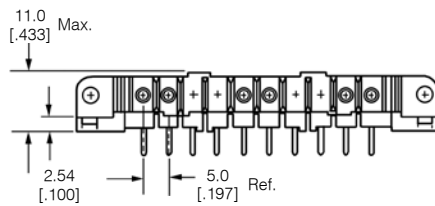
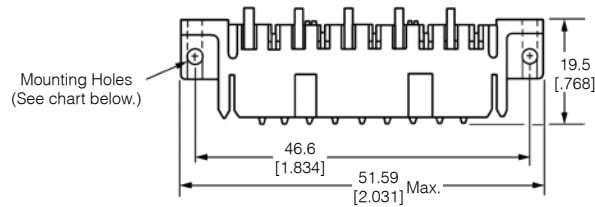

Recommended PC Board Layout

*Drill 1.6 [.063] Dia. holes in rows "X" and "Y" for subminiature coaxial contacts; and in row "Y" only for power contacts.

**Dia. = 2.65 [.104] for No. 2 Screw.

Notes: 1. All cavities are preloaded with subminiature coaxial socket contacts.

2. 6 circuit assembly mates with in-line receptacle. Part No. 207376-1 (page 39).

Rectangular Connectors

62 Position Rectangular Connector (Panel Mount)

Material

Black thermoplastic, 94V-0 rated

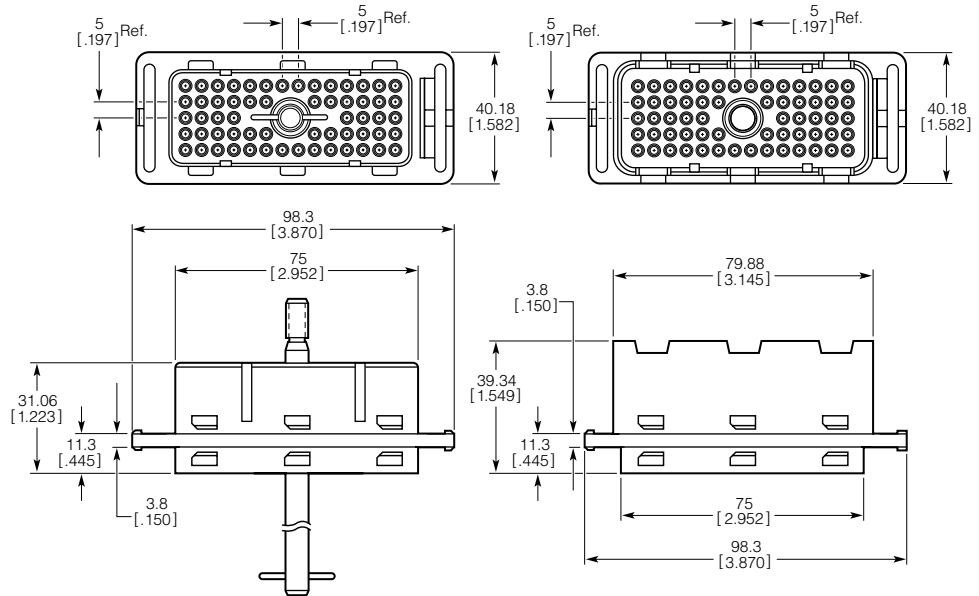

Rectangular Connector

Mating Half	With Male Jackscrew	With Female Jackscrew Threads	Pin Headers
Plug	208334-4 ¹	208627-1 ²	—
Receptacle	208628-1	—	211580-4 (19.76 [.778] posts) 211580-5 (3.56 [.140] posts)

¹Mates with 211580-4 or 211580-5.

²Mates with 208628-1.

Note: Housings shown with jackscrew in plug and female jackscrew threads in receptacle. Either half can be equipped with female jackscrew threads or jackscrew as necessary.

Rectangular Connectors

Recommended Panel Cutout for Front & Rear Mounted Plug and Rear Mounted Receptacle

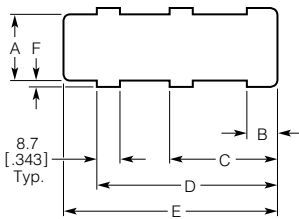

Recommended Panel Cutout (for Plug or Receptacle)

Panel Thickness	Dimensions*					
	A	B	C	D	E	F
0.8-1.4	29.9	13.3	41.7	68	82.7	2.6
.031-.055	1.177	.524	1.642	2.677	3.256	.102
1.4-2	32.2	13.3	41.7	68	82.7	1.6
.055-.078	1.268	.524	1.642	2.677	3.256	.063

Recommended Panel Cutout for Front Mounted Receptacle

Panel Thickness	Dimensions*					
	A	B	C	D	E	F
0.8-1.4	35.4	15.9	44.3	70.2	85.4	2.6
.031-.055	1.394	.626	1.744	2.764	3.362	.102
1.4-2	37.7	15.9	44.3	70.2	85.4	1.6
.055-.078	1.484	.626	1.744	2.764	3.362	.063

*All dimensional tolerances listed are +0.3 [.012, -.001].

Rectangular Connectors (Continued)

62 Position PC Pin Headers (Mates with Plug Part No. 208334-4)

Material

Black thermoplastic, 94V-0 rated

Related Product Data

Mateable Plug - Page 52

Performance Characteristics - Page 3

Technical Documents - Page 58

Product Specification - 108-10033

Application Specification - 114-10040

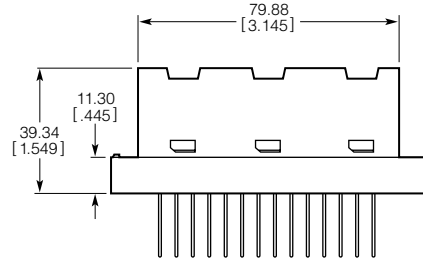
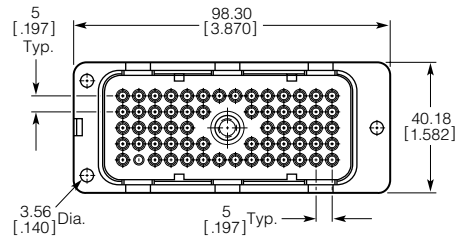

Part No. 211580-4 with posts 19.76 [.778]
Part No. 211580-5 with posts 3.56 [.140]

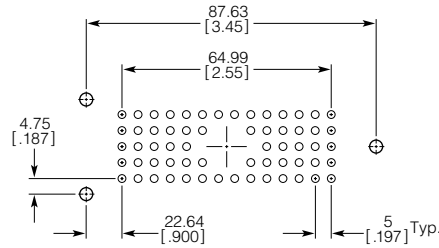

Recommended PC Board Layout

Commoning Connectors

Product Facts

- **36-circuit commoning system**
- **Choice of bussing configurations: full bus and split bus of 8-8-8-8-4.** Other arrangements are available, consult Tyco Electronics.
- **Compact design: 95.1 [3.744] x 33 [1.300]**
- **Mounts onto machine frame and other panel areas**

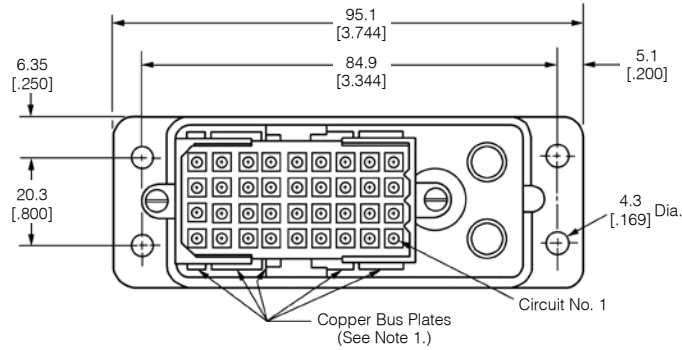

Material and Finish

Contacts - Copper alloy, tin plated

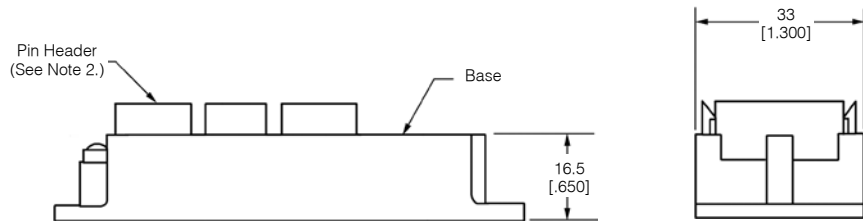

- Notes:**
1. See chart below for bus configurations.
 2. These connectors mate with 36-circuit Square Grid Plug **Part No. 207019-1** (page 31).
 3. Dimensional tolerances are not illustrated. This information is available on engineering drawings; use product part number when ordering drawings.

Bus Configuration	Commoning Arrangements	Part Number
Split 8-8-8-8-4	1 thru 8	208062-8
	9 thru 16	
	17 thru 24	
	25 thru 32	
Full	33 thru 36	208062-9
	All Circuits Common	

Power Distribution Connectors

Product Facts

- **36-circuit power distribution system**
- **High current capability**
- **Compact design: 95.1 [3.744] x 33 [1.300]**
- **Accommodates one or two voltages (with split bus)**

Bus Configuration	Contact Plating	Connector Part No.
Full Bus	Tin	208063-5
Split Bus (See Note 1.)	Tin	208063-6
	Gold/ Nickel ¹	208063-7

¹0.00076 [.000030] gold on mating area, 0.00381 [.000150] tin on remainder, both over 0.00127 [.000050] nickel.

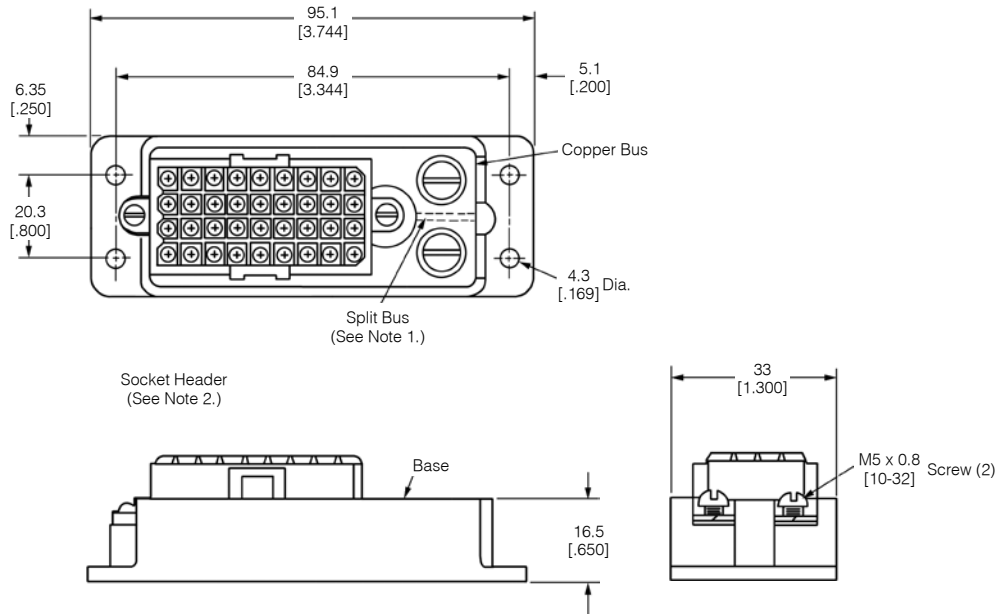

- Notes:**
1. Copper bus for **Part Nos. 208063-6** and **208063-7** is divided lengthwise, providing dual 18-circuit buses. Other bussing configurations can be made available, consult Tyco Electronics.
 2. These connectors mate with 36-circuit Square Grid Receptacle **Part No. 207020-1** (page 31).
 3. Dimensional tolerances are not illustrated. This information is available on Tyco Electronics engineering drawings; use product part number when ordering drawings.

Heat Rise Characteristics

The following graph indicates the maximum temperature rise of a power distribution connector with various currents being applied. The specific connector under test is a fully bussed, 36-circuit power distribution connector with 7-8 mm² [8 AWG] input wire. The mating connector is a standard 36-circuit Metrimate receptacle with all contacts terminated to 1 219 [48] leads using 2 mm² [14 AWG] wire.

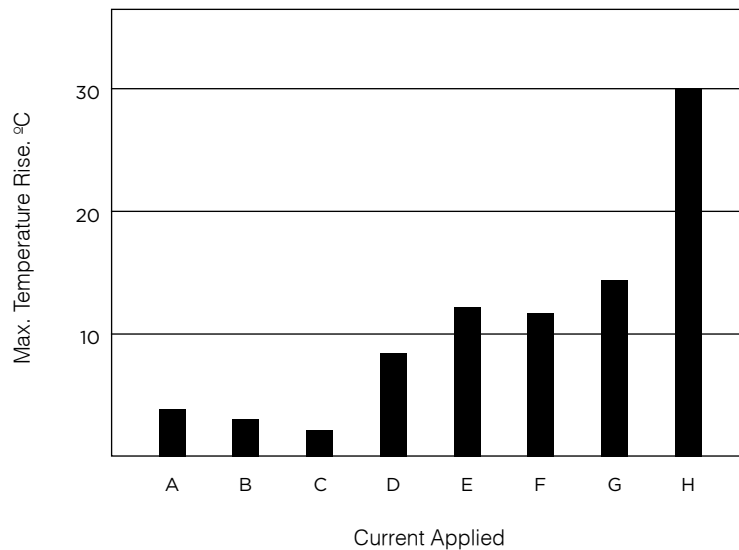

- A – 13 amperes, one central contact.
- B – 13 amperes (combined), two adjacent central contacts.
- C – 20 amperes (combined), four central contacts.
- D – 40 amperes (combined), four central contacts.
- E – 60 amperes (combined), four central, three end contacts.
- F – 50 amperes (combined), four corner contacts.
- G – 100 amperes (combined), 36 contacts.
- H – 155 amperes (combined), 36 contacts.

Application Tooling

Mechanical Hand Tools for Interchangeable Die Sets

These tools are ideal for small production, prototype and experimental applications. They are used for terminating pin and socket contacts to wire and feature a ratchet device to provide consistently formed crimps.

SDE (Standard Die Envelope) Die Sets



SDE die sets provide cost-effective flexibility, through many options for a common die-set outline. The SDE die sets can be adapted for use with CERTI-CRIMP hand tools, PRO-CRIMPER III hand tools, the SDE Terminator and the 626 Pneumatic Tool System.

For more information, request Catalog **1654003**.

PRO-CRIMPER III Hand Tool, Part No. 58495-1



Commercial grade hand tool for crimping various products. Features ratchet control to provide complete crimp cycle. Accepts both pinned- and shouldered-style die sets. Locators are provided with pinned-style die sets for proper contact and wire positioning, and to help minimize contact rotation and bending during crimping. Approximate weight 1.3 lb [0.60 kg].

For use with Type III+ contacts, see pages 17-19. For more information, request Catalog **1773379-1**, Instruction Sheet **408-9930**.

CERTI-CRIMP Straight Action Hand Tools (SAHT)



172076

Premium grade hand tools. Feature ratchet control to provide complete crimp cycle. Die sets close in a straight line. Include a contact locator and wire stop, plus an insulation crimp adjustment lever, when applicable. Approximate weight 1.3 lb [0.59 kg].

For Type III+ contacts, see pages 17-19. For more information, request Catalog **65780**.

CERTI-CRIMP "C" Head Straight Action Hand Tool (SAHT), Part No. 69710-1



920648

Premium grade hand tool. Features ratchet control to provide complete crimp cycle. The interchangeable die sets close in a straight line to minimize contact or terminal rotation during crimping. When applicable, user-assist features such as a contact or terminal locator and a wire stop, are built into the die set. Approximate weight 1.9 lb [0.86 kg].

For subminiature coaxial contacts, see pages 22-23. For more information, request Catalog **65780**, Instruction Sheet 408-2095.

Electric Machine for Interchangeable Die Sets

SDE Terminator, Part No. 1490076-2



112869

An electric crimp terminator with compact design features a die set holder that is compatible with all AMP SDE (PRO-CRIMPER III Tool) die sets. Hand- or foot-actuated options are available. CE Approved.

For more information, request Catalog **1654714**.

Application Tooling (Continued)

Pneumatic Hand Tool for Interchangeable Die Sets

6-26 Pneumatic Tool System

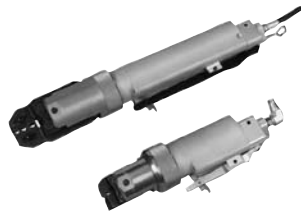

Effortless crimping for a broad range of terminals, either bench-mounted or hand-held for working in cramped quarters.

- Lightweight tool eliminates physical force required by hand tools
- Hand- or foot-switch operation
- Termination wire range from 26-6 AWG [0.12-13.0mm2], plus coaxial

and fiber optic cable

- Works with existing AMP-compatible crimp heads and die sets
- Ratchet control option provides complete crimp cycle, eliminating partial crimps
- Use rotating head assembly to reach difficult termination locations

For more information, request Catalog **124208**.

Battery-Powered Crimp Tool Kits



The Battery-Powered Crimp Tool Kit is a fast, ergonomically-designed tool is ideal for use at the bench, on the line, or in the field. It's completely portable, lightweight (3.48 lbs including battery) and compact. The charge delivers over 100 crimps - charge time is 40 mins. The kit includes the tool, 2 batteries and the charger.

P/N 1213890-1 — SDE Battery Powered Crimp Tool Kit (dies not included)

P/N 1213805-1 — CERTI-CRIMP II, SA Battery Powered Crimp Tool Kit (heads not included)

P/N 1213840-1 — CERTI-CRIMP, Large Die, C-Head Adapter Battery Powered Crimp Tool Kit (dies not included)

P/N 1213819-1 — CERTI-CRIMP, Large Die, Straight-Action Adapter Battery Powered Crimp Tool Kit (dies not included)

For more information, request Catalog **1773381**.

CRIMP MACHINES

AMP-O-LECTRIC Model "G" Terminating Machines, Part Nos. 354500-1, -9, -11



Semiautomatic bench machines for crimping reeled terminals and contacts, featuring a quiet and reliable direct motor drive, microprocessor controls for ease of setup and operation, and guarding and lighting designed for operator convenience and safety. All models are equipped with either manual or automatic precision adjustment of crimp height. Machine-mounted sensors are available for crimp quality monitoring using conventional miniature-style applicators.

For more information, request Catalog **1654956-2**, Video **198116**, Catalog **82275 [Crimp Quality Monitor (CQM)]**, Video **198094**.

Note: New Stripping Module available, see page 79.

AMP-TAPETRONIC Machine, Part No. 69875

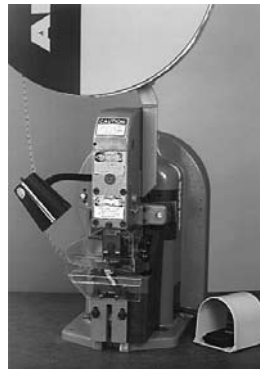

AMP-O-LECTRIC Model "K" Terminating Machine with a permanently-mounted applicator that accepts interchangeable die sets to apply a variety of tape-mounted terminals and splices. Many of the die sets can also be used in AMP-O-LECTRIC Terminating Machines with a tape applicator.

For more information, contact Tyco Electronics.

Application Tooling (Continued)

Crimp Quality Monitor (CQM)

Part No. 1320420-2



The unique system provides 100% on-the-fly crimp inspection. It measures the crimp height of each termination, and evaluates the quality of each crimp. If a crimp is questionable, the monitor alerts the operator with both visual and audible alarms. It also provides ports for printing and networking. When used with AMP-O-LECTRIC Model "G" Termination Machines, the monitor is mounted to the machine. When used with AMPOMATOR CLS IV Lead Making Machines, it is integrated into the machine's operating system.

For more information, request Catalog **82275**.

AMP 3K/40 and AMP 5K/40 Terminating Machines



The AMP 3K/40 and AMP 5K/40 Terminators are designed for customers that require the increased output and quality of a semiautomatic machine at a competitive price. By incorporating the most commonly requested features as standard and offering a long list of optional equipment, these terminators offer flexibility to meet the specific needs of various applications at the lowest possible cost.

Features

- 3,000 lb [1361 kg] max. crimp force (AMP 3K/40);
- 5,000 lb [2268 kg] max. crimp force (AMP 5K/40)
- Toolless removal of applicators and guards
- Jog capability
- Quiet, fast operation - 80/76 dBA and cycle time less than 0.400 seconds
- Accepts Heavy Duty Mini style applicators
- Wide range of optional equipment such as toolless precision crimp height adjust, batch counter, CQM capability and work light

For more information, request Catalog **1654956-2**.

Note: New Stripping Module available, see page 79.

Crimp Force Monitor (CFM)



Your Quality Program calls for more than a Good Crimping System. It demands proof — the proof you get with the SLE crimp force monitor. It has high-resolution piezo-quartz sensor technology for a more precise identification of typical crimping faults.

Sure, you can sample and test crimp height with a micrometer. In fact, that's how you standardize your process. But for ongoing quality control, testing every crimp, SLE is the choice.

It's known worldwide, and meets our standards or a high performance terminating system. That's how you can be sure.

High quality crimping — with verification — means higher production and productivity.

Features

- 1 or 2 Channels
- 128 x 128 Dot Matrix
- Zone & Peak Force Analysis
- Force Trigger
- Encoder Proximity Trigger
- Absolute Force Measurement
- Monitors the wire barrel crimp of open-barrel, uninsulated contacts and terminals
- Real-time monitoring of every crimp
- Special applicators are not required
- Use with the AMP-3K/40 and AMP-5K/40 presses from Tyco Electronics
- Frame-mounted force sensor
- For bench or fully-automatic machines
- Please contact us for any other type of press you would like to use with the CFM

Crimp Force Monitor Specifications

- Electrical: 110-230 VAC Single Phase, 50-60 Hz, 15 watts
- Size (Monitor): 178mm x 137mm x 95mm
- Weight (Monitor): 1.02kg (single channel), 1.05kg (double channel)

For more information, request Catalog **1309085-2**

System III Applicator



The System III Applicator introduces several new technologies into the applicator including a precision servo-electric motorized feeding system, a built-in data module for storing terminal crimp and set-up information, a precision fit round ram, and a newly designed terminal depressor. It still utilizes the proven quality of the HD-M crimper and anvil tooling.

For more information, request Catalog **1654956-8**

Application Tooling (Continued)

LEAD MAKERS

Komax gamma 333 PC Lead-Making Machine



This fully-automatic, PC-controlled leadmaker can be equipped with up to three processing stations enabling the crimping of both ends of the wire, double-crimp connections with three different contacts, single-ended seal applications, tinning or ink-jet marking. Features include ultra-short conversions times, easy-to-use graphic-based TopWin interface with multiple-language capability, crimp force analyzer with statistical analysis, seal monitoring, and integrated good/bad sorting.

For more information, request Catalog **1307901**.

AMPOMATOR System III Leadmaker



The AMPOMATOR System III Leadmaker is designed for the demands of low-volume/high mix manufacturing and precision quality. This leadmaker combines the best wire processing capabilities with new technologies in terminal feeding and machine set-up found in the System III Applicator to offer significant advantages for higher throughput and efficiencies.

For more information, request Catalog **1654956-5**

Komax 433-S alpha Lead-Making Machine

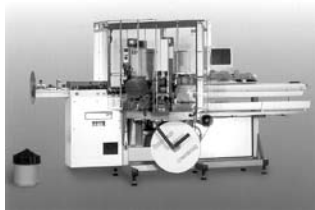

The 433-S alpha offers maximum flexibility for applying seals to one or both ends of the wire with the corresponding terminal. When equipped with the mci 711 crimp terminator and mci 761 seal applicator, the fully-automated 433-S alpha forms a highly compact system with optimum accessibility. Dynamic servo-drives provide fine travel settings on all motor axes and the wire straightening unit with quick-release lock and automatic lead-in feature reduces wire changeover time. The TopWin software provides for fast, simple data input.

For more information, request Catalog **1307801**.

APPLICATORS

End-Feed Heavy-Duty Miniature Applicators (coded HDM)



Interchangeable applicators for crimping products reeled end-to-end (primarily open-barrel terminals). Used in bench and lead-making machines; most designs can be used, or adapted for use with minor tooling changes, dial-in settings for different wire sizes and insulation diameters. Mechanical or air-powered feed systems, depending on the product applied.

For more information, request Catalog **296393-2** and Instruction Sheet **408-8039**.

EDGE Applicator Counter



The new EDGE counter tracks wearable tool usage for the most effective maintenance planning. The completely electronic counter, with clear LCD display, indicates cycles since installation. By performing maintenance at measured intervals with pre-set limits, operators avoid breakdowns and rejects caused by tool wear or mis-adjustment. A wireless interface transfers counters to a PC running the optional Edge Counter Software Pack.

The EDGE is standard on all new applicators and can be retrofitted to most existing Tyco Electronics applicators.

For more information, request Catalog **1773385**.

Side-Feed Heavy-Duty Miniature Applicators (coded HDM)



Interchangeable applicators for crimping products reeled side-by-side on single or dual carrier strips (primarily closed-barrel terminals and open-barrel contacts). Similar design as the end-feed version. All side-feed applicators include a wire stop to help correctly position the wire end in the crimping target area.

For more information, request Catalog **296393-2** and Instruction Sheet **408-8040**.

Application Tooling (Continued)

Stripper-Crimper Applicators (coded SCA)



Interchangeable applicators for crimping products in AMP-O-MATIC Stripper-Crimper Machines. Consist of separate ram and lower tooling assemblies. Similar dial-in settings for different wire sizes and insulation diameters as HDM applicators. Available with sensors for use with the Crimp Quality Monitor.

For more information, request Catalog **65004 (AMP-O-MATIC Stripper-Crimper Machines)**, Catalog **82275 [Crimp Quality Monitor (CQM)]**.

Cosmic 30M Wire Stripping Machine, 5-528367-0



The Cosmic 30M is a high precision, high speed electrical wire stripper that is very easy to operate. It's equipped with a four blade system and an optional gripper for more difficult wires. There is a digital display for the wire diameter that can be set at 0.01 mm increments.

For more information, request Catalog **1773385-2**.

Cosmic 927R Micro-Cable Stripper



The compact, lightweight, benchtop Cosmic 927R was designed and developed to reliably strip various insulation materials and micro-cable. From conductor diameter 36 to 10 AWG, the stripping diameter display can be set to within 0.1 mm increments.

For more information, request Catalog **1773385-4**.

STRIPPER-CRIMPER MACHINES

AMP-O-MATIC Stripper-Crimper Machines, Part Nos. 1320895-1, -2



Semiautomatic bench crimping machines that also strip the wire, and are therefore used for terminating jacketed cable. Feature manual precision adjustment of crimp height, keyed strip blades for faster, more accurate setups, and an efficient scrap removal system. All adjustments can be made from the front of the machines without special tools. Available with crimp quality monitoring.

For more information, request Catalog **65004**, Video **198075**, Catalog **82275 [Crimp Quality Monitor (CQM)]**, Video **198094**.

Stripping Module (for the AMP 3K/40 and AMP 5K/40 Terminating Machines and AMP-O-LECTRIC Model "G" Terminator on page 77)

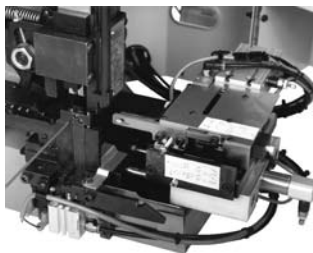

The combination of the Stripping Module with the AMP 3K/40 and AMP 5K/40 Terminating Machines or the AMP-O-LECTRIC Model "G" Terminator provides an economic and proficient method of stripping the wire and crimping terminals on the same machine. The module accepts End- and Side-Feed HDM Applicators (32-14 AWG) and operates in three modes: crimp only, strip only, or strip and crimp. It can be installed on existing machines in the field or purchased as one unit from the factory.

For more information, request Catalog **1309085**.

Technical Documents

The following is a list of technical documents covering the application, performance and maintenance of Metrimate Connectors.

Product Specifications describe technical performance characteristics and verification tests. They are intended for the Design, Component and Quality Engineer.

- 108-10033 Metrimate Connectors
- 108-10042 Contacts, Type III+ Stamped and Formed
- 108-12011 Subminiature COAXICON Contacts
- 108-1317 Power Drawer Connectors
- 108-1682 Power Drawer Connectors with .125 POWERBAND Contacts
- 108-1449 Power Drawer with High Current Louvertac Size 8
- 108-10033-1 Metrimate Connectors loaded with contacts

Application Specifications describe requirements for using the product in its intended application and/or crimping information. They are intended for the Packaging and Design Engineer and the Machine Setup Person.

- 114-10014 Contacts, Pin and Socket, Power Application of
- 114-10004 Contacts, Type III+
- 114-10039 Drawer Connectors
- 114-10040 Metrimate Connectors
- 114-10043 POWERBAND Contacts

Instruction Sheets provide instructions for assembling or applying the product. They are intended for the Manufacturing Assembler or Operator.

- 408-7846 Metrimate Connectors (Square Grid)
- 408-1379 Pin and Socket Contacts
- 408-7347 Insertion Tool 91002-1, Type III+ Contacts
- 408-2024-2 Subminiature COAXICON Contacts, Instruction, Maintenance and Inspection
- 408-1216 Extraction Tool 305183, Type III+ and Subminiature COAXICON Contacts
- 408-4374 Extraction Tool 318813-1
- 408-4391 CERTI-CRIMP SAHT 90716-1
- 408-8547 Operation and Maintenance of CERTI-CRIMP II Straight Action Hand Tools
- 408-7414 CERTI-CRIMP SAHT 90225-2
- 408-9819 PRO-CRIMPER II Hand Tool 58495-1
- 408-1817 Insertion Tool 200893-2
- 408-2095 "C" Head Hand Tool 69710-1
- 408-9930 PRO-CRIMPER II Hand Crimping Tool Frame Assembly 354940-1

Customer Manuals provide a compilation of customer prints, product specifications, application specifications, features and benefits, IS sheets, test specifications and could include a product catalog.

- 409-5862 AMP 626 Pneumatic Tool Assemblies

Part Number Index

Note: This numerical index lists all cataloged part numbers by base number only. Complete part numbers (with prefixes and/or suffixes) are shown on the page indicated.

Part No.	Page No.
51565	13, 14
66098	9
66099	9
66100	9
66101	9
66102	9
66103	9
66104	9
66105	9
66106	9
66107	9
66108	9
66109	9
66331	9
66332	9
66358	9, 12
66359	9, 12
66360	9, 12
66361	9, 12
66393	9
66394	9
66399	9
66400	9
66405	9
66406	9
66424	9
66425	9
66428	9
66429	9
66563	9
66564	9
66565	9
66566	9
66597	9, 12
66598	9, 12
66601	9, 12
66602	9, 12
164159	10
164160	10
164161	10
164162	10
164163	10
164164	10
193457	16
193458	16
193534	16
193535	16
193642	16
193643	16
193814	16
193844	11
193846	11
194264	11
202236	10
202237	11
206763	34
207015	31, 34
207016	31, 34
207017	31, 34
207018	31, 34
207019	31, 34, 54

Part No.	Page No.
207020	31, 34, 55
207088	31
207119	34
207120	34
207121	34
207152	31, 34
207153	31, 34
207158	34
207304	31, 34
207305	31, 34
207359	39, 41, 48, 50
207360	39, 41
207365	41
207376	39, 41, 51
207377	39, 41
207378	41
207396	39, 41
207397	39, 41, 49
207398	41
207439	31, 34
207440	31, 34
207441	34
207442	31, 34
207443	31, 34
207444	34
207496	34
207524	34
207526	34
207528	34
207530	34
207532	34
207534	34
207535	39
207541	41
207542	39, 41
207543	39, 41
207544	41
207583	41
207584	41
207599	41
207600	31
207601	31
207602	31
207603	31
207604	31
207608	41
207609	41
207610	41
207611	41
207612	41
207613	41
207614	41
207615	41
207654	44
208062	54
208063	55
208099	44
208100	44
208116	44
208117	44
208209	18
208210	18
208211	20
208222	50
208309	49
208212	51

Part No.	Page No.
208334	52, 53
208400	44
208403	44
208404	44
208627	52
208628	52
208708	48
211076	39
211108	44
211149	18
211150	18, 24
211580	52, 53
211758	18
211759	18
212008	15
212014	15
212608	18
212609	18
212630	44
213283	20
213426	16, 19
213427	16, 19
213499	16, 19
213500	16, 17, 19
213552	15
213558	18
213567	15
213662	15
213672	18
213713	19
213737	15
213738	18
213740	15
213748	18
213749	18
213750	15
213752	19
213766	27, 29
213768	27, 29
213784	18
213792	31
213793	31
213794	31
213795	31
213796	31
213797	31
213824	18
213841	17
213843	17
213845	17
213847	17
213881	18
213882	19
213883	19
213886	17, 19
213908	19
213940	27, 28
213942	27
213973	27, 30
213974	27, 30
225088	13
226537	13, 14
266180	10
266181	10
266182	10
266183	10

Part No.	Page No.
332056	13
332057	13, 14
788085	9
788088	9
796964	11
796966	11

Tooling

58495	9, 10
69656	13, 14
69690	13, 14
69710	13, 14, 17, 57
90225	9
90716	9
91002	9
91505	9, 10
91515	9, 10
91519	9
91521	9
91523	9, 10
91542	9
91911	13, 14
189721	9, 10, 13, 14, 17
189722	9, 10, 13, 14, 17
189928	9, 10, 13, 14
200893	9
305183	9, 11, 12, 13, 14, 16
318161	13, 14, 17
318813	16
354500	17
354940	13, 14
356114	16
356304	9, 10, 13, 14, 17
356336	16
356611	17
356612	17
466321	9
466323	9, 10
466324	9
466325	9
466326	9
466383	9
466585	9
466598	9
466741	10
466906	9
466907	9, 10
466908	9
466923	9
466942	9
466958	9
466979	9
567363	9
567364	9
567867	9
567947	9
601967	12
608651	15
608668	15
680114	10
680195	17
680197	17
680602	9
725840	10

Engineering Notes



Mouser Electronics

Authorized Distributor

Click to View Pricing, Inventory, Delivery & Lifecycle Information:

[TE Connectivity:](#)

[208334-4](#)