

Mono DAC with 2.6W Class AB/D Speaker Driver, Dynamic Range Controller and ReTune™ Mobile Parametric Equalizer

DESCRIPTION

The WM9081 is designed to provide high power output at low distortion levels in space-constrained portable applications.

ReTune™ Mobile Parametric EQ with fully programmable coefficients is integrated for optimization of speaker characteristics. Programmable dynamic range control is also available for maximizing loudness, protecting speakers from clipping and preventing premature shutdown due to battery droop.

Digital input enables the power drivers to be located close to the speakers in multi-channel systems without the need for troublesome long analogue connections. Location of the power drivers close to the speakers also removes the need for bulky and expensive class D filters and reduces PCB track lengths, minimising emissions. The digital input can also help to minimise crosstalk to the speaker output signal from high gain microphone inputs, enhancing stability and reducing the risk of 'howling' during speakerphone operation.

Four control interface addresses and four-channel TDM are supported to allow multiple devices to be configured and driven independently.

The device is controlled via a standard 2-wire, 3-wire, or 4-wire control interface or by hardware control pins.

FEATURES

- High-power, high performance DAC and speaker driver
 - 92dB SNR ('A-weighted') in Class D mode
 - 97dB SNR ('A-weighted') in Class AB mode
 - <0.05% THD+N @0.5W continuous into 4Ω (Class D)
 - <0.10% THD+N @2W continuous into 4Ω (Class D)
 - 2.6W maximum peak power
- ReTune™ Mobile Parametric Equalizer
 - Fully programmable filter coefficients
- Programmable dynamic range controller
 - Boosts small signals to maximise loudness
 - Protects against battery droop and clipping
- Speaker common mode boost
 - Maximises power for a given SPKVDD/AVDD ratio
- Low power FLL
 - Provides all necessary internal clocks
 - 32kHz to 27MHz input frequency
- All common sample rates from 8kHz to 96kHz supported
- Standard 2-wire, 3-wire, 4-wire and hardware control modes
- Data formats: LJ, RJ, I²S, DSP, all with TDM support
- Thermal shutdown interrupt
- 4x4 COL package (0.45mm lead pitch)
- Operating temperature range: -40°C to 85°C

APPLICATIONS

- Portable navigation systems
- Mobile phones
- Flat panel TVs

BLOCK DIAGRAM

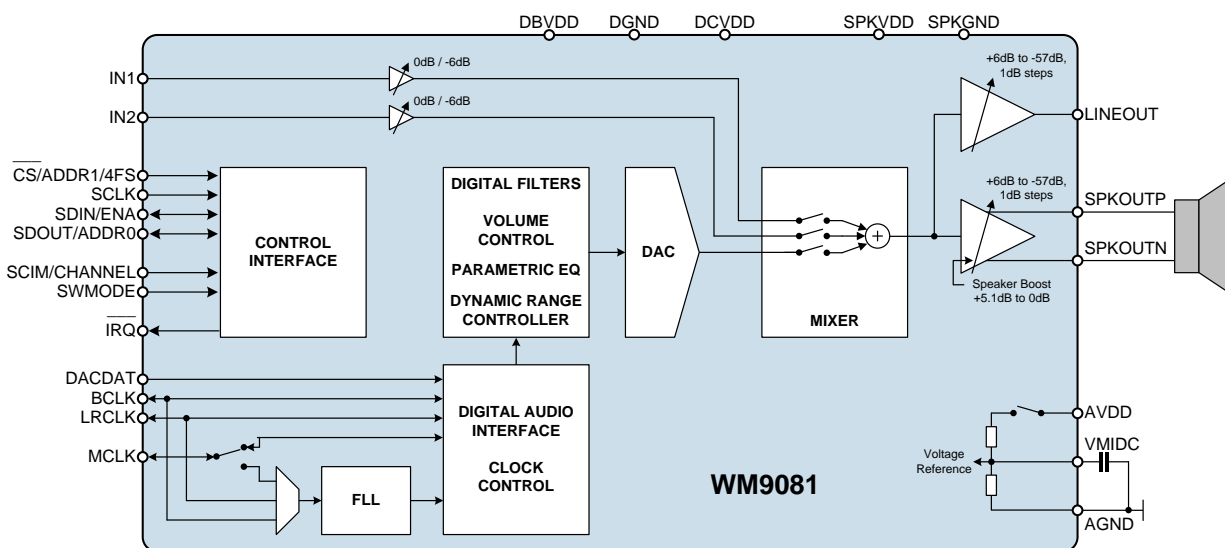

TABLE OF CONTENTS

DESCRIPTION	1
FEATURES	1
APPLICATIONS	1
BLOCK DIAGRAM	1
TABLE OF CONTENTS	2
PIN CONFIGURATION	3
ORDERING INFORMATION	3
PIN DESCRIPTION	4
ABSOLUTE MAXIMUM RATINGS	5
RECOMMENDED OPERATING CONDITIONS	5
ELECTRICAL CHARACTERISTICS	6
COMMON TEST CONDITIONS	6
AUDIO DAC	6
DIGITAL INTERFACES.....	8
CLOCKING AND TIMING.....	8
TYPICAL POWER CONSUMPTION	9
COMMON TEST CONDITIONS	9
POWER CONSUMPTION MEASUREMENTS.....	9
TYPICAL PERFORMANCE DATA	11
SPEAKER CLASS D INTO 4Ω + 10μH	11
SPEAKER CLASS D INTO 8Ω + 10μH	11
SIGNAL TIMING REQUIREMENTS	12
SYSTEM CLOCK TIMING.....	12
AUDIO INTERFACE TIMING – MASTER MODE	13
AUDIO INTERFACE TIMING – SLAVE MODE	14
CONTROL INTERFACE TIMING – 2-WIRE MODE.....	15
CONTROL INTERFACE TIMING – 3-WIRE MODE.....	16
CONTROL INTERFACE TIMING – 4-WIRE MODE.....	17
DEVICE DESCRIPTION	18
INTRODUCTION.....	18
CONTROL INTERFACE (SOFTWARE MODE)	19
CONTROL INTERFACE (HARDWARE MODE)	24
CONTROL WRITE SEQUENCER.....	27
POWER ON RESET CIRCUIT	30
DYNAMIC RANGE CONTROLLER (DRC)	32
RETUNE MOBILE PARAMETRIC EQUALIZER (EQ).....	37
DIGITAL TO ANALOGUE CONVERTER (DAC)	40
SIGNAL PATH CONTROL	42
ANALOGUE OUTPUTS	44
POP SUPPRESSION CONTROL	47
DIGITAL AUDIO INTERFACE	48
DIGITAL AUDIO INTERFACE CONTROL	54
CLOCKING AND SAMPLE RATES.....	58
THERMAL SHUTDOWN	67
INTERRUPTS	68
REFERENCE VOLTAGES AND MASTER BIAS	70
POWER MANAGEMENT	72
CHIP RESET AND ID.....	73

PIN DESCRIPTION

PIN NO	NAME	TYPE	DESCRIPTION
1	LRCLK	Digital Input / Output	Audio interface DAC left / right clock
2	DACDAT	Digital Input	DAC digital audio data
3	DCVDD	Supply	Digital core supply
4	DBVDD	Supply	Digital buffer (I/O) supply
5	DGND	Supply	Digital ground (Return path for both DCVDD and DBVDD)
6	SWMODE	Digital Input	Selects hardware or software control mode
7	SCIM/CHANNEL	Digital Input	2-wire or 3-wire control select (Software mode) / Left / right data channel select (Hardware mode)
8	CS/ADDR1/4FS	Digital Input	3-wire chip select or 2-wire address select (Software mode) / Normal fs input or 4fs input select (Hardware mode)
9	SDIN/ENA	Digital Input / Output	Control interface data input (Software mode) / Device enable (Hardware mode)
10	SCLK	Digital Input	Control interface clock input (Software mode)
11	SDOUT/ADDR0	Digital Input/ Output	4-wire data output or 2-wire address select (Software mode)
12	IRQ	Digital Output	Interrupt signal
13	SPKOUTP	Analogue Output	Positive BTL speaker output
14	SPKGND	Supply	Speaker ground (1) (Return path for SPKVDD)
15	SPKGND	Supply	Speaker ground (2) (Return path for SPKVDD)
16	SPKOUTN	Analogue Output	Negative BTL speaker output (1)
17	SPKOUTN	Analogue Output	Negative BTL speaker output (2)
18	SPKVDD	Supply	Speaker supply (1)
19	SPKVDD	Supply	Speaker supply (2)
20	IN2	Analogue Input	Line input
21	IN1	Analogue Input	Line input
22	LINEOUT	Analogue Output	Line output
23	VMIDC	Reference	Mid-rail voltage (VMID) decoupling connection
24	AGND	Supply	Analogue ground (Return path for AVDD)
25	AVDD	Supply	Analogue supply
26	NC		Not connected
27	MCLK	Digital Input / Output	Master clock
28	BCLK	Digital Input / Output	Audio interface bit clock

ABSOLUTE MAXIMUM RATINGS

Absolute Maximum Ratings are stress ratings only. Permanent damage to the device may be caused by continuously operating at or beyond these limits. Device functional operating limits and guaranteed performance specifications are given under Electrical Characteristics at the test conditions specified.



ESD Sensitive Device. This device is manufactured on a CMOS process. It is therefore generically susceptible to damage from excessive static voltages. Proper ESD precautions must be taken during handling and storage of this device.

Cirrus Logic tests its package types according to IPC/JEDEC J-STD-020B for Moisture Sensitivity to determine acceptable storage conditions prior to surface mount assembly. These levels are:

MSL1 = unlimited floor life at <30°C / 85% Relative Humidity. Not normally stored in moisture barrier bag.

MSL2 = out of bag storage for 1 year at <30°C / 60% Relative Humidity. Supplied in moisture barrier bag.

MSL3 = out of bag storage for 168 hours at <30°C / 60% Relative Humidity. Supplied in moisture barrier bag.

The Moisture Sensitivity Level for each package type is specified in Ordering Information.

CONDITION	MIN	MAX
Supply voltages (excluding SPKVDD)	-0.3V	+4.5V
SPKVDD	-0.3V	+7V
Voltage range digital inputs	DGND -0.3V	DBVDD +0.3V
Voltage range analogue inputs	AGND -0.3V	AVDD +0.3V
Junction temperature, T _J	-40°C	+150°C
Storage temperature after soldering	-65°C	+150°C

Notes

- Analogue, digital and speaker grounds must always be within 0.3V of each other.

RECOMMENDED OPERATING CONDITIONS

PARAMETER	SYMBOL	MIN	TYP	MAX	UNIT
Digital supply range (Core)	DCVDD	1.71	1.8	3.6	V
Digital supply range (Buffer)	DBVDD	1.71	1.8	3.6	V
Analogue supplies range	AVDD	2.7	3.3	3.6	V
Speaker supply range	SPKVDD	2.7	5.0	5.5	V
Ground	DGND, AGND, SPKGND		0		V
Ambient temperature, T _A		-40		+85	°C
Junction temperature, T _J		-40		+125	°C

Notes

- All digital and analogue supplies are completely independent from each other (i.e. not internally connected).
- DCVDD must be less than or equal to AVDD.
- DCVDD must be less than or equal to DBVDD.
- AVDD must be less than or equal to SPKVDD.
- SPKVDD must be high enough to support the peak output voltage when using DCGAIN and ACGAIN functions, to avoid output waveform clipping.
- Junction temperature is a function of ambient temperature and of the device operating conditions. The ambient temperature limits and the junction temperature limits must both be observed.

ELECTRICAL CHARACTERISTICS

COMMON TEST CONDITIONS

Unless otherwise stated, the following test conditions apply throughout the following sections:

- DCVDD = DBVDD = 1.8V, AVDD = 3.3V, SPKVDD = 5.0V
- PGA gain = 0dB
- ACGAIN=DCGAIN=1.52
- Audio signal: 1kHz sine wave, sampled at 48kHz with 24-bit data resolution, I²S mode
- Ambient temperature: T_A = +25°C
- C_{VMID} = 4.7μF
- VMID_SEL[1:0] = 01 (2x40kΩ)

Additional, specific test conditions are given within the relevant sections below.

AUDIO DAC

TERMINOLOGY

1. Signal-to-Noise Ratio (dB) – SNR is a measure of the difference in level between the maximum theoretical full scale output signal and the output with no input signal applied.
2. Total Harmonic Distortion (dB) – THD is the level of the rms value of the sum of harmonic distortion products relative to the amplitude of the measured output signal.
3. Total Harmonic Distortion plus Noise (dB) – THD+N is the level of the rms value of the sum of harmonic distortion products plus noise in the specified bandwidth relative to the amplitude of the measured output signal.
4. All performance measurements carried out with 20kHz low pass filter, and where noted an A-weighted filter. Failure to use such a filter will result in higher THD and lower SNR readings than are found in the Electrical Characteristics. The low pass filter removes out of band noise; although it is not audible it may affect dynamic specification values.
5. Mute Attenuation – This is a measure of the difference in level between the full scale output signal and the output with mute applied.

DAC TO SPEAKER OUTPUT

PARAMETER	TEST CONDITIONS	MIN	TYP	MAX	UNIT
DAC to Speaker Output (4.1Ω + 22μH BTL Load)					
SNR (A-weighted)	DAC to speaker output, class D	85	92		dB
THD+N (P _O =0.5W)			-72		dB
THD+N (P _O =1.0W)			-72		dB
THD+N (P _O =2.0W)			-68	-50	dB
SNR (A-weighted)	DAC to speaker output, class AB	90	97		dB
THD+N (P _O =0.5W)			-86		dB
THD+N (P _O =1.0W)			-86		dB
THD+N (P _O =2.0W)			-80	-50	dB

PARAMETER	TEST CONDITIONS	MIN	TYP	MAX	UNIT
Power Supply Rejection (20Hz – 20kHz)					
SPKVDD PSRR	400mV pk-pk at 217Hz on SPKVDD; DAC to speaker output, class D		75		dB
	400mV pk-pk at 217Hz on SPKVDD; DAC to speaker output, class AB		85		dB
AVDD PSRR	100mV pk-pk at 217Hz on AVDD; DAC to speaker output, class D		60		dB
	100mV pk-pk at 217Hz on AVDD; DAC to speaker output, class AB		60		dB

DAC TO LINE OUTPUT

PARAMETER	TEST CONDITIONS	MIN	TYP	MAX	UNIT
DAC to Line Output (10kΩ / 50pF Load)					
SNR (A-weighted)	DAC to line out, 0dBFS input	90	99		dB
THD+N			-83	-75	dB
Power Supply Rejection					
AVDD PSRR	100mV pk-pk at 217Hz on AVDD; DAC to line output		50		dB

OUTPUT CHARACTERISTICS

PARAMETER	TEST CONDITIONS	MIN	TYP	MAX	UNIT
Speaker Load Resistance		4			Ω
Line Out Load Resistance		5	10	100	kΩ
Line Out Capacitance				2	nF
Maximum Continuous Speaker Output Power	Class D mode		2		W
	Class AB mode		2		W
Maximum Peak Speaker Output Power	Class D mode		2.6		W
	Class AB mode		2.6		W
SPKVDD Leakage Current	SPKVDD = 5.0V		0.15	1	μA
Line Output Programmable Gain Amplifier					
Minimum Gain			-57		dB
Maximum Gain			+6		dB
Gain Step Size			1		dB
Mute Attenuation		80	92		dB
Speaker Output Programmable Gain Amplifier					
Minimum Gain			-57		dB
Maximum Gain			+6		dB
Gain Step Size			1		dB
Mute Attenuation		80	92		dB
DAC Digital					
DAC maximum volume			0		dB
DAC minimum volume			-71.625		dB
DAC volume step size			0.375		dB
DAC soft mute time (Note: Scales linearly with sample rate) 0dBFS to mute	DAC_MUTERATE = 0		10.7		ms
	DAC_MUTERATE = 1		171		ms

ANALOGUE REFERENCE LEVELS

PARAMETER	TEST CONDITIONS	MIN	TYP	MAX	EV
Reference Voltages					
VMID Midrail Reference Voltage		-3%	AVDD/2	+3%	V

ANALOGUE INPUTS (IN1, IN2)

PARAMETER	TEST CONDITIONS	MIN	TYP	MAX	UNIT
Maximum Input Signal Level				AVDD/3.3	Vrms
IN1 Input resistance	0dB PGA gain		25		kΩ
	-6dB PGA gain		50		kΩ
IN2 Input resistance	0dB PGA gain		25		kΩ
	-6dB PGA gain		50		kΩ

DIGITAL INTERFACES

PARAMETER	TEST CONDITIONS	MIN	TYP	MAX	UNIT
Digital Input / Output					
Input HIGH Level		0.7× DBVDD			V
Input LOW Level				0.3× DBVDD	V
Output HIGH Level	I _{OL} =1mA	0.9× DBVDD			V
Output LOW Level	I _{OH} =-1mA			0.1× DBVDD	V
Input Capacitance			10		pF
Input Leakage		-0.5		0.5	μA

CLOCKING AND TIMING

PARAMETER	TEST CONDITIONS	MIN	TYP	MAX	UNIT
FLL					
Input Frequency		8kHz		27MHz	
Lock time				TBA	Reference Clock Periods
MCLK					
Input Frequency				25.000	MHz
CLK_SYS					
Frequency				12.500	MHz
Power-up and Power-down Sequences					
Power-up Time	Hardware mode		42		ms
	Software mode		42		ms
Power-down Time	Hardware mode		48		ms
	Software mode		48		ms

TYPICAL POWER CONSUMPTION

The WM9081 power consumption is dependent on many parameters. Most significantly, it depends on supply voltages, sample rates, mode of operation, and output loading.

The power consumption on each supply rail varies approximately with the square of the voltage. Power consumption is greater at fast sample rates than at slower ones. When the digital audio interface is operating in Master mode, the DBVDD current is significantly greater than in Slave mode. The output load conditions (impedance, capacitance and inductance) can also impact significantly on the device power consumption.

COMMON TEST CONDITIONS

Unless otherwise stated, the following test conditions apply throughout the following sections:

- Ambient temperature = +25°C
- Audio signal = quiescent (zero amplitude)
- Sample rate = 48kHz
- MCLK = 12.288MHz
- Audio interface mode = slave
- Control mode: software

Additional, variant test conditions are quoted within the relevant sections below. Where applicable, power dissipated in the speaker or line loads is included.

POWER CONSUMPTION MEASUREMENTS

Off and Standby modes									
Test conditions:									
<ul style="list-style-type: none"> • No clocks applied unless stated • No signal applied unless stated 									
Variant test conditions	AVDD		DCVDD		DBVDD		SPKVDD		TOTAL
	V	mA	V	mA	V	mA	V	mA	mW
Off (default settings)	3.3	0.05	1.8	0.01	1.8	0.01	5.0	0.00	0.18
Off (default settings), DACDAT, MCLK, BCLK and LRCLK applied	3.3	0.05	1.8	0.01	1.8	0.01	5.0	0.00	0.18
Off (lowest power settings)	3.3	0.01	1.8	0.00	1.8	0.00	5.0	0.00	0.03

DAC to Speaker Playback - DAC input to SPKOUTP/SPKOUTN pins with 4.1Ω + 22μH load.									
Test conditions:									
<ul style="list-style-type: none"> • Slave mode, MCLK = 12.288MHz, LRCLK = 48kHz • Input signal: 0dBFS 1kHz sine wave 									
Variant test conditions	AVDD		DCVDD		DBVDD		SPKVDD		TOTAL
	V	mA	V	mA	V	mA	V	mA	mW
DAC to Class D Speaker Playback no signal	3.3	2.7	1.8	1.3	1.8	0.0	5.0	2.7	24.9
DAC to Class D Speaker Playback 0.5W	3.3	2.8	1.8	1.4	1.8	0.0	5.0	120.0	611.7
DAC to Class D Speaker Playback 1.0W	3.3	2.8	1.8	1.4	1.8	0.0	5.0	225.0	1136.7
DAC to Class D Speaker Playback 2.0W	3.3	2.8	1.8	1.4	1.8	0.0	5.0	435.0	2186.7

DAC to Lineout Playback - DAC input to LINEOUT pin with 10kΩ load.

Test conditions:

- Slave mode, MCLK = 12.288MHz, LRCLK = 48kHz
- Input signal: 0dBFS 1kHz sine wave

Variant test conditions	AVDD		DCVDD		DBVDD		SPKVDD		TOTAL
	V	mA	V	mA	V	mA	V	mA	mW
DAC to LINEOUT, no input signal	3.3	1.9	1.8	1.3	1.8	0.0	5.0	0.0	8.5
DAC to LINEOUT, 0dBFS input signal	3.3	1.9	1.8	1.4	1.8	0.0	5.0	0.0	9.0

TYPICAL PERFORMANCE DATA

Typical speaker driver THD+N performance is shown below for both 8Ω and 4Ω loads in Class D mode. Curves are shown for four typical SPKVDD supply voltage and gain combinations.

SPEAKER CLASS D INTO 4Ω + 10μH

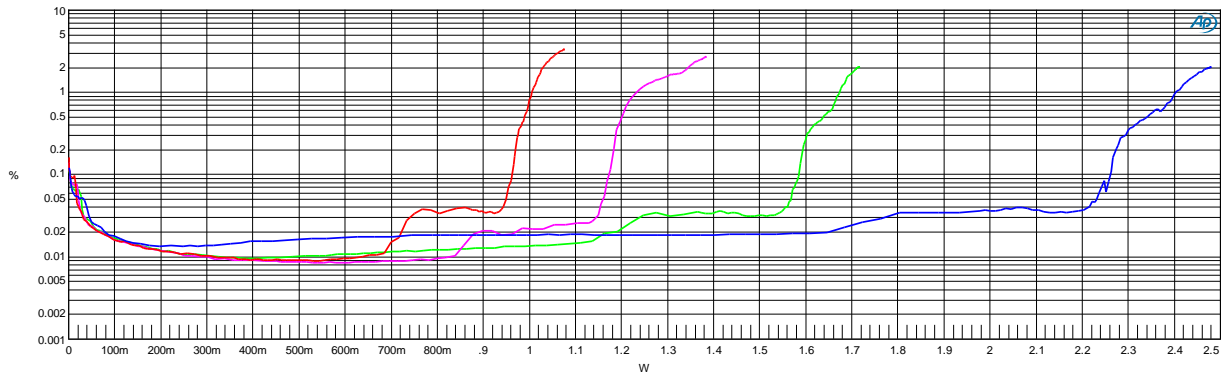

Sweep	Trace	Color	Line Style	Thick	Data	Axis	Comment
1	1	Blue	Solid	2	Anlr.TH+D+N Ratio	Left	SPKVDD = 5.0V, AVDD = 3.3V, DCGAIN = ACGAIN = 3.6dB
2	1	Green	Solid	2	Anlr.TH+D+N Ratio	Left	SPKVDD = 4.2V, AVDD = 3.3V, DCGAIN = ACGAIN = 2.1dB
3	1	Magenta	Solid	2	Anlr.TH+D+N Ratio	Left	SPKVDD = 3.7V, AVDD = 3.0V, DCGAIN = ACGAIN = 2.1dB
4	1	Red	Solid	2	Anlr.TH+D+N Ratio	Left	SPKVDD = 3.3V, AVDD = 3.3V, DCGAIN = ACGAIN = 0dB

Device: WM9081 MMC=WPF
 Input Signal: 1KHz; 0dBFS; 24-bit; 256fs (fs=48kHz)
 Output Path: SPK Class D
 Supplies: DBVDD=DCVDD=3.3V
 BW Filter: 22Hz to 20kHz AES17
 Additional Filtering: none
 Load = 4R1 + 10uH

SPEAKER CLASS D INTO 8Ω + 10μH

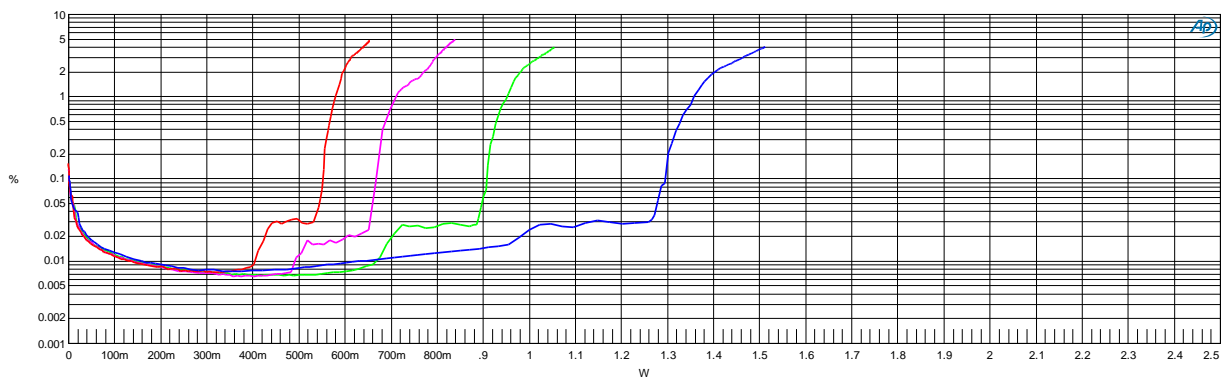

Sweep	Trace	Color	Line Style	Thick	Data	Axis	Comment
1	1	Blue	Solid	2	Anlr.TH+D+N Ratio	Left	SPKVDD = 5.0V, AVDD = 3.3V, DCGAIN = ACGAIN = 3.6dB
2	1	Green	Solid	2	Anlr.TH+D+N Ratio	Left	SPKVDD = 4.2V, AVDD = 3.3V, DCGAIN = ACGAIN = 2.1dB
3	1	Magenta	Solid	2	Anlr.TH+D+N Ratio	Left	SPKVDD = 3.7V, AVDD = 3.0V, DCGAIN = ACGAIN = 2.1dB
4	1	Red	Solid	2	Anlr.TH+D+N Ratio	Left	SPKVDD = 3.3V, AVDD = 3.3V, DCGAIN = ACGAIN = 0dB

Device: WM9081 MMC=WPF
 Input Signal: 1KHz; 0dBFS; 24-bit; 256fs (fs=48kHz)
 Output Path: SPK Class D
 Supplies: DBVDD=DCVDD=3.3V
 BW Filter: 22Hz to 20kHz AES17
 Additional Filtering: none
 Load = 8R2 + 10uH

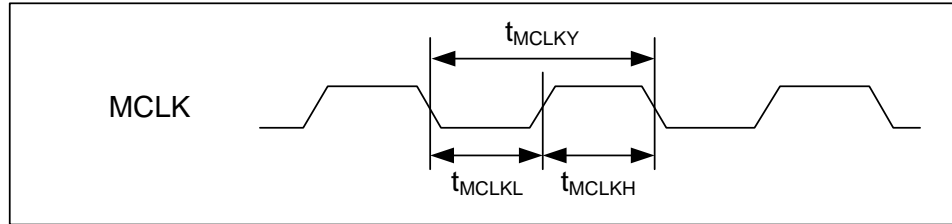
SIGNAL TIMING REQUIREMENTS
SYSTEM CLOCK TIMING

Figure 1 System Clock Timing Requirements
Test Conditions

 DCVDD=DBVDD=1.8V, AVDD=3.3V, SPKVDD=5V, DGND=AGND=SPKGND=0V, $T_A = +25^\circ\text{C}$

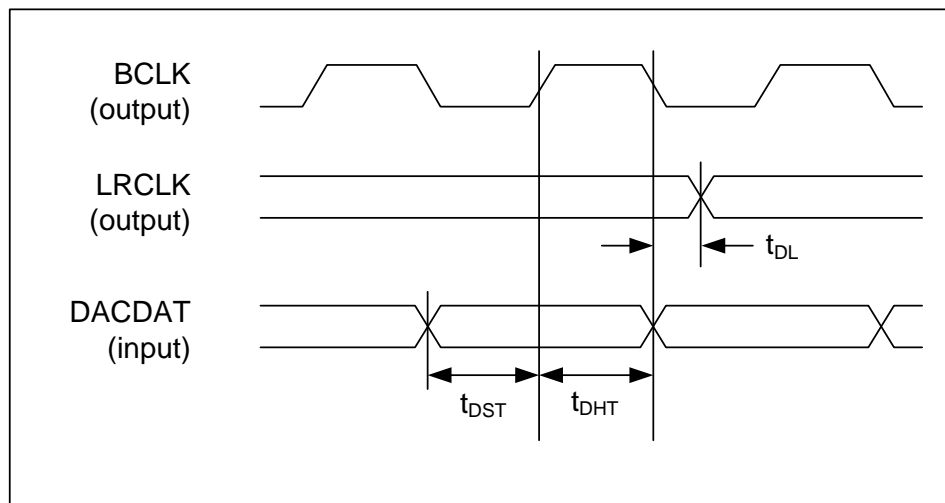
PARAMETER	SYMBOL	CONDITIONS	MIN	TYP	MAX	UNIT
System Clock Timing Information						
MCLK cycle time	T_{MCLKY}		40			ns
MCLK duty cycle		$= T_{MCLKH}/T_{MCLKL}$	60:40		40:60	

AUDIO INTERFACE TIMING – MASTER MODE

Figure 2 Digital Audio Data Timing - Master Mode
Test Conditions

DCVDD=DBVDD=1.8V, AVDD=3.3V, SPKVDD=5V, DGND=AGND=SPKGND=0V, $T_A=+25^{\circ}\text{C}$, Master Mode, $f_s=48\text{kHz}$, MCLK=256fs, 24-bit data, unless otherwise stated.

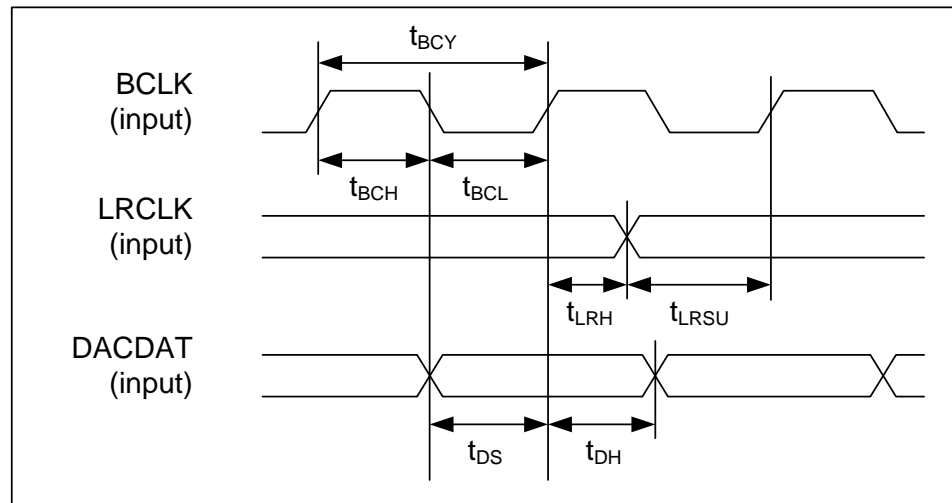
PARAMETER	SYMBOL	MIN	TYP	MAX	UNIT
Audio Data Timing Information					
LRCLK propagation delay from BCLK falling edge	t_{DL}			10	ns
DACDAT setup time to BCLK rising edge	t_{DST}	10			ns
DACDAT hold time from BCLK rising edge	t_{DHT}	10			ns

AUDIO INTERFACE TIMING – SLAVE MODE

Figure 3 Digital Audio Data Timing – Slave Mode
Test Conditions

DCVDD=DBVDD=1.8V, AVDD=3.3V, SPKVDD=5V, DGND=AGND=SPKGND=0V, T_A=+25°C, Slave Mode, fs=48kHz, MCLK=256fs, 24-bit data, unless otherwise stated.

PARAMETER	SYMBOL	MIN	TYP	MAX	UNIT
Audio Data Input Timing Information					
BCLK cycle time	t _{BCY}	80			ns
BCLK pulse width high	t _{BCH}	40			ns
BCLK pulse width low	t _{BCL}	40			ns
LRCLK set-up time to BCLK rising edge	t _{LRSU}	10			ns
LRCLK hold time from BCLK rising edge	t _{LRH}	10			ns
DACDAT hold time from BCLK rising edge	t _{DH}	10			ns
DACDAT set-up time to BCLK rising edge	t _{DS}	10			ns

Note:

BCLK period should always be greater than or equal to MCLK period.

CONTROL INTERFACE TIMING – 2-WIRE MODE

2-wire mode is selected by connecting the SWMODE pin high and connecting the SCIM_CHANNEL pin low.

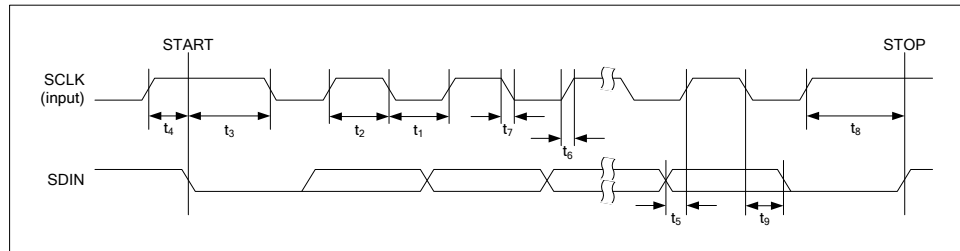

Figure 4 Control Interface Timing – 2-Wire Serial Control Mode

Test Conditions

DCVDD=DBVDD=1.8V, AVDD= 3.3V, SPKVDD=5V, DGND=AGND= SPKGND=0V, T_A=+25°C, Slave Mode, fs=48kHz, MCLK = 256fs, 24-bit data, unless otherwise stated.

PARAMETER	SYMBOL	MIN	TYP	MAX	UNIT
Program Register Input Information					
SCLK Frequency				526	kHz
SCLK Low Pulse-Width	t ₁	1.3			us
SCLK High Pulse-Width	t ₂	600			ns
Hold Time (Start Condition)	t ₃	600			ns
Setup Time (Start Condition)	t ₄	600			ns
Data Setup Time	t ₅	100			ns
SDIN, SCLK Rise Time	t ₆			300	ns
SDIN, SCLK Fall Time	t ₇			300	ns
Setup Time (Stop Condition)	t ₈	600			ns
Data Hold Time	t ₉			900	ns
Pulse width of spikes that will be suppressed	t _{ps}	0		5	ns

CONTROL INTERFACE TIMING – 3-WIRE MODE

3-wire mode is selected by connecting the SWMODE pin high and connecting the SCIM_CHANNEL pin high.

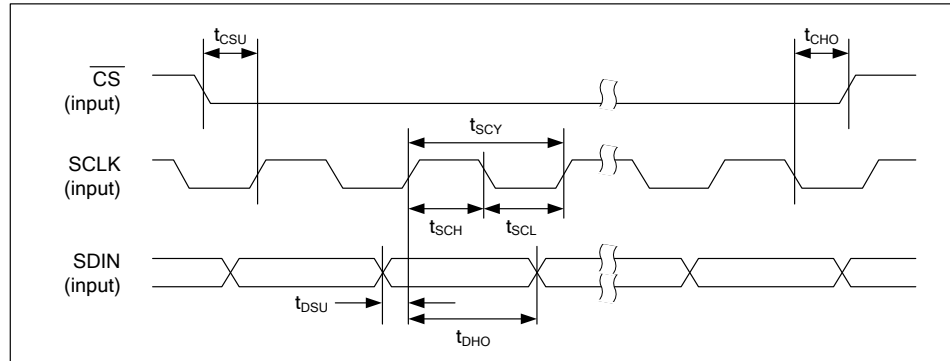

Figure 5 Control Interface Timing – 3-Wire Serial Control Mode (Write Cycle)

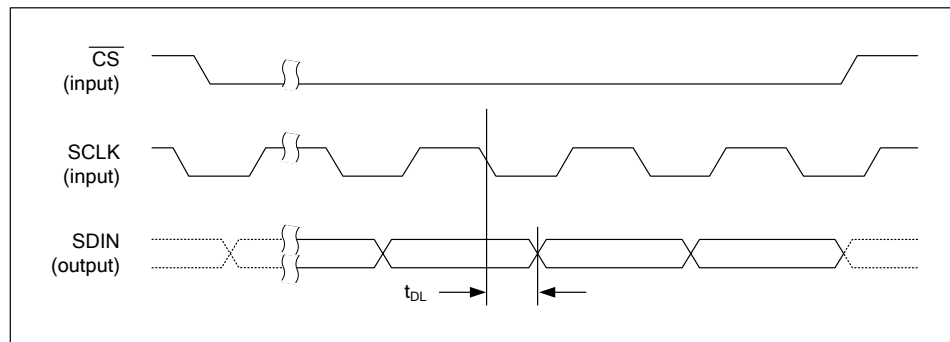

Figure 6 Control Interface Timing – 3-Wire Serial Control Mode (Read Cycle)

Test Conditions

DCVDD=DBVDD=1.8V, AVDD= 3.3V, SPKVDD=5V, DGND=AGND=SPKGND=0V, T_A=+25°C, Slave Mode, fs=48kHz, MCLK=256fs, 24-bit data, unless otherwise stated.

PARAMETER	SYMBOL	MIN	TYP	MAX	UNIT
Program Register Input Information					
CSB falling edge to SCLK rising edge	t _{CSU}	40			ns
SCLK rising edge to CSB rising edge	t _{CHO}	10			ns
SCLK pulse cycle time	t _{SCY}	160			ns
SCLK pulse width low	t _{SCL}	80			ns
SCLK pulse width high	t _{SCH}	80			ns
SDIN to SCLK set-up time	t _{DSU}	40			ns
SDIN to SCLK hold time	t _{DHO}	10			ns
Pulse width of spikes that will be suppressed	t _{ps}	0		5	ns
SCLK falling edge to SDOOUT transition	t _{DL}			40	ns

CONTROL INTERFACE TIMING – 4-WIRE MODE

4-wire mode supports readback via SDOUT.

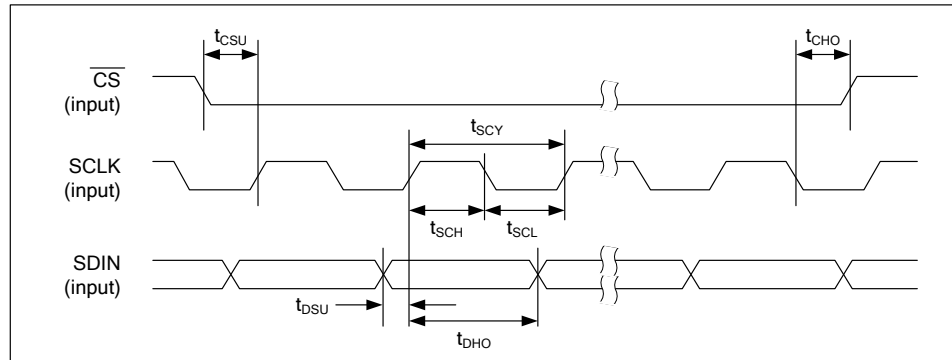
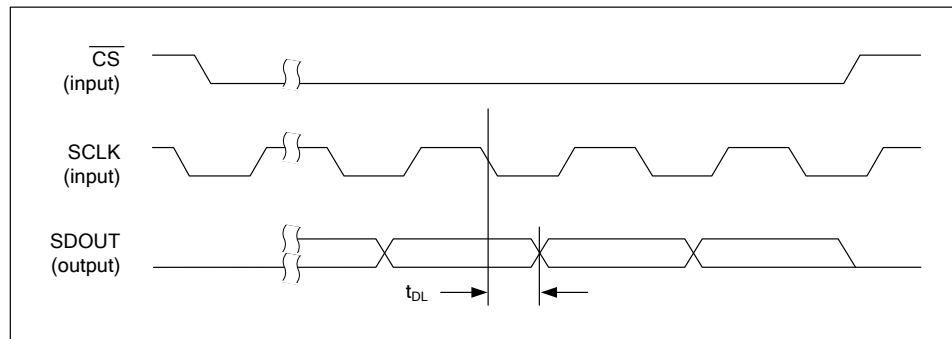
Figure 7 Control Interface Timing – 4-Wire Serial Control Mode (Write Cycle)

Figure 8 Control Interface Timing – 4-Wire Serial Control Mode (Read Cycle)
Test Conditions

 DCVDD=DBVDD=1.8V, AVDD= 3.3V, SPKVDD=5V, DGND=AGND=SPKGND=0V, T_A=+25°C, Slave Mode, fs=48kHz, MCLK=256fs, 24-bit data, unless otherwise stated.

PARAMETER	SYMBOL	MIN	TYP	MAX	UNIT
Program Register Input Information					
SCLK rising edge to CSB falling edge	t _{CSU}	40			ns
SCLK rising edge to CSB rising edge	t _{SHO}	40			ns
SCLK pulse cycle time	t _{SCY}	160			ns
SCLK pulse width low	t _{SCL}	80			ns
SCLK pulse width high	t _{SCH}	80			ns
SDIN to SCLK set-up time	t _{DSU}	40			ns
SDIN to SCLK hold time	t _{DHO}	10			ns
SDOUT propagation delay from SCLK rising edge	t _{DL}			10	ns
Pulse width of spikes that will be suppressed	t _{ps}	0		5	ns
SCLK falling edge to SDOUT transition	t _{DL}			40	ns

DEVICE DESCRIPTION

INTRODUCTION

The WM9081 is designed to provide high quality, high power output to a loudspeaker at low distortion levels in space-constrained portable applications. The device is well-suited to both mono and multi-channel speaker systems.

Digital input enables the power drivers to be located close to the speakers in multi-channel systems without the need for troublesome long analogue connections. Location of the power drivers close to the speakers also removes the need for bulky and expensive class D filters and reduces PCB track lengths, minimising emissions.

The WM9081 supports both hardware and software control modes.

In Hardware control modes, the digital audio interface format is fixed and either the left or right channel can be routed to the Class D speaker driver. The WM9081 is a slave device only on the audio interface; EQ and Dynamic Range Control functions are not supported.

In Software control modes, the digital audio interface is highly programmable. Ready-programmed control sequences can be commanded to enable/disable the speaker driver or line output. Programmable EQ and Dynamic Range Control is supported in the digital domain. Analogue audio input paths can also be mixed into the speaker or line output drivers. The speaker driver can be configured to operate either in Class AB or in Class D mode.

ReTune™ Mobile parametric EQ with fully programmable coefficients is integrated for optimization of speaker characteristics. A simple set-up mode is also available.

A programmable dynamic range controller is also available for maximizing loudness whilst also protecting speakers from being overdriven, preventing battery droop, waveform clipping, thermal overloads and premature system shutdown.

Figure 9 shows the DAC signal path and clocking architecture of the WM9081.

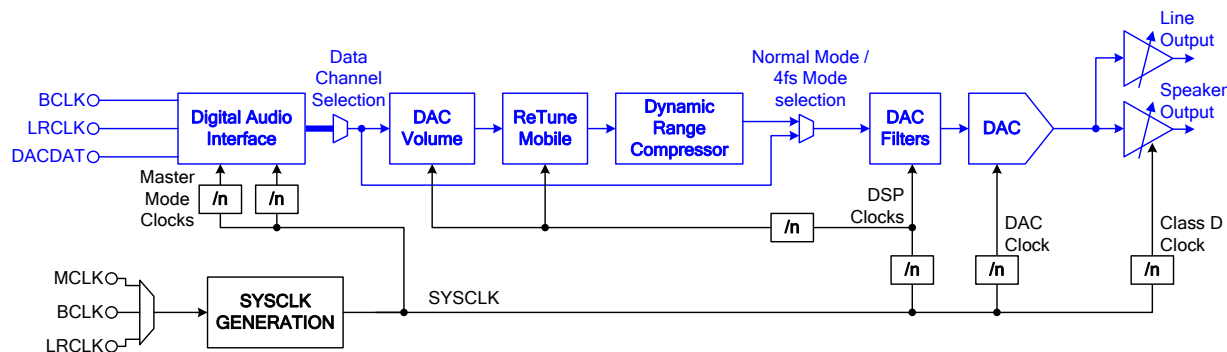

Figure 9 DAC Signal Path and Clocking Architecture

Digital audio transmission within the system also reduces crosstalk between, for example, microphone input signals and speaker output signals, enhancing stability and reducing the risk of 'howling' during speakerphone operation where very high microphone gain is used.

Four control interface addresses and four stereo TDM slots are supported to allow multiple WM9081 devices to be configured and driven independently.

CONTROL INTERFACE (SOFTWARE MODE)

The WM9081 can be controlled in hardware mode or in software modes. In hardware mode, the device is configured according to logic levels applied to hardware pins. In software mode, the device is configured using control register writes via a serial control interface. See “Control Interface (Hardware Mode)” for details of hardware control mode.

Software Control Mode is selected by logic 1 on the SWMODE pin. The logic level is referenced to the DBVDD power domain. When Software Mode is selected, the associated multi-function control pins are defined as described in Table 1.

PIN	DESCRIPTION
SCIM/CHANNEL	Software Control Interface Mode 0 = 2-wire 1 = 3-/4-wire
SDIN/ENA	Serial Data Input
SCLK	Serial Data Clock
SDOUT/ADDR0	2 wire mode - Device Address[0] 3-wire mode - Not used 4-wire mode - Serial Data Output
CS /ADDR1/4FS	2 wire mode - Device Address[1] 3-/4-wire mode - Chip Select

Table 1 Software Control Pin Configuration

A typical system configuration for software control mode is illustrated in Figure 10.

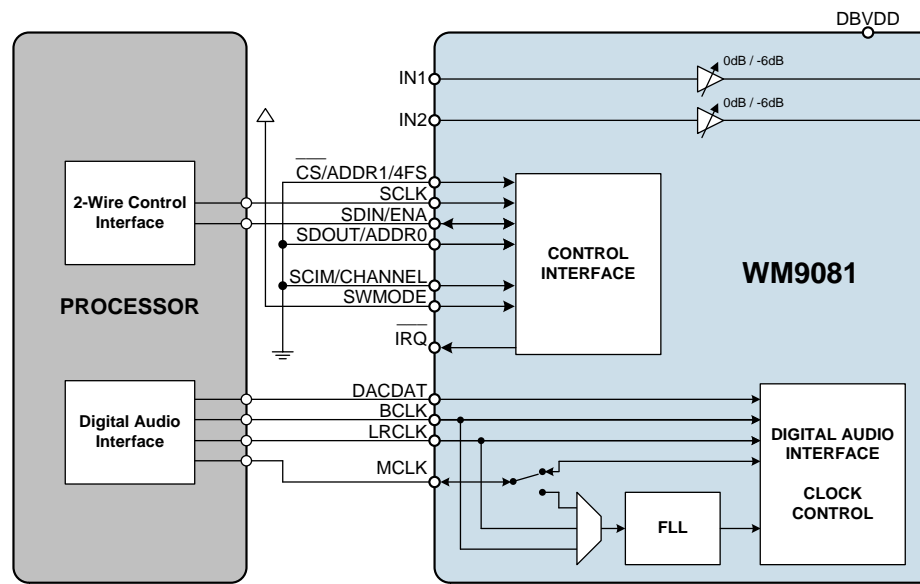

Figure 10 Software Control Mode Example – 2-Wire Control, Slave Mode, Device ID = D8h

In Software Control Mode, the WM9081 is controlled by writing to its control registers. Readback is available for all registers, including device ID and power management status bits. The control interface can operate as a 2-, 3- or 4-wire control interface: Readback is provided on the bi-directional pin SDIN in 2-wire and 3-wire modes. The WM9081 Software Control interface is supplied by the DBVDD power domain.

The available Software Control interface modes are summarised as follows:

- 2-wire mode uses pins SCLK and SDIN.
- 3-wire mode uses pins CS, SCLK and SDIN.
- 4-wire mode uses pins CS, SCLK, SDIN and SDOUT.

2-wire mode is selected by setting the SCIM/CHANNEL pin to logic 0. When this pin is set to logic 1, then 3-wire or 4-wire mode is selected according to the SPI_4WIRE register bit, as defined in Table 2.

In 4-wire mode, the electrical characteristics of the SDOUT pin are configurable using the SPI_CFG register bit.

ADDRESS	BIT	LABEL	DEFAULT	DESCRIPTION
R40 (28h) MW Slave 1	5	SPI_CFG	0	Controls the SDOUT pin in 4 wire mode 0 = SDOUT output is CMOS 1 = SDOUT output is open drain
	4	SPI_4WIRE	0	Selects 3-wire or 4-wire mode 0 = 3-wire mode using bi-directional SDIN pin 1 = 4-wire mode using SDOUT

Table 2 Software Control Mode Configuration

2-WIRE CONTROL MODE

In 2-wire mode, the WM9081 is a slave device on the control interface; SCLK is a clock input, while SDIN is a bi-directional data pin. To allow arbitration of multiple slaves (and/or multiple masters) on the same interface, the WM9081 transmits logic 1 by tri-stating the SDIN pin, rather than pulling it high. An external pull-up resistor is required to pull the SDIN line high so that the logic 1 can be recognised by the master.

In order to allow many devices to share a single 2-wire control bus, every device on the bus has a unique 7-bit device ID (this is not the same as the 8-bit address of each register in the WM9081). The device ID is determined by the logic level on the ADDR0 and ADDR1 pins as shown in Table 3. The LSB of the device ID is the Read/Write bit; this bit is set to logic 1 for “Read” and logic 0 for “Write”.

ADDR1	ADDR0	DEVICE ID
0	0	1101 1000 (D8h)
0	1	1101 1010 (DAh)
1	0	1101 1100 (DCh)
1	1	1101 1110 (DEh)

Table 3 Control Interface Device ID Selection

The WM9081 operates as a slave device only. The controller indicates the start of data transfer with a high to low transition on SDIN while SCLK remains high. This indicates that a device ID, register address and data will follow. All devices on the 2-wire bus respond to the start condition and shift in the next eight bits on SDIN (7-bit device ID + Read/Write bit, MSB first). If the device ID received matches the device ID of the WM9081, then the WM9081 responds by pulling SDIN low on the next clock pulse (ACK). If the device ID is not recognised or the R/W bit is ‘1’ when operating in write only mode, the WM9081 returns to the idle condition and waits for a new start condition and valid address.

If the device ID matches the device ID of the WM9081, the data transfer continues as described below. The controller indicates the end of data transfer with a low to high transition on SDIN while SCLK remains high. After receiving a complete address and data sequence the WM9081 returns to the idle state and waits for another start condition. If a start or stop condition is detected out of sequence at any point during data transfer (i.e. SDIN changes while SCLK is high), the device returns to the idle condition.

The WM9081 supports the following read and write operations:

- Single write
- Single read
- Multiple write using auto-increment
- Multiple read using auto-increment

The sequence of signals associated with a single register write operation is illustrated in Figure 11.

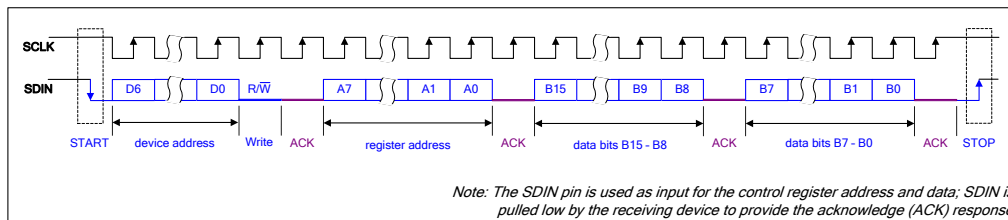

Figure 11 Control Interface 2-wire Register Write

The sequence of signals associated with a single register read operation is illustrated in Figure 12.

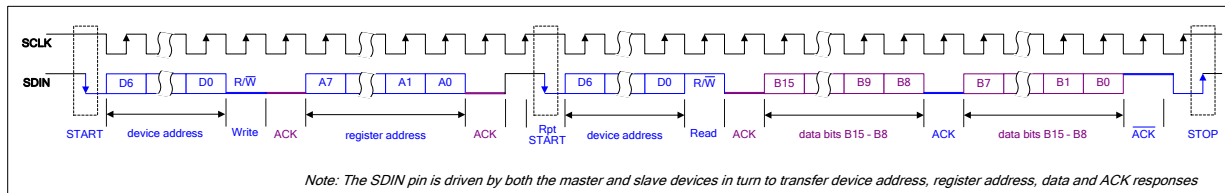

Figure 12 Control Interface 2-wire Register Read

The Control Interface also supports other register operations, as listed above. The interface protocol for these operations is summarised below. The terminology used in the following figures is detailed in Table 4.

Note that, for multiple write and multiple read operations, the auto-increment option must be enabled. This feature is enabled by default; it is described in Table 5 below.

TERMINOLOGY	DESCRIPTION
S	Start Condition
Sr	Repeated start
A	Acknowledge
P	Stop Condition
R/W	0 = Write 1 = Read
[White field]	Data flow from bus master to WM9081
[Grey field]	Data flow from WM9081 to bus master

Table 4 Control Interface Terminology



Figure 13 Single Register Write to Specified Address

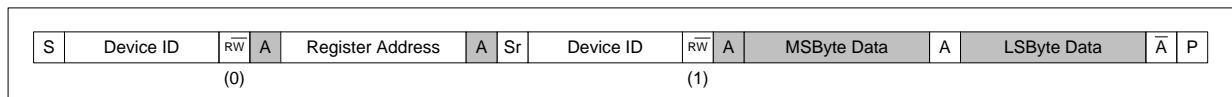

Figure 14 Single Register Read from Specified Address

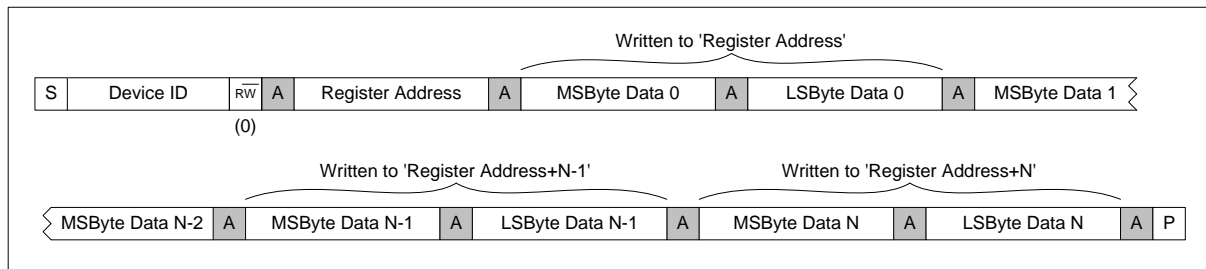

Figure 15 Multiple Register Write to Specified Address using Auto-increment

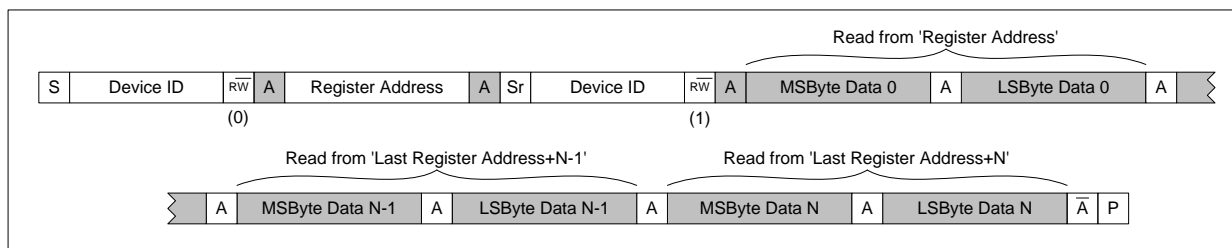

Figure 16 Multiple Register Read from Specified Address using Auto-increment

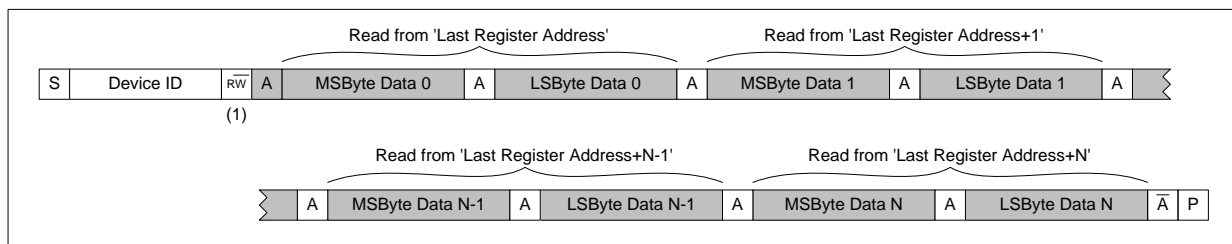

Figure 17 Multiple Register Read from Last Address using Auto-increment

Multiple Write and Multiple Read operations enable the host processor to access sequential blocks of the data in the WM9081 register map faster than is possible with single register operations. The auto-increment option is enabled when the AUTO_INC register bit is set. This bit is defined in Table 5. Auto-increment is enabled by default.

SMBUS Alert Response Address protocol is supported by the WM9081 when the ARA_ENA register bit is set. This function enables a bus controller to poll multiple devices on the I2C bus simultaneously in order to respond to Interrupt events efficiently. The WM9081 does not support automatic clearing of the SMBALERT# (implemented as IRQ on this device); a host device must service the alert and manually clear the IRQ status before proceeding to any other alerting devices in the system. The WM9081 device address used by this protocol is set as described in Table 5.

ADDRESS	BIT	LABEL	DEFAULT	DESCRIPTION
R40 (28h) MW Slave 1	3	ARA_ENA	0	Alert Response Address protocol enable 0 = Disabled 1 = Enabled
	1	AUTO_INC	1	Enable Auto-Increment function 0 = Disabled 1 = Enabled

Table 5 Auto-Increment and Alert Response Address Control

3-WIRE CONTROL MODE

The WM9081 is controlled by writing to registers through a 3-wire serial control interface. A control word consists of 24 bits. The first bit is the read/write bit (R/W), which is followed by 7 address bits (A6 to A0) that determine which control register is accessed. The remaining 16 bits (B15 to B0) are data bits, corresponding to the 16 bits in each control register.

In 3-wire mode, every rising edge of SCLK clocks in one data bit from the SDIN pin. A rising edge on CS latches in a complete control word consisting of the last 24 bits.

In Write operations (R/W=0), all SDIN bits are driven by the controlling device.

In Read operations (R/W=1), the SDIN pin is driven by the controlling device to clock in the register address, after which the WM9081 drives the SDIN pin to output the applicable data bits.

The 3-wire control mode timing is illustrated in Figure 18.

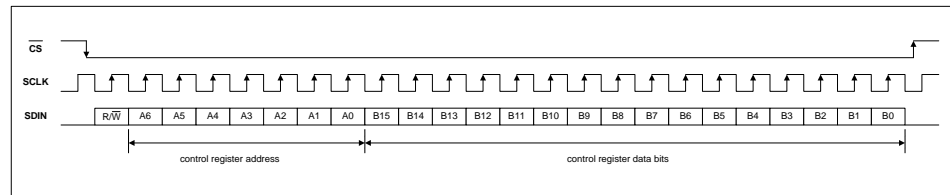

Figure 18 3-Wire Serial Control Interface

4-WIRE CONTROL MODE

In Write operations, this mode is the same as 3-wire Control Mode.

In Read operations, the SDIN pin is ignored following receipt of the valid register address. The data bits are output by the WM9081 on the SDOUT pin.

The SDOUT pin can be configured as CMOS or Open Drain, as described in Table 2. In CMOS mode, SDOUT is driven low when not outputting register data bits. In Open Drain mode, SDOUT is undriven when not outputting register data bits.

The 4-wire control mode timing is illustrated in Figure 19.

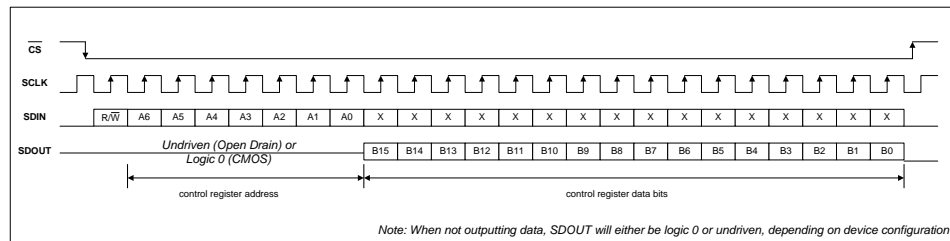
Figure 19 4-Wire Serial Control Interface

CONTROL INTERFACE (HARDWARE MODE)

The WM9081 can be controlled in hardware mode or in software modes. In hardware mode, the device is configured according to logic levels applied to hardware pins. In software mode, the device is configured using control register writes via a serial control interface. See “Control Interface (Software Mode)” for details of software control mode.

Hardware Control Mode selected by logic 0 on the SWMODE pin. The logic level is referenced to the DBVDD power domain. When Hardware Mode is selected, the associated multi-function control pins are defined as described in Table 7.

Note that two variants of Hardware Control Mode are supported; these are selected according to the logic level on the CS/ADDR1/4FS pin, as described in Table 7. In Normal mode, the WM9081 is clocked via a 12.288MHz input to the MCLK pin. In 4FS mode, the WM9081 is clocked via the BCLK pin. The selected channel of the received audio signal is routed to the Class D speaker output.

PIN	DESCRIPTION
SCIM/CHANNEL	Left/Right Channel select 0 = Left channel 1 = Right channel
SDIN/ENA	Device Enable (Normal mode) 0 = Disabled 1 = Enabled
SCLK	Not used
SDOUT/ADDR0	Not used
CS /ADDR1/4FS	4FS Mode select 0 = Normal 1 = 4FS Mode enabled

Table 6 Hardware Control Pin Configuration

A typical system configuration using hardware (normal) control is illustrated in Figure 20.

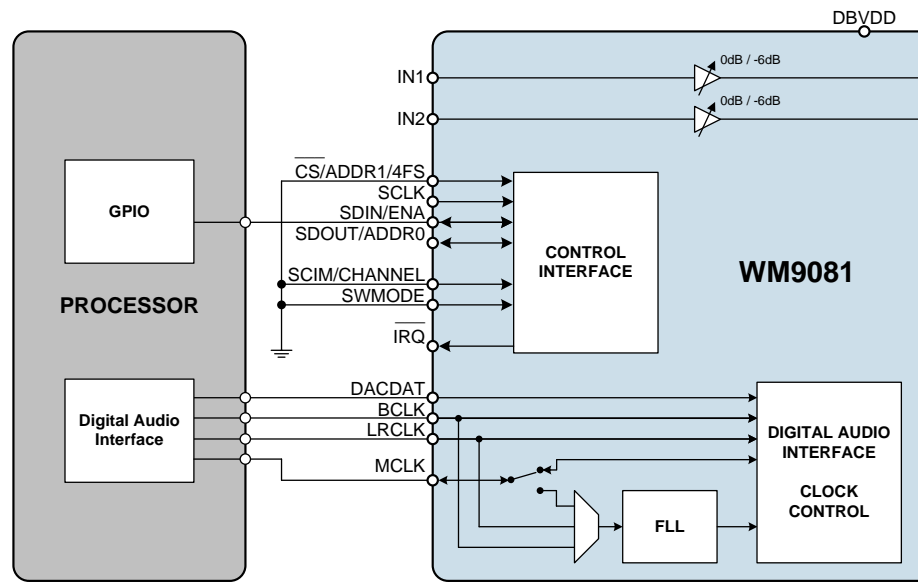

Figure 20 Hardware Control Mode Example – Normal Mode, Left Channel

A typical system configuration using 4FS mode is illustrated in Figure 21.

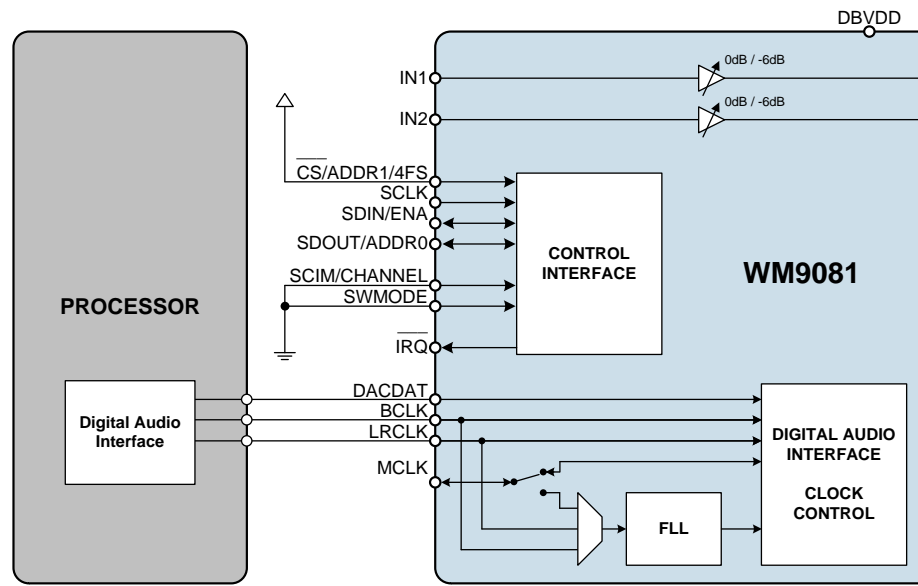

Figure 21 Hardware Control Mode Example – 4FS Mode, Left Channel

DEVICE ENABLE

The WM9081 is enabled by logic 1 on the SDIN/ENA pin. The logic level is referenced to the DBVDD power domain.

Note that in 4FS mode (see below), the WM9081 starts up and shuts down automatically according to the BCLK signal. In 4FS mode, the SDIN/ENA pin is ignored and may be set to either Logic 0 or Logic 1.

LEFT/RIGHT CHANNEL SELECT

The Left/Right channel selection is controlled using the SCIM/CHANNEL pin. The logic level is referenced to the DBVDD power domain. Logic 0 selects Left channel. Logic 1 selects Right channel.

The selected channel from the Digital Audio Interface will be applied to the Class D speaker output. It is recommended that the logic level on the SCIM/CHANNEL pin is not changed while the audio path of the WM9081 is enabled.

4FS MODE SELECT

The WM9081 supports two variants of Hardware Control mode. Normal mode is selected by a logic 0 on the CS/ADDR1/4FS pin. 4FS mode is selected by a logic 1 on the CS/ADDR1/4FS pin. The logic level is referenced to the DBVDD power domain. It is recommended that the logic level on the CS/ADDR1/4FS pin is not changed while the audio path of the WM9081 is enabled.

In Normal mode, the WM9081 is clocked via a 12.288MHz input to the MCLK pin. The digital audio interface is configured in 16-bit I²S format. The sample rate of the digital audio input must be 48kHz.

In 4FS mode, the WM9081 is clocked via the BCLK pin of the digital audio interface. The digital audio interface is configured in 16-bit I²S format. The sample rate of the digital audio input must be 4 x FS, where FS is the normal sample rate of 48kHz. It follows that the BCLK frequency is 6.144MHz. The integrated Frequency Locked Loop (FLL) is used to generate all the necessary internal clocks to operate the device from the BCLK input only.

In 4FS mode, the SDIN/ENA pin is not used as the Device Enable input. Instead, the WM9081 monitors the BCLK input and automatically powers up when BCLK is present and shuts down when BCLK is not present. This enables the WM9081 to operate autonomously with the minimum number of control signals.

HARDWARE CONTROL MODES SUMMARY

The WM9081 Hardware Control Modes are summarised in Table 7.

See “Digital Audio Interface” for more details of the I²S audio interface protocol.

CONFIGURATION	NORMAL MODE	4FS MODE
Audio interface data format	Stereo I ² S	Stereo I ² S
Word length	16	16
Data channel select	Selected by SCIM/CHANNEL	Selected by SCIM/CHANNEL
Master/Slave mode	Slave	Slave
TDM enabled	No	No
Clock input source	MCLK	BCLK
BCLK frequency	$\geq 32 \times \text{LRCLK}$	$32 \times \text{LRCLK}$
Automatic power-up / shut-down	Yes	Yes

Table 7 Hardware Control Modes Summary

Notes

1. MCLK must continue to run for 50ms after SDA/ENA is asserted low in order to shutdown the device.

CONTROL WRITE SEQUENCER

The Control Write Sequencer forms part of the WM9081 control interface logic. It provides the ability to perform a sequence of register write operations with the minimum of demands on the host processor - the sequence may be initiated by a single operation from the host processor and then left to execute independently.

Default sequences for controlling the Speaker and Lineout signal paths are provided (see “Default Sequences” section).

When a sequence is initiated, the sequencer performs a series of pre-defined register writes. The host processor informs the sequencer of the start index of the required sequence within the sequencer’s memory. At each step of the sequence, the contents of the selected register fields are read from the sequencer’s memory and copied into the WM9081 control registers. This continues sequentially through the sequencer’s memory until an “End of Sequence” bit is encountered; at this point, the sequencer stops and an Interrupt status flag is asserted. For cases where the timing of the write sequence is important, the sequencer is programmed with time delays for specific steps within the sequence.

Note that the Control Write Sequencer’s internal clock is derived from the internal clock CLK_SYS which must be enabled by setting CLK_SYS_ENA (see “Clocking and Sample Rates”). The clock division from CLK_SYS is handled transparently by the WM9081 without user intervention, provided that the CLK_SYS and sample rate control fields are set correctly.

INITIATING A SEQUENCE

The Register fields associated with running the Control Write Sequencer are described in Table 8. Note that the operation of the Control Write Sequencer also requires the internal clock CLK_SYS to be enabled via the CLK_SYS_ENA (see “Clocking and Sample Rates”).

The Write Sequencer is enabled by setting the WSEQ_ENA bit. The start index of the required sequence must be written to the WSEQ_START_INDEX field. Setting the WSEQ_START bit initiates the sequencer at the given start index.

The Write Sequencer can be interrupted by writing a logic 1 to the WSEQ_ABORT bit.

The current status of the Write Sequencer can be read using two further register fields - when the WSEQ_BUSY bit is asserted, this indicates that the Write Sequencer is busy. Note that, whilst the Control Write Sequencer is running a sequence (indicated by the WSEQ_BUSY bit), normal read/write operations to the Control Registers cannot be supported. The index of the current step in the Write Sequencer can be read from the WSEQ_CURRENT_INDEX field; this is an indicator of the sequencer’s progress. On completion of a sequence, this field holds the index of the last step within the last commanded sequence.

When the Write Sequencer reaches the end of a sequence, it asserts the WSEQ_BUSY_EINT flag in Register R26 (1Ah). (Note that the WSEQ_BUSY_EINT flag is asserted to indicate that the WSEQ is NOT busy.) This flag can be used to generate an Interrupt Event on completion of the sequence; this is indicated via the IRQ pin. See “Interrupts” for details of hardware output of the Write Sequencer status via the IRQ pin.

REGISTER ADDRESS	BIT	LABEL	DEFAULT	DESCRIPTION
R38 (26h) Write Sequencer 0	15	WSEQ_ENA	0	Write Sequencer Enable. 0 = Disabled 1 = Enabled
	9	WSEQ_ABORT	0	Writing a 1 to this bit aborts the current sequence and returns control of the device back to the serial control interface.

REGISTER ADDRESS	BIT	LABEL	DEFAULT	DESCRIPTION
	8	WSEQ_START	0	Writing a 1 to this bit starts the write sequencer at the memory location indicated by the WSEQ_START_INDEX field. The sequence continues until it reaches an "End of sequence" flag. At the end of the sequence, this bit will be reset by the Write Sequencer.
	6:0	WSEQ_START_INDEX [6:0]	000_0000	Sequence Start Index. This is the memory location of the first command in the selected sequence.
R39 (27h) Write Sequencer 1	10:4	WSEQ_CURRENT_INDEX [6:0] (read only)	000_0000	Sequence Current Index. This is the location of the most recently accessed command in the write sequencer memory.
	0	WSEQ_BUSY (read only)	0	Sequencer Busy flag (Read Only). 0 = Sequencer idle 1 = Sequencer busy Note: it is not possible to write to control registers via the control interface while the Sequencer is Busy.

Table 8 Write Sequencer Control

DEFAULT SEQUENCES

When the WM9081 is powered up, a number of default Control Write Sequences are available in non-volatile memory. The pre-programmed default settings include Start-Up and Shut-Down sequences for each of the output drivers. Note that the internal clock, CLK_SYS, must be enabled in order to run these sequences.

The following default control sequences are provided:

1. Class D Speaker Enable Sequence

Class D Speaker Enable - This sequence powers up the speaker driver in Class D mode, and enables the DAC signal path. The soft-start VMID circuit is selected as part of this sequence. On completion, the Lineout is clamped to VMID.

The Class D Speaker Enable sequence is initiated by writing 8100h to Register 38 (26h). This single operation starts the Control Write Sequencer at Index Address 0 (00h). For typical clocking configurations, this sequence takes approximately 42ms to run.

Note that this sequence is optimized for pop suppression on the Speaker output. For pop suppression on the Line Output, please refer to sequence 3.

2. Class D Speaker Disable Sequence

Class D Speaker Disable - This sequence powers down the Class D speaker driver. As part of this sequence, the DAC is muted and disabled, the Lineout is discharged to AGND and the reference/bias circuits are disabled. This sequence is applicable to the Class D speaker mode.

The Class D Speaker Disable sequence is initiated by writing 8115h to Register 38 (26h). This single operation starts the Control Write Sequencer at Index Address 21 (15h). For typical clocking configurations, this sequence takes approximately 48ms to run.

3. Lineout Enable Sequence

Lineout Enable - This sequence powers up the lineout, and enables the DAC signal path. The lineout is discharged initially, and the soft-start VMID circuit is used to suppress pops during power-up.

The Lineout Enable sequence is initiated by writing 812Ah to Register 38 (26h). This single operation starts the Control Write Sequencer at Index Address 42 (2Ah). For typical clocking configurations, this sequence takes approximately 550ms to run.

4. Lineout Disable Sequence

Lineout Disable - This sequence powers down the lineout. As part of this sequence, the DAC is muted and disabled, the Lineout is discharged to AGND and the reference/bias circuits are disabled.

The Lineout disable sequence is initiated by writing 813Fh to Register 38 (26h). This single operation starts the Control Write Sequencer at Index Address 63 (3Fh). For typical clocking configurations, this sequence takes approximately 646ms to run.

5. Class AB Speaker Enable Sequence

Class AB Speaker Enable - This sequence powers up the speaker driver in Class AB mode, and enables the DAC signal path. The soft-start VMID circuit is selected as part of this sequence. On completion, the Lineout is clamped to VMID.

The Class AB Speaker Enable sequence is initiated by writing 8154h to Register 38 (26h). This single operation starts the Control Write Sequencer at Index Address 84 (54h). For typical clocking configurations, this sequence takes approximately 42ms to run.

Note that this sequence is optimized for pop suppression on the Speaker output. For pop suppression on the Line Output, please refer to sequence 3.

6. Class AB Speaker Disable Sequence

Class AB Speaker Disable - This sequence powers down the Class AB speaker driver. As part of this sequence, the DAC is muted and disabled, the Lineout is discharged to AGND and the reference/bias circuits are disabled.

The Class AB Speaker Disable sequence is initiated by writing 8169h to Register 38 (26h). This single operation starts the Control Write Sequencer at Index Address 105 (69h). For typical clocking configurations, this sequence takes approximately 49ms to run.

Notes

1. For details on the Control Write Sequencer default sequences, refer to the application note WAN_0204 'WM9081 Control Write Sequencer default sequences'.

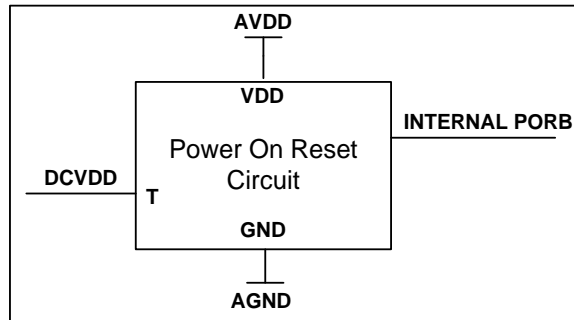
POWER ON RESET CIRCUIT

Figure 22 Internal Power on Reset Circuit Schematic

The WM9081 includes an internal CODEC Power-On-Reset Circuit, as shown in Figure 22, which is used to reset the CODEC digital logic into a default state after power up. The CODEC POR circuit is powered from AVDD and monitors DCVDD. It asserts PORB low if AVDD or DCVDD is below a minimum threshold.

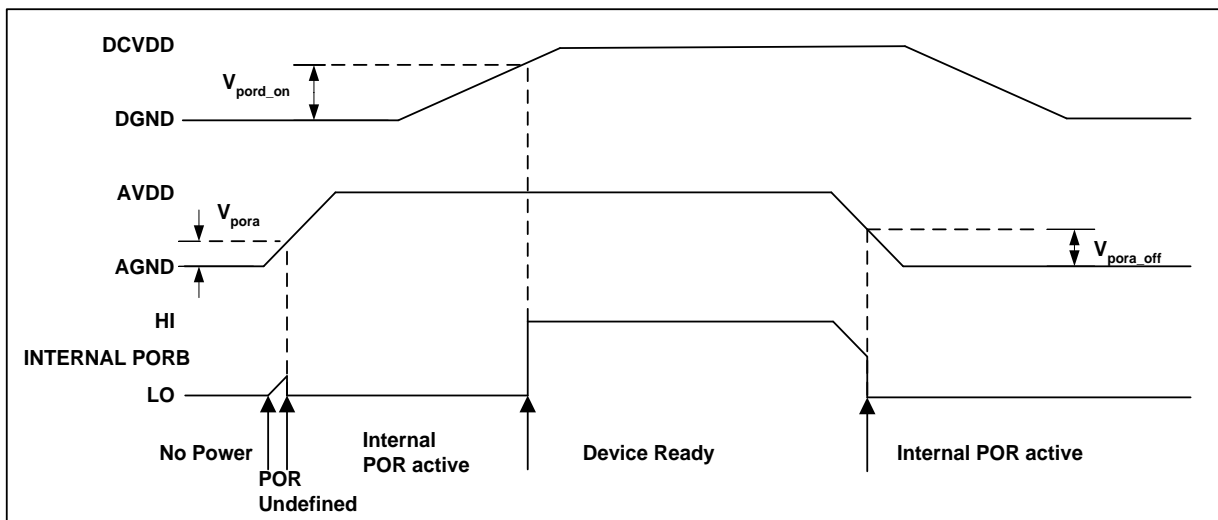

Figure 23 Typical CODEC Power up Sequence where AVDD is Powered before DCVDD

Figure 23 shows a typical power-up sequence where AVDD comes up first. When AVDD goes above the minimum threshold, V_{pora} , there is enough voltage for the circuit to guarantee PORB is asserted low and the chip is held in reset. In this condition, all writes to the control interface are ignored. After AVDD has reached its full supply level, DCVDD rises to V_{pord_on} and PORB is released high and all registers are in their default state and writes to the control interface may take place.

On power down, where AVDD falls first, PORB is asserted low whenever AVDD drops below the minimum threshold V_{pora_off} .

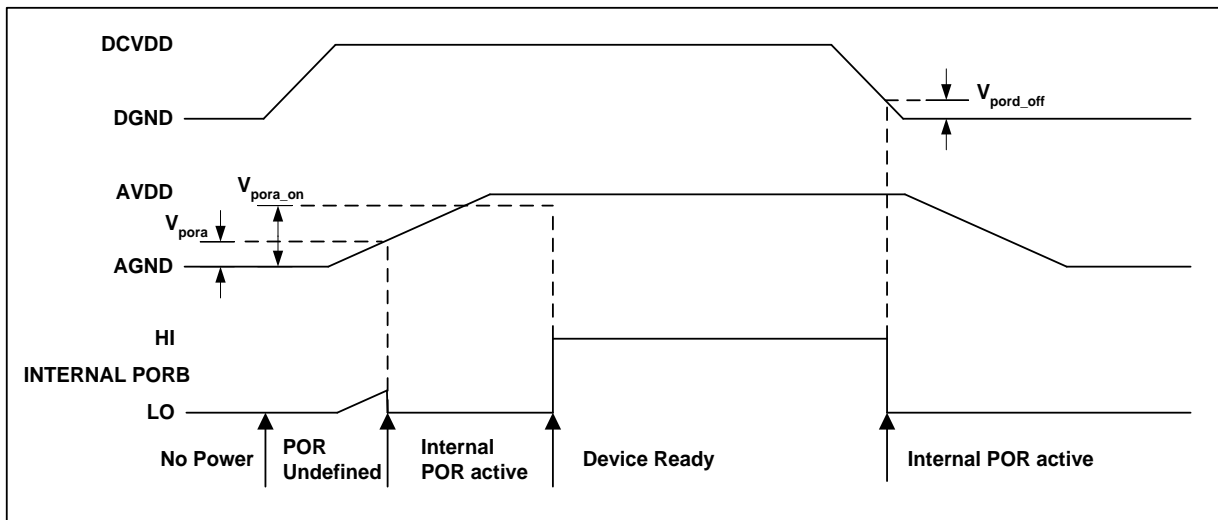

Figure 24 Typical Power up Sequence where DCVDD is Powered before AVDD

Figure 24 shows a typical power-up sequence where DCVDD comes up first. First it is assumed that DCVDD is already up to specified operating voltage. When AVDD goes above the minimum threshold, V_{pora} , there is enough voltage for the circuit to guarantee PORB is asserted low and the chip is held in reset. In this condition, all writes to the control interface are ignored. When AVDD rises to V_{pora_on} , PORB is released high and all registers are in their default state and writes to the control interface may take place.

On power down, where DCVDD falls first, PORB is asserted low whenever DCVDD drops below the minimum threshold V_{pord_off} .

SYMBOL	MIN	TYP	MAX	UNIT
V_{pora}		0.6		V
V_{pora_on}		1.46		V
V_{pora_off}		1.44		V
V_{pord_on}		0.91		V
V_{pord_off}		0.90		V

Table 9 Typical POR Operation at typical supply voltages

Notes

1. If AVDD and DCVDD suffer a brown-out (i.e. drop below the minimum recommended operating level but do not go below V_{pora_off} or V_{pord_off}) then the chip will not reset and will resume normal operation when the voltage is back to the recommended level again.
2. The chip will enter reset at power down when AVDD or DCVDD falls below V_{pora_off} or V_{pord_off} . This may be important if the supply is turned on and off frequently by a power management system.
3. The minimum t_{por} period is maintained even if DCVDD and AVDD have zero rise time. This specification is guaranteed by design rather than test.
4. V_{pora} is a simulated value

DYNAMIC RANGE CONTROLLER (DRC)

The dynamic range controller (DRC) is a circuit which can be enabled in the digital data path of the WM9081. The function of the DRC is to adjust the signal gain in conditions where the input amplitude is unknown or varies over a wide range. The DRC can apply Compression and Automatic Level Control to the signal path. It incorporates 'anti-clip' and 'quick release' features for handling transients in order to improve intelligibility in the presence of loud impulsive noises.

Using the DRC to normalise the audio signal level can also provide protection from excessive output power conditions, which can lead to battery droop, increased heat dissipation and over-temperature system shutdown.

The DRC is enabled as shown in Table 10. Note that the DRC is not available in hardware control mode.

REGISTER ADDRESS	BIT	LABEL	DEFAULT	DESCRIPTION
R32 (20h) DRC 1	15	DRC_ENA	0	DRC enable 0 = Disabled 1 = Enabled

Table 10 DRC Enable

COMPRESSION/LIMITING CAPABILITIES

The DRC supports two different compression regions, separated by a 'knee' at a specific input amplitude. In the region above the knee, the compression slope DRC_HI_COMP applies; in the region below the knee, the compression slope DRC_LO_COMP applies.

The overall DRC compression characteristic in 'steady state' (i.e. where the input amplitude is near-constant) is illustrated in Figure 25.

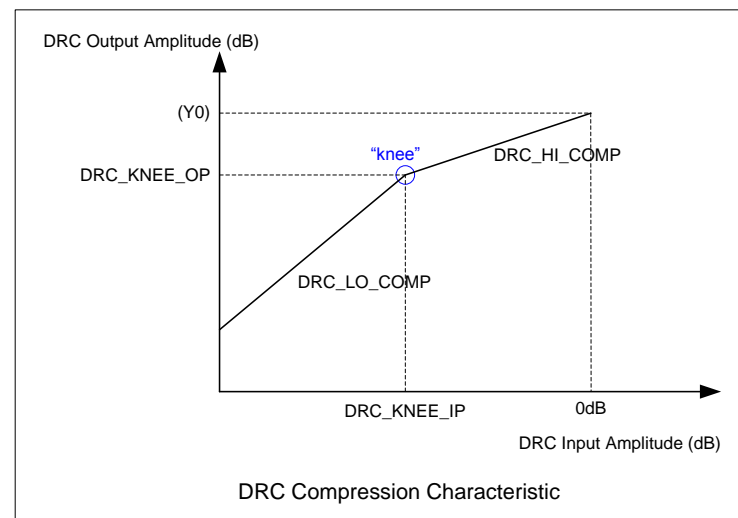

Figure 25 DRC Compression Characteristic

The slope of the DRC response is determined by register fields DRC_HI_COMP and DRC_LO_COMP. A slope of 1 indicates constant gain in this region. A slope less than 1 represents compression (i.e. a change in input amplitude produces only a smaller change in output amplitude). A slope of 0 indicates that the target output amplitude is the same across a range of input amplitudes; this is infinite compression.

The DRC Compression parameters are listed in Table 11.

PARAMETER	DESCRIPTION
DRC_KNEE_IP	Input level at the knee (dB)
DRC_KNEE_OP	Output level at the knee (dB)
DRC_HI_COMP	Compression ratio above knee
DRC_LO_COMP	Compression ratio below knee

Table 11 DRC Compression Parameters

The knee Figure 25 is defined by register fields DRC_KNEE_IP and DRC_KNEE_OP respectively.

Parameter Y0, the output level for a 0dB input, is not specified directly, but can be calculated from the other parameters, using the equation:

$$Y0 = DRC_KNEE_OP - (DRC_KNEE_IP * DRC_HI_COMP)$$

The registers which control the DRC Compression parameters are shown in Table 12.

REGISTER ADDRESS	BIT	LABEL	DEFAULT	DESCRIPTION
R34 (22h) DRC 3	5:3	DRC_HI_COMP [2:0]	000	Compressor slope (upper region) 000 = 1 (no compression) 001 = 1/2 010 = 1/4 011 = 1/8 100 = 1/16 101 = 0 110 = Reserved 111 = Reserved
	2:0	DRC_LO_COMP [2:0]	000	Compressor slope (lower region) 000 = 1 (no compression) 001 = 1/2 010 = 1/4 011 = 1/8 100 = 0 101 = Reserved 11X = Reserved
R35 (23h) DRC 4	10:5	DRC_KNEE_IP [5:0]	00_0000	Input signal level at the Compressor 'knee'. 000000 = 0dB 000001 = -0.75dB 000010 = -1.5dB ... (-0.75dB steps) 111100 = -45dB 111101 = Reserved 11111X = Reserved
	4:0	DRC_KNEE_OP [4:0]	0_0000	Output signal at the Compressor 'knee'. 00000 = 0dB 00001 = -0.75dB 00010 = -1.5dB ... (-0.75dB steps) 11110 = -22.5dB 11111 = Reserved

Table 12 DRC Compression Control

GAIN LIMITS

The minimum and maximum gain applied by the DRC is set by register fields DRC_MINGAIN and DRC_MAXGAIN. These limits can be used to alter the DRC response from that illustrated in Table 13. If the range between maximum and minimum gain is reduced, then the extent of the dynamic range control is reduced. The maximum gain prevents quiet signals (or silence) from being excessively amplified.

REGISTER ADDRESS	BIT	LABEL	DEFAULT	DESCRIPTION
R33 (21h) DRC 2	3:2	DRC_MINGAIN[1:0]	00	Minimum gain the DRC can use to attenuate audio signals 00 = 0dB (default) 01 = -6dB 10 = -12dB 11 = -18dB
	1:0	DRC_MAXGAIN[1:0]	00	Maximum gain the DRC can use to boost audio signals 00 = 12dB 01 = 18dB (default) 10 = 24dB 11 = 36dB

Table 13 DRC Gain Limits
DYNAMIC CHARACTERISTICS

The dynamic behaviour determines how quickly the DRC responds to changing signal levels. Note that the DRC responds to the average (RMS) signal amplitude over a period of time.

The DRC_ATK register determines how quickly the DRC gain decreases when the signal amplitude is high. The DRC_DCY register determines how quickly the DRC gain increases when the signal amplitude is low.

These register fields are described in Table 14. Note that the register defaults are suitable for general purpose use.

REGISTER ADDRESS	BIT	LABEL	DEFAULT	DESCRIPTION
R33 (21h) DRC 2	15:12	DRC_ATK[3:0]	0000	Gain attack rate (seconds/6dB) 0000 = Reserved (181us) 0001 = 181us 0010 = 363us 0011 = 726us 0100 = 1.45ms (default) 0101 = 2.9ms 0110 = 5.8ms 0111 = 11.6ms 1000 = 23.2ms 1001 = 46.4ms 1010 = 92.8ms 1011 = 185.6ms 1100-1111 = Reserved

REGISTER ADDRESS	BIT	LABEL	DEFAULT	DESCRIPTION
	11:8	DRC_DCY[3:0]	0000	Gain decay rate (seconds/6dB) 0000 = 186ms 0001 = 372ms 0010 = 743ms (default) 0011 = 1.49s 0100 = 2.97s 0101 = 5.94s 0110 = 11.89s 0111 = 23.78s 1000 = 47.56s 1001-1111 = Reserved

Table 14 DRC Time Constants

ANTI-CLIP CONTROL

The DRC includes an Anti-Clip feature to avoid signal clipping when the input amplitude rises very quickly. This feature uses a feed-forward technique for early detection of a rising signal level. Signal clipping is avoided by dynamically increasing the gain attack rate when required. The Anti-Clip feature is enabled using the DRC_ANTICLIP bit.

Note that the feed-forward processing increases the latency in the input signal path. For low-latency applications (e.g. telephony), it may be desirable to reduce the delay, although this will also reduce the effectiveness of the anti-clip feature. The latency is determined by the DRC_FF_DLY bit. If necessary, the latency can be minimised by disabling the anti-clip feature altogether.

The DRC Anti-Clip control bits are described in Table 15.

REGISTER ADDRESS	BIT	LABEL	DEFAULT	DESCRIPTION
R32 (20h) DRC 1	5	DRC_FF_DLY	1	Feed-forward delay for anti-clip feature 0 = 5 samples 1 = 9 samples Time delay can be calculated as $5/f_s$ or $9/f_s$, where f_s is the sample rate.
	1	DRC_ANTICLIP	1	Anti-clip enable 0 = Disabled 1 = Enabled

Table 15 DRC Anti-Clip Control

Note that the Anti-Clip feature operates entirely in the digital domain, i.e. on the input path to the DAC. It cannot be used to prevent signal clipping in the analogue domain (e.g. in the output PGA), nor in the source signal. Analogue clipping can only be prevented by reducing the analogue signal gain or by adjusting the source signal.

QUICK RELEASE CONTROL

The DRC includes a Quick-Release feature to handle short transient peaks that are not related to the intended source signal. The Quick Release feature ensures that these transients do not cause the intended signal to be masked by the longer time constants of DRC_DCY.

The Quick-Release feature is enabled by setting the DRC_QR bit. When this bit is enabled, the DRC measures the crest factor (peak to RMS ratio) of the input signal. A high crest factor is indicative of a transient peak that may not be related to the intended source signal. If the crest factor exceeds the level set by DRC_QR_THR, then the normal decay rate (DRC_DCY) is ignored and a faster decay rate (DRC_QR_DCY) is used instead.

The DRC Quick-Release control bits are described in Table 16.

REGISTER ADDRESS	BIT	LABEL	DEFAULT	DESCRIPTION
R32 (20h) DRC 1	2	DRC_QR	1	Quick release enable 0 = Disabled 1 = Enabled
R33 (21h) DRC 2	7:6	DRC_QR_THR [1:0]	00	Quick release crest factor threshold 00 = 12dB (default) 01 = 18dB 10 = 24dB 11 = 30dB
	5:4	DRC_QR_DCY [1:0]	00	Quick release decay rate (seconds/6dB) 00 = 0.725ms (default) 01 = 1.45ms 10 = 5.8ms 11 = Reserved

Table 16 DRC Quick-Release Control

INITIALISATION

When the DRC is initialised, the gain is set to the level determined by the DRC_STARTUP_GAIN register field. The default setting is 0dB, but values from -3dB to +6dB are available, as described in Table 17.

REGISTER ADDRESS	BIT	LABEL	DEFAULT	DESCRIPTION
R32 (20h) DRC 1	10:6	DRC_STARTUP_GAIN [4:0]	0_0110	Initial gain at DRC startup 00000 = -3dB 00001 = -2.5dB 00010 = -2dB 00011 = -1.5dB 00100 = -1dB 00101 = -0.5dB 00110 = 0dB (default) 00111 = 0.5dB 01000 = 1dB 01001 = 1.5dB 01010 = 2dB 01011 = 2.5dB 01100 = 3dB 01101 = 3.5dB 01110 = 4dB 01111 = 4.5dB 10000 = 5dB 10001 = 5.5dB 10010 = 6dB 10011 to 11111 = Reserved

Table 17 DRC Initialisation

RETUNE MOBILE PARAMETRIC EQUALIZER (EQ)

The ReTune™ Mobile Parametric EQ is a circuit which can be enabled in the DAC digital signal path. The function of the EQ is to adjust the frequency characteristic of the output in order to compensate for unwanted frequency characteristics in the loudspeaker (or other output transducer). It can also be used to tailor the response according to user preferences, for example to accentuate or attenuate specific frequency bands to emulate different sound profiles or environments e.g. concert hall, rock etc.

The EQ is enabled as shown in Table 18.

REGISTER ADDRESS	BIT	LABEL	DEFAULT	DESCRIPTION
R42 (2Ah) EQ1	0	EQ_ENA	0	EQ Enable 0 = Disabled 1 = Enabled

Table 18 ReTune Mobile Parametric EQ Enable

The EQ can be configured to operate in two modes - "Default" mode or "ReTune Mobile" mode.

DEFAULT MODE (5-BAND PARAMETRIC EQ)

In default mode, the cut-off / centre frequencies are fixed as per Table 19. The filter bandwidths are also fixed in default mode. The gain of the individual bands (-12dB to +12dB) can be controlled as described in Table 20. A full definition of the EQ Gain settings is provided in Table 21.

Note that the cut-off / centre frequencies noted in Table 19 are applicable to a DAC Sample Rate of 48kHz. When using other sample rates, these frequencies will be scaled in proportion to the selected sample rate.

EQ BAND	CUT-OFF/CENTRE FREQUENCY
1	100 Hz
2	300 Hz
3	875 Hz
4	2400 Hz
5	6900 Hz

Table 19 EQ Band Cut-off / Centre Frequencies

REGISTER ADDRESS	BIT	LABEL	DEFAULT	DESCRIPTION
R42 (2Ah) EQ1	15:11	EQ_B1_GAIN [4:0]	0_0000	EQ Band 1 Gain 00000 = -12dB 00001 = -11dB 11000 = +12dB
	10:6	EQ_B2_GAIN [4:0]	0_0000	EQ Band 2 Gain 00000 = -12dB 00001 = -11dB 11000 = +12dB
	5:1	EQ_B3_GAIN [4:0]	0_0000	EQ Band 3 Gain 00000 = -12dB 00001 = -11dB 11000 = +12dB
R43 (2Bh)	15:11	EQ_B4_GAIN	0_0000	EQ Band 4 Gain

REGISTER ADDRESS	BIT	LABEL	DEFAULT	DESCRIPTION
EQ2		[4:0]		00000 = -12dB 00001 = -11dB 11000 = +12dB
	10:6	EQ_B5_GAIN [4:0]	0_0000	EQ Band 5 Gain 00000 = -12dB 00001 = -11dB 11000 = +12dB

Table 20 EQ Band Gain Control

EQ GAIN SETTING	GAIN (DB)
00000	-12
00001	-11
00010	-10
00011	-9
00100	-8
00101	-7
00110	-6
00111	-5
01000	-4
01001	-3
01010	-2
01011	-1
01100	0
01101	+1
01110	+2
01111	+3
10000	+4
10001	+5
10010	+6
10011	+7
10100	+8
10101	+9
10110	+10
10111	+11
11000	+12
11001 to 11111	Reserved

Table 21 EQ Gain Control

RETUNE MOBILE MODE

ReTune Mobile mode provides a comprehensive facility for the user to define the cut-off/centre frequencies and filter bandwidth for each EQ band, in addition to the gain controls already described. This enables the EQ to be accurately customised for a specific transducer characteristic or desired sound profile.

The EQ enable and EQ gain controls are the same as defined for the default mode. The additional coefficients used in ReTune Mobile mode are held in registers R44 to R61. These coefficients are derived using tools provided in Cirrus Logic's WISCE™ evaluation board control software.

Please contact your local Cirrus Logic representative for more details.

EQ FILTER CHARACTERISTICS

The filter characteristics for each frequency band are shown in Figure 26 to Figure 30. These figures show the frequency response for all available gain settings, using default cut-off/centre frequencies and bandwidth.

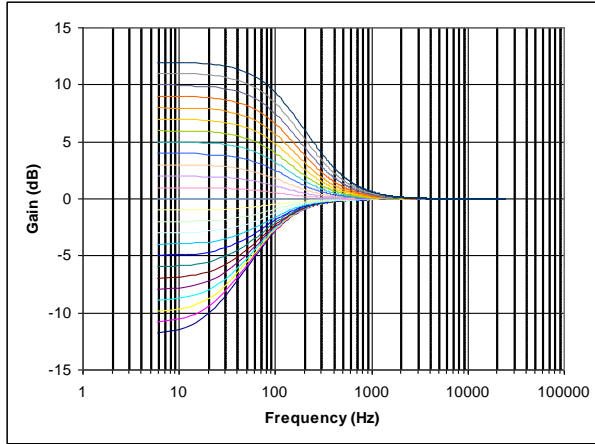
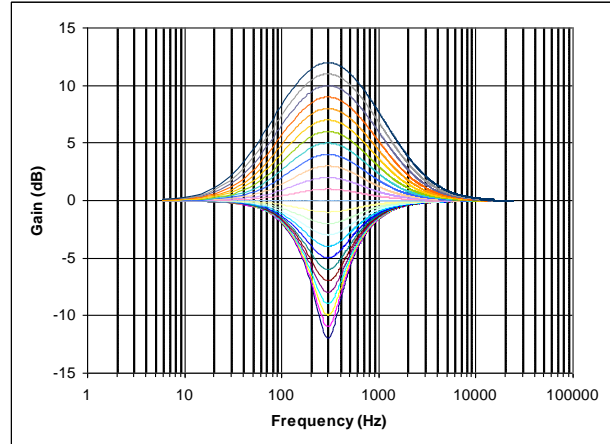
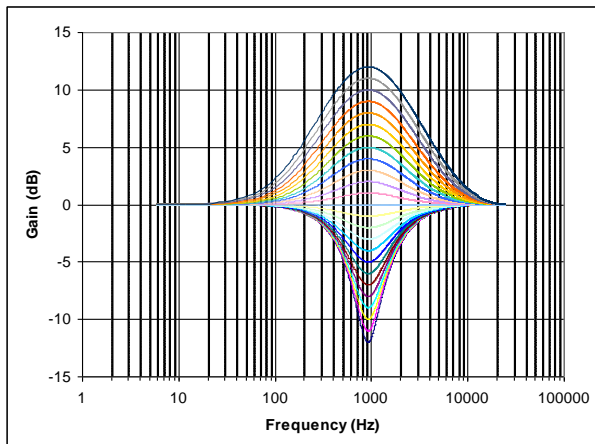
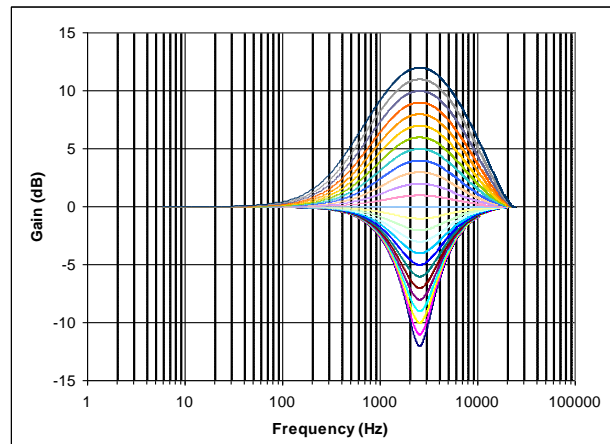
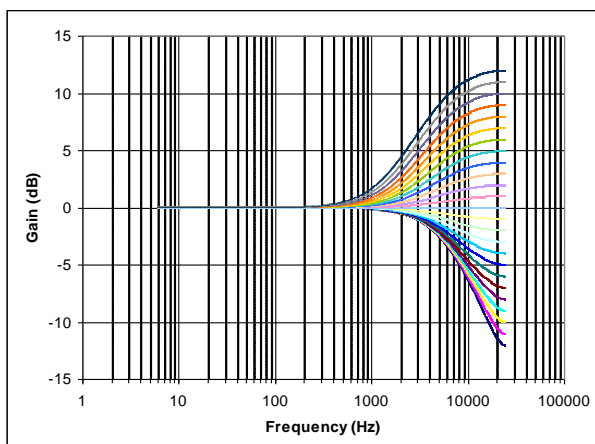
Figure 26 EQ Band 1 – Low Freq Shelf Filter Response

Figure 27 EQ Band 2 – Peak Filter Response

Figure 28 EQ Band 3 – Peak Filter Response

Figure 29 EQ Band 4 – Peak Filter Response

Figure 30 EQ Band 5 – High Freq Shelf Filter Response

DIGITAL TO ANALOGUE CONVERTER (DAC)

The WM9081 DAC receives digital input data from the DACDAT pin. The digital audio data is converted to oversampled bit streams in the on-chip, true 24-bit digital interpolation filters. The bitstream data enters a multi-bit, sigma-delta DAC, which converts it to a high quality analogue audio signal. The multi-bit DAC architecture reduces high frequency noise and sensitivity to clock jitter. It also uses a Dynamic Element Matching technique for high linearity and low distortion.

The analogue outputs from the DAC can then be mixed with other analogue inputs using the analogue mixer and can be output to the speaker amplifier or the line output.

The DAC is enabled by the DAC_ENA register bit.

REGISTER ADDRESS	BIT	LABEL	DEFAULT	DESCRIPTION
R11 (0Bh) Power Management	0	DAC_ENA	0	DAC Enable 0 = Disabled 1 = Enabled

Table 22 DAC Enable Control

DAC DIGITAL VOLUME CONTROL

The output level of each DAC can be controlled digitally over a range from -71.625dB to 0dB in 0.375dB steps. The level of attenuation for an eight-bit code X is given by:

$$0.375 \times (X-192) \text{ dB for } 1 \leq X \leq 192; \quad \text{MUTE for } X = 0 \quad 0\text{dB for } 192 \leq X \leq 255$$

REGISTER ADDRESS	BIT	LABEL	DEFAULT	DESCRIPTION
R30 (1Eh) DAC Digital 1	7:0	DAC_VOL [7:0]	1100_0000	DAC Volume and MUTE 0000 0000 = MUTE 0000 0001 = -71.625dB ... in steps of 0.375dB to 1100 0000 = 0dB 1100 0001 to 1111 1111 = reserved

Table 23 DAC Digital Volume Control

DAC SOFT MUTE AND SOFT UN-MUTE

The WM9081 has a soft mute function which, when enabled, gradually attenuates the volume of the DAC output. When soft mute is disabled, the gain will either gradually ramp back up to the digital gain setting, or return instantly to the digital gain setting, depending on the DAC_MUTEMODE register bit.

The DAC is soft-muted by default (DAC_MUTE = 1). To play back an audio signal, this function must first be disabled by setting DAC_MUTE to 0.

Soft Mute Mode would typically be enabled (DAC_MUTEMODE = 1) when using DAC_MUTE during playback of audio data so that when DAC_MUTE is subsequently disabled, the sudden volume increase will not create pop noise by jumping immediately to the previous volume level (e.g. resuming playback after pausing).

Soft Mute Mode would typically be disabled (DAC_MUTEMODE = 0) when un-muting at the start of audio playback, in order that the first part of the audio stream is not attenuated.

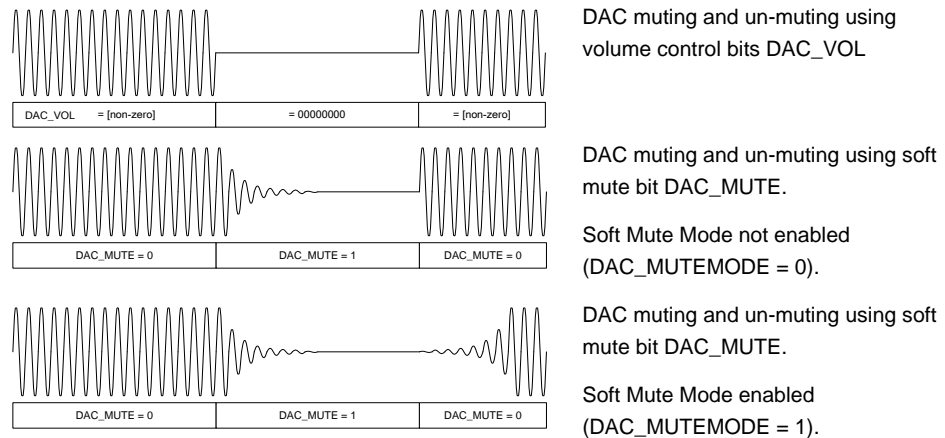
Figure 31 DAC Mute Control

The volume ramp rate during soft mute and un-mute is controlled by the DAC_MUTERATE bit. Ramp rates of $f_s/32$ and $f_s/2$ are selectable as shown in Table 24. The ramp rate determines the rate at which the volume will be increased or decreased. The actual ramp time depends on the extent of the difference between the muted and un-muted volume settings.

REGISTER ADDRESS	BIT	LABEL	DEFAULT	DESCRIPTION
R31 (1Fh) DAC Digital 2	10	DAC_MUTERATE	0	DAC Soft Mute Ramp Rate 0 = Fast ramp ($f_s/2$, maximum ramp time is 10.7ms at $f_s=48k$) 1 = Slow ramp ($f_s/32$, maximum ramp time is 171ms at $f_s=48k$) (Note: ramp rate scales with sample rate.)
	9	DAC_MUTEMODE	0	DAC Unmute Ramp select 0 = Disabling soft-mute (DAC_MUTE=0) will cause the DAC volume to change immediately to the DAC_VOL setting. 1 = Disabling soft-mute (DAC_MUTE=0) will cause the DAC volume to ramp up gradually to the DAC_VOL setting.
	3	DAC_MUTE	1	DAC Soft Mute Control 0 = DAC Un-mute 1 = DAC Mute

Table 24 DAC Soft-Mute Control

DAC DE-EMPHASIS

Digital de-emphasis can be applied to the DAC playback data (e.g. when the data comes from a CD with pre-emphasis used in the recording). De-emphasis filtering is available for sample rates of 48kHz, 44.1kHz and 32kHz. See "Digital Filter Characteristics" for details of de-emphasis filter characteristics.

REGISTER ADDRESS	BIT	LABEL	DEFAULT	DESCRIPTION
R31 (1Fh) DAC Digital 2	2:1	DEEMPH[1:0]	00	DAC De-Emphasis Control 00 = No de-emphasis 01 = 32kHz sample rate 10 = 44.1kHz sample rate 11 = 48kHz sample rate

Table 25 DAC De-Emphasis Control

SIGNAL PATH CONTROL

The inputs and outputs to the WM9081 are independently controlled as described in this section. The input signal paths comprise two line inputs and the digital audio interface input. The output signal paths comprise a line output and a selectable Class AB/D speaker driver.

INPUT SIGNAL PATH

There are three input signal paths to the analogue mixer. These are Line Input IN1, Line Input IN2 and the output from the DAC. These inputs can be mixed together as illustrated in Figure 32.

Line inputs IN1 and IN2 are enabled by the IN1_ENA and IN2_ENA registers. An optional -6dB gain can be selected in either path if required, using IN1_VOL and IN2_VOL.

The signal path from the DAC to the mixer is enabled by setting DAC_SEL, as described in Table 26. The DAC volume can be controlled in the digital domain as described in the “Digital to Analogue Converter (DAC)” section.

REGISTER ADDRESS	BIT	LABEL	DEFAULT	DESCRIPTION
R7 (07h) Analogue Mixer	4	DAC_SEL	0	DAC Path Enable 0 = Disabled 1 = Enabled
	3	IN2_VOL	0	IN2 Volume Control 0 = 0dB 1 = -6dB
	2	IN2_ENA	0	IN2 Path Enable 0 = Disabled 1 = Enabled
	1	IN1_VOL	0	IN1 Volume Control 0 = 0dB 1 = -6dB
	0	IN1_ENA	0	IN1 Path Enable 0 = Disabled 1 = Enabled

Table 26 Input Signal Path Control

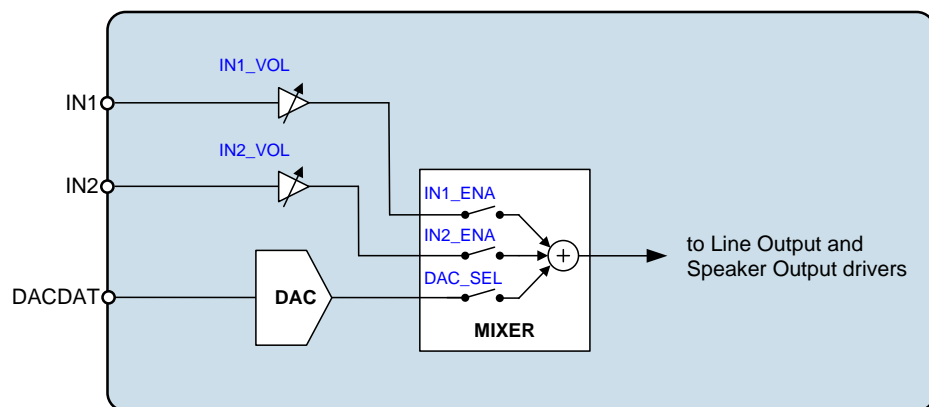

Figure 32 Input Signal Mixing

OUTPUT SIGNAL PATH

There are two output signal paths from the analogue mixer. These are the Line Output (on the LINEOUT pin) and the speaker output (on SPKOUTP and SPKOUTN).

The Line Output driver is enabled by setting LINEOUT_ENA. The Line Output can be muted or adjusted using the LINEOUT_MUTE and LINEOUT_VOL register fields, as described in Table 27.

The Speaker Output signal path is enabled in two parts, using SPKPGA_ENA and SPK_ENA. When powering up the speaker driver, the SPKPGA_ENA bit should be set before the SPK_ENA bit is set. The reverse sequence should be followed when powering down the speaker driver. The Speaker Output can be muted or adjusted using the SPKPGA_MUTE and SPKPGA_VOL register fields, as described in Table 27.

The speaker driver incorporates pop suppression circuits controlled by the SPK_INV_MUTE and OUT_SPK_CTRL registers. The default setting of these bits is logic 1. In normal operation, these bits must be set to logic 0. In Class D mode, these bits are controlled automatically by the WM9081 when SPK_ENA is written to. In Class AB mode, these bits must be set to logic 0 before SPK_ENA is enabled.

To prevent "zipper noise", a zero-cross function is provided on the Line Output and Speaker Output volume controls. When this feature is enabled, volume updates will not take place until a zero-crossing is detected. In the case of a long period without zero-crossings, a timeout function is provided. When the zero-cross function is enabled, the volume will update after the timeout period if no earlier zero-cross has occurred. The timeout clock is enabled using CLK_TO_ENA, the timeout period is set by CLK_TO_DIV. See "Clocking and Sample Rates" for more information on these fields.

REGISTER ADDRESS	BIT	LABEL	DEFAULT	DESCRIPTION
R2 (02h) Analogue Lineout	7	LINEOUT_MUTE	1	LINEOUT Mute 0 = Un-mute 1 = Mute
	6	LINEOUT_ZC	0	LINEOUT Zero Cross Detection 0 = Change gain immediately 1 = Change gain on zero cross only
	5:0	LINEOUT_VOL [5:0]	11_1001	LINEOUT Volume 00 0000 = -57dB 00 0001 = -56dB ... 11 1001 = 0dB ... 11 1111 = 6dB
R3 (03h) Analogue Speaker PGA	7	SPKPGA_MUTE	1	Speaker PGA Mute 0 = Un-mute 1 = Mute
	6	SPKPGA_ZC	0	Speaker PGA Zero Cross Detection 0 = Change gain immediately 1 = Change gain on zero cross only
	5:0	SPKPGA_VOL [5:0]	39h (0dB)	Speaker PGA Volume 00 0000 = -57dB 00 0001 = -56dB ... 11 1001 = 0dB ... 11 1111 = 6dB

REGISTER ADDRESS	BIT	LABEL	DEFAULT	DESCRIPTION
R10 (0Ah) Analogue Speaker 2	4	SPK_INV_MUTE	1	Controls a pop-suppression circuit for Speaker start-up. Controlled automatically by SPK_ENA in Class D mode. Must be set to 0 before enabling SPK_ENA in Class AB mode. 0 = Normal operation 1 = SPK_INV_MUTE enabled
	3	OUT_SPK_CTRL	1	Controls a pop-suppression circuit for Speaker start-up. Controlled automatically by SPK_ENA in Class D mode. Must be set to 0 before enabling SPK_ENA in Class AB mode. 0 = Normal operation 1 = OUT_SPK_CTRL enabled
R11 (0Bh) Power Management	4	LINEOUT_ENA	0	LINEOUT Enable 0 = Disabled 1 = Enabled
	2	SPKPGA_ENA	0	Speaker PGA Enable 0 = Disabled 1 = Enabled
	1	SPK_ENA	0	Speaker Output Enable 0 = Disabled 1 = Enabled

Table 27 Output Signal Path Control

ANALOGUE OUTPUTS

The WM9081 provides a mono Line Output and a mono Speaker Output. These are described individually in the subsections below.

SPEAKER OUTPUT CONFIGURATION

The speaker output is a Class D BTL configuration by default. The speaker driver can be configured to operate in Class AB mode by setting SPK_MODE = 1.

The analogue mixer circuit and the speaker PGA are powered by AVDD, whilst the speaker driver is powered by SPKVDD. Six levels of AC and DC signal boost are provided in order to deliver maximum output power for many commonly-used SPKVDD/AVDD combinations. These boost options are available in both Class AB and Class D modes. The boost levels from 0dB to +5.1dB are selected using register bits SPK_DCGAIN and SPK_ACGAIN. Note that the BTL output configuration provides an additional 6dB gain. To prevent pop noise, these registers should not be modified while the speaker outputs are enabled. Figure 33 illustrates the available mixing and speaker output configuration. Table 28 shows the gain/boost options.

Ultra-low leakage and high PSRR allow the speaker supply SPKVDD to be directly connected to a lithium battery. Note that an appropriate SPKVDD supply voltage must be provided to prevent waveform clipping when speaker boost is used.

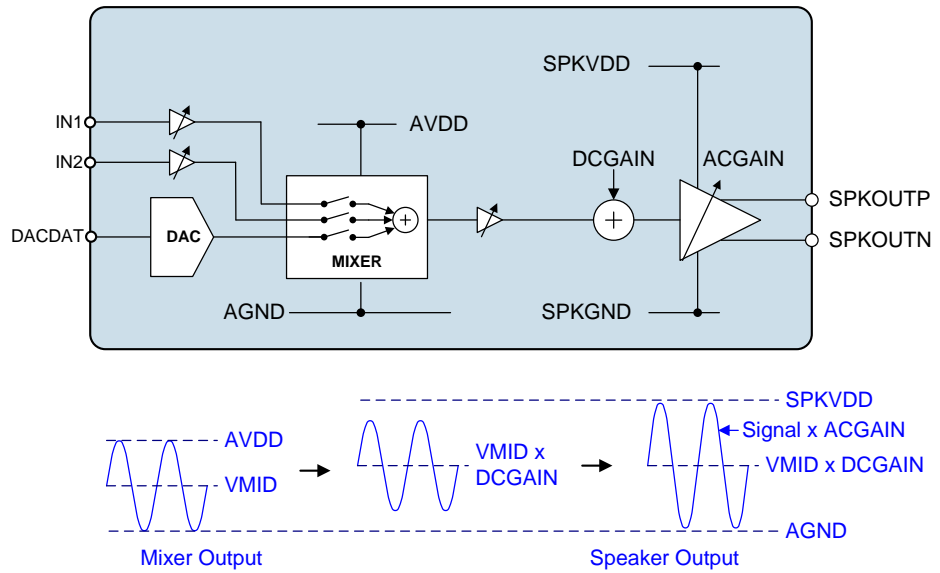
Figure 33 Speaker Gain Control

DC GAIN [5:3] AND AC GAIN [2:0] FROM OUTPUT MIXER OUTPUT TO SPEAKER AMP INPUT		
DC GAIN = AC GAIN	Gain [dB]	Gain
000	0	1.00x
001	2.1	1.27x
010	2.9	1.40x
011	3.6	1.52x
100	4.5	1.67x
101	5.1	1.8x
110 – 111	Reserved	Reserved

Table 28 DC gain and AC gain

The speaker mode select and the speaker gain controls are described in Table 29. Note that the BTL output configuration provides an additional 6dB gain.

REGISTER ADDRESS	BIT	LABEL	DEFAULT	DESCRIPTION
R9 (09h) Analogue Speaker 1	5:3	SPK_DCGAIN [2:0]	011 (+3.6dB)	Speaker Output DC Gain 000 = x1 boost (0dB) 001 = x1.27 boost (2.1dB) 010 = x1.4 boost (2.9dB) 011 = x1.52 boost (3.6dB) 100 = x1.67 boost (4.5dB) 101 = x1.8 boost (5.1dB) 110-111 = Reserved
	2:0	SPK_ACGAIN [2:0]	011 (+3.6dB)	Speaker Output AC Gain 000 = x1 boost (0dB) 001 = x1.27 boost (2.1dB) 010 = x1.4 boost (2.9dB) 011 = x1.52 boost (3.6dB) 100 = x1.67 boost (4.5dB) 101 = x1.8 boost (5.1dB) 110-111 = Reserved
R10 (0Ah) Analogue Speaker 2	6	SPK_MODE	0	Speaker Mode Select 0 = Class D mode 1 = Class AB mode

Table 29 Speaker Output Control

LINE OUTPUT CONFIGURATION

The line output, LINEOUT, provides a single-ended analogue output for connection to other circuits. Note that the line output is referenced to VMID, and external DC-blocking capacitors are required when connecting this output to other devices.

The line output is enabled and controlled using the registers described in the “Output Signal Path” section.

POP SUPPRESSION CONTROL

The WM9081 incorporates a number of features, including Cirrus Logic's SilentSwitch™ technology, designed to suppress pops normally associated with Start-Up, Shut-Down or signal path control. To achieve maximum benefit from these features, careful attention is required to the sequence and timing of these controls. Note that, under the recommended usage conditions of the WM9081, these features will be configured automatically by running the default control sequences as described in the "Control Write Sequencer" section. In these cases, the user does not need to set these register fields directly. Additional bias controls, also pre-programmed into Control Write Sequencer, are described in the "Reference Voltages and Master Bias" section.

DISABLED LINE OUTPUT CONTROL

The line output is biased to VMID in normal operation. In order to avoid audible pops caused by a disabled signal path dropping to AGND, the WM9081 can maintain LINEOUT at VMID when this output is disabled. This is achieved by connecting a buffered VMID reference to LINEOUT. The buffered VMID reference is enabled by setting VMID_BUF_ENA. When the line output is disabled, the reference is connected to LINEOUT by setting LINEOUT_CLAMP. The output resistance can be either 500Ω or 20kΩ, depending on the LINEOUT_VROI register bit.

REGISTER ADDRESS	BIT	LABEL	DEFAULT	DESCRIPTION
R4 (04h) VMID Control	5	VMID_BUF_ENA	0	Enables VMID reference for lineout and inputs clamps 0 = Disabled 1 = Enabled
R8 (08h) AntiPop Control	1	LINEOUT_VROI	0	Buffered VMID to LINEOUT Resistance. This applies when LINEOUT_ENA = 0 and LINEOUT_CLAMP = 1. 0 = 20kΩ from buffered VMID to output 1 = 500Ω from buffered VMID to output
	0	LINEOUT_CLAMP	0	Clamp LINEOUT to buffered VMID. VMID_BUF_ENA must be set. This bit is only effective when LINEOUT_ENA = 0. The resistance is set by LINEOUT_VROI. 0 = Disabled 1 = Enabled (LINEOUT clamped to VMID)

Table 30 Disabled Line Output Control

LINE OUTPUT DISCHARGE CONTROL

The line output can be actively discharged to AGND through an internal resistor if desired. This is desirable at start-up in order to achieve a known output stage condition prior to enabling the soft-start VMID reference voltage. This is also desirable in shut-down to prevent the external connections from being affected by the internal circuits. The LINEOUT pin is discharged to AGND by setting LINEOUT_DISCH.

REGISTER ADDRESS	BIT	LABEL	DEFAULT	DESCRIPTION
R8 (08h) AntiPop Control	2	LINEOUT_DISCH	0	Discharges LINEOUT via approx 5kohm resistor 0 = Not active 1 = Actively discharging LINEOUT

Table 31 Line Output Discharge Control

DIGITAL AUDIO INTERFACE

The digital audio interface is used for inputting DAC data to the WM9081. The digital audio interface uses three pins:

- DACDAT: DAC data input
- LRCLK: Left/Right data alignment clock
- BCLK: Bit clock, for synchronisation

In Software Control mode, many different audio data formats can be selected. In Hardware Control mode, only a limited range of formats is supported.

SOFTWARE CONTROL MODE

In Software Control mode, the clock signals BCLK and LRCLK can be configured individually as inputs or outputs, enabling master or slave modes of operation.

The WM9081 receives either the Left channel or the Right channel data from a stereo digital audio source. Four different audio data formats are supported:

- Left justified
- Right justified
- I²S
- DSP mode

PCM operation is supported using the DSP mode. All four of these modes are MSB first. They are described in Audio Data Formats, below. Refer to the “Signal Timing Requirements” section for timing information.

The word length of the audio data can be selected; the WM9081 supports 8, 16, 20, 24 and 32 bit word lengths. A-law and μ -law companding is supported in 8-bit mode.

Time Division Multiplexing (TDM) is available in all four data format modes. The WM9081 can be programmed to receive data in any of up to four stereo time slots.

HARDWARE CONTROL MODE

In Hardware Control mode, the WM9081 operates in slave mode, where the clock signals BCLK and LRCLK are both inputs. The only supported sample rate is 48kHz; the controlling device must ensure that the clocks and the data input are consistent with this.

The data format is 16-bit I²S mode, as described in “Audio Data Formats (Normal Mode)” below. The Left/Right channel selection is made using the SCIM/CHANNEL pin, as described in “Control Interface (Hardware Mode)”.

Companding and TDM modes are not supported in Hardware Control mode.

MASTER AND SLAVE MODE OPERATION

The WM9081 digital audio interface can operate as a master or slave as shown in Figure 34 and Figure 35.

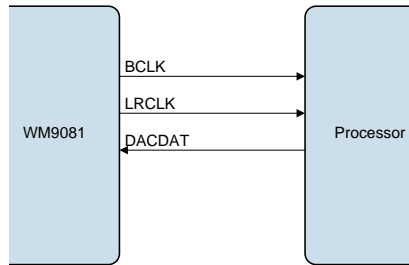

Figure 34 Master Mode

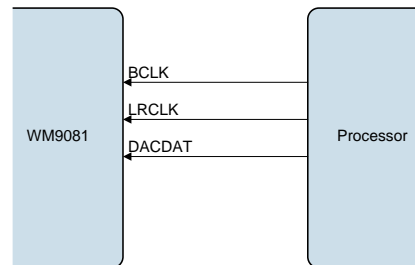

Figure 35 Slave Mode

The Audio Interface output control is illustrated above. BCLK and LRCLK are configured as inputs or outputs using the BCLK_DIR and LRCLK_DIR register fields - see "Digital Audio Interface Control".

Note that BCLK and LRCLK can be configured independently as inputs or outputs, allowing mixed Master/Slave operation.

OPERATION WITH TDM

Time division multiplexing (TDM) allows multiple devices to transfer data simultaneously on the same bus. The WM9081 DAC supports TDM in master and slave modes for all data formats and word lengths. TDM is enabled and configured using register bits defined in the "Digital Audio Interface Control" section.

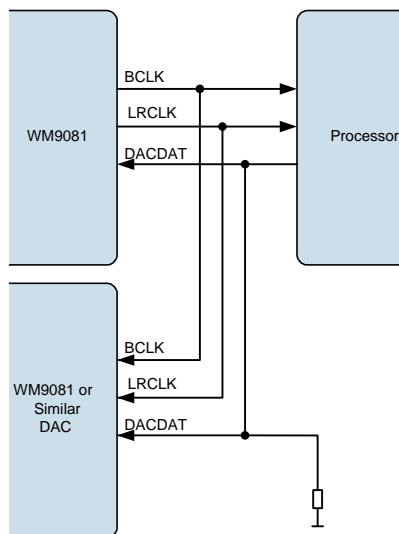

Figure 36 TDM with WM9081 as Master

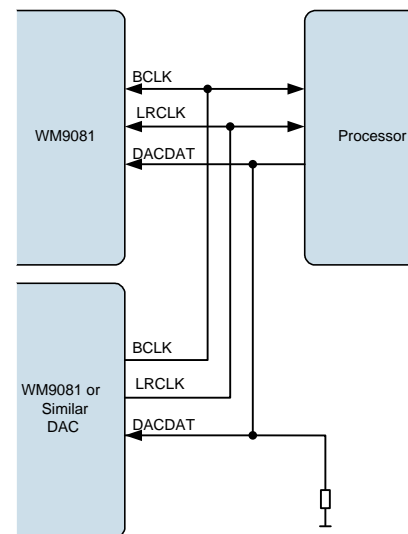

Figure 37 TDM with Other DAC as Master

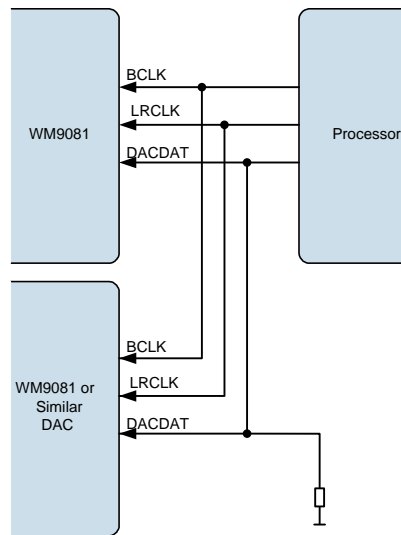

Figure 38 TDM with Processor as Master

Note: The WM9081 is a 24-bit device. If the user operates the WM9081 in 32-bit mode then the 8 LSBs will be ignored by the DAC. To ensure the DACDAT line is never left floating (eg. when using a mixture of 24-bit and 32-bit devices), it is recommended to add a pull-down resistor to the DACDAT line.

BCLK FREQUENCY

The BCLK frequency is controlled relative to CLK_SYS by the BCLK_DIV divider. Internal clock divide and phase control mechanisms ensure that the BCLK and LRCLK edges will occur in a predictable and repeatable position relative to each other and relative to the data for a given combination of DAC sample rate and BCLK_DIV settings.

BCLK_DIV is defined in the “Digital Audio Interface Control” section. See also “Clocking and Sample Rates” section for more information.

AUDIO DATA FORMATS (NORMAL MODE)

In Right Justified mode, the LSB is available on the last rising edge of BCLK before a LRCLK transition. All other bits are transmitted before (MSB first). Depending on word length, BCLK frequency and sample rate, there may be unused BCLK cycles after each LRCLK transition.

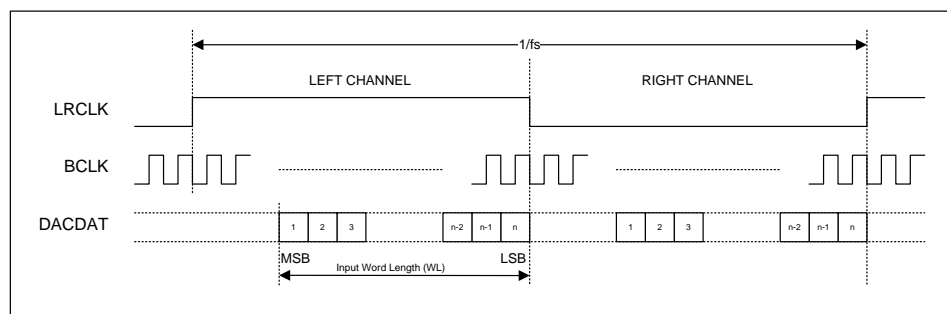

Figure 39 Right Justified Audio Interface (assuming n-bit word length)

In Left Justified mode, the MSB is available on the first rising edge of BCLK following a LRCLK transition. The other bits up to the LSB are then transmitted in order. Depending on word length, BCLK frequency and sample rate, there may be unused BCLK cycles before each LRCLK transition.

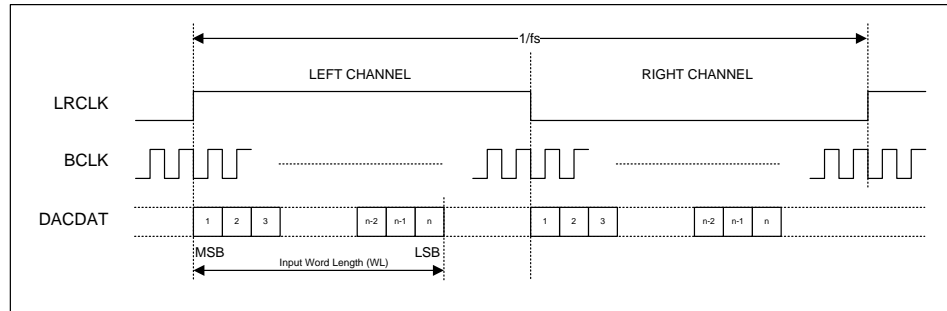

Figure 40 Left Justified Audio Interface (assuming n-bit word length)

In I²S mode, the MSB is available on the second rising edge of BCLK following a LRCLK transition. The other bits up to the LSB are then transmitted in order. Depending on word length, BCLK frequency and sample rate, there may be unused BCLK cycles between the LSB of one sample and the MSB of the next.

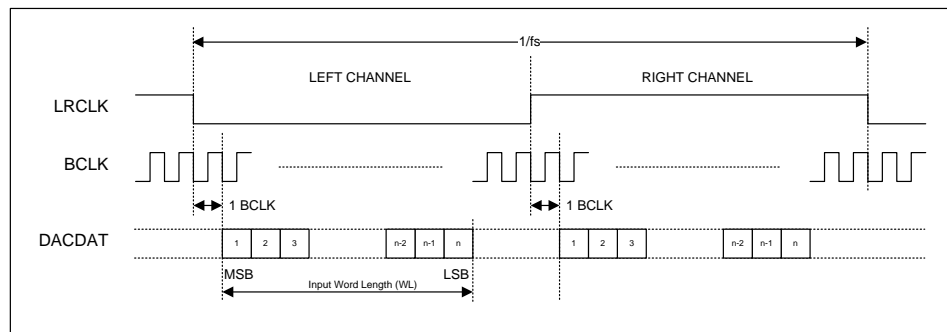

Figure 41 I2S Justified Audio Interface (assuming n-bit word length)

In DSP mode, the left channel MSB is available on either the 1st (mode B) or 2nd (mode A) rising edge of BCLK (selectable by AIF_LRCLK_INV) following a rising edge of LRCLK. Right channel data immediately follows left channel data. Depending on word length, BCLK frequency and sample rate, there may be unused BCLK cycles between the LSB of the right channel data and the next sample.

In device master mode, the LRCLK output will resemble the frame pulse shown in Figure 42 and Figure 43. In device slave mode, Figure 44 and Figure 45, it is possible to use any length of frame pulse less than 1/fs, providing the falling edge of the frame pulse occurs greater than one BCLK period before the rising edge of the next frame pulse.

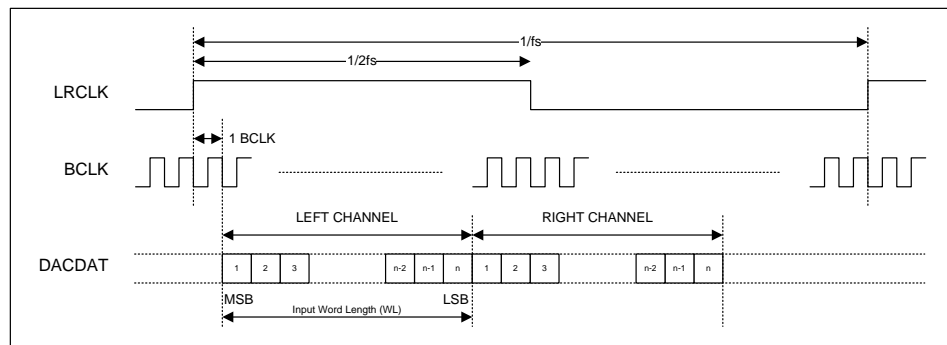

Figure 42 DSP Mode Audio Interface (mode A, AIF_LRCLK_INV=0, Master)

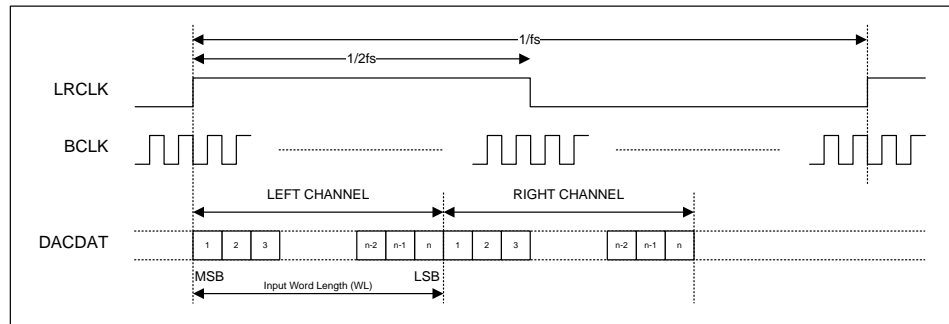

Figure 43 DSP Mode Audio Interface (mode B, AIF_LRCLK_INV=1, Master)

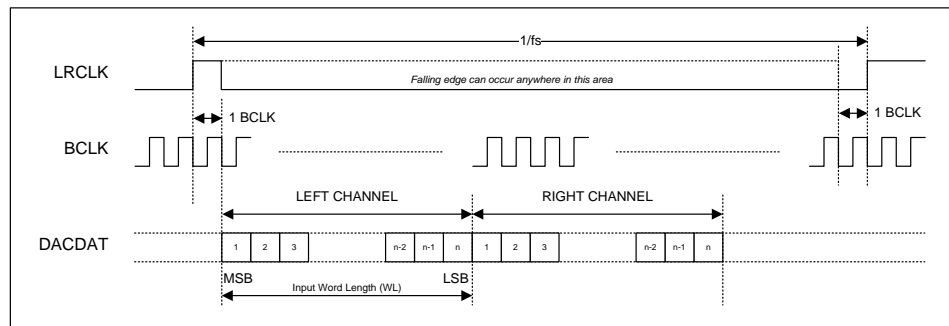

Figure 44 DSP Mode Audio Interface (mode A, AIF_LRCLK_INV=0, Slave)

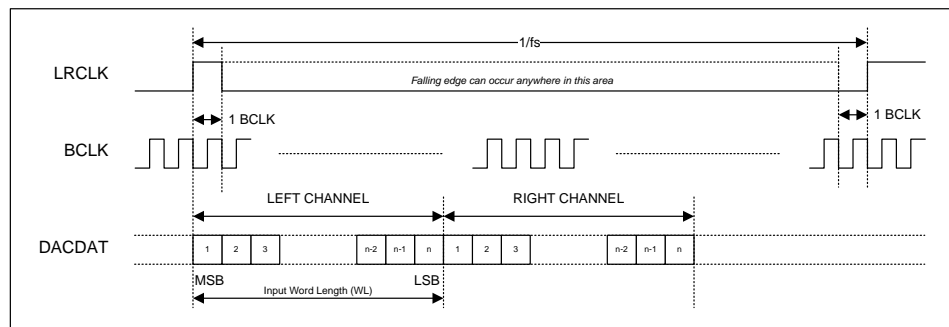

Figure 45 DSP Mode Audio Interface (mode B, AIF_LRCLK_INV=1, Slave)

PCM operation is supported in DSP interface mode. Mono PCM data received by the WM9081 will be treated as Left Channel data. The left channel must be selected by the WM9081 in order for this data to be routed to the output drivers.

AUDIO DATA FORMATS (TDM MODE)

TDM is supported in master and slave mode and is enabled using the AIFDAC_TDM_MODE register field. All audio interface data formats support time division multiplexing (TDM). The AIFDAC_TDM_MODE identifies the number of stereo time slots in the received data. Up to four stereo time slots can be selected. The AIFDAC_TDM_SLOT field identifies which of the available time slots contains the data that is to be received by the WM9081.

When TDM is enabled, BCLK frequency must be high enough to allow data from all time slots to be transferred. The relative timing of the audio interface timeslots depends upon the selected data format as shown in Figure 46 to Figure 50. A maximum of four stereo time slots can be supported in each data format. The following figures illustrate only a subset of the available options.

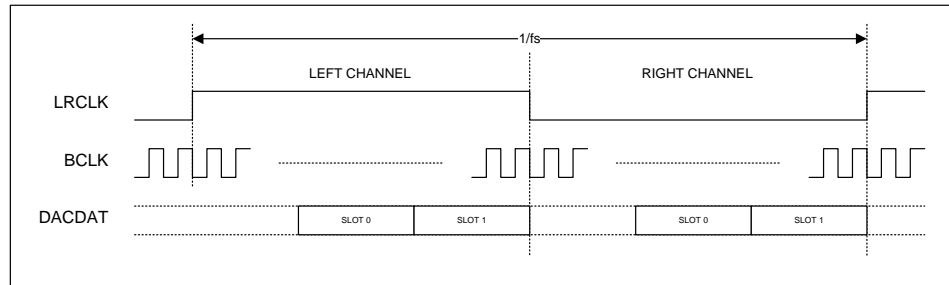

Figure 46 TDM in Right-Justified Mode - 2 Stereo Time Slots

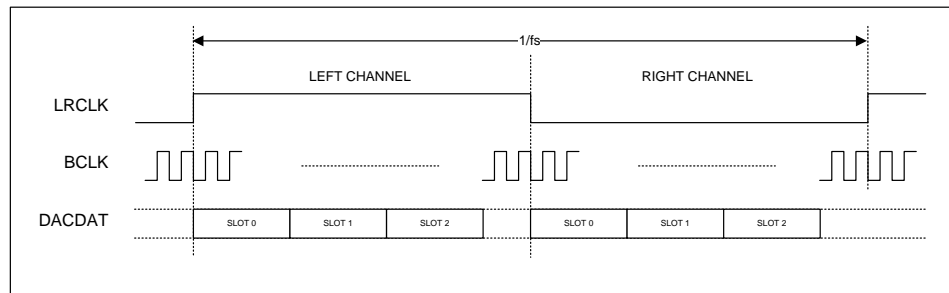

Figure 47 TDM in Left-Justified Mode - 3 Stereo Time Slots

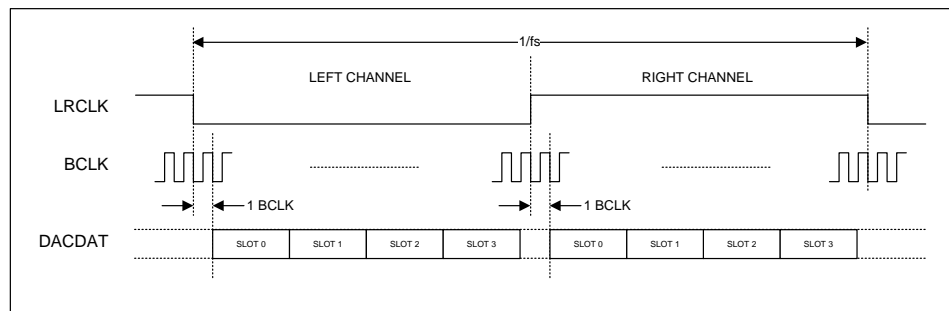

Figure 48 TDM in I²S Mode - 4 Stereo Time Slots

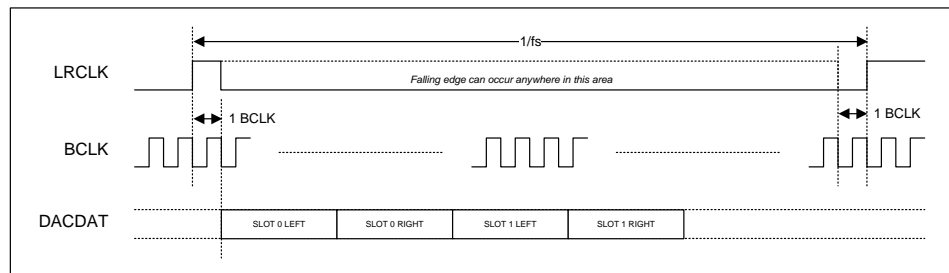
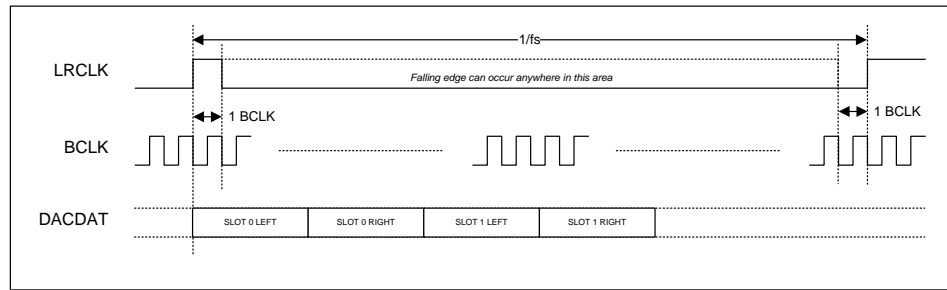

Figure 49 TDM in DSP Mode A - 2 Stereo Time Slots

Figure 50 TDM in DSP Mode B - 2 Stereo Time Slots

DIGITAL AUDIO INTERFACE CONTROL

The register bits controlling audio data format, word length, left/right channel data source and TDM are summarised in Table 32.

REGISTER ADDRESS	BIT	LABEL	DEFAULT	DESCRIPTION
R22 (16h) Audio Interface 1	6	AIFDAC_CHAN	0	DAC Data Source Select 0 = DAC selects left channel data 1 = DAC selects right channel data
	5:4	AIFDAC_TDM_SLOT	00	DAC TDM Slot Select 00 = Select slot 0 (Left/Right) 01 = Select slot 1 (Left/Right) 10 = Select slot 2 (Left/Right) 11 = Select slot 3 (Left/Right)
	3:2	AIFDAC_TDM_MODE	00	DAC TDM Mode Select 00 = 1 stereo slot (TDM off) 01 = 2 stereo slots 10 = 3 stereo slots 11 = 4 stereo slots
R23 (17h) Audio Interface 2	8	DAC_DAT_INV	0	DACDAT Invert 0 = DACDAT not inverted 1 = DACDAT inverted
	7	AIF_BCLK_INV	0	BCLK Invert 0 = BCLK not inverted 1 = BCLK inverted
	4	AIF_LRCLK_INV	0	Right, left and I ² S modes – LRCLK polarity: 0 = normal LRCLK polarity 1 = invert LRCLK polarity DSP Mode – mode A/B select : 0 = MSB is available on 2nd BCLK rising edge after LRC rising edge (mode A) 1 = MSB is available on 1st BCLK rising edge after LRC rising edge (mode B)
	3:2	AIF_WL [1:0]	00	Digital Audio Interface Word Length 00 = 16 bits 01 = 20 bits 10 = 24 bits 11 = 32 bits Note - see “Companding” for the selection of 8-bit mode.

REGISTER ADDRESS	BIT	LABEL	DEFAULT	DESCRIPTION
	1:0	AIF_FMT [1:0]	10	Digital Audio Interface Format 00 = Right justified 01 = Left justified 10 = I ² S Format 11 = DSP Mode

Table 32 Digital Audio Interface Data Control

AUDIO INTERFACE OUTPUT TRI-STATE

Register bit AIF_TRIS can be used to tri-state the audio interface pins LRCLK and BCLK as described in Table 33. This function tri-states the audio interface pins regardless of the state of other registers which control these pin configurations.

REGISTER ADDRESS	BIT	LABEL	DEFAULT	DESCRIPTION
R23 (17h) Audio Interface 2	9	AIF_TRIS	0	Audio Interface Tristate 0 = Audio interface pins operate normally 1 = Tristate all audio interface pins

Table 33 Digital Audio Interface Tri-State Control

BCLK AND LRCLK CONTROL

The audio interface can be programmed to operate in master mode or slave mode by configuring BCLK and LRCLK as outputs or inputs respectively. The direction of these signals is configured using the BCLK_DIR and LRCLK_DIR register fields.

In master mode, the BCLK and LRCLK signals are generated by the WM9081 when the DAC is enabled. In slave mode, the BCLK and LRCLK clock outputs are disabled by default to allow another digital audio interface to drive these pins.

Note that BCLK and LRCLK can be configured independently as inputs or outputs, allowing mixed Master/Slave operation.

In master mode, BCLK is derived from CLK_SYS via a programmable division set by BCLK_DIV.

In master mode, LRCLK is derived from BCLK via a programmable division set by LRCLK_RATE. The BCLK input to this divider may be internal or external, allowing mixed master and slave modes.

The BCLK and LRCLK control fields are defined in Table 34.

REGISTER ADDRESS	BIT	LABEL	DEFAULT	DESCRIPTION
R23 (17h) Audio Interface 2	6	BCLK_DIR	0	BCLK Direction (Forces BCLK clock to be output in slave mode) 0 = BCLK normal operation 1 = BCLK clock output enabled
	5	LRCLK_DIR	0	LRCLK Direction (Forces LRCLK clock to be output in slave mode) 0 = LRCLK normal operation 1 = LRCLK clock output enabled

REGISTER ADDRESS	BIT	LABEL	DEFAULT	DESCRIPTION
R24 (18h) Audio Interface 3	4:0	BCLK_DIV [4:0]	0_1000	BCLK Rate 00000 = CLK_SYS 00001 = CLK_SYS / 1.5 00010 = CLK_SYS / 2 00011 = CLK_SYS / 3 00100 = CLK_SYS / 4 00101 = CLK_SYS / 5 00110 = CLK_SYS / 5.5 00111 = CLK_SYS / 6 01000 = CLK_SYS / 8 01001 = CLK_SYS / 10 01010 = CLK_SYS / 11 01011 = CLK_SYS / 12 01100 = CLK_SYS / 16 01101 = CLK_SYS / 20 01110 = CLK_SYS / 22 01111 = CLK_SYS / 24 10000 = CLK_SYS / 25 10001 = CLK_SYS / 30 10010 = CLK_SYS / 32 10011 = CLK_SYS / 44 10100 = CLK_SYS / 48
R25 (19h) Audio Interface 4	10:0	LRCLK_RATE [10:0]	000_0010_0010	LRCLK Rate LRCLK clock output = BCLK / LRCLK_RATE Integer (LSB = 1) Valid from 8..2047

Table 34 Digital Audio Interface Clock Control

COMPANDING

The WM9081 supports A-law and μ -law companding as shown in Table 35.

REGISTER ADDRESS	BIT	LABEL	DEFAULT	DESCRIPTION
R22 (16h) Audio Interface 1	1	DAC_COMP	0	DAC Companding Enable 0 = Disabled 1 = Enabled
	0	DAC_COMPMODE	0	DAC Companding Type 0 = μ -law 1 = A-law

Table 35 Companding Control

Companding involves using a piecewise linear approximation of the following equations (as set out by ITU-T G.711 standard) for data compression:

μ -law (where $\mu=255$ for the U.S. and Japan):

$$F(x) = \ln(1 + \mu|x|) / \ln(1 + \mu) \quad -1 \leq x \leq 1$$

A-law (where $A=87.6$ for Europe):

$$F(x) = A|x| / (1 + \ln A) \quad \text{for } x \leq 1/A$$

$$F(x) = (1 + \ln A|x|) / (1 + \ln A) \quad \text{for } 1/A \leq x \leq 1$$

The companded data is also inverted as recommended by the G.711 standard (all 8 bits are inverted for μ -law, all even data bits are inverted for A-law). The data will be transmitted as the first 8 MSBs of data.

Companding converts 13 bits (μ -law) or 12 bits (A-law) to 8 bits using non-linear quantization. This provides greater precision for low amplitude signals than for high amplitude signals, resulting in a greater usable dynamic range than 8 bit linear quantization. The companded signal is an 8-bit word comprising sign (1 bit), exponent (3 bits) and mantissa (4 bits).

8-bit mode is selected whenever $DAC_COMP=1$. The use of 8-bit data allows samples to be passed using as few as 8 BCLK cycles per LRCLK frame. When using DSP mode B, 8-bit data words may be transferred consecutively every 8 BCLK cycles.

8-bit mode (without Companding) may be enabled by setting $DAC_COMPMODE=1$ when $DAC_COMP=0$.

BIT7	BIT[6:4]	BIT[3:-0]
SIGN	EXPONENT	MANTISSA

Table 36 8-bit Companded Word Composition

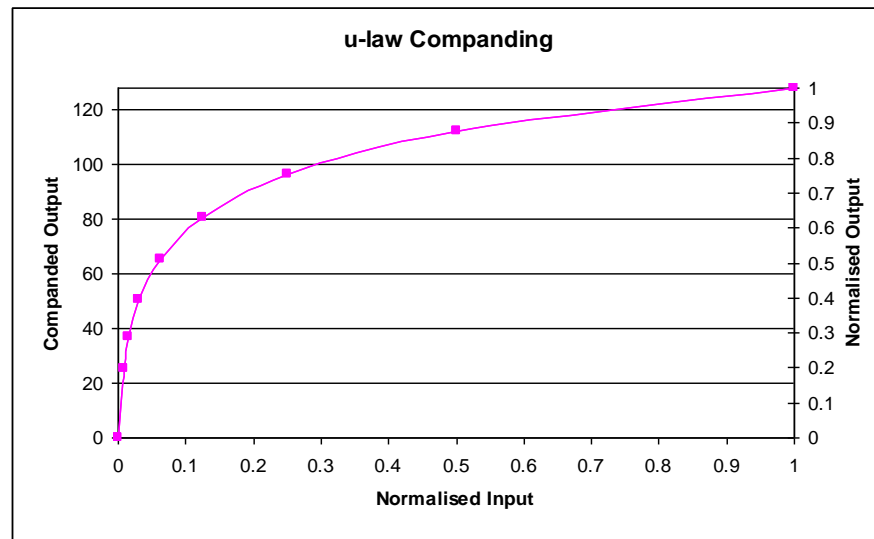

Figure 51 μ -Law Companding

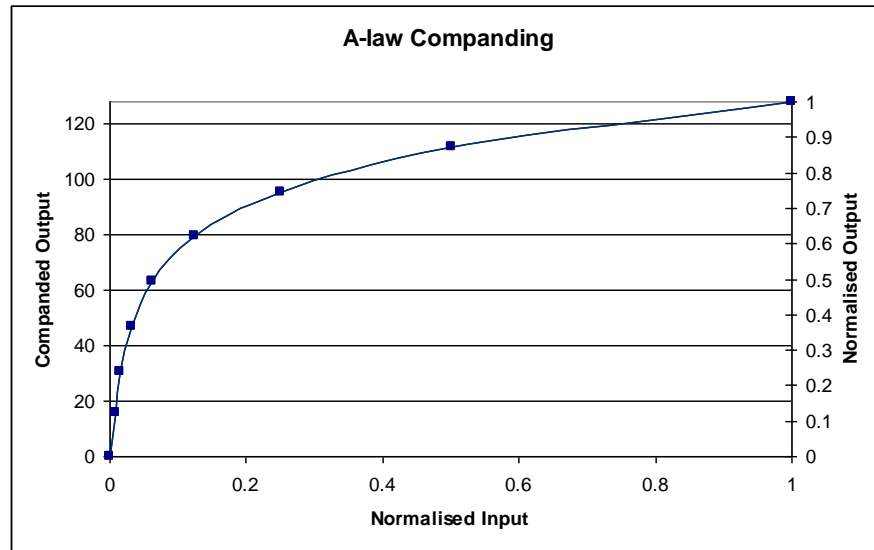

Figure 52 A-Law Comping

CLOCKING AND SAMPLE RATES

The internal clocks for the WM9081 are all derived from a common internal clock source, CLK_SYS. This clock is the reference for the DSP / DAC core functions, digital audio interface, Class D switching amplifier, write sequencer and other internal functions.

CLK_SYS can either be derived directly from MCLK, or may be generated from a Frequency Locked Loop (FLL) using MCLK, BCLK or LRCLK as a reference. All commonly-used audio sample rates can be derived directly from typical MCLK frequencies; the FLL provides additional flexibility for a wider range of MCLK frequencies. To avoid audible glitches, all clock configurations must be set up before enabling playback. The FLL can be used to generate a free-running clock in the absence of an external reference source; see "Frequency Locked Loop (FLL)" for further details.

The WM9081 supports a wide range of standard audio sample rates from 8kHz to 96kHz. The core clocking requirements of the WM9081 are automatically configured according to the selected Sample Rate and the applicable CLK_SYS / fs ratio. These parameters are contained in the SAMPLE_RATE and CLK_SYS_RATE register fields respectively.

A slow clock, TOCLK, is used to set the timeout period for volume updates when zero-cross detect is used. This clock is enabled by CLK_TO_ENA and controlled by CLK_TO_DIV.

A clock output, OPCLK, can be derived from CLK_SYS and output on the MCLK pin to provide clocking to other devices. This clock is enabled by CLK_OP_ENA and controlled by CLK_OP_DIV. This feature is only available when MCLK is not selected as an input to the WM9081.

In master mode, BCLK is derived from CLK_SYS via a programmable divider set by BCLK_DIV. In master mode, the LRCLK is derived from BCLK via a programmable divider LRCLK_RATE. The LRCLK can be derived from an internal or external BCLK source, allowing mixed master/slave operation. See "Digital Audio Interface Control" for details of the BCLK and LRCLK configuration.

The control registers associated with Clocking and Sample Rates are shown in Table 37 to Table 39.

The overall clocking scheme for the WM9081 is illustrated in Figure 53.

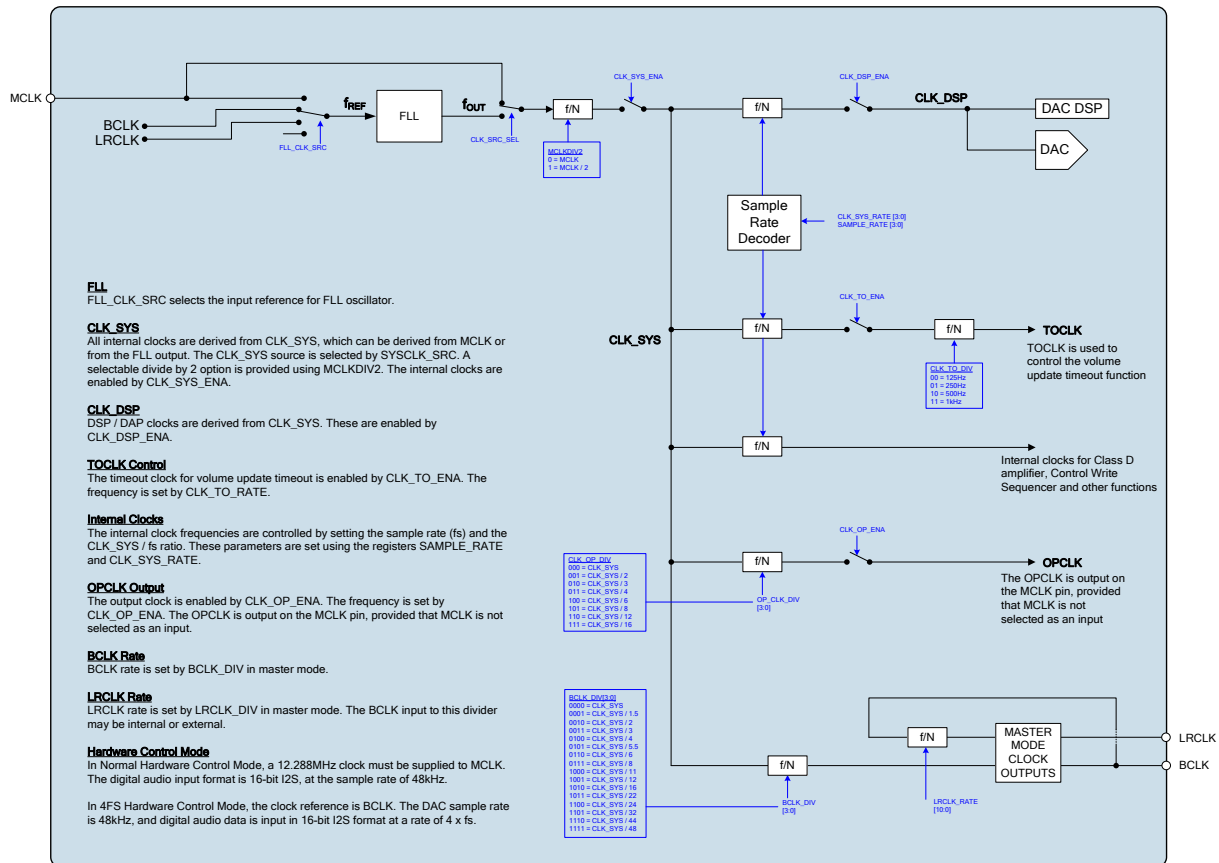

Figure 53 WM9081 Clocking Overview

CLK_SYS CONTROL

The CLK_SRC_SEL bit is used to select the source for CLK_SYS. The source can be either MCLK or the FLL output. The selected source may also be adjusted by the MCLKDIV2 to generate CLK_SYS. These register fields are described in Table 37. See “Frequency Locked Loop (FLL)” for more details of the Frequency Locked Loop clock generator.

The CLK_SYS signal is enabled by register bit CLK_SYS_ENA. This bit should be set to 0 when reconfiguring clock sources or when no clock source is present. It is not recommended to change MCLK_SRC or CLK_SRC_SEL while the CLK_SYS_ENA bit is set.

The core clocking requirements are configured by setting the SAMPLE_RATE and CLK_SYS_RATE fields as described in Table 37. The WM9081 supports DAC sample rates (fs) from 8kHz up to 96kHz. The CLK_SYS_RATE field must be set according to the ratio of CLK_SYS to fs.

The DSP / DAC clock function is enabled by register bit CLK_DSP_ENA.

REGISTER ADDRESS	BIT	LABEL	DEFAULT	DESCRIPTION
R12 (0Ch) Clock Control1	7	MCLKDIV2	0	MCLK Divider 0 = MCLK 1 = MCLK / 2
R13 (0Dh) Clock Control2	7:4	CLK_SYS_RATE [3:0]	0011	Selects the CLK_SYS / fs ratio 0000 = 64 0001 = 128 0010 = 192 0011 = 256 0100 = 384 0101 = 512 0110 = 768 0111 = 1024 1000 = 1408 1001 = 1536
	3:0	SAMPLE_RATE [3:0]	1000	Selects the Sample Rate (fs) 0000 = 8kHz 0001 = 11.025kHz 0010 = 12kHz 0011 = 16kHz 0100 = 22.05kHz 0101 = 24kHz 0110 = 32kHz 0111 = 44.1kHz 1000 = 48kHz 1001 = 88.2kHz 1010 = 96kHz 1011 to 1111 = Reserved
R14 (0Eh) Clock Control3	13	CLK_SRC_SEL	0	CLK_SYS Source Select 0 = MCLK 1 = FLL output
	1	CLK_DSP_ENA	0	CLK_DSP enable 0 = Disabled 1 = Enabled
	0	CLK_SYS_ENA	0	CLK_SYS enable 0 = Disabled 1 = Enabled

Table 37 CLK_SYS Control

TOCLK CONTROL

A timeout clock (TOCLK) is derived from CLK_SYS as an input to the zero-cross volume update function. This clock is enabled by register bit CLK_TO_ENA, and its frequency is controlled by CLK_TO_RATE, as described in Table 38.

REGISTER ADDRESS	BIT	LABEL	DEFAULT	DESCRIPTION
R12 (0Ch) Clock Control1	9:8	CLK_TO_DIV [1:0]	00	TOCLK (timeout/ slow clock) frequency select 00 = 125Hz 01 = 250Hz 10 = 500Hz 11 = 1kHz
R14 (0Eh) Clock Control3	2	CLK_TO_ENA	0	TOCLK (timeout/ slow clock) Enable 0 = Disabled 1 = Enabled

Table 38 TOCLK Control

OPCLK CONTROL

A clock output (OPCLK) derived from CLK_SYS may be output on the MCLK pin. This clock is enabled by register bit CLK_OP_ENA, and its frequency is controlled by CLK_OP_DIV.

This output is only supported when MCLK is not selected as an input to the WM9081.

REGISTER ADDRESS	BIT	LABEL	DEFAULT	DESCRIPTION
R12 (0Ch) Clock Control1	12:10	CLK_OP_DIV [2:0]	000	OPCLK Clock Divider 000 = CLK_SYS 001 = CLK_SYS / 2 010 = CLK_SYS / 3 011 = CLK_SYS / 4 100 = CLK_SYS / 6 101 = CLK_SYS / 8 110 = CLK_SYS / 12 111 = CLK_SYS / 16
R14 (0Eh) Clock Control3	5	CLK_OP_ENA	0	Clock Output Enable 0 = Disabled 1 = Enabled This bit enables OPCLK output on the MCLK pin. Frequency is set by CLK_OP_DIV.

Table 39 OPCLK Control

FREQUENCY LOCKED LOOP (FLL)

The integrated FLL can be used to generate CLK_SYS from a wide variety of different reference sources and frequencies. The FLL can use either MCLK, BCLK or LRCLK as its reference, which may be a high frequency (eg. 12.288MHz) or low frequency (eg. 32.768kHz) reference. The FLL is tolerant of jitter and may be used to generate a stable CLK_SYS from a less stable input signal. The FLL characteristics are summarised in “Electrical Characteristics”.

Note that the FLL can be used to generate a free-running clock in the absence of an external reference source. This is described in the “Free-Running FLL Clock” section below.

The FLL is enabled using the FLL_ENA register bit. Note that, when changing FLL settings, it is recommended that the digital circuit be disabled via FLL_ENA and then re-enabled after the other register settings have been updated. When changing the input reference frequency F_{REF} , it is recommended that the FLL be reset by setting FLL_ENA to 0.

The field FLL_CLK_REF_DIV provides the option to divide the input reference (MCLK, BCLK or LRCLK) by 1, 2, 4 or 8. This field should be set to bring the reference down to 13.5MHz or below. For best performance, it is recommended that the highest possible frequency - within the 13.5MHz limit - should be selected.

The field FLL_CTRL_RATE controls internal functions within the FLL; it is recommended that only the default setting be used for this parameter. FLL_GAIN controls the internal loop gain and should be set to the recommended value.

The FLL output frequency is directly determined from FLL_FRATIO, FLL_OUTDIV and the real number represented by FLL_N and FLL_K. The field FLL_N is an integer (LSB = 1); FLL_K is the fractional portion of the number (MSB = 0.5). The fractional portion is only valid when enabled by the field FLL_FRAC. It is recommended that FLL_FRAC is enabled at all times.

The FLL output frequency is generated according to the following equation:

$$F_{OUT} = (F_{VCO} / FLL_OUTDIV)$$

The FLL operating frequency, F_{VCO} is set according to the following equation:

$$F_{VCO} = (F_{REF} \times N.K \times FLL_FRATIO)$$

F_{REF} is the input frequency, as determined by FLL_CLK_REF_DIV.

F_{VCO} must be in the range 90-100 MHz. Frequencies outside this range cannot be supported.

Note that the output frequencies that do not lie within the ranges quoted above cannot be guaranteed across the full range of device operating temperatures.

In order to follow the above requirements for F_{VCO} , the value of FLL_OUTDIV should be selected according to the desired output F_{OUT} , as described in Table 40.

OUTPUT FREQUENCY F_{OUT}	FLL_OUTDIV
2.8125 MHz - 3.125 MHz	4h (divide by 32)
5.625 MHz - 6.25 MHz	3h (divide by 16)
11.25 MHz - 12.5 MHz	2h (divide by 8)
22.5 MHz - 25 MHz	1h (divide by 4)

Table 40 Selection of FLL_OUTDIV

The value of FLL_FRATIO should be selected as described in Table 41.

REFERENCE FREQUENCY F_{REF}	FLL_FRATIO
1MHz - 13.5MHz	0h (divide by 1)
256kHz - 1MHz	1h (divide by 2)
128kHz - 256kHz	2h (divide by 4)
64kHz - 128kHz	3h (divide by 8)
Less than 64kHz	4h (divide by 16)

Table 41 Selection of FLL_FRATIO

In order to determine the remaining FLL parameters, the FLL operating frequency, F_{VCO} , must be calculated, as given by the following equation:

$$F_{VCO} = (F_{OUT} \times FLL_OUTDIV)$$

The value of FLL_N and FLL_K can then be determined as follows:

$$N.K = F_{VCO} / (FLL_FRATIO \times F_{REF})$$

Note that F_{REF} is the input frequency, after division by FLL_CLK_REF_DIV, where applicable.

For best performance, FLL Fractional Mode should always be used. Therefore, if the calculations yield an integer value of N.K, then it is recommended to adjust FLL_FRATIO in order to obtain a non-integer value of N.K.

The register fields that control the FLL are described in Table 42. Example settings for a variety of reference frequencies and output frequencies are shown in Table 43.

REGISTER ADDRESS	BIT	LABEL	DEFAULT	DESCRIPTION
R16 (10h) FLL Control 1	3	FLL_HOLD	0	FLL Hold Select 0 = Disabled 1 = Enabled This feature enables free-running mode in FLL when reference clock is removed
	2	FLL_FRAC	0	Fractional enable 0 = Integer Mode 1 = Fractional Mode Fractional Mode is recommended in all cases
	0	FLL_ENA	0	FLL Enable 0 = Disabled 1 = Enabled
R17 (11h) FLL Control 2	10:8	FLL_OUTDIV [2:0]	010	F_{OUT} clock divider 000 = 2 001 = 4 010 = 8 011 = 16 100 = 32 101 = 64 110 = 128 111 = 256 ($F_{OUT} = F_{VCO} / FLL_OUTDIV$)
	6:4	FLL_CTRL_RATE [2:0]	000	Frequency of the FLL control block 000 = $F_{VCO} / 1$ (Recommended value) 001 = $F_{VCO} / 2$ 010 = $F_{VCO} / 3$ 011 = $F_{VCO} / 4$ 100 = $F_{VCO} / 5$ 101 = $F_{VCO} / 6$ 110 = $F_{VCO} / 7$ 111 = $F_{VCO} / 8$ Recommended that this register is not changed from default.

REGISTER ADDRESS	BIT	LABEL	DEFAULT	DESCRIPTION
	2:0	FLL_FRATIO [2:0]	000	<p>F_{VCO} clock divider</p> <p>000 = 1 001 = 2 010 = 4 011 = 8 1XX = 16</p> <p>000 recommended for high F_{REF} 011 recommended for low F_{REF}</p>
R18 (12h) FLL Control 3	15:0	FLL_K[15:0]	0000_0000 _0000_0000 0	Fractional multiply for F_{REF} (MSB = 0.5)
R19 (13h) FLL Control 4	14:5	FLL_N[9:0]	00_0001_0 000	Integer multiply for F_{REF} (LSB = 1)
	3:0	FLL_GAIN [3:0]	0100	<p>Gain applied to error</p> <p>0000 = x 1 (Recommended value) 0001 = x 2 0010 = x 4 0011 = x 8 0100 = x 16 0101 = x 32 0110 = x 64 0111 = x 128 1000 = x 256</p> <p>Recommended that this register is not changed from default.</p>
R20 (14h) FLL Control 5	4:3	FLL_CLK_REF_DIV [1:0]	00	<p>FLL Clock Reference Divider</p> <p>00 = MCLK / 1 01 = MCLK / 2 10 = MCLK / 4 11 = MCLK / 8</p> <p>MCLK (or other input reference) must be divided down to ≤ 13.5MHz. For lower power operation, the reference clock can be divided down further if desired.</p>
	1:0	FLL_CLK_SRC [1:0]	00	<p>FLL Clock source</p> <p>00 - BCLK 01 - MCLK 10 - LRCLK 11 = Reserved</p>

Table 42 FLL Register Map

FREE-RUNNING FLL CLOCK

The FLL can generate a clock signal even when no external reference is available. However, it should be noted that the accuracy of this clock is reduced, and a reference source should always be used where possible. Note that, in free-running modes, the FLL is not sufficiently accurate for hi-fi audio applications. However, the free-running modes are suitable for clocking other functions, including the Write Sequencer and Class D loudspeaker driver. The free-running mode can be used to support the analogue (DAC bypass) audio path.

A clock reference is required for initial configuration of the FLL as described above. For free-running operation, the FLL_HOLD bit should be set, as described in Table 42. When FLL_HOLD is set, the FLL will continue to generate a stable output clock after the reference input is stopped or disconnected.

EXAMPLE FLL CALCULATION

To generate 12.288 MHz output (F_{OUT}) from a 12.000 MHz reference clock (F_{REF}):

- Set FLL_CLK_REF_DIV in order to generate $F_{REF} \leq 13.5\text{MHz}$:
FLL_CLK_REF_DIV = 00 (divide by 1)
- Set FLL_CTRL_RATE to the recommended setting:
FLL_CTRL_RATE = 000 (divide by 1)
- Set FLL_GAIN to the recommended setting:
FLL_GAIN = 0000 (multiply by 1)
- Set FLL_OUTDIV for the required output frequency as shown in Table 40:-
 $F_{OUT} = 12.288\text{ MHz}$, therefore FLL_OUTDIV = 2h (divide by 8)
- Set FLL_FRATIO for the given reference frequency as shown in Table 41:
 $F_{REF} = 12\text{MHz}$, therefore FLL_FRATIO = 0h (divide by 1)
- Calculate F_{VCO} as given by $F_{VCO} = F_{OUT} \times FLL_OUTDIV$:-
 $F_{VCO} = 12.288 \times 8 = 98.304\text{MHz}$
- Calculate N.K as given by $N.K = F_{VCO} / (FLL_FRATIO \times F_{REF})$:
 $N.K = 98.304 / (1 \times 12) = 8.192$
- Determine FLL_N and FLL_K from the integer and fractional portions of N.K:-
FLL_N is 8. FLL_K is 0.192
- Confirm that N.K is a fractional quantity and set FLL_FRAC:
N.K is fractional. Set FLL_FRAC = 1.
Note that, if N.K is an integer, then an alternative value of FLL_FRATIO should be selected in order to produce a fractional value of N.K.

EXAMPLE FLL SETTINGS

Table 43 provides example FLL settings for generating common CLK_SYS frequencies from a variety of low and high frequency reference inputs.

F _{REF}	F _{OUT}	FLL_CLK_REF_DIV	F _{VCO}	FLL_N	FLL_K	FLL_FRATIO	FLL_OUTDIV	FLL_FRAC
32.000 kHz	12.288 MHz	0h (divide by 1)	98.304 MHz	384 (180h)	0 (0000h)	8 (3h)	8 (2h)	0
32.000 kHz	11.2896 MHz	0h (divide by 1)	90.3168 MHz	352 (160h)	0.8 (CCCCCh)	8 (3h)	8 (2h)	1
32.768 kHz	12.288 MHz	0h (divide by 1)	98.304 MHz	187 (0BBh)	0.5 (8000h)	16 (4h)	8 (2h)	1
32.768 kHz	11.288576 MHz	0h (divide by 1)	90.308608 MHz	344 (158h)	0.5 (8000h)	8 (3h)	8 (2h)	1
32.768 kHz	11.2896 MHz	0h (divide by 1)	90.3168 MHz	344 (158h)	0.53125 (8800h)	8 (3h)	8 (2h)	1
48 kHz	12.288 MHz	0h (divide by 1)	98.304 MHz	256 (100h)	0 (0000h)	8 (3h)	8 (2h)	0
11.3636 MHz	12.368544 MHz	0h (divide by 1)	98.948354 MHz	8 (008h)	0.707483 (B51Dh)	1 (0h)	8 (2h)	1
12.000 MHz	12.288 MHz	0h (divide by 1)	98.3040 MHz	8 (008h)	0.192 (3127h)	1 (0h)	8 (2h)	1
12.000 MHz	11.289597 MHz	0h (divide by 1)	90.3168 MHz	7 (007h)	0.526398 (86C2h)	1 (0h)	8 (2h)	1
12.288 MHz	12.288 MHz	0h (divide by 1)	98.304 MHz	8 (008h)	0 (0000h)	1 (0h)	8 (2h)	0
12.288 MHz	11.2896 MHz	0h (divide by 1)	90.3168 MHz	7 (007h)	0.35 (599Ah)	1 (0h)	8 (2h)	1
13.000 MHz	12.287990 MHz	0h (divide by 1)	98.3040 MHz	7 (007h)	0.56184 (8FD5h)	1 (0h)	8 (2h)	1
13.000 MHz	11.289606 MHz	0h (divide by 1)	90.3168 MHz	6 (006h)	0.94745 (F28Ch)	1 (0h)	8 (2h)	1
19.200 MHz	12.287988 MHz	1h (divide by 2)	98.3039 MHz	5 (005h)	0.119995 (1EB8h)	1 (0h)	8 (2h)	1
19.200 MHz	11.289588 MHz	1h (divide by 2)	90.3168 MHz	4 (004h)	0.703995 (B439h)	1 (0h)	8 (2h)	1

Table 43 Example FLL Settings

THERMAL SHUTDOWN

The WM9081 incorporates a temperature sensor which detects when the device temperature is within normal limits or if the device is approaching a hazardous temperature condition. The TEMP_SHUT flag can be polled at any time to determine the temperature status. The temperature status can also be indicated via the IRQ pin.

The temperature sensor is configured by default to automatically disable the audio outputs of the WM9081 in response to an over-temperature condition.

The temperature sensor is enabled when the TSENSE_ENA register bit is set. When the TSHUT_ENA bit is also set, then a device over-temperature condition will cause the speaker output to be disabled; this response is intended to prevent any damage to the device attributable to the large currents of the output drivers.

See "Interrupts" for details of hardware output of the Temperature Sensor status via the IRQ pin.

REGISTER ADDRESS	BIT	LABEL	DEFAULT	DESCRIPTION
R11 (0Bh) Power Management	8	TSHUT_ENA	1	Thermal shutdown control (Causes audio outputs to be disabled if an over-temperature occurs. The thermal sensor must also be enabled.) 0 = Disabled 1 = Enabled
	7	TSENSE_ENA	1	Thermal sensor enable 0 = Disabled 1 = Enabled
	6	TEMP_SHUT	0	Thermal Sensor status (Read Only) 0 = Temperature limit not exceeded 1 = Temperature limit exceeded

Table 44 Thermal Shutdown

INTERRUPTS

The interrupt controller has two inputs; these are the Temperature Sensor and the Control Write Sequencer. Any combination of these inputs can be used to trigger an Interrupt (IRQ) event.

There is an Interrupt Status field associated with each of the IRQ inputs. These are listed within the Interrupt Status Register, R26 (1Ah), as described in Table 45. The status of the IRQ inputs can be read at any time from this register or else in response to the interrupt event being signalled via the IRQ pin.

Individual mask bits can select or deselect different functions from the Interrupt controller. These are listed within the Interrupt Status Mask Register, R27 (1Bh), as described in Table 45. Note that the status fields remain valid, even when masked, but the masked bits will not cause the IRQ to be asserted.

The interrupt output represents the logical 'OR' of all the unmasked IRQ inputs. Each bit within the Interrupt Status register R26 (1Ah) is a latching bit - once it is set, it remains at logic 1 even if the trigger condition is cleared. The interrupt status bits are cleared by writing a logic 1 to the relevant register bit. Accordingly, the IRQ output is not reset until each of the unmasked IRQ inputs has been reset.

When the temperature sensor is used as an interrupt event, the polarity can be set using TSHUT_INV. This allows the IRQ event to be used to indicate either the normal temperature condition or the over-temperature condition. Under default conditions (TSHUT_INV = 0), the interrupt will be triggered in response to an over-temperature condition.

By default, the IRQ output is Active Low. The polarity can be inverted using IRQ_POL. The IRQ output may be configured as either CMOS or Open-Drain type. In Open Drain mode, a logic 1 is asserted by tri-stating the IRQ pin, rather than pulling it high. An external pull-up resistor is required to pull the IRQ high so that the logic 1 can be recognised by another device.

The WM9081 Interrupt Controller circuit is illustrated in Figure 54. The associated control fields are described in Table 45. Note that CLK_SYS is required for the interrupt circuit.

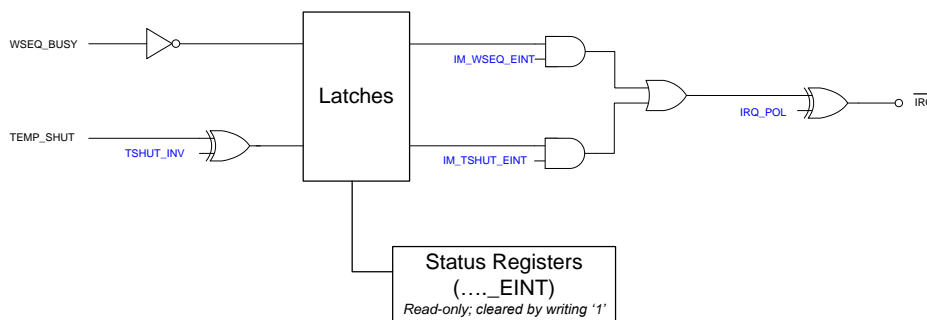

Figure 54 Interrupt Controller

REGISTER ADDRESS	BIT	LABEL	DEFAULT	DESCRIPTION
R26 (1Ah) Interrupt Status	2	WSEQ_BUSY_EINT	0	Write Sequencer Interrupt 0 = Interrupt not set 1 = Interrupt is set The Write Sequencer asserts this flag when it has completed a programmed sequence - ie it indicates that the Write Sequencer is NOT Busy. It is cleared when a '1' is written.
	0	TSHUT_EINT	0	Thermal Shutdown Interrupt 0 = Interrupt not set 1 = Interrupt is set This flag is asserted a thermal shutdown condition has been detected. It is cleared when a '1' is written.
R27 (1Bh) Interrupt Status Mask	2	IM_WSEQ_BUSY_EINT	1	Write Sequencer interrupt mask 0 = do not mask interrupt 1 = mask interrupt
	0	IM_TSHUT_EINT	0	Thermal Shutdown interrupt mask 0 = do not mask interrupt 1 = mask interrupt
R28 (1Ch) Interrupt Polarity	0	TSHUT_INV	0	Thermal Shutdown interrupt polarity 0 = active low (interrupt is triggered when temperature threshold is exceeded) 1 = active high (interrupt is triggered when temperature is normal)
R29 (1Dh) Interrupt Control	15	IRQ_POL	0	Interrupt output polarity 0 = Active low 1 = Active high
	0	IRQ_OP_CTRL	0	IRQ Output pin configuration 0 = CMOS 1 = Open Drain

Table 45 Interrupt Control

REFERENCE VOLTAGES AND MASTER BIAS

This section describes the analogue reference voltage and bias current controls. It also describes the VMID soft-start circuit for pop suppressed start-up and shut-down. Note that, under the recommended usage conditions of the WM9081, these features will be configured by running the default control sequences as described in the “Control Write Sequencer” section. In these cases, the user does not need to set these register fields directly.

The analogue circuits in the WM9081 require a mid-rail analogue reference voltage, VMID. This reference is generated from AVDD via a programmable resistor chain. Together with the external VMID decoupling capacitor, the programmable resistor chain results in a slow, normal, or fast charging characteristic on VMID. This is controlled by VMID_SEL[1:0], and can be used to optimise the reference for normal operation, low power standby or for fast start-up as described in Table 46.

The analogue circuits in the WM9081 require a bias current. The normal bias current is enabled by setting BIAS_ENA. Note that the normal bias current source requires VMID to be enabled also.

REGISTER ADDRESS	BIT	LABEL	DEFAULT	DESCRIPTION
R4 (04h) VMID Control	2:1	VMID_SEL [1:0]	00	VMID Divider Enable and Select 00 = VMID disabled (for OFF mode) 01 = 2 x 40kΩ divider (for normal operation) 10 = 2 x 240kΩ divider (for low power standby) 11 = 2 x 5kΩ divider (for fast start-up)
R5 (05h) Bias Control 1	1	BIAS_ENA	0	Enables the Normal bias current generator (for all analogue functions) 0 = Disabled 1 = Enabled

Table 46 Reference Voltages and Master Bias Enable

A pop-suppressed start-up requires VMID to be enabled smoothly, without the step change normally associated with the initial stage of the VMID capacitor charging. A pop-suppressed start-up also requires the analogue bias current to be enabled throughout the signal path prior to the VMID reference voltage being applied. The WM9081 incorporates pop-suppression circuits which address these requirements.

An alternate bias current source (Start-Up Bias) is provided for pop-free start-up; this is enabled by the STARTUP_BIAS_ENA register bit. The start-up bias is selected (in place of the normal bias) using the BIAS_SRC bit. It is recommended that the start-up bias is used during start-up, before switching back to the higher quality, normal bias.

A soft-start circuit is provided in order to control the switch-on of the VMID reference. The soft-start control circuit offers two slew rates for enabling the VMID reference. The soft-start feature is selected by setting VMID_RAMP; the slew rate is controlled by VMID_FAST_ST. When the soft-start circuit is enabled prior to enabling VMID_SEL, the reference voltage rises smoothly, without the step change that would otherwise occur. It is recommended that the soft-start circuit and the output signal path be enabled before VMID is enabled by VMID_SEL.

A soft shut-down is provided, using the soft-start control circuit and the start-up bias current generator. The soft shut-down of VMID is achieved by setting VMID_RAMP, STARTUP_BIAS_ENA and BIAS_SRC to select the start-up bias current and soft-start circuit prior to setting VMID_SEL=00. The slew rate is controlled by VMID_FAST_ST.

The VMID soft-start register controls are defined in Table 47.

REGISTER ADDRESS	BIT	LABEL	DEFAULT	DESCRIPTION
R4 (04h) VMID Control	3	VMID_RAMP	0	VMID Soft Start control 0 = Normal 1 = Soft Start
	0	VMID_FAST_ST	1	VMID Slew Rate control 0 = Slow 1 = Fast
R5 (05h) Bias Control 1	6	BIAS_SRC	1	Selects the bias current source 0 = Normal bias 1 = Start-Up bias
	0	STARTUP_BIAS_ENA	0	Enables the Start-Up bias current generator 0 = Disabled 1 = Enabled

Table 47 Soft Start Control

The master bias current is configurable using the BIAS_LVL register. This enables power consumption to be reduced under selected operating conditions. The normal bias current is recommended for all active operating modes.

If a low power standby configuration is required, (for example, if the WM9081 is powered up and configured, but is not actually generating an audio output), then the master bias may be switched to a standby level, enabling further reduction in power consumption. The standby bias level is enabled using STBY_BIAS_ENA and is configured using STBY_BIAS_LVL, as described in Table 48.

REGISTER ADDRESS	BIT	LABEL	DEFAULT	DESCRIPTION
R5 (05h) Bias Control 1	5	STBY_BIAS_LVL	1	Standby bias current select 0 = Normal bias x 0.5 1 = Normal bias x 0.25
	4	STBY_BIAS_ENA	0	Selects the Standby bias level 0 = Disabled (Bias set by BIAS_LVL) 1 = Enabled (Bias set by STBY_BIAS_LVL)
	3:2	BIAS_LVL [1:0]	10	Master bias current select 00 = Normal bias x 0.5 01 = Normal bias x 0.75 10 = Normal bias 11 = Normal bias x 1.5

Table 48 Master Bias Level Control

POWER MANAGEMENT

The WM9081 has many control registers that allow users to select which functions are active. For minimum power consumption, unused functions should be disabled. To minimise pop or click noise, it is important to enable or disable functions in the correct order. Note that, under the recommended usage conditions of the WM9081, these features will be configured by running the default control sequences as described in the “Control Write Sequencer” section. In these cases, many of these register fields will be configured automatically.

REGISTER ADDRESS	BIT	LABEL	DEFAULT	DESCRIPTION
R4 (04h) VMID Control	2:1	VMID_SEL [1:0]	00	VMID Divider Enable and Select 00 = VMID disabled (for OFF mode) 01 = 2 x 40kΩ divider (for normal operation) 10 = 2 x 240kΩ divider (for low power standby) 11 = 2 x 5kΩ divider (for fast start-up)
R5 (05h) Bias Control 1	1	BIAS_ENA	0	Enables the Normal bias current generator (for all analogue functions) 0 = Disabled 1 = Enabled
R11 (0Bh) Power Management	8	TSHUT_ENA	1	Thermal shutdown control (Causes audio outputs to be disabled if an over-temperature occurs. The thermal sensor must also be enabled.) 0 = Disabled 1 = Enabled
	7	TSENSE_ENA	1	Thermal sensor enable 0 = Disabled 1 = Enabled
	4	LINEOUT_ENA	0	LINEOUT Enable 0 = Disabled 1 = Enabled
	2	SPKPGA_ENA	0	Speaker PGA Enable 0 = Disabled 1 = Enabled
	1	SPK_ENA	0	Speaker Output Enable 0 = Disabled 1 = Enabled
	0	DAC_ENA	0	DAC Enable 0 = Disabled 1 = Enabled
R14 (0Eh) Clock Control 3	5	CLK_OP_ENA	0	Clock Output Enable 0 = Disabled 1 = Enabled This bit enables OPCLK output on the MCLK pin. Frequency is set by CLK_OP_DIV.
	2	CLK_TO_ENA	0	TOCLK (timeout/ slow clock) Enable 0 = Disabled 1 = Enabled
	1	CLK_DSP_ENA	0	CLK_DSP enable 0 = Disabled 1 = Enabled

REGISTER ADDRESS	BIT	LABEL	DEFAULT	DESCRIPTION
	0	CLK_SYS_ENA	0	CLK_SYS enable 0 = Disabled 1 = Enabled
R16 (10h) FLL Control 1	0	FLL_ENA	0	FLL Enable 0 = Disabled 1 = Enabled
R32 (20h) DRC1	15	DRC_ENA	0	DRC enable 0 = Disabled 1 = Enabled
R38 (26h) Write Sequencer 1	15	WSEQ_ENA	0	Write Sequencer Enable. 0 = Disabled 1 = Enabled
R42 (2Ah) EQ1	0	EQ_ENA	0	EQ Enable 0 = Disabled 1 = Enabled

Table 49 Power Management

CHIP RESET AND ID

The device ID can be read back from register 0. Writing to this register will reset the device.

REGISTER ADDRESS	BIT	LABEL	DEFAULT	DESCRIPTION
R0 (00h) Software Reset	15:0	SW_RST_DEV_ID [15:0]	9081h	Writing to this register resets all registers to their default state. Reading from this register will indicate device family ID 9081h.

Table 50 Chip Reset and ID

REGISTER MAP

Reg	Name	15	14	13	12	11	10	9	8	7	6	5	4	3	2	1	0	Default		
R0 (0h)	Software Reset								SW_RST_DEV_ID[15:0]										0	000h
R2 (2h)	Analogue Lineout	0	0	0	0	0	0	0	0	0	0	0	0	0	0	0	0	008h		
R3 (3h)	Analogue Speaker PGA	0	0	0	0	0	0	0	0	0	0	0	0	0	0	0	0	008h		
R4 (4h)	VIMD Control	0	0	0	0	0	0	0	0	0	0	0	0	0	0	0	0	000h		
R5 (5h)	Bias Control 1	0	0	0	0	0	0	0	0	0	0	0	0	0	0	0	0	008h		
R7 (7h)	Analogue Mixer	0	0	0	0	0	0	0	0	0	0	0	0	0	0	0	0	000h		
R8 (8h)	Anti Pop Control	0	0	0	0	0	0	0	0	0	0	0	0	0	0	0	0	000h		
R9 (9h)	Analogue Speaker 1	0	0	0	0	0	0	0	0	0	0	0	0	0	0	0	0	000h		
R10 (Ah)	Analogue Speaker 2	0	0	0	0	0	0	0	0	0	0	0	0	0	0	0	0	018h		
R11 (Bh)	Power Management	0	0	0	0	0	0	0	0	0	0	0	0	0	0	0	0	018h		
R12 (Ch)	Clock Control 1	0	0	0	0	0	0	0	0	0	0	0	0	0	0	0	0	000h		
R13 (Dh)	Clock Control 2	0	0	0	0	0	0	0	0	0	0	0	0	0	0	0	0	003h		
R14 (Eh)	Clock Control 3	0	0	0	0	0	0	0	0	0	0	0	0	0	0	0	0	000h		
R16 (10h)	FLL Control 1	0	0	0	0	0	0	0	0	0	0	0	0	0	0	0	0	000h		
R17 (11h)	FLL Control 2	0	0	0	0	0	0	0	0	0	0	0	0	0	0	0	0	020h		
R18 (12h)	FLL Control 3								FLL_N[15:0]										000h	
R19 (13h)	FLL Control 4								FLL_N9[0]										024h	
R20 (14h)	FLL Control 5	0	0	0	0	0	0	0	0	0	0	0	0	0	0	0	0	000h		
R22 (16h)	Audio Interface 1	0	0	0	0	0	0	0	0	0	0	0	0	0	0	0	0	000h		
R23 (17h)	Audio Interface 2	0	0	0	0	0	0	0	0	0	0	0	0	0	0	0	0	000h		
R24 (18h)	Audio Interface 3	0	0	0	0	0	0	0	0	0	0	0	0	0	0	0	0	000h		
R25 (19h)	Audio Interface 4	0	0	0	0	0	0	0	0	0	0	0	0	0	0	0	0	002h		
R26 (1Ah)	Interrupt Status	0	0	0	0	0	0	0	0	0	0	0	0	0	0	0	0	000h		
R27 (1Bh)	Interrupt Status Mask	0	0	0	0	0	0	0	0	0	0	0	0	0	0	0	0	006h		
R28 (1Ch)	Interrupt Polarity	0	0	0	0	0	0	0	0	0	0	0	0	0	0	0	0	000h		
R29 (1Dh)	Interrupt Control	0	0	0	0	0	0	0	0	0	0	0	0	0	0	0	0	000h		
R30 (1Eh)	DAC Digital 1	0	0	0	0	0	0	0	0	0	0	0	0	0	0	0	0	002h		
R31 (1Fh)	DAC Digital 2	0	0	0	0	0	0	0	0	0	0	0	0	0	0	0	0	008h		
R32 (20h)	DRC1	0	0	0	0	0	0	0	0	0	0	0	0	0	0	0	0	000h		
R33 (21h)	DRC2								DRC_ATK[3:0]										000h	
R34 (22h)	DRC3	0	0	0	0	0	0	0	0	0	0	0	0	0	0	0	0	000h		
R35 (23h)	DRC4	0	0	0	0	0	0	0	0	0	0	0	0	0	0	0	0	000h		
R38 (26h)	Write Sequencer 1	0	0	0	0	0	0	0	0	0	0	0	0	0	0	0	0	000h		
R39 (27h)	Write Sequencer 2	0	0	0	0	0	0	0	0	0	0	0	0	0	0	0	0	000h		

Reg	Name	15	14	13	12	11	10	9	8	7	6	5	4	3	2	1	0	Default
R40 (28h)	MW Slave 1	0	0	0	0	0	0	0	0	0	0	SPL_CFG	SPL_WIRE	ARL_ENA	0	AUTO_INC	0	0002h
R42 (29h)	EQ 1	EQ_B1_GAN[F:0]																0000h
R43 (28h)	EQ 2	EQ_B5_GAN[F:0]																0000h
R44 (20h)	EQ 3	EQ_B1_A[15:0]																0FCAh
R45 (20h)	EQ 4	EQ_B1_B[15:0]																0400h
R46 (2Eh)	EQ 5	EQ_B1_Pq[15:0]																00B8h
R47 (2Fh)	EQ 6	EQ_B2_A[15:0]																1E85h
R48 (30h)	EQ 7	EQ_B2_B[15:0]																F145h
R49 (31h)	EQ 8	EQ_B2_C[15:0]																0B75h
R50 (32h)	EQ 9	EQ_B2_Pq[15:0]																01C5h
R51 (33h)	EQ 10	EQ_B3_A[15:0]																1B8Eh
R52 (34h)	EQ 11	EQ_B3_B[15:0]																F8E9h
R53 (35h)	EQ 12	EQ_B3_C[15:0]																07ADh
R54 (36h)	EQ 13	EQ_B3_Pq[15:0]																1103h
R55 (37h)	EQ 14	EQ_B4_A[15:0]																1C88h
R56 (38h)	EQ 15	EQ_B4_B[15:0]																F373h
R57 (39h)	EQ 16	EQ_B4_C[15:0]																04C4h
R58 (3Ah)	EQ 17	EQ_B4_Pq[15:0]																0C88h
R59 (3Bh)	EQ 18	EQ_B5_A[15:0]																0C64h
R60 (3Ch)	EQ 19	EQ_B5_B[15:0]																0C88h
R61 (3Dh)	EQ 20	EQ_B5_Pq[15:0]																4000h

REGISTER BITS BY ADDRESS

REGISTER ADDRESS	BIT	LABEL	DEFAULT	DESCRIPTION	REFER TO
R0 (00h) Software Reset	15:0	SW_RST_DEV_ID1[15:0]	9081h	Writing to this register resets all registers to their default state. Reading from this register will indicate device family ID 9081h.	Power Management

Register 00h Software Reset

REGISTER ADDRESS	BIT	LABEL	DEFAULT	DESCRIPTION	REFER TO
R2 (02h) Analogue Lineout	7	LINEOUT_MUTE	1	LINEOUT Mute 0 = Un-mute 1 = Mute	Signal Path Control
	6	LINEOUTZC	0	LINEOUT Zero Cross Detection 0 = Change gain immediately 1 = Change gain on zero cross only	Signal Path Control
	5:0	LINEOUT_VOL[5:0]	11_1001	LINEOUT Volume 00 0000 = -57dB 00 0001 = -56dB ... 11 1001 = 0dB ... 11 1111 = 6dB	Signal Path Control

Register 02h Analogue Lineout

REGISTER ADDRESS	BIT	LABEL	DEFAULT	DESCRIPTION	REFER TO
R3 (03h) Analogue Speaker PGA	7	SPKPGA_MUTE	1	Speaker PGA Mute 0 = Un-mute 1 = Mute	Signal Path Control
	6	SPKPGAZC	0	Speaker PGA Zero Cross Detection 0 = Change gain immediately 1 = Change gain on zero cross only	Signal Path Control
	5:0	SPKPGA_VOL[5:0]	11_1001	Speaker PGA Volume 00 0000 = -57dB 00 0001 = -56dB ... 11 1001 = 0dB ... 11 1111 = 6dB	Signal Path Control

Register 03h Analogue Speaker PGA

REGISTER ADDRESS	BIT	LABEL	DEFAULT	DESCRIPTION	REFER TO
R4 (04h) VMID Control	5	VMID_BUF_ENA	0	Enables VMID reference for lineout and inputs clamps 0 = Disabled 1 = Enabled	Pop Suppression Control
	3	VMID_RAMP	0	VMID Soft Start control	Reference Voltages and

REGISTER ADDRESS	BIT	LABEL	DEFAULT	DESCRIPTION	REFER TO
				0 = Normal 1 = Soft Start	master bias
	2:1	VMID_SEL[1:0]	00	VMID Divider Enable and Select 00 = VMID disabled (for OFF mode) 01 = 2 x 40kΩ divider (for normal operation) 10 = 2 x 240kΩ divider (for low power standby) 11 = 2 x 5kΩ divider (for fast start-up)	Reference Voltages and master bias Power Management
	0	VMID_FAST_ST	1	VMID Slew Rate control 0 = Slow 1 = Fast	Reference Voltages and master bias

Register 04h VMID Control

REGISTER ADDRESS	BIT	LABEL	DEFAULT	DESCRIPTION	REFER TO
R5 (05h) Bias Control 1	6	BIAS_SRC	1	Selects the bias current source 0 = Normal bias 1 = Start-Up bias	Reference Voltages and master bias
	5	STBY_BIAS_LVL	1	Standby bias current select 0 = Normal bias x 0.5 1 = Normal bias x 0.25	Reference Voltages and master bias
	4	STBY_BIAS_ENA	0	Selects the Standby bias level 0 = Disabled (Bias set by BIAS_LVL) 1 = Enabled (Bias set by STBY_BIAS_LVL)	Reference Voltages and master bias
	3:2	BIAS_LVL[1:0]	10	Master bias current select 00 = Normal bias x 0.5 01 = Normal bias x 0.75 10 = Normal bias 11 = Normal bias x 1.5	Reference Voltages and master bias
	1	BIAS_ENA	0	Enables the Normal bias current generator (for all analogue functions) 0 = Disabled 1 = Enabled	Reference Voltages and master bias Power Management
	0	STARTUP_BIAS_ENA	0	Enables the Start-Up bias current generator 0 = Disabled 1 = Enabled	Reference Voltages and master bias

Register 05h Bias Control 1

REGISTER ADDRESS	BIT	LABEL	DEFAULT	DESCRIPTION	REFER TO
R7 (07h) Analogue Mixer	4	DAC_SEL	0	DAC Path Enable 0 = Disabled 1 = Enabled	Signal Path Control
	3	IN2_VOL	0	IN2 Volume Control 0 = 0dB 1 = -6dB	Signal Path Control
	2	IN2_ENA	0	IN2 Path Enable 0 = Disabled 1 = Enabled	Signal Path Control

REGISTER ADDRESS	BIT	LABEL	DEFAULT	DESCRIPTION	REFER TO
	1	IN1_VOL	0	IN1 Volume Control 0 = 0dB 1 = -6dB	Signal Path Control
	0	IN1_ENA	0	IN1 Path Enable 0 = Disabled 1 = Enabled	Signal Path Control

Register 07h Analogue Mixer

REGISTER ADDRESS	BIT	LABEL	DEFAULT	DESCRIPTION	REFER TO
R8 (08h) Anti Pop Control	2	LINEOUT_DISC H	0	Discharges LINEOUT via approx 5kohm resistor 0 = Not active 1 = Actively discharging LINEOUT	Pop Suppression Control
	1	LINEOUT_VROI	0	Buffered VMID to LINEOUT Resistance. This applies when LINEOUT_ENA = 0 and LINEOUT_CLAMP = 1. 0 = 20kΩ from buffered VMID to output 1 = 500Ω from buffered VMID to output	Pop Suppression Control
	0	LINEOUT_CLAMP	0	Clamp LINEOUT to buffered VMID. VMID_BUF_ENA must be set. This bit is only effective when LINEOUT_ENA = 0. The resistance is set by LINEOUT_VROI. 0 = Disabled 1 = Enabled (LINEOUT clamped to VMID)	Pop Suppression Control

Register 08h Anti Pop Control

REGISTER ADDRESS	BIT	LABEL	DEFAULT	DESCRIPTION	REFER TO
R9 (09h) Analogue Speaker 1	5:3	SPK_DCGAIN[2:0]	011 (+3.6dB)	Speaker Output DC Gain 000 = x1 boost (0dB) 001 = x1.27 boost(2.1dB) 010 = x1.4 boost (2.9dB) 011 = x1.52 boost (3.6dB) 100 = x1.67 boost (4.5dB) 101 = x1.8 boost (5.1dB) 110-111 = Reserved	Analogue Outputs
	2:0	SPK_ACGAIN[2:0]	011 (+3.6dB)	Speaker Output AC Gain 000 = x1 boost (0dB) 001 = x1.27 boost(2.1dB) 010 = x1.4 boost (2.9dB) 011 = x1.52 boost (3.6dB) 100 = x1.67 boost (4.5dB) 101 = x1.8 boost (5.1dB) 110-111 = Reserved	Analogue Outputs

Register 09h Analogue Speaker 1

REGISTER ADDRESS	BIT	LABEL	DEFAULT	DESCRIPTION	REFER TO
R10 (0Ah) Analogue Speaker 2	6	SPK_MODE	0	Speaker Mode Select 0 = Class D mode 1 = Class AB mode	Analogue Outputs

REGISTER ADDRESS	BIT	LABEL	DEFAULT	DESCRIPTION	REFER TO
	4	SPK_INV_MUTE	1	Controls a pop-suppression circuit for Speaker start-up. Controlled automatically by SPK_ENA in Class D mode. Must be set to 0 before enabling SPK_ENA in Class AB mode. 0 = Normal operation 1 = SPK_INV_MUTE enabled	Signal Path Control
	3	OUT_SPK_CTRL	1	Controls a pop-suppression circuit for Speaker start-up. Controlled automatically by SPK_ENA in Class D mode. Must be set to 0 before enabling SPK_ENA in Class AB mode. 0 = Normal operation 1 = OUT_SPK_CTRL enabled	Signal Path Control

Register 0Ah Analogue Speaker 2

REGISTER ADDRESS	BIT	LABEL	DEFAULT	DESCRIPTION	REFER TO
R11 (0Bh) Power Management	8	TSHUT_ENA	1	Thermal shutdown control (Causes audio outputs to be disabled if an over-temperature occurs. The thermal sensor must also be enabled.) 0 = Disabled 1 = Enabled	Thermal Shutdown Power Management
	7	TSENSE_ENA	1	Thermal sensor enable 0 = Disabled 1 = Enabled	Thermal Shutdown Power Management
	6	TEMP_SHUT	0	Thermal Sensor status (Read Only) 0 = Temperature limit not exceeded 1 = Temperature limit exceeded	Thermal Shutdown
	4	LINEOUT_ENA	0	LINEOUT Enable 0 = Disabled 1 = Enabled	Signal Path Control Power Management
	2	SPKPGA_ENA	0	Speaker PGA Enable 0 = Disabled 1 = Enabled	Signal Path Control Power Management
	1	SPK_ENA	0	Speaker Output Enable 0 = Disabled 1 = Enabled	Signal Path Control Power Management
	0	DAC_ENA	0	DAC Enable 0 = Disabled 1 = Enabled	Digital to Analogue Converter (DAC) Power Management

Register 0Bh Power Management

REGISTER ADDRESS	BIT	LABEL	DEFAULT	DESCRIPTION	REFER TO
R12 (0Ch) Clock Control 1	12:10	CLK_OP_DIV[2:0]	000	OPCLK Clock Divider 000 = CLK_SYS 001 = CLK_SYS / 2 010 = CLK_SYS / 3 011 = CLK_SYS / 4 100 = CLK_SYS / 6 101 = CLK_SYS / 8 110 = CLK_SYS / 12 111 = CLK_SYS / 16	Clocking and Sample Rates
	9:8	CLK_TO_DIV[1:0]	00	TOCLK (timeout/ slow clock) frequency select 00 = 125Hz 01 = 250Hz 10 = 500Hz 11 = 1kHz	Clocking and Sample Rates
	7	MCLKDIV2	0	MCLK Divider 0 = MCLK 1 = MCLK / 2	Clocking and Sample Rates

Register 0Ch Clock Control 1

REGISTER ADDRESS	BIT	LABEL	DEFAULT	DESCRIPTION	REFER TO
R13 (0Dh) Clock Control 2	7:4	CLK_SYS_RATE[3:0]	0011	Selects the CLK_SYS / fs ratio 0000 = 64 0001 = 128 0010 = 192 0011 = 256 0100 = 384 0101 = 512 0110 = 768 0111 = 1024 1000 = 1408 1001 = 1536	Clocking and Sample Rates
	3:0	SAMPLE_RATE[3:0]	1000	Selects the Sample Rate (fs) 0000 = 8kHz 0001 = 11.025kHz 0010 = 12kHz 0011 = 16kHz 0100 = 22.05kHz 0101 = 24kHz 0110 = 32kHz 0111 = 44.1kHz 1000 = 48kHz 1001 = 88.2kHz 1010 = 96kHz 1011 to 1111 = Reserved	Clocking and Sample Rates

Register 0Dh Clock Control 2

REGISTER ADDRESS	BIT	LABEL	DEFAULT	DESCRIPTION	REFER TO
R14 (0Eh) Clock Control	13	CLK_SRC_SEL	0	CLK_SYS Source Select	Clocking and Sample

REGISTER ADDRESS	BIT	LABEL	DEFAULT	DESCRIPTION	REFER TO
3				0 = MCLK 1 = FLL output	Rates
	5	CLK_OP_ENA	0	Clock Output Enable 0 = Disabled 1 = Enabled This bit enables OPCLK output on the MCLK pin. Frequency is set by CLK_OP_DIV.	Clocking and Sample Rates Power Management
	2	CLK_TO_ENA	0	TOCLK (timeout/ slow clock) Enable 0 = Disabled 1 = Enabled	Clocking and Sample Rates Power Management
	1	CLK_DSP_ENA	0	CLK_DSP enable 0 = Disabled 1 = Enabled	Clocking and Sample Rates Power Management
	0	CLK_SYS_ENA	0	CLK_SYS enable 0 = Disabled 1 = Enabled	Clocking and Sample Rates Power Management

Register 0Eh Clock Control 3

REGISTER ADDRESS	BIT	LABEL	DEFAULT	DESCRIPTION	REFER TO
R16 (10h) FLL Control 1	3	FLL_HOLD	0	FLL Hold Select 0 = Disabled 1 = Enabled This feature enables free-running mode in FLL when reference clock is removed	Clocking and Sample Rates
	2	FLL_FRAC	0	Fractional enable 0 = Integer Mode 1 = Fractional Mode Fractional Mode is recommended in all cases	Clocking and Sample Rates
	0	FLL_ENA	0	FLL Enable 0 = Disabled 1 = Enabled	Clocking and Sample Rates Power Management

Register 10h FLL Control 1

REGISTER ADDRESS	BIT	LABEL	DEFAULT	DESCRIPTION	REFER TO
R17 (11h) FLL Control 2	10:8	FLL_OUTDIV[2:0]	010	F _{OUT} clock divider 000 = 2 001 = 4	Clocking and Sample Rates

REGISTER ADDRESS	BIT	LABEL	DEFAULT	DESCRIPTION	REFER TO
				010 = 8 011 = 16 100 = 32 101 = 64 110 = 128 111 = 256 $(F_{OUT} = F_{VCO} / FLL_OUTDIV)$	
	6:4	FLL_CTRL_RATE[2:0]	000	Frequency of the FLL control block 000 = $F_{VCO} / 1$ (Recommended value) 001 = $F_{VCO} / 2$ 010 = $F_{VCO} / 3$ 011 = $F_{VCO} / 4$ 100 = $F_{VCO} / 5$ 101 = $F_{VCO} / 6$ 110 = $F_{VCO} / 7$ 111 = $F_{VCO} / 8$ Recommended that this register is not changed from default.	Clocking and Sample Rates
	2:0	FLL_FRATIO[2:0]	000	F_{VCO} clock divider 000 = 1 001 = 2 010 = 4 011 = 8 1XX = 16 000 recommended for high F_{REF} 011 recommended for low F_{REF}	Clocking and Sample Rates

Register 11h FLL Control 2

REGISTER ADDRESS	BIT	LABEL	DEFAULT	DESCRIPTION	REFER TO
R18 (12h) FLL Control 3	15:0	FLL_K[15:0]	0000_0000 _0000_000 0	Fractional multiply for F_{REF} (MSB = 0.5)	Clocking and Sample Rates

Register 12h FLL Control 3

REGISTER ADDRESS	BIT	LABEL	DEFAULT	DESCRIPTION	REFER TO
R19 (13h) FLL Control 4	14:5	FLL_N[9:0]	00_0001_0 000	Integer multiply for F_{REF} (LSB = 1)	Clocking and Sample Rates
	3:0	FLL_GAIN[3:0]	0100	Gain applied to error 0000 = x 1 (Recommended value) 0001 = x 2 0010 = x 4 0011 = x 8 0100 = x 16 0101 = x 32 0110 = x 64	Clocking and Sample Rates

REGISTER ADDRESS	BIT	LABEL	DEFAULT	DESCRIPTION	REFER TO
				0111 = x 128 1000 = x 256 Recommended that this register is not changed from default.	

Register 13h FLL Control 4

REGISTER ADDRESS	BIT	LABEL	DEFAULT	DESCRIPTION	REFER TO
R20 (14h) FLL Control 5	4:3	FLL_CLK_REF_DIV[1:0]	00	FLL Clock Reference Divider 00 = MCLK / 1 01 = MCLK / 2 10 = MCLK / 4 11 = MCLK / 8 MCLK (or other input reference) must be divided down to <=13.5MHz. For lower power operation, the reference clock can be divided down further if desired.	Clocking and Sample Rates
	1:0	FLL_CLK_SRC[1:0]	00	FLL Clock source 00 - BCLK 01 - MCLK 10 - LRCLK 11 = Reserved	Clocking and Sample Rates

Register 14h FLL Control 5

REGISTER ADDRESS	BIT	LABEL	DEFAULT	DESCRIPTION	REFER TO
R22 (16h) Audio Interface 1	6	AIFDAC_CHAN	0	DAC Data Source Select 0 = DAC selects left channel data 1 = DAC selects right channel data	Digital audio interface control
	5:4	AIFDAC_TDM_SLOT[1:0]	00	DAC TDM Slot Select 00 = Select slot 0 (Left/Right) 01 = Select slot 1 (Left/Right) 10 = Select slot 2 (Left/Right) 11 = Select slot 3 (Left/Right)	Digital audio interface control
	3:2	AIFDAC_TDM_MODE[1:0]	00	DAC TDM Mode Select 00 = 1 stereo slot (TDM off) 01 = 2 stereo slots 10 = 3 stereo slots 11 = 4 stereo slots	Digital audio interface control
	1	DAC_COMP	0	DAC Companding Enable 0 = Disabled 1 = Enabled	Digital audio interface control
	0	DAC_COMPMODE	0	DAC Companding Type 0 = μ -law 1 = A-law	Digital audio interface control

Register 16h Audio Interface 1

REGISTER ADDRESS	BIT	LABEL	DEFAULT	DESCRIPTION	REFER TO
R23 (17h) Audio Interface 2	9	AIF_TRIS	0	Audio Interface Tristate 0 = Audio interface pins operate normally 1 = Tristate all audio interface pins	Digital audio interface control
	8	DAC_DAT_INV	0	DACDAT Invert 0 = DACDAT not inverted 1 = DACDAT inverted	Digital audio interface control
	7	AIF_BCLK_INV	0	BCLK Invert 0 = BCLK not inverted 1 = BCLK inverted	Digital audio interface control
	6	BCLK_DIR	0	BCLK Direction (Forces BCLK clock to be output in slave mode) 0 = BCLK normal operation 1 = BCLK clock output enabled	Digital audio interface control
	5	LRCLK_DIR	0	LRCLK Direction (Forces LRCLK clock to be output in slave mode) 0 = LRCLK normal operation 1 = LRCLK clock output enabled	Digital audio interface control
	4	AIF_LRCLK_INV	0	Right, left and I ² S modes – LRCLK polarity: 0 = normal LRCLK polarity 1 = invert LRCLK polarity DSP Mode – mode A/B select : 0 = MSB is available on 2nd BCLK rising edge after LRC rising edge (mode A) 1 = MSB is available on 1st BCLK rising edge after LRC rising edge (mode B)	Digital audio interface control
	3:2	AIF_WL[1:0]	00	Digital Audio Interface Word Length 00 = 16 bits 01 = 20 bits 10 = 24 bits 11 = 32 bits Note - see "Companding" for the selection of 8-bit mode.	Digital audio interface control
	1:0	AIF_FMT[1:0]	10	Digital Audio Interface Format 00 = Right justified 01 = Left justified 10 = I ² S Format 11 = DSP Mode	Digital audio interface control

Register 17h Audio Interface 2

REGISTER ADDRESS	BIT	LABEL	DEFAULT	DESCRIPTION	REFER TO
R24 (18h) Audio Interface 3	4:0	BCLK_DIV[4:0]	0_1000	BCLK Rate 00000 = CLK_SYS 00001 = CLK_SYS / 1.5 00010 = CLK_SYS / 2 00011 = CLK_SYS / 3 00100 = CLK_SYS / 4 00101 = CLK_SYS / 5 00110 = CLK_SYS / 5.5 00111 = CLK_SYS / 6 01000 = CLK_SYS / 8 01001 = CLK_SYS / 10	Digital audio interface control

REGISTER ADDRESS	BIT	LABEL	DEFAULT	DESCRIPTION	REFER TO
				01010 = CLK_SYS / 11 01011 = CLK_SYS / 12 01100 = CLK_SYS / 16 01101 = CLK_SYS / 20 01110 = CLK_SYS / 22 01111 = CLK_SYS / 24 10000 = CLK_SYS / 25 10001 = CLK_SYS / 30 10010 = CLK_SYS / 32 10011 = CLK_SYS / 44 10100 = CLK_SYS / 48	

Register 18h Audio Interface 3

REGISTER ADDRESS	BIT	LABEL	DEFAULT	DESCRIPTION	REFER TO
R25 (19h) Audio Interface 4	10:0	LRCLK_RATE[10:0]	000_0010_0010	LRCLK Rate LRCLK clock output = BCLK / LRCLK_RATE Integer (LSB = 1) Valid from 8..2047	Digital audio interface control

Register 19h Audio Interface 4

REGISTER ADDRESS	BIT	LABEL	DEFAULT	DESCRIPTION	REFER TO
R26 (1Ah) Interrupt Status	2	WSEQ_BUSY_EINT	0	Write Sequencer Interrupt 0 = Interrupt not set 1 = Interrupt is set The Write Sequencer asserts this flag when it has completed a programmed sequence - ie it indicates that the Write Sequencer is NOT Busy. It is cleared when a '1' is written.	Interrupts
	0	TSHUT_EINT	0	Thermal Shutdown Interrupt 0 = Interrupt not set 1 = Interrupt is set This flag is asserted a thermal shutdown condition has been detected. It is cleared when a '1' is written.	Interrupts

Register 1Ah Interrupt Status

REGISTER ADDRESS	BIT	LABEL	DEFAULT	DESCRIPTION	REFER TO
R27 (1Bh) Interrupt Status Mask	2	IM_WSEQ_BUSY_EINT	1	Write Sequencer interrupt mask 0 = do not mask interrupt 1 = mask interrupt	Interrupts
	0	IM_TSHUT_EINT	0	Thermal Shutdown interrupt mask 0 = do not mask interrupt 1 = mask interrupt	Interrupts

Register 1Bh Interrupt Status Mask

REGISTER ADDRESS	BIT	LABEL	DEFAULT	DESCRIPTION	REFER TO
R28 (1Ch) Interrupt Polarity	0	TSHUT_INV	0	Thermal Shutdown interrupt polarity 0 = active low (interrupt is triggered when temperature threshold is exceeded) 1 = active high (interrupt is triggered when temperature is normal)	Interrupts

Register 1Ch Interrupt Polarity

REGISTER ADDRESS	BIT	LABEL	DEFAULT	DESCRIPTION	REFER TO
R29 (1Dh) Interrupt Control	15	IRQ_POL	0	Interrupt output polarity 0 = Active low 1 = Active high	Interrupts
	0	IRQ_OP_CTRL	0	IRQ Output pin configuration 0 = CMOS 1 = Open Drain	Interrupts

Register 1Dh Interrupt Control

REGISTER ADDRESS	BIT	LABEL	DEFAULT	DESCRIPTION	REFER TO
R30 (1Eh) DAC Digital 1	7:0	DAC_VOL[7:0]	1100_0000	DAC Volume and MUTE 0000 0000 = MUTE 0000 0001 = -71.625dB ... in steps of 0.375dB to 1100 0000 = 0dB 1100 0001 to 1111 1111 = reserved	Digital to Analogue Converter (DAC)

Register 1Eh DAC Digital 1

REGISTER ADDRESS	BIT	LABEL	DEFAULT	DESCRIPTION	REFER TO
R31 (1Fh) DAC Digital 2	10	DAC_MUTERATE	0	DAC Soft Mute Ramp Rate 0 = Fast ramp (fs/2, maximum ramp time is 10.7ms at fs=48k) 1 = Slow ramp (fs/32, maximum ramp time is 171ms at fs=48k) (Note: ramp rate scales with sample rate.)	Digital to Analogue Converter (DAC)
	9	DAC_MUTEMODE	0	DAC Unmute Ramp select 0 = Disabling soft-mute (DAC_MUTE=0) will cause the DAC volume to change immediately to the DAC_VOL setting. 1 = Disabling soft-mute (DAC_MUTE=0) will cause the DAC volume to ramp up gradually to the DAC_VOL setting.	Digital to Analogue Converter (DAC)
	3	DAC_MUTE	1	DAC Soft Mute Control 0 = DAC Un-mute 1 = DAC Mute	Digital to Analogue Converter (DAC)
	2:1	DEEMPH[1:0]	00	DAC De-Emphasis Control 00 = No de-emphasis 01 = 32kHz sample rate 10 = 44.1kHz sample rate	Digital to Analogue Converter (DAC)

REGISTER ADDRESS	BIT	LABEL	DEFAULT	DESCRIPTION	REFER TO
				11 = 48kHz sample rate	

Register 1Fh DAC Digital 2

REGISTER ADDRESS	BIT	LABEL	DEFAULT	DESCRIPTION	REFER TO
R32 (20h) DRC 1	15	DRC_ENA	0	DRC enable 0 = Disabled 1 = Enabled	Dynamic Range Controller (DRC) Power Management
	10:6	DRC_STARTUP_GAIN[4:0]	0_0110	Initial gain at DRC startup 00000 = -3dB 00001 = -2.5dB 00010 = -2dB 00011 = -1.5dB 00100 = -1dB 00101 = -0.5dB 00110 = 0dB (default) 00111 = 0.5dB 01000 = 1dB 01001 = 1.5dB 01010 = 2dB 01011 = 2.5dB 01100 = 3dB 01101 = 3.5dB 01110 = 4dB 01111 = 4.5dB 10000 = 5dB 10001 = 5.5dB 10010 = 6dB 10011 to 11111 = Reserved	Dynamic Range Controller (DRC)
	5	DRC_FF_DLY	1	Feed-forward delay for anti-clip feature 0 = 5 samples 1 = 9 samples Time delay can be calculated as $5/f_s$ or $9/f_s$, where f_s is the sample rate.	Dynamic Range Controller (DRC)
	2	DRC_QR	1	Quick release enable 0 = Disabled 1 = Enabled	Dynamic Range Controller (DRC)
	1	DRC_ANTICLIP	1	Anti-clip enable 0 = Disabled 1 = Enabled	Dynamic Range Controller (DRC)

Register 20h DRC 1

REGISTER ADDRESS	BIT	LABEL	DEFAULT	DESCRIPTION	REFER TO
R33 (21h) DRC 2	15:12	DRC_ATK[3:0]	0100	Gain attack rate (seconds/6dB) 0000 = Reserved (181us)	Dynamic Range Controller

REGISTER ADDRESS	BIT	LABEL	DEFAULT	DESCRIPTION	REFER TO
				0001 = 181us 0010 = 363us 0011 = 726us 0100 = 1.45ms (default) 0101 = 2.9ms 0110 = 5.8ms 0111 = 11.6ms 1000 = 23.2ms 1001 = 46.4ms 1010 = 92.8ms 1011 = 185.6ms 1100-1111 = Reserved	(DRC)
	11:8	DRC_DCY[3:0]	0010	Gain decay rate (seconds/6dB) 0000 = 186ms 0001 = 372ms 0010 = 743ms (default) 0011 = 1.49s 0100 = 2.97s 0101 = 5.94s 0110 = 11.89s 0111 = 23.78s 1000 = 47.56s 1001-1111 = Reserved	Dynamic Range Controller (DRC)
	7:6	DRC_QR_THR[1:0]	00	Quick release crest factor threshold 00 = 12dB (default) 01 = 18dB 10 = 24dB 11 = 30dB	Dynamic Range Controller (DRC)
	5:4	DRC_QR_DCY[1:0]	00	Quick release decay rate (seconds/6dB) 00 = 0.725ms (default) 01 = 1.45ms 10 = 5.8ms 11 = Reserved	Dynamic Range Controller (DRC)
	3:2	DRC_MINGAIN[1:0]	00	Minimum gain the DRC can use to attenuate audio signals 00 = 0dB (default) 01 = -6dB 10 = -12dB 11 = -18dB	Dynamic Range Controller (DRC)
	1:0	DRC_MAXGAIN[1:0]	01	Maximum gain the DRC can use to boost audio signals 00 = 12dB 01 = 18dB (default) 10 = 24dB 11 = 36dB	Dynamic Range Controller (DRC)

Register 21h DRC 2

REGISTER ADDRESS	BIT	LABEL	DEFAULT	DESCRIPTION	REFER TO
R34 (22h) DRC 3	5:3	DRC_HI_COMP[2:0]	000	Compressor slope (upper region) 000 = 1 (no compression) 001 = 1/2 010 = 1/4	Dynamic Range Controller (DRC)

REGISTER ADDRESS	BIT	LABEL	DEFAULT	DESCRIPTION	REFER TO
				011 = 1/8 100 = 1/16 101 = 0 110 = Reserved 111 = Reserved	
	2:0	DRC_LO_COMP[2:0]	000	Compressor slope (lower region) 000 = 1 (no compression) 001 = 1/2 010 = 1/4 011 = 1/8 100 = 0 101 = Reserved 11X = Reserved	Dynamic Range Controller (DRC)

Register 22h DRC 3

REGISTER ADDRESS	BIT	LABEL	DEFAULT	DESCRIPTION	REFER TO
R35 (23h) DRC 4	10:5	DRC_KNEE_IP[5:0]	00_0000	Input signal level at the Compressor 'knee'. 000000 = 0dB 000001 = -0.75dB 000010 = -1.5dB ... (-0.75dB steps) 111100 = -45dB 111101 = Reserved 11111X = Reserved	Dynamic Range Controller (DRC)
	4:0	DRC_KNEE_OP[4:0]	0_0000	Output signal at the Compressor 'knee'. 00000 = 0dB 00001 = -0.75dB 00010 = -1.5dB ... (-0.75dB steps) 11110 = -22.5dB 11111 = Reserved	Dynamic Range Controller (DRC)

Register 23h DRC 4

REGISTER ADDRESS	BIT	LABEL	DEFAULT	DESCRIPTION	REFER TO
R38 (26h) Write Sequencer 1	15	WSEQ_ENA	0	Write Sequencer Enable. 0 = Disabled 1 = Enabled	Control Write sequencer Power Management
	9	WSEQ_ABORT	0	Writing a 1 to this bit aborts the current sequence and returns control of the device back to the serial control interface.	Control Write sequencer
	8	WSEQ_START	0	Writing a 1 to this bit starts the write sequencer at the memory location indicated by the WSEQ_START_INDEX field. The sequence continues until it reaches an "End of sequence" flag. At the end of the sequence, this bit will be reset by the Write Sequencer.	Control Write sequencer
	6:0	WSEQ_START_	000_0000	Sequence Start Index. This is the memory location of the	Control Write

REGISTER ADDRESS	BIT	LABEL	DEFAULT	DESCRIPTION	REFER TO
		INDEX[6:0]		first command in the selected sequence.	sequencer

Register 26h Write Sequencer 1

REGISTER ADDRESS	BIT	LABEL	DEFAULT	DESCRIPTION	REFER TO
R39 (27h) Write Sequencer 2	10:4	WSEQ_CURRE NT_INDEX[6:0]	000_0000	Sequence Current Index. This is the location of the most recently accessed command in the write sequencer memory.	Control Write sequencer
	0	WSEQ_BUSY	0	Sequencer Busy flag (Read Only). 0 = Sequencer idle 1 = Sequencer busy Note: it is not possible to write to control registers via the control interface while the Sequencer is Busy.	Control Write sequencer

Register 27h Write Sequencer 2

REGISTER ADDRESS	BIT	LABEL	DEFAULT	DESCRIPTION	REFER TO
R40 (28h) MW Slave 1	5	SPI_CFG	0	Controls the SDOUT pin in 4 wire mode 0 = SDOUT output is CMOS 1 = SDOUT output is open drain	Control Interface (software mode)
	4	SPI_4WIRE	0	Selects 3-wire or 4-wire mode 0 = 3-wire mode using bi-directional SDIN pin 1 = 4-wire mode using SDOUT	Control Interface (software mode)
	3	ARA_ENA	0	Alert Response Address protocol enable 0 = Disabled 1 = Enabled	Control Interface (software mode)
	1	AUTO_INC	1	Enable Auto-Increment function 0 = Disabled 1 = Enabled	Control Interface (software mode)

Register 28h MW Slave 1

REGISTER ADDRESS	BIT	LABEL	DEFAULT	DESCRIPTION	REFER TO
R42 (2Ah) EQ 1	15:11	EQ_B1_GAIN[4: 0]	0_0000	EQ Band 1 Gain 00000 = -12dB 00001 = -11dB 11000 = +12dB	ReTune Mobile Parametric Equalizer (EQ)
	10:6	EQ_B2_GAIN[4: 0]	0_0000	EQ Band 2 Gain 00000 = -12dB 00001 = -11dB 11000 = +12dB	ReTune Mobile Parametric Equalizer (EQ)
	5:1	EQ_B3_GAIN[4: 0]	0_0000	EQ Band 3 Gain 00000 = -12dB 00001 = -11dB 11000 = +12dB	ReTune Mobile Parametric Equalizer (EQ)

REGISTER ADDRESS	BIT	LABEL	DEFAULT	DESCRIPTION	REFER TO
	0	EQ_ENA	0	EQ Enable 0 = Disabled 1 = Enabled	ReTune Mobile Parametric Equalizer (EQ) Power Management

Register 2Ah EQ 1

REGISTER ADDRESS	BIT	LABEL	DEFAULT	DESCRIPTION	REFER TO
R43 (2Bh) EQ 2	15:11	EQ_B4_GAIN[4:0]	0_0000	EQ Band 4 Gain 00000 = -12dB 00001 = -11dB 11000 = +12dB	ReTune Mobile Parametric Equalizer (EQ)
	10:6	EQ_B5_GAIN[4:0]	0_0000	EQ Band 5 Gain 00000 = -12dB 00001 = -11dB 11000 = +12dB	ReTune Mobile Parametric Equalizer (EQ)

Register 2Bh EQ 2

REGISTER ADDRESS	BIT	LABEL	DEFAULT	DESCRIPTION	REFER TO
R44 (2Ch) EQ 3	15:0	EQ_B1_A[15:0]	0000_1111 _1100_101 0	5 Band EQ Band 1 coefficient A	ReTune Mobile Parametric Equalizer (EQ)

Register 2Ch EQ 3

REGISTER ADDRESS	BIT	LABEL	DEFAULT	DESCRIPTION	REFER TO
R45 (2Dh) EQ 4	15:0	EQ_B1_B[15:0]	0000_0100 _0000_000 0	5 Band EQ Band 1 coefficient B	ReTune Mobile Parametric Equalizer (EQ)

Register 2Dh EQ 4

REGISTER ADDRESS	BIT	LABEL	DEFAULT	DESCRIPTION	REFER TO
R46 (2Eh) EQ 5	15:0	EQ_B1_PG[15:0]	0000_0000 _1011_100 0	5 Band EQ Band 1 coefficient PG	ReTune Mobile Parametric Equalizer (EQ)

Register 2Eh EQ 5

REGISTER ADDRESS	BIT	LABEL	DEFAULT	DESCRIPTION	REFER TO
R47 (2Fh) EQ 6	15:0	EQ_B2_A[15:0]	0001_1110 _1011_010 1	5 Band EQ Band 2 coefficient A	ReTune Mobile Parametric Equalizer (EQ)

Register 2Fh EQ 6

REGISTER ADDRESS	BIT	LABEL	DEFAULT	DESCRIPTION	REFER TO
R48 (30h) EQ 7	15:0	EQ_B2_B[15:0]	1111_0001 _0100_010 1	5 Band EQ Band 2 coefficient B	ReTune Mobile Parametric Equalizer (EQ)

Register 30h EQ 7

REGISTER ADDRESS	BIT	LABEL	DEFAULT	DESCRIPTION	REFER TO
R49 (31h) EQ 8	15:0	EQ_B2_C[15:0]	0000_1011 _0111_010 1	5 Band EQ Band 2 coefficient C	ReTune Mobile Parametric Equalizer (EQ)

Register 31h EQ 8

REGISTER ADDRESS	BIT	LABEL	DEFAULT	DESCRIPTION	REFER TO
R50 (32h) EQ 9	15:0	EQ_B2_PG[15:0]	0000_0001 _1100_010 1	5 Band EQ Band 2 coefficient PG	ReTune Mobile Parametric Equalizer (EQ)

Register 32h EQ 9

REGISTER ADDRESS	BIT	LABEL	DEFAULT	DESCRIPTION	REFER TO
R51 (33h) EQ 10	15:0	EQ_B3_A[15:0]	0001_0110 _1001_111 0	5 Band EQ Band 3 coefficient A	ReTune Mobile Parametric Equalizer (EQ)

Register 33h EQ 10

REGISTER ADDRESS	BIT	LABEL	DEFAULT	DESCRIPTION	REFER TO
R52 (34h) EQ 11	15:0	EQ_B3_B[15:0]	1111_1000 _0010_100 1	5 Band EQ Band 3 coefficient B	ReTune Mobile Parametric Equalizer (EQ)

Register 34h EQ 11

REGISTER ADDRESS	BIT	LABEL	DEFAULT	DESCRIPTION	REFER TO
R53 (35h) EQ 12	15:0	EQ_B3_C[15:0]	0000_0111 _1010_110 1	5 Band EQ Band 3 coefficient C	ReTune Mobile Parametric Equalizer (EQ)

Register 35h EQ 12

REGISTER ADDRESS	BIT	LABEL	DEFAULT	DESCRIPTION	REFER TO
R54 (36h) EQ 13	15:0	EQ_B3_PG[15:0]]	0001_0001 _0000_001 1	5 Band EQ Band 3 coefficient PG	ReTune Mobile Parametric Equalizer (EQ)

Register 36h EQ 13

REGISTER ADDRESS	BIT	LABEL	DEFAULT	DESCRIPTION	REFER TO
R55 (37h) EQ 14	15:0	EQ_B4_A[15:0]	0001_1100 _0101_100 0	5 Band EQ Band 4 coefficient A	ReTune Mobile Parametric Equalizer (EQ)

Register 37h EQ 14

REGISTER ADDRESS	BIT	LABEL	DEFAULT	DESCRIPTION	REFER TO
R56 (38h) EQ 15	15:0	EQ_B4_B[15:0]	1111_0011 _0111_001 1	5 Band EQ Band 4 coefficient B	ReTune Mobile Parametric Equalizer (EQ)

Register 38h EQ 15

REGISTER ADDRESS	BIT	LABEL	DEFAULT	DESCRIPTION	REFER TO
R57 (39h) EQ 16	15:0	EQ_B4_C[15:0]	0000_1010 _0101_010 0	5 Band EQ Band 4 coefficient C	ReTune Mobile Parametric Equalizer (EQ)

Register 39h EQ 16

REGISTER ADDRESS	BIT	LABEL	DEFAULT	DESCRIPTION	REFER TO
R58 (3Ah) EQ 17	15:0	EQ_B4_PG[15:0]]	0000_0101 _0101_100 0	5 Band EQ Band 2 coefficient PG	ReTune Mobile Parametric Equalizer

REGISTER ADDRESS	BIT	LABEL	DEFAULT	DESCRIPTION	REFER TO
					(EQ)

Register 3Ah EQ 17

REGISTER ADDRESS	BIT	LABEL	DEFAULT	DESCRIPTION	REFER TO
R59 (3Bh) EQ 18	15:0	EQ_B5_A[15:0]	0000_0101 _0110_010 0	5 Band EQ Band 5 coefficient A	ReTune Mobile Parametric Equalizer (EQ)

Register 3Bh EQ 18

REGISTER ADDRESS	BIT	LABEL	DEFAULT	DESCRIPTION	REFER TO
R60 (3Ch) EQ 19	15:0	EQ_B5_B[15:0]	0000_0101 _0101_100 1	5 Band EQ Band 5 coefficient B	ReTune Mobile Parametric Equalizer (EQ)

Register 3Ch EQ 19

REGISTER ADDRESS	BIT	LABEL	DEFAULT	DESCRIPTION	REFER TO
R61 (3Dh) EQ 20	15:0	EQ_B5_PG[15:0]	0100_0000 _0000_000 0	5 Band EQ Band 5 coefficient PG	ReTune Mobile Parametric Equalizer (EQ)

Register 3Dh EQ 20

DIGITAL FILTER CHARACTERISTICS

PARAMETER	TEST CONDITIONS	MIN	TYP	MAX	UNIT
DAC Normal Filter					
Passband	+/- 0.05dB	0		0.454 fs	
	-6dB		0.5 fs		
Passband Ripple	0.454 fs			+/- 0.03	dB
Stopband		0.546 fs			
Stopband Attenuation	F > 0.546 fs	-50			dB
DAC Sloping Stopband Filter					
Passband	+/- 0.03dB	0		0.25 fs	
	+/- 1dB	0.25 fs		0.454 fs	
	-6dB		0.5 fs		
Passband Ripple	0.25 fs			+/- 0.03	dB
Stopband 1		0.546 fs		0.7 fs	
Stopband 1 Attenuation	f > 0.546 fs	-60			dB
Stopband 2		0.7 fs		1.4 fs	
Stopband 2 Attenuation	f > 0.7 fs	-85			dB
Stopband 3		1.4 fs			
Stopband 3 Attenuation	F > 1.4 fs	-55			dB

DAC FILTER GROUP DELAY	
Mode	Group Delay
Normal	16.5 / fs
Sloping Stopband	18 / fs
4fs Mode	TBA

TERMINOLOGY

1. Stop Band Attenuation (dB) – the degree to which the frequency spectrum is attenuated (outside audio band)
2. Pass-band Ripple – any variation of the frequency response in the pass-band region

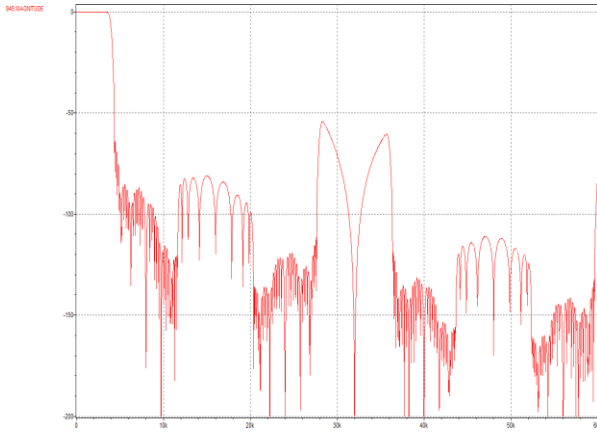
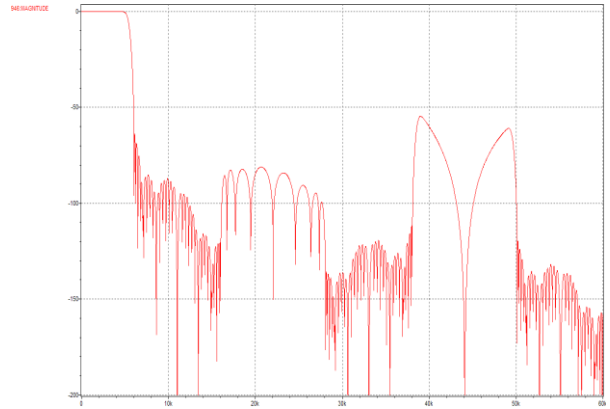
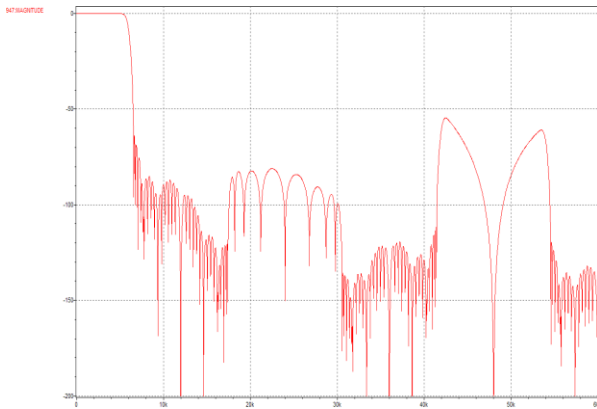
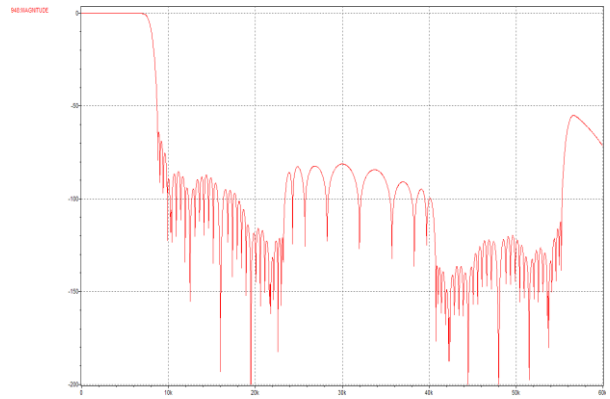
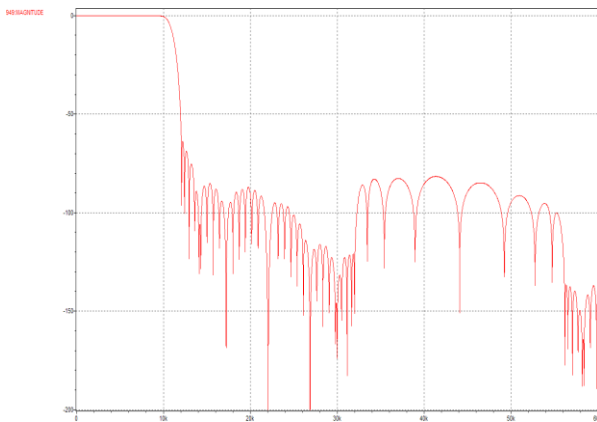
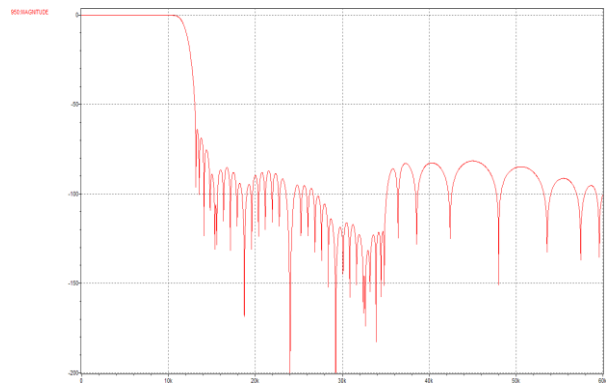
DAC FILTER RESPONSES

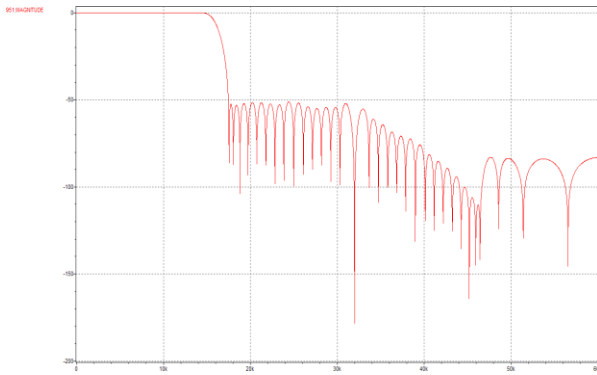
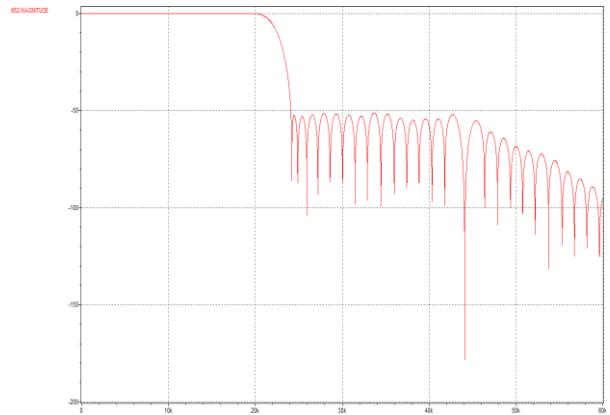
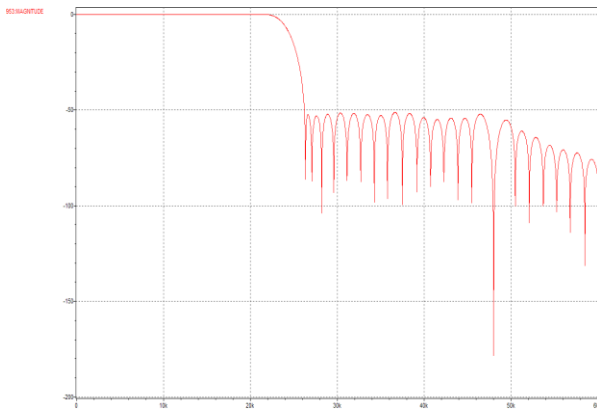
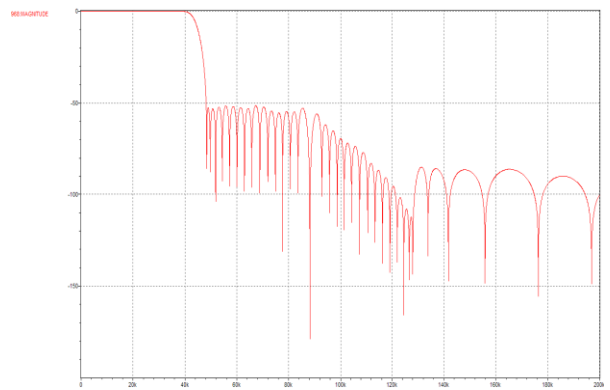
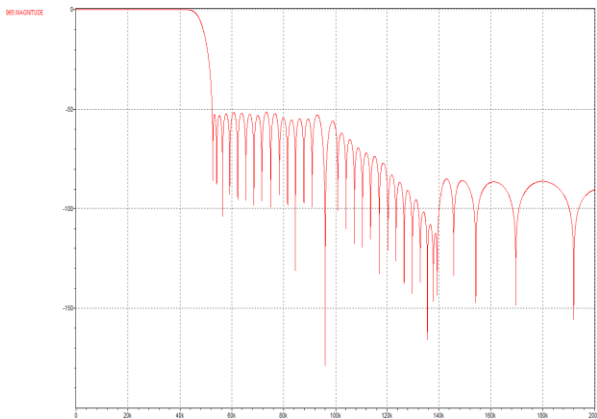
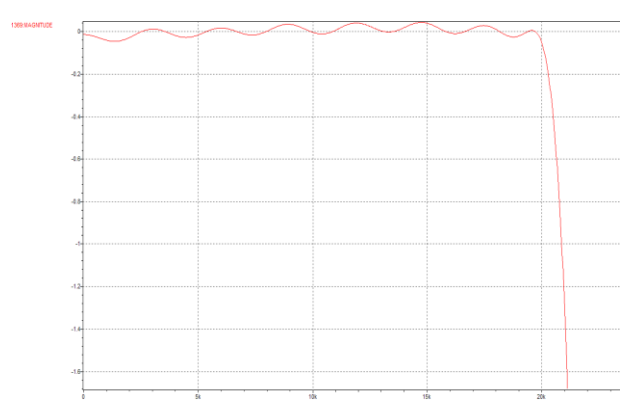
Figure 55 DAC Filter Response (fs=8kHz)

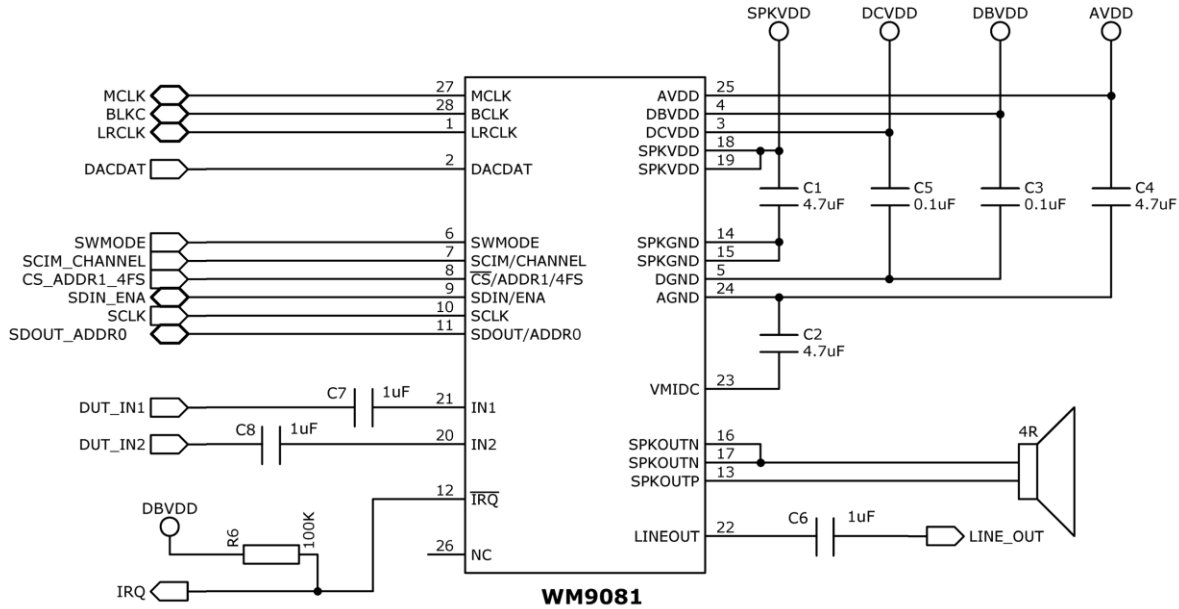
Figure 56 DAC Filter Response (fs=11.025kHz)

Figure 57 DAC Filter Response (fs=12kHz)

Figure 58 DAC Filter Response (fs=16kHz)

Figure 59 DAC Filter Response (fs=22.05kHz)

Figure 60 DAC Filter Response (fs=24kHz)

Figure 61 DAC Filter Response (fs=32kHz)

Figure 62 DAC Filter Response (fs=44.1kHz)

Figure 63 DAC Filter Response (fs=48kHz)

Figure 64 DAC Filter Response (fs=88.2kHz)

Figure 65 DAC Filter Response (fs=96kHz)

Figure 66 DAC Filter Passband Ripple (fs=44.1kHz)

APPLICATIONS INFORMATION
RECOMMENDED EXTERNAL COMPONENTS

Figure 67 Recommended external components
Notes

1. Cirrus Logic recommends using a single, common ground reference. Where this is not possible, care should be taken to optimise split ground configuration for audio performance.
2. Supply decoupling capacitors on DCVDD, DBVDD, SPKVDD and AVDD should be positioned as close to the WM9081 as possible.
3. Capacitor types should be chosen carefully. Capacitors with very low ESR are recommended for optimum performance.
4. The speakers should be connected as close as possible to the WM9081. When this is not possible, filtering should be placed on the speaker outputs close the WM9081.

SPEAKER SELECTION

For filterless operation, it is important to select a speaker with appropriate internal inductance. The internal inductance and the speaker's load resistance create a low-pass filter with a cut-off frequency of:

$$f_c = R_L / (2\pi L)$$

For an 4Ω speaker and required cut-off frequency of 20kHz, the speaker should be chosen to have an inductance of:

$$L = R_L / (2\pi f_c) = 4\Omega / (2\pi * 20\text{kHz}) = 32\mu\text{H}$$

Care should be taken to ensure that the cut-off frequency of the speaker's internal filtering is low enough to prevent speaker damage. The class D output of the WM9081 operate at much higher frequencies than is recommended for most speakers, and the cut-off frequency of the filter should be low enough to protect the speaker.

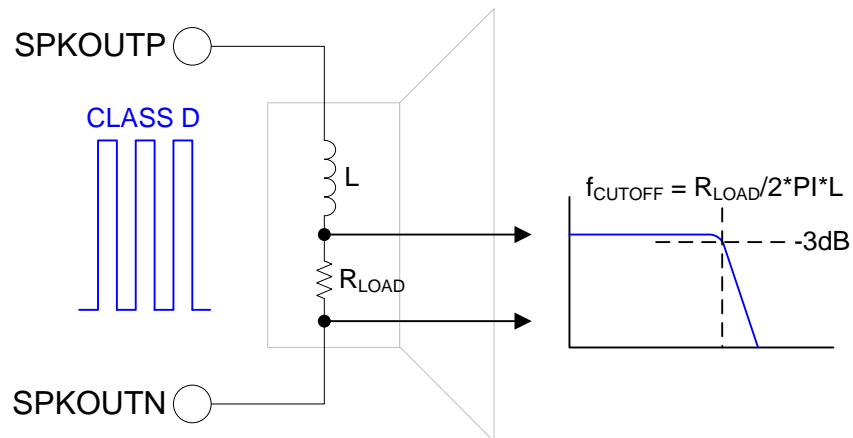

Figure 68 Speaker Equivalent Circuit

Notes

1. For further information on speaker selection, refer to the application note WAN_0200 - *Speaker Selection for Class D output drivers*.

PCB LAYOUT CONSIDERATIONS

The efficiency of the speaker driver is affected by the series resistance between the WM9081 and the speaker (e.g. inductor ESR) as shown in Figure 69. This resistance should be as low as possible to maximise efficiency.

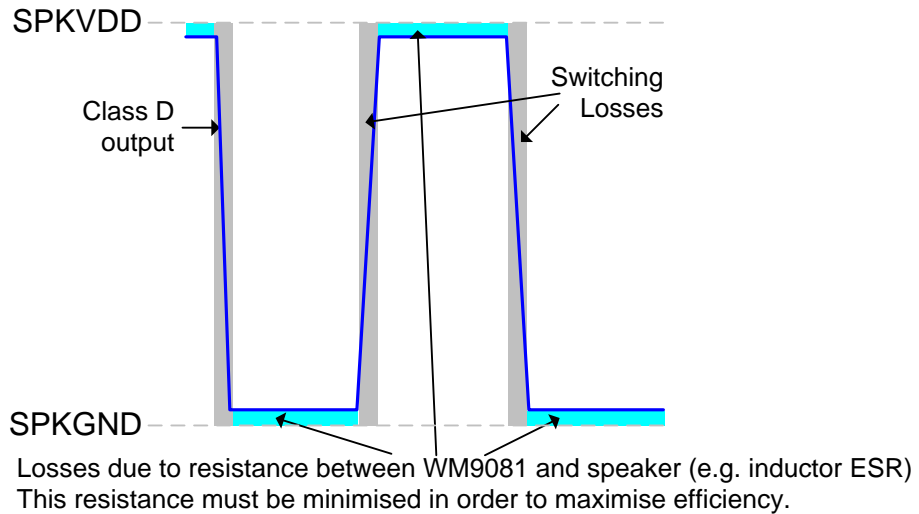

Figure 69 Speaker Connection Losses

The distance between the WM9081 and the speaker should be kept to a minimum to reduce series resistance, and also to reduce EMI. Further reductions in EMI can be achieved by additional passive filtering and/or shielding as shown in Figure 70. When additional passive filtering is used, low ESR components should be chosen to minimise series resistance between the WM9081 and the speaker, maximising efficiency.

LC passive filtering will usually be effective at reducing EMI at frequencies up to around 30MHz. To reduce emissions at higher frequencies, ferrite beads placed as close to the device as possible will be more effective.

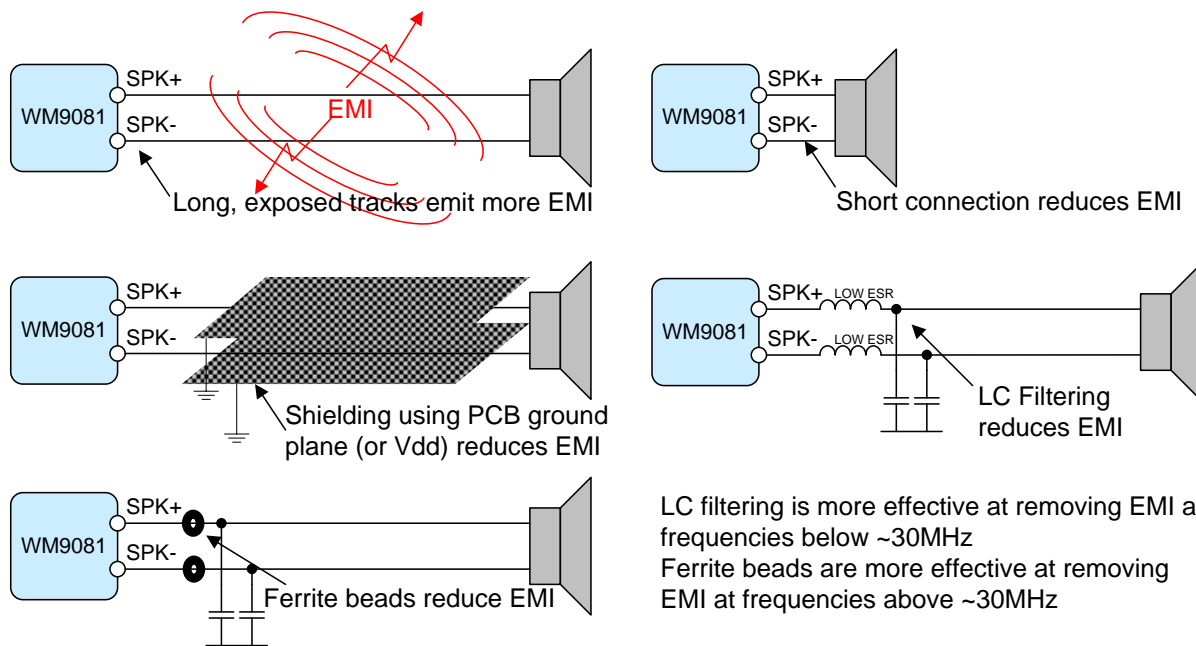
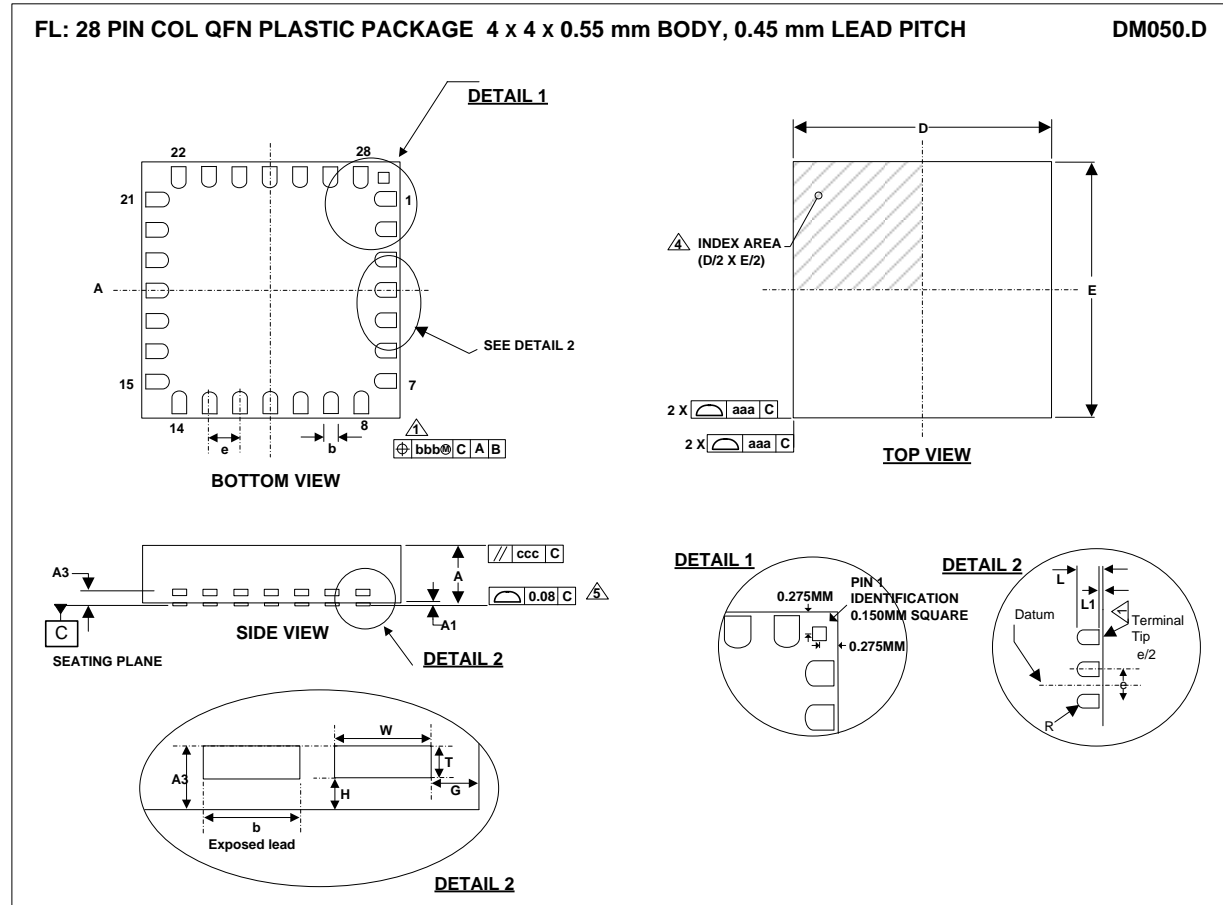

Figure 70 EMI Reduction Techniques

Refer to the application note WAN_0118 - *Guidelines on How to Use QFN Packages and Create Associated PCB Footprints*.

PACKAGE DIMENSIONS

Symbols	Dimensions (mm)			NOTE
	MIN	NOM	MAX	
A	0.500	0.550	0.600	
A1	0	0.035	0.050	
A3		0.152 REF		
b	0.180	0.230	0.280	1
D	3.950	4.000	4.050	
E	3.950	4.000	4.050	
e		0.450 BSC		
G		0.200 REF		
H		0.075 REF		
L		0.400 REF		
L1		0.000 REF		5
T		0.077 REF		
W		0.150 REF		
Tolerances of Form and Position				
aaa		0.100		
bbb		0.100		
ccc		0.100		
REF:		JEDEC, MO-220		

NOTES:

1. DIMENSION b APPLIES TO METALLIZED TERMINAL AND IS MEASURED BETWEEN 0.15 mm AND 0.30 mm FROM TERMINAL TIP.
2. ALL DIMENSIONS ARE IN MILLIMETRES.
3. COPLANARITY APPLIES TO THE TERMINALS.
4. REFER TO APPLICATIONS NOTE WAN_0118 FOR FURTHER INFORMATION REGARDING PCB FOOTPRINTS AND QFN PACKAGE SOLDERING.
5. DEPENDING ON THE METHOD OF LEAD TERMINATION AT THE EDGE OF THE PACKAGE, PULL BACK ($L1$) MAY BE PRESENT.
6. THIS DRAWING IS SUBJECT TO CHANGE WITHOUT NOTICE.

IMPORTANT NOTICE

Contacting Cirrus Logic Support

For all product questions and inquiries, contact a Cirrus Logic Sales Representative.

To find one nearest you, go to www.cirrus.com.

For the purposes of our terms and conditions of sale, "Preliminary" or "Advanced" datasheets are non-final datasheets that include but are not limited to datasheets marked as "Target", "Advance", "Product Preview", "Preliminary Technical Data" and/or "Pre-production." Products provided with any such datasheet are therefore subject to relevant terms and conditions associated with "Preliminary" or "Advanced" designations. The products and services of Cirrus Logic International (UK) Limited; Cirrus Logic, Inc.; and other companies in the Cirrus Logic group (collectively either "Cirrus Logic" or "Cirrus") are sold subject to Cirrus Logic's terms and conditions of sale supplied at the time of order acknowledgment, including those pertaining to warranty, indemnification, and limitation of liability. Software is provided pursuant to applicable license terms. Cirrus Logic reserves the right to make changes to its products and specifications or to discontinue any product or service without notice. Customers should therefore obtain the latest version of relevant information from Cirrus Logic to verify that the information is current and complete. Testing and other quality control techniques are utilized to the extent Cirrus Logic deems necessary. Specific testing of all parameters of each device is not necessarily performed. In order to minimize risks associated with customer applications, the customer must use adequate design and operating safeguards to minimize inherent or procedural hazards. Cirrus Logic is not liable for applications assistance or customer product design. The customer is solely responsible for its selection and use of Cirrus Logic products. Use of Cirrus Logic products may entail a choice between many different modes of operation, some or all of which may require action by the user, and some or all of which may be optional. Nothing in these materials should be interpreted as instructions or suggestions to choose one mode over another. Likewise, description of a single mode should not be interpreted as a suggestion that other modes should not be used or that they would not be suitable for operation. Features and operations described herein are for illustrative purposes only.

CERTAIN APPLICATIONS USING SEMICONDUCTOR PRODUCTS MAY INVOLVE POTENTIAL RISKS OF DEATH, PERSONAL INJURY, OR SEVERE PROPERTY OR ENVIRONMENTAL DAMAGE ("CRITICAL APPLICATIONS"). CIRRUS LOGIC PRODUCTS ARE NOT DESIGNED, AUTHORIZED OR WARRANTED FOR USE IN PRODUCTS SURGICALLY IMPLANTED INTO THE BODY, AUTOMOTIVE SAFETY OR SECURITY DEVICES, NUCLEAR SYSTEMS, LIFE SUPPORT PRODUCTS OR OTHER CRITICAL APPLICATIONS. INCLUSION OF CIRRUS LOGIC PRODUCTS IN SUCH APPLICATIONS IS UNDERSTOOD TO BE FULLY AT THE CUSTOMER'S RISK AND CIRRUS LOGIC DISCLAIMS AND MAKES NO WARRANTY, EXPRESS, STATUTORY OR IMPLIED, INCLUDING THE IMPLIED WARRANTIES OF MERCHANTABILITY AND FITNESS FOR PARTICULAR PURPOSE, WITH REGARD TO ANY CIRRUS LOGIC PRODUCT THAT IS USED IN SUCH A MANNER. IF THE CUSTOMER OR CUSTOMER'S CUSTOMER USES OR PERMITS THE USE OF CIRRUS LOGIC PRODUCTS IN CRITICAL APPLICATIONS, CUSTOMER AGREES, BY SUCH USE, TO FULLY INDEMNIFY CIRRUS LOGIC, ITS OFFICERS, DIRECTORS, EMPLOYEES, DISTRIBUTORS AND OTHER AGENTS FROM ANY AND ALL LIABILITY, INCLUDING ATTORNEYS' FEES AND COSTS, THAT MAY RESULT FROM OR ARISE IN CONNECTION WITH THESE USES.

This document is the property of Cirrus Logic and by furnishing this information, Cirrus Logic grants no license, express or implied, under any patents, mask work rights, copyrights, trademarks, trade secrets or other intellectual property rights. Any provision or publication of any third party's products or services does not constitute Cirrus Logic's approval, license, warranty or endorsement thereof. Cirrus Logic gives consent for copies to be made of the information contained herein only for use within your organization with respect to Cirrus Logic integrated circuits or other products of Cirrus Logic, and only if the reproduction is without alteration and is accompanied by all associated copyright, proprietary and other notices and conditions (including this notice). This consent does not extend to other copying such as copying for general distribution, advertising or promotional purposes, or for creating any work for resale. This document and its information is provided "AS IS" without warranty of any kind (express or implied). All statutory warranties and conditions are excluded to the fullest extent possible. No responsibility is assumed by Cirrus Logic for the use of information herein, including use of this information as the basis for manufacture or sale of any items, or for infringement of patents or other rights of third parties. Cirrus Logic, Cirrus, the Cirrus Logic logo design, SoundClear, WISCE and SilentSwitch are among the trademarks of Cirrus Logic. Other brand and product names may be trademarks or service marks of their respective owners.

Copyright © 2008–2016 Cirrus Logic, Inc. All rights reserved.

REVISION HISTORY

DATE	REV	DESCRIPTION OF CHANGES	CHANGED BY
20/12/16	4.0	<ul style="list-style-type: none">• DACDAT set-up time to BCLK rising edge changed to min 10ns (Figure 3)• Package Drawing updated (POD 050.D)	CT PH

Mouser Electronics

Authorized Distributor

Click to View Pricing, Inventory, Delivery & Lifecycle Information:

[Cirrus Logic:](#)

[WM9081GICN/RV](#) [WM9081GICN/V](#)