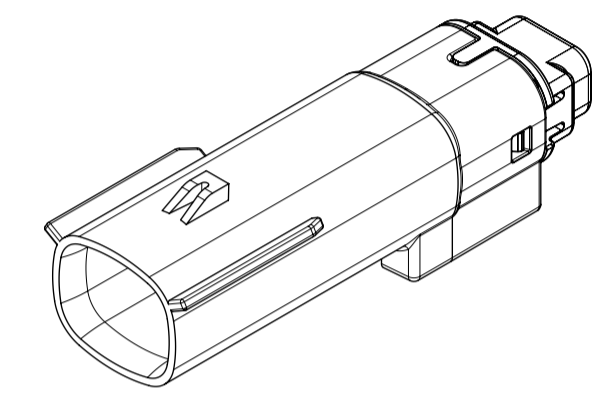

TABLE OF CONTENTS	
SHEET NO.	SHEET DESCRIPTION
1	NOTES AND BOM
2	CONFIGURATIONS
3-4	KEY CONFIGURATIONS
5	BLADE SEALED ASSEMBLY
6	SYSTEM PACKAGING
7	BACKSHELL NOTES
8	BACKSHELL
9	BACKSHELL CONFIGURATIONS

NOTES: VALID UNLESS OTHERWISE SPECIFIED

1. GENERAL:
- a. APPLICATION SPECIFICATION SEE: AS-33472-100
- CONTAINS: PRODUCT INTRODUCTION, PRODUCT SUMMARY, CONNECTOR ASSEMBLY, PACKAGING INFORMATION, CONNECTOR MATING, SERVICE INSTRUCTIONS, ELECTRICAL CONTINUITY CHECKING, CRIMPING, AND TROUBLESHOOTING.
  - DESIGNED TO MATE WITH RECEPTACLE SEALED ASSEMBLY AS SPECIFIED IN THE MATING CONNECTOR DRAWINGS CHART.
  - \*DENOTES DRAWINGS THAT CAN BE ACCESSED AT <http://ewcap.uscarteams.org/>
  - ASSEMBLY SHIPPED WITH PLR IN PRE-LOCK POSITION (SEE PLR PRE-LOCK VIEW SHEET 5).
- b. PRODUCT SPECIFICATION SEE:
- STANDARD CONFIGURATION: PS-33471-000
  - UL V0 CONFIGURATION: PS-160105-0001
  - CONTAINS: PRODUCT INTRODUCTION, PRODUCT SUMMARY, RATINGS (CURRENT, TEMPERATURE, SEALING, AND FLAMMABILITY), TERMINALS, WIRE DIAMETER RANGE, PRODUCT VALIDATION, AND PRODUCT DEVIATIONS.
- c. PACKAGING SPECIFICATION PER MOLEX DRAWING: PK-31300-635 (PK-33471-000 FOR 1X5)
- d. PARTS MUST BE IN COMPLIANCE TO MOLEX CHEMICAL SUBSTANCES FOR PRODUCTS AND PACKAGING SPECIFICATION: QEHS-699000-300
- e. DATA MUST BE SUBMITTED UNDER THE MOLEX PART NUMBER TO IMDS (COMPANY ID#13255)
2. DESIGN - MATERIALS:
- a. FOR BILL OF MATERIALS SEE:
- STANDARD CONFIGURATION: SD-33481-0002
  - UL V0 CONFIGURATION: SD-160106-0002
3. DESIGN - GEOMETRY:
- a. THE 3-D CAD DATA IS BASIC (WITHOUT TOLERANCE) AND MASTER FOR THIS PART WITH THE EXCEPTION OF UNDERLINED DIMENSIONS. DIMENSIONAL INFORMATION NOT SHOWN ON THIS DRAWING IS DEFINED BY THE DATA FILE AT ITS LATEST REVISION.
- b. GEOMETRIC DIMENSIONS AND TOLERANCES PER ASME Y14.5M-2009
- c. EDGES AND UNDIMENSIONED DETAILS PER ISO13715
- d. CORNERS SHOWN AS SHARP TO BE R 0.2 MAX.
- e. LETTERING SHALL BE 0.15 MAX RAISED IN 0.25 MAX RECESS PAD. THIS INCLUDES RECYCLING CODE, CAVITY ID, VENDOR IDENTIFICATION, AND CUSTOMER MATERIAL NUMBER.
- f. VISUAL DEFECTS SHALL MEET COSMETIC STANDARD PS-45499-002 (Class B).
- g. LASER MARKING:
1. PART NUMBER
  2. DAY OF THE YEAR
  3. SHIFT
  4. YEAR
- FOR ADDITIONAL INFORMATION SEE SECTION 5 UNDER PROCEDURES IN ES-34735-008.

MATING CONNECTOR DRAWINGS	
DESCRIPTION	MOLEX INLINE
1X2	SD-33471-0001
1X6	SD-33471-0001



1X2

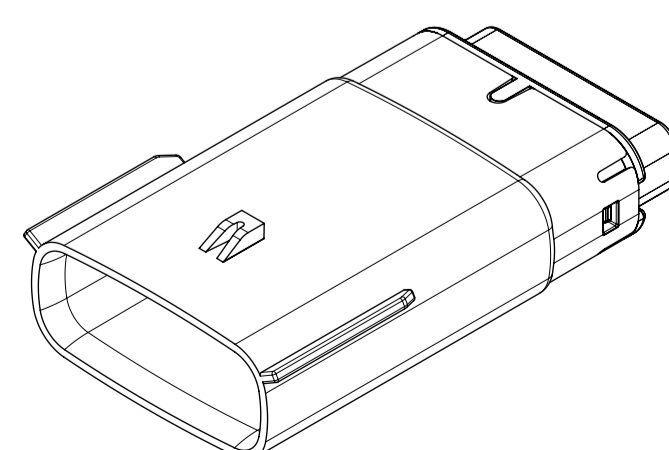
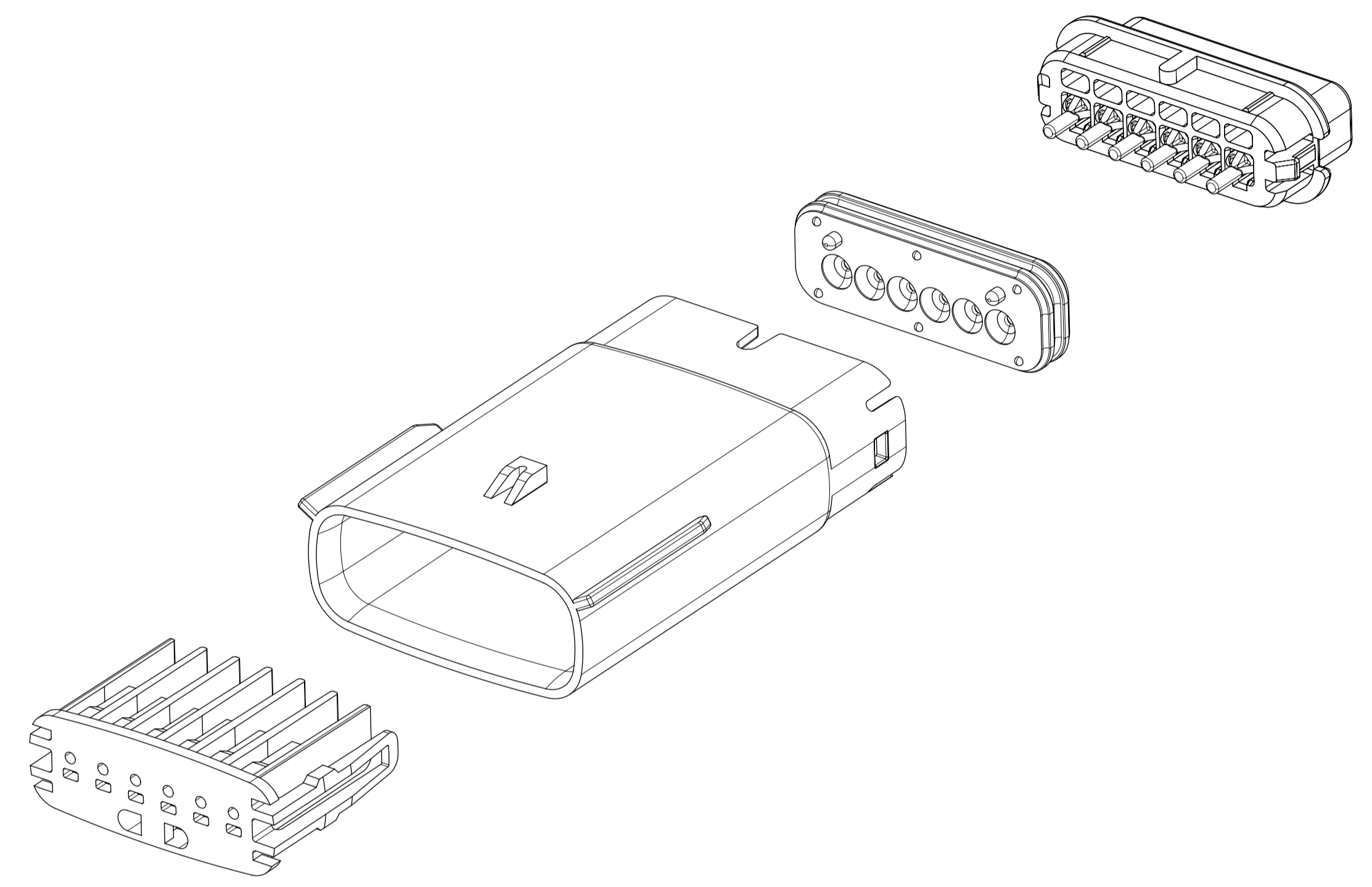

1X6

INSPECTION NUMBER LOG	
LAST NUMBER: 9	ADDED:
REMOVED:	REV
A1	NX REMASTERING , CHANGE PS DRAWING NUMBER FROM PS-160105-0001 TO PS-160074-0001 IN NOTES 1.b
A	MINOR GEOMETRY CHANGE FOR UL V0
2	UPDATED VIEWSETS
1	INITIAL RELEASE
REV	REV DESCRIPTION

<b>SYMBOLS</b> = 0 = 0 = 0 = 0 = 0 = 0 = 0 = 0 = 0	THIS DRAWING CONTAINS INFORMATION THAT IS PROPRIETARY TO MOLEX ELECTRONIC TECHNOLOGIES, LLC AND SHOULD NOT BE USED WITHOUT WRITTEN PERMISSION DIMENSION UNITS: <b>MM ONLY</b> SCALE: <b>1.5:1</b>	CURRENT REV DESC: EC NO: 602373 DRWN: DSHETTY01 2018/05/25 CHK'D: MVANSLAMBROU 2018/10/04 APPR: MVANSLAMBROU 2018/10/04 INITIAL REVISION: DRWN: APROFFITT 2015/07/21 APPR: KDEKOSKI 2016/06/14	 MX150 BLADE SINGLE ROW SEALED ASSY MAT SEAL PRODUCT CUSTOMER DRAWING	
	GENERAL TOLERANCES (UNLESS SPECIFIED) ANGULAR TOL ± 1.0° 4 PLACES ± 3 PLACES ± 2 PLACES ± 0.1 1 PLACE ± 0.2 0 PLACES ±	DRAFT WHERE APPLICABLE MUST REMAIN WITHIN DIMENSIONS THIRD ANGLE PROJECTION DRAWING: <b>A1-SIZE</b> SERIES: <b>33481</b>	DOCUMENT NUMBER: <b>SD-33481-0001</b> DOC TYPE: <b>PSD</b> DOC PART: <b>001</b> REVISION: <b>A1</b>	MATERIAL NUMBER: <b>SEE NOTE 2a.</b> CUSTOMER: <b>GENERAL MARKET</b> SHEET NUMBER: <b>1 OF 9</b>
	DOCUMENT STATUS: <b>P1</b> RELEASE DATE: <b>2018/10/04</b> 15:02:02	MOLEX ELECTRONIC TECHNOLOGIES, LLC 1300 N. GARDEN AVENUE AVONDALE, AZ 85015		
	18 17 16 15 14 13 12 11 10 9 8 7 6 5 4 3 2 1			

**SHEET DESCRIPTION**  
CONFIGURATIONS

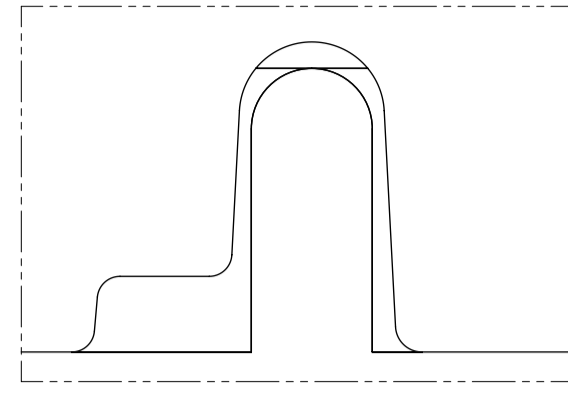

UL V0 UNIQUE FEATURE  
Partial1  
SCALE 10:1

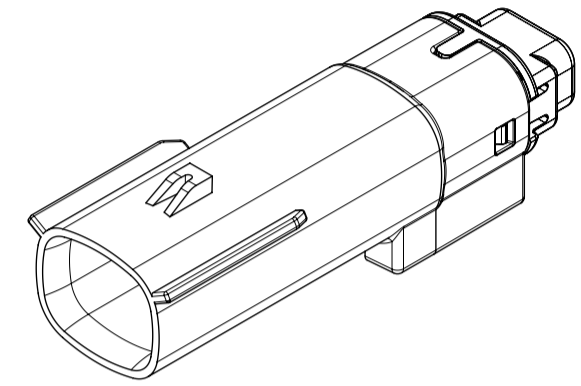

1x2 - STD

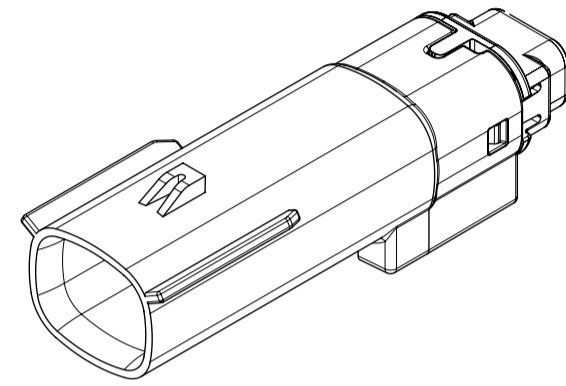

1X2 - UL V0\*

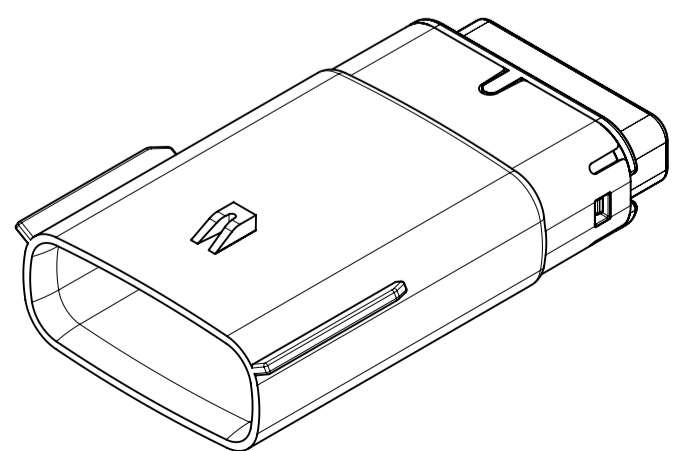

1x6 - STD

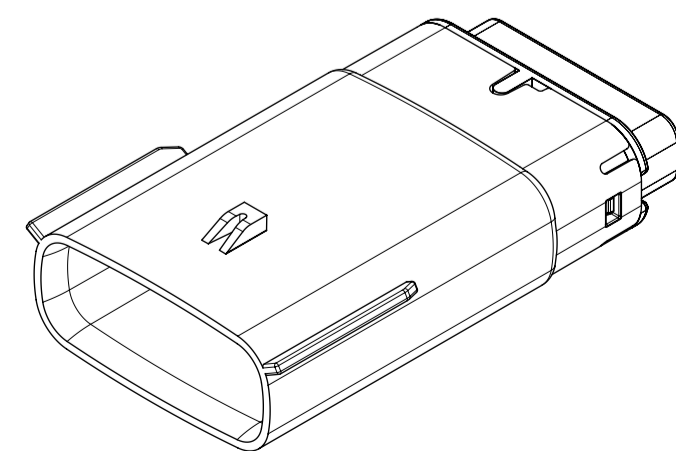

1x6 - UL V0\*

\* MINOR GEOMETRY DIFFERENCE THAN STANDARD CONFIGURATION.  
SEE NOTES 1 & 2 FOR MORE INFORMATION

SYMBOLS	THIS DRAWING CONTAINS INFORMATION THAT IS PROPRIETARY TO MOLEX ELECTRONIC TECHNOLOGIES, LLC AND SHOULD NOT BE USED WITHOUT WRITTEN PERMISSION		
	DIMENSION UNITS	SCALE	CURRENT REV DESC:
▽ = 0	MM ONLY	1.5:1	EC NO: 602373 DRWN: DSHETTY01 2018/05/25 CHK'D: MVANSLAMBROU 2018/10/04 APPR: MVANSLAMBROU 2018/10/04
▽ = 0	GENERAL TOLERANCES (UNLESS SPECIFIED)		
▽ = 0	ANGULAR TOL ± 1.0°		INITIAL REVISION: DRWN: APROFFITT 2015/07/21 APPR: KDEKOSKI 2016/06/14
▽ = 0	4 PLACES	±	
▽ = 0	3 PLACES	±	DOCUMENT NUMBER: SD-33481-0001 DOC TYPE: PSD DOC PART: 001 REVISION: A1
▽ = 0	2 PLACES	± 0.1	
▽ = 0	1 PLACE	± 0.2	MATERIAL NUMBER: SEE NOTE 2a. CUSTOMER: GENERAL MARKET SHEET NUMBER: 2 OF 9
▽ = 0	0 PLACES	±	
■ = 0	DRAFT WHERE APPLICABLE MUST REMAIN WITHIN DIMENSIONS		THIRD ANGLE PROJECTION
▽ = 0			DRAWING: A1-SIZE SERIES: 33481

**molex**

MX150 BLADE  
SINGLE ROW SEALED ASSY MAT SEAL

PRODUCT CUSTOMER DRAWING

SD-33481-0001

PSD 001 A1

SEE NOTE 2a. GENERAL MARKET

SHEET NUMBER 2 OF 9

**SHEET DESCRIPTION**  
KEY CONFIGURATIONS

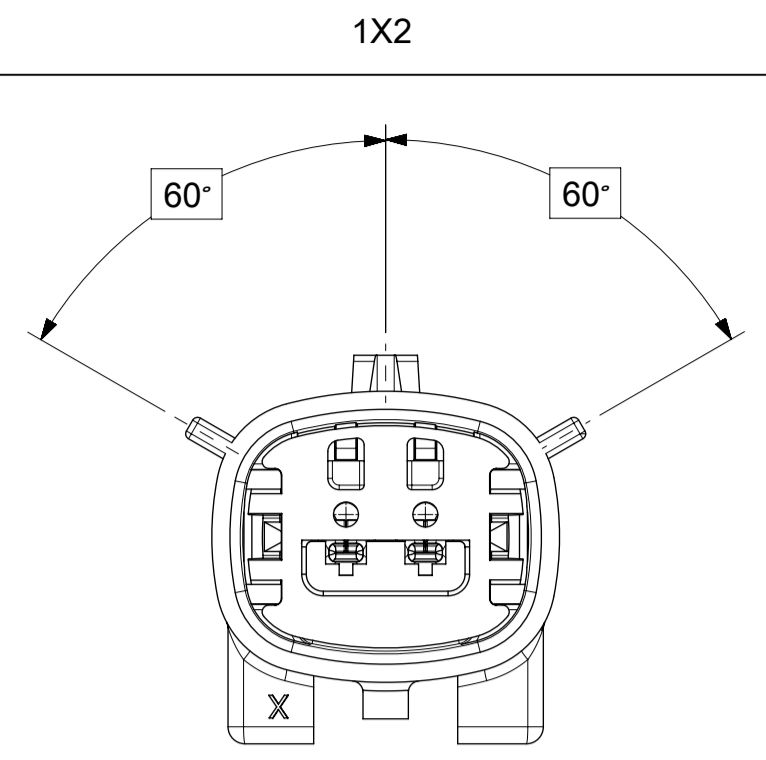

KEY A

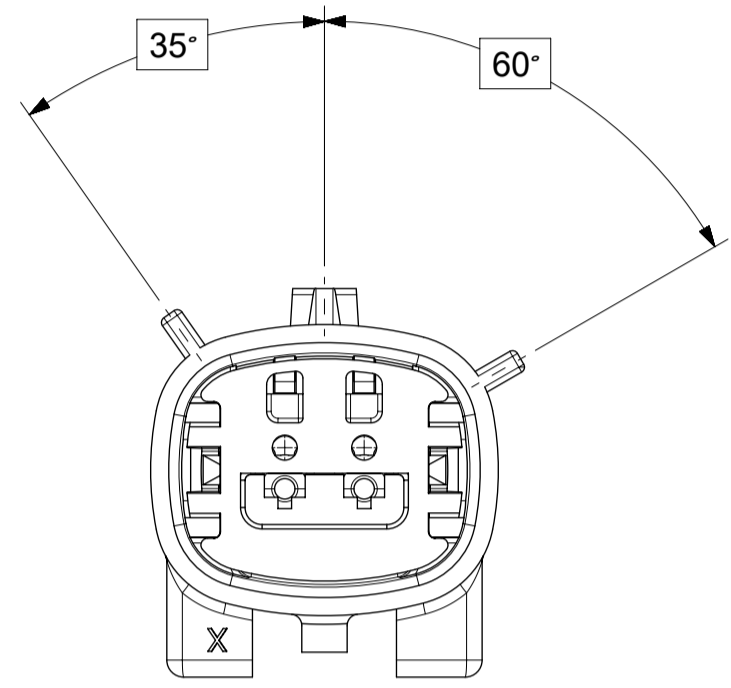

KEY B

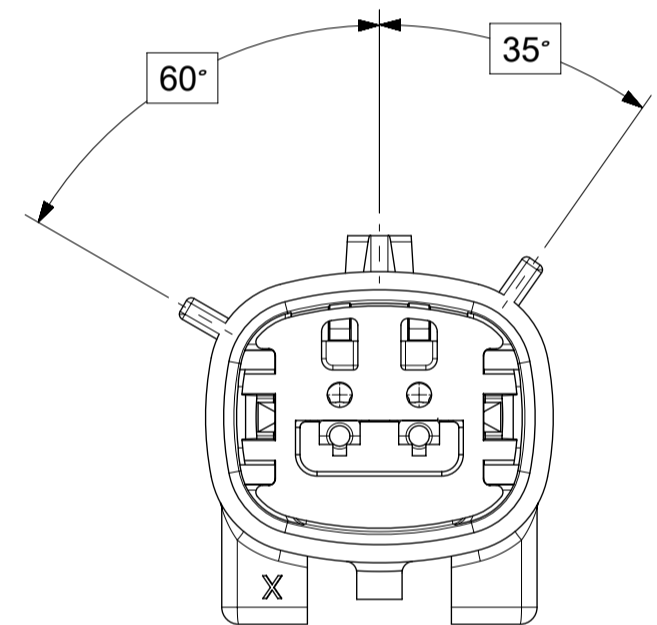

KEY C

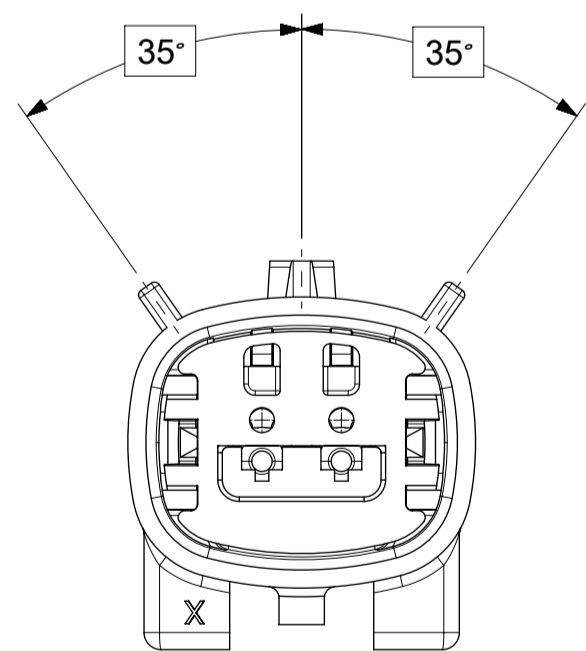

KEY D

<b>SYMBOLS</b> = 0 = 0 = 0 = 0 = 0 = 0 = 0 = 0 = 0 = 0	THIS DRAWING CONTAINS INFORMATION THAT IS PROPRIETARY TO MOLEX ELECTRONIC TECHNOLOGIES, LLC AND SHOULD NOT BE USED WITHOUT WRITTEN PERMISSION		CURRENT REV DESC:		 MX150 BLADE SINGLE ROW SEALED ASSY MAT SEAL		
	DIMENSION UNITS	SCALE	EC NO: 602373				
	MM ONLY	3:1	DRWN: DSHETTY01 2018/05/25		SD-33481-0001	PSD	001
	GENERAL TOLERANCES (UNLESS SPECIFIED)		CHK'D: MVANSLAMBROU 2018/10/04		REVISION		
	ANGULAR TOL ± 1.0°		APPR: MVANSLAMBROU 2018/10/04		A1		
	4 PLACES ±		INITIAL REVISION:		MATERIAL NUMBER		
	3 PLACES ±		DRWN: APROFFITT 2015/07/21		SEE NOTE 2a.		
	2 PLACES ± 0.1		APPR: KDEKOSKI 2016/06/14		CUSTOMER		
	1 PLACE ± 0.2		DRAWING		GENERAL MARKET		
	0 PLACES ±		SERIES		SHEET NUMBER		
DRAFT WHERE APPLICABLE MUST REMAIN WITHIN DIMENSIONS		THIRD ANGLE PROJECTION		A1-SIZE		33481	3 OF 9

**SHEET DESCRIPTION**  
KEY CONFIGURATIONS CONT.

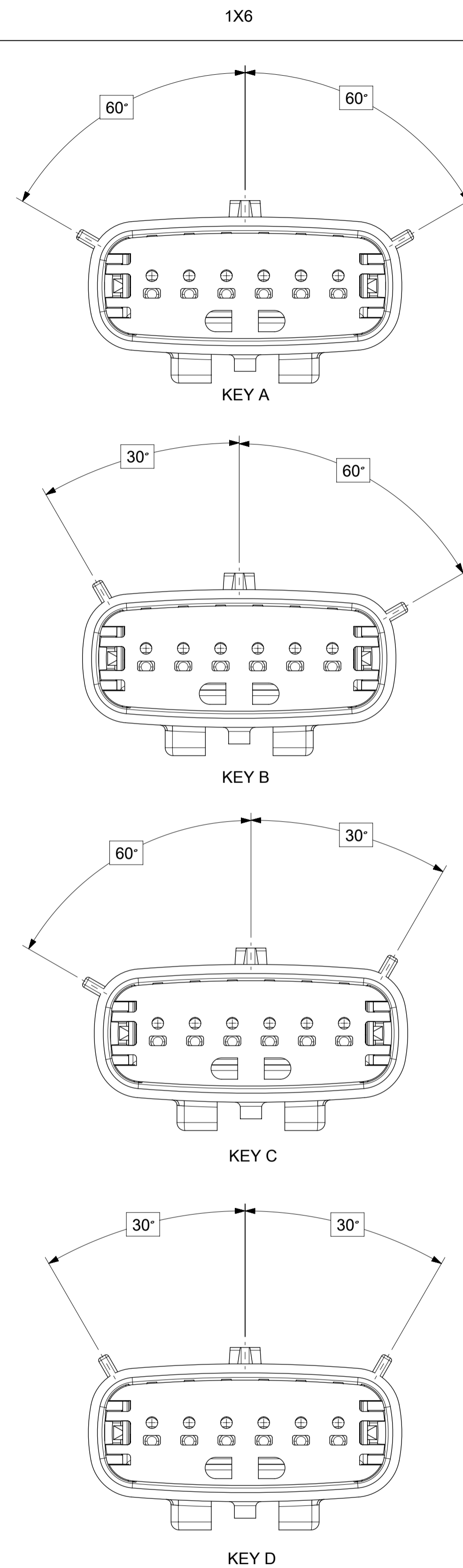



<b>SYMBOLS</b> = 0 = 0 = 0 = 0 = 0 = 0 = 0 = 0 = 0	THIS DRAWING CONTAINS INFORMATION THAT IS PROPRIETARY TO MOLEX ELECTRONIC TECHNOLOGIES, LLC AND SHOULD NOT BE USED WITHOUT WRITTEN PERMISSION DIMENSION UNITS: <b>MM ONLY</b> SCALE: <b>3:1</b>	CURRENT REV DESC: EC NO: 602373 DRWN: DSHETTY01 2018/05/25 CHK'D: MVANSLAMBROU 2018/10/04 APPR: MVANSLAMBROU 2018/10/04	 MX150 BLADE SINGLE ROW SEALED ASSY MAT SEAL		
	GENERAL TOLERANCES (UNLESS SPECIFIED) ANGULAR TOL ± 1.0° 4 PLACES ± 3 PLACES ± 2 PLACES ± 0.1 1 PLACE ± 0.2 0 PLACES ±	INITIAL REVISION: DRWN: APROFFITT 2015/07/21 APPR: KDEKOSKI 2016/06/14	PRODUCT CUSTOMER DRAWING DOCUMENT NUMBER: <b>SD-33481-0001</b> DOC TYPE: PSD DOC PART: 001 REVISION: <b>A1</b>	MATERIAL NUMBER: SEE NOTE 2a. CUSTOMER: GENERAL MARKET SHEET NUMBER: 4 OF 9	
DRAFT WHERE APPLICABLE MUST REMAIN WITHIN DIMENSIONS 	THIRD ANGLE PROJECTION 	DRAWING: <b>A1-SIZE</b> SERIES: <b>33481</b>			

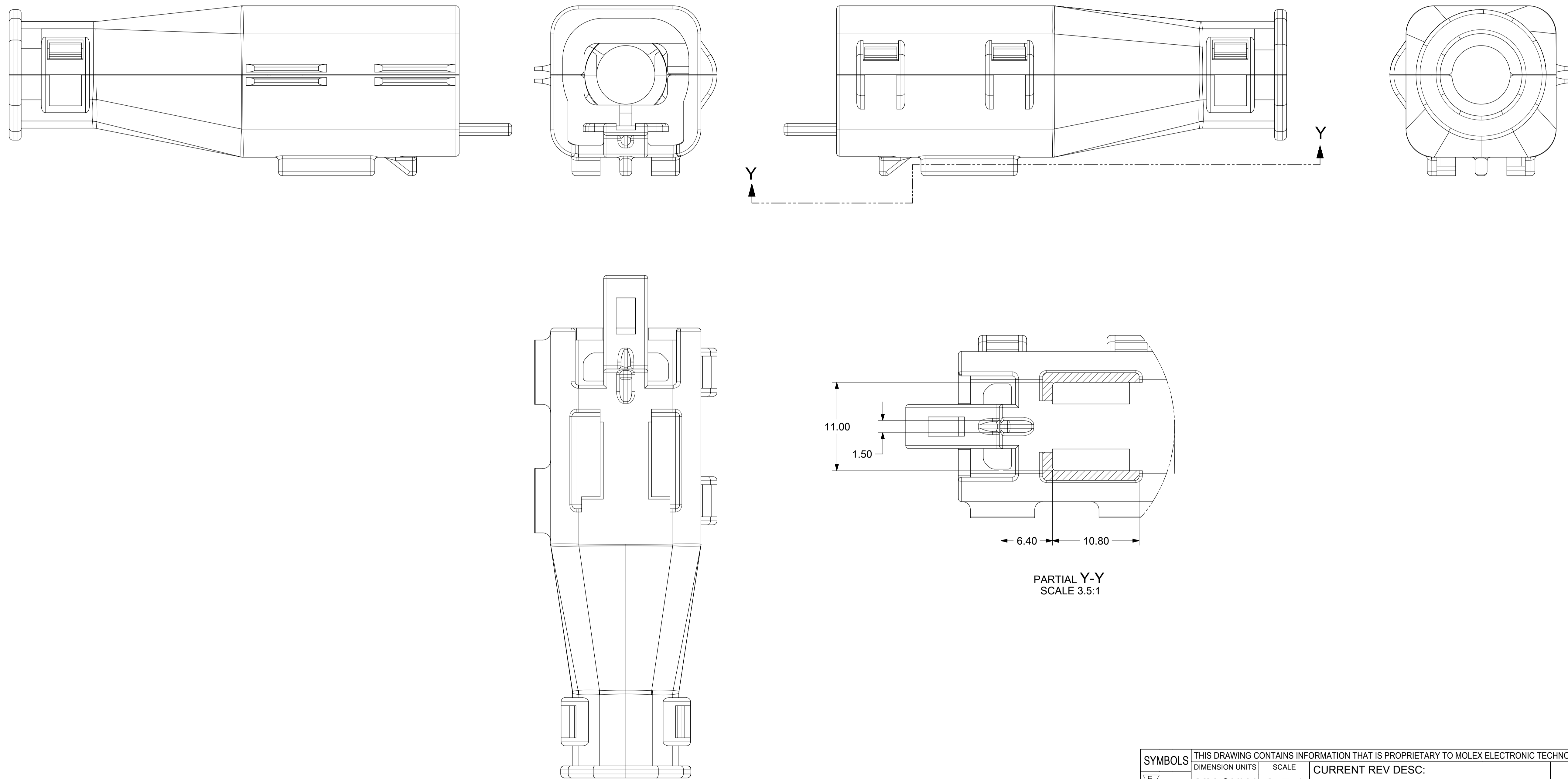

**SHEET DESCRIPTION**  
BACKSHELL

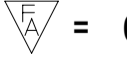
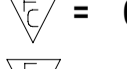
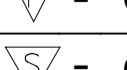
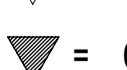
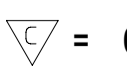
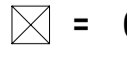

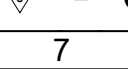
SYMBOLS		THIS DRAWING CONTAINS INFORMATION THAT IS PROPRIETARY TO MOLEX ELECTRONIC TECHNOLOGIES, LLC AND SHOULD NOT BE USED WITHOUT WRITTEN PERMISSION		CURRENT REV DESC:			 MX150 BLADE SINGLE ROW SEALED ASSY MAT SEAL		
DIMENSION UNITS	SCALE			EC NO:	DRWN:	DATE			
 = 0	MM ONLY	3.5:1		602373	DSHETTY01	2018/05/25			
 = 0	GENERAL TOLERANCES (UNLESS SPECIFIED)			CHK'D:	MVANSLAMBROU	2018/10/04			
 = 0	ANGULAR TOL ± 1.0°			APPR:	MVANSLAMBROU	2018/10/04			
 = 0	4 PLACES ±			INITIAL REVISION:					
 = 0	3 PLACES ±			DRWN:	APROFFITT	2015/07/21			
 = 0	2 PLACES ± 0.1			APPR:	KDEKOSKI	2016/06/14			
 = 0	1 PLACE ± 0.2			THIRD ANGLE PROJECTION					
 = 0	0 PLACES ±			DRAWING	A1-SIZE	SERIES	33481		
= 0	DRAFT WHERE APPLICABLE MUST REMAIN WITHIN DIMENSIONS			MATERIAL NUMBER	SEE NOTE 2a.	CUSTOMER	GENERAL MARKET	SHEET NUMBER	8 OF 9

PRODUCT CUSTOMER DRAWING		
DOCUMENT NUMBER	DOC TYPE	DOC PART
SD-33481-0001	PSD	001
		REVISION
		A1

**SHEET DESCRIPTION**  
BACKSHELL CONFIGURATIONS

CKT	BLADE CONFIGURATION	RECEPTACLE CONFIGURATION	DIMENSIONS				
			M	N	P	R	S
1X2	STANDARD	STANDARD	107.84	29.50	27.00	26.25	25.00

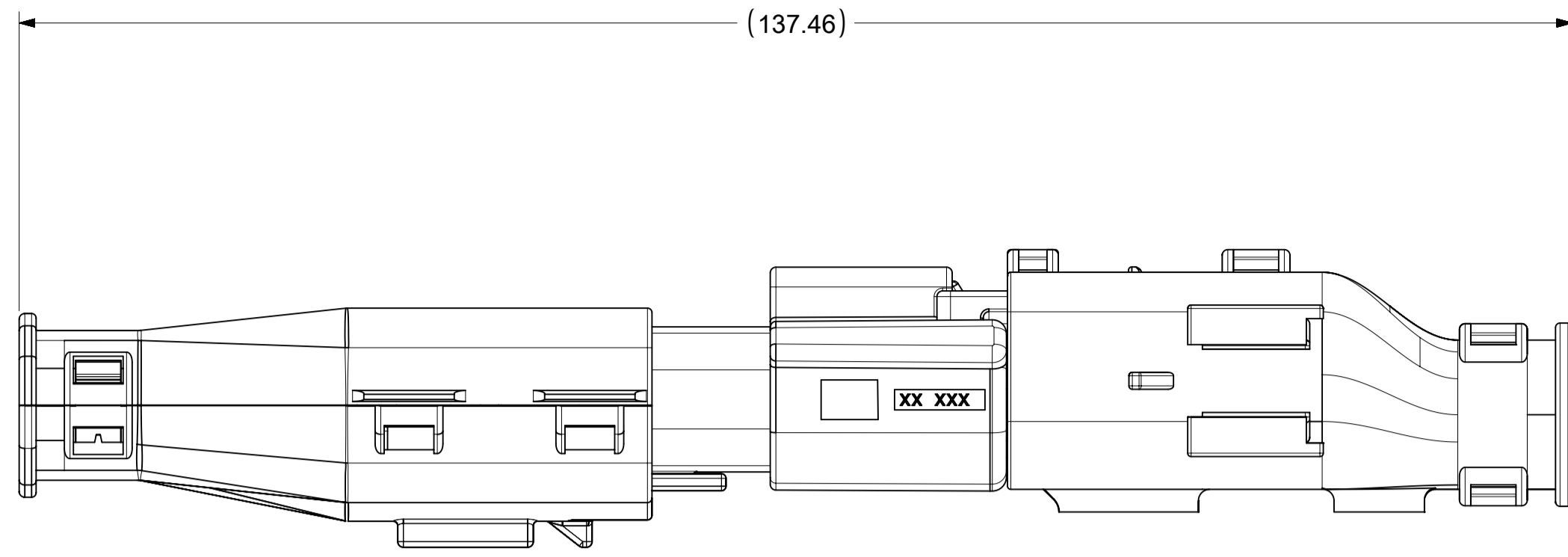

OVERALL MATED SYSTEM WITH BLADE AND RECEPTACLE BACKSHELL

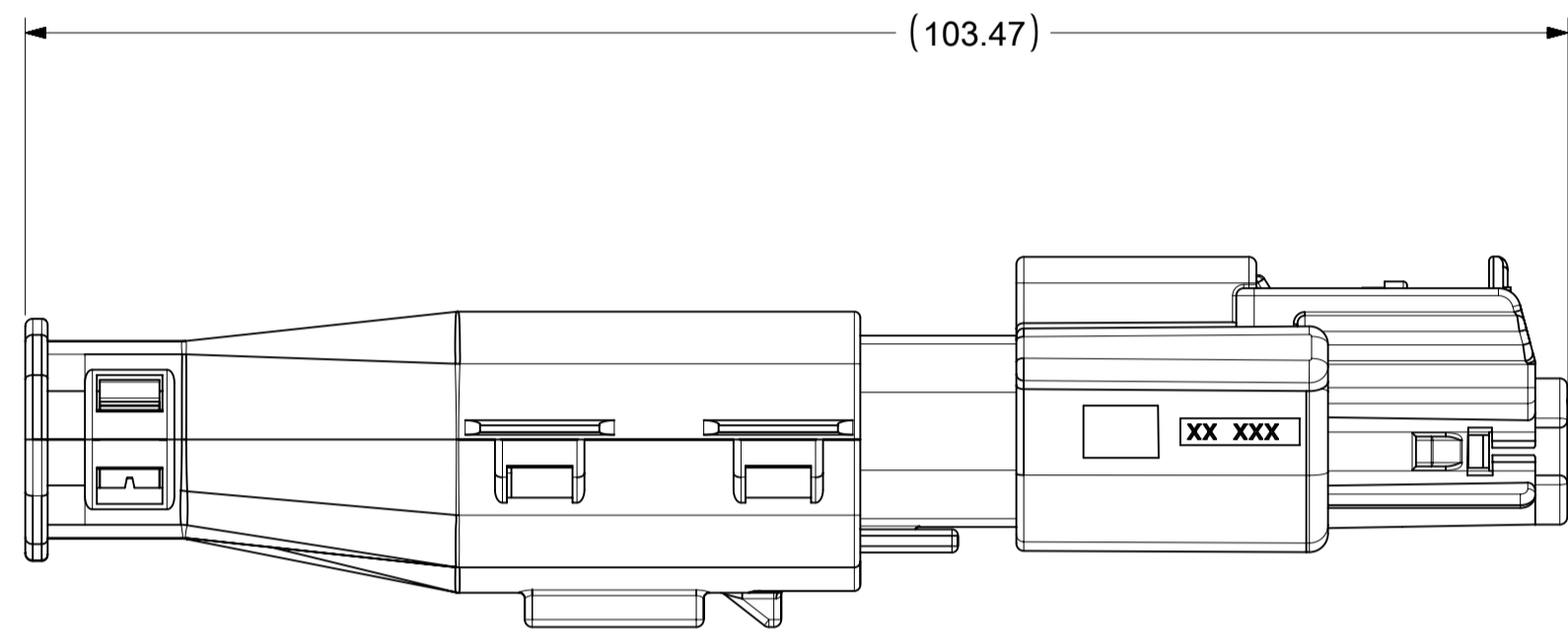
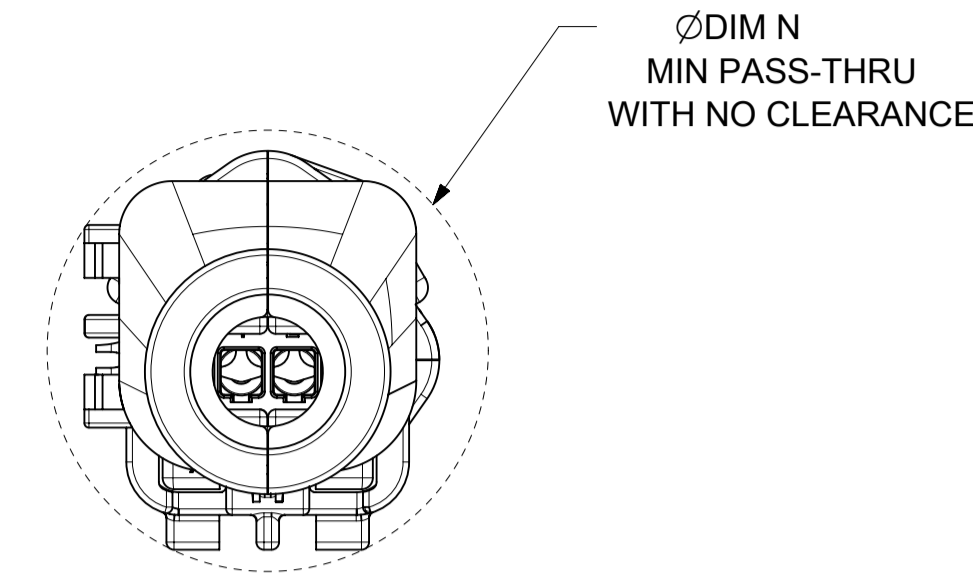

OVERALL MATED SYSTEM WITH BLADE BACKSHELL

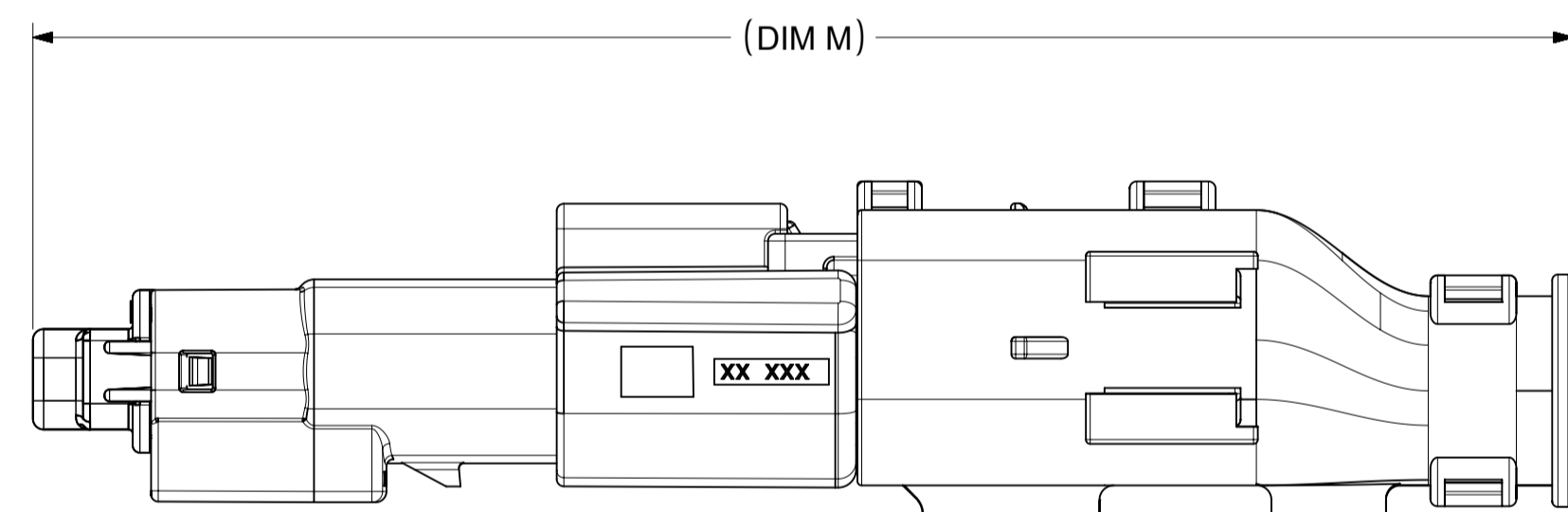
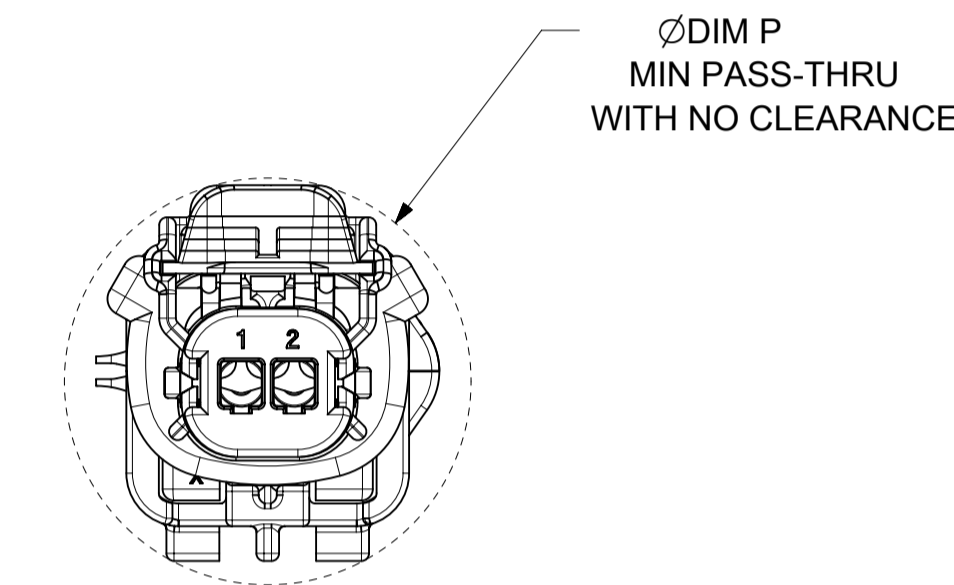

OVERALL MATED SYSTEM WITH RECEPTACLE BACKSHELL

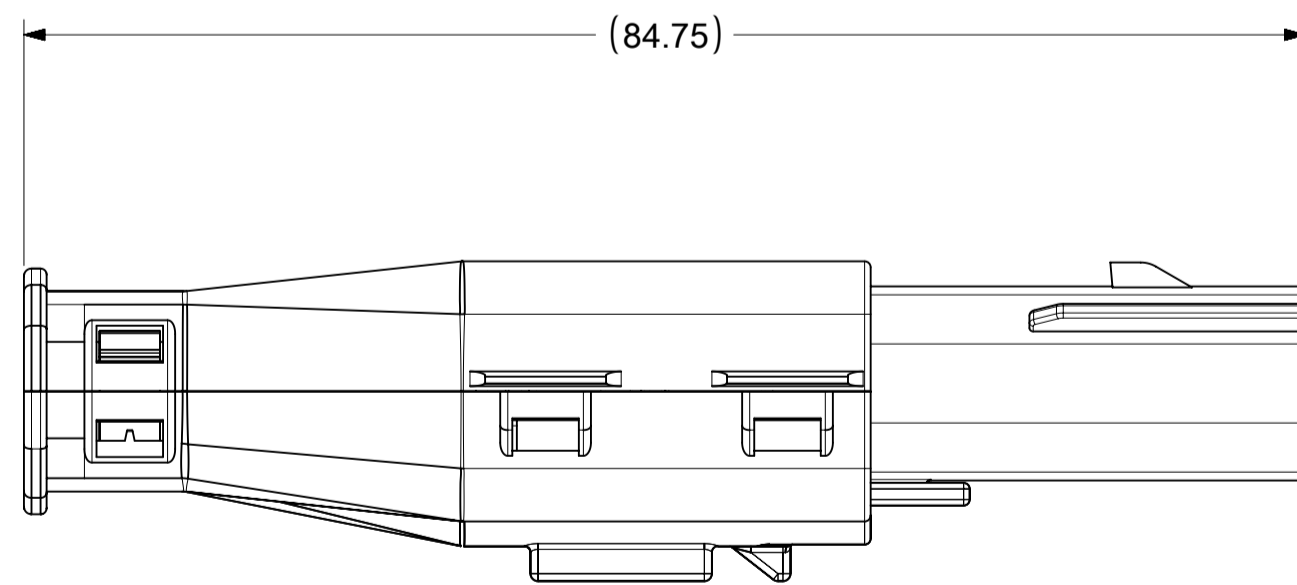
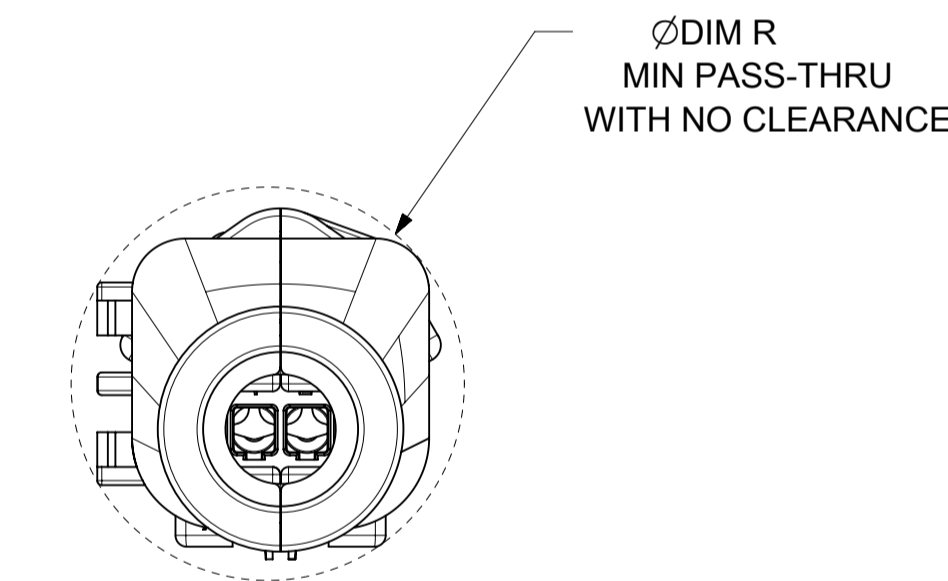

BLADE SEALED ASSEMBLY WITH BLADE BACKSHELL

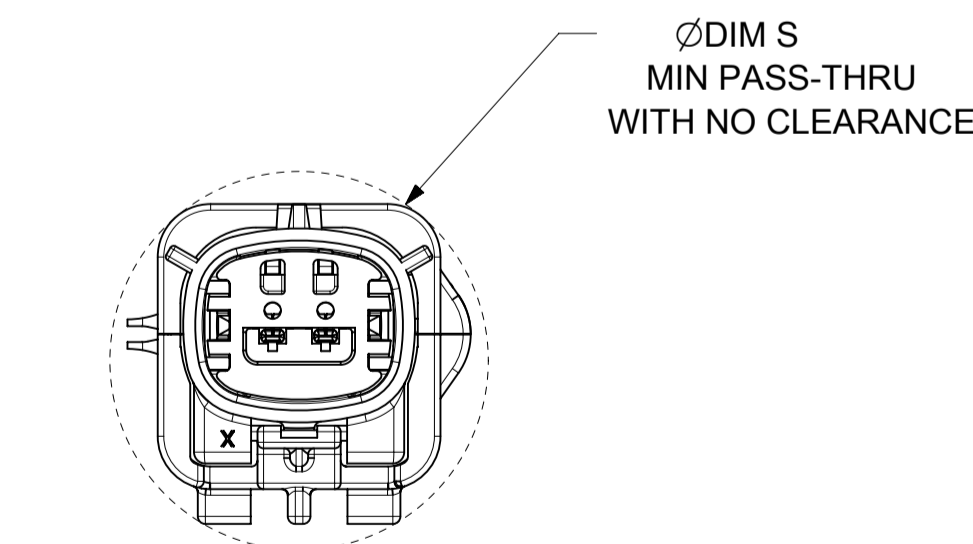

<b>SYMBOLS</b> = 0 = 0 = 0 = 0 = 0 = 0 = 0 = 0 = 0 = 0	THIS DRAWING CONTAINS INFORMATION THAT IS PROPRIETARY TO MOLEX ELECTRONIC TECHNOLOGIES, LLC AND SHOULD NOT BE USED WITHOUT WRITTEN PERMISSION DIMENSION UNITS: <b>MM ONLY</b> SCALE: <b>2:1</b>	CURRENT REV DESC:  EC NO: 602373 DRWN: DSHETTY01 2018/05/25 CHK'D: MVANSLAMBROU 2018/10/04 APPR: MVANSLAMBROU 2018/10/04	  MX150 BLADE SINGLE ROW SEALED ASSY MAT SEAL
	GENERAL TOLERANCES (UNLESS SPECIFIED) ANGULAR TOL ± 1.0° 4 PLACES ± 3 PLACES ± 2 PLACES ± 0.1 1 PLACE ± 0.2 0 PLACES ±	INITIAL REVISION: DRWN: APROFFITT 2015/07/21 APPR: KDEKOSKI 2016/06/14	
DRAFT WHERE APPLICABLE MUST REMAIN WITHIN DIMENSIONS	THIRD ANGLE PROJECTION	DRAWING: <b>A1-SIZE</b> SERIES: <b>33481</b>	MATERIAL NUMBER: SEE NOTE 2a. CUSTOMER: GENERAL MARKET SHEET NUMBER: 9 OF 9

TABLE OF CONTENTS	
SHEET NO.	SHEET DESCRIPTION
1	NOTES
2	KEY CONFIGURATIONS
3	BLADE SEALED ASSEMBLY
4	SYSTEM PACKAGING
5	BOM

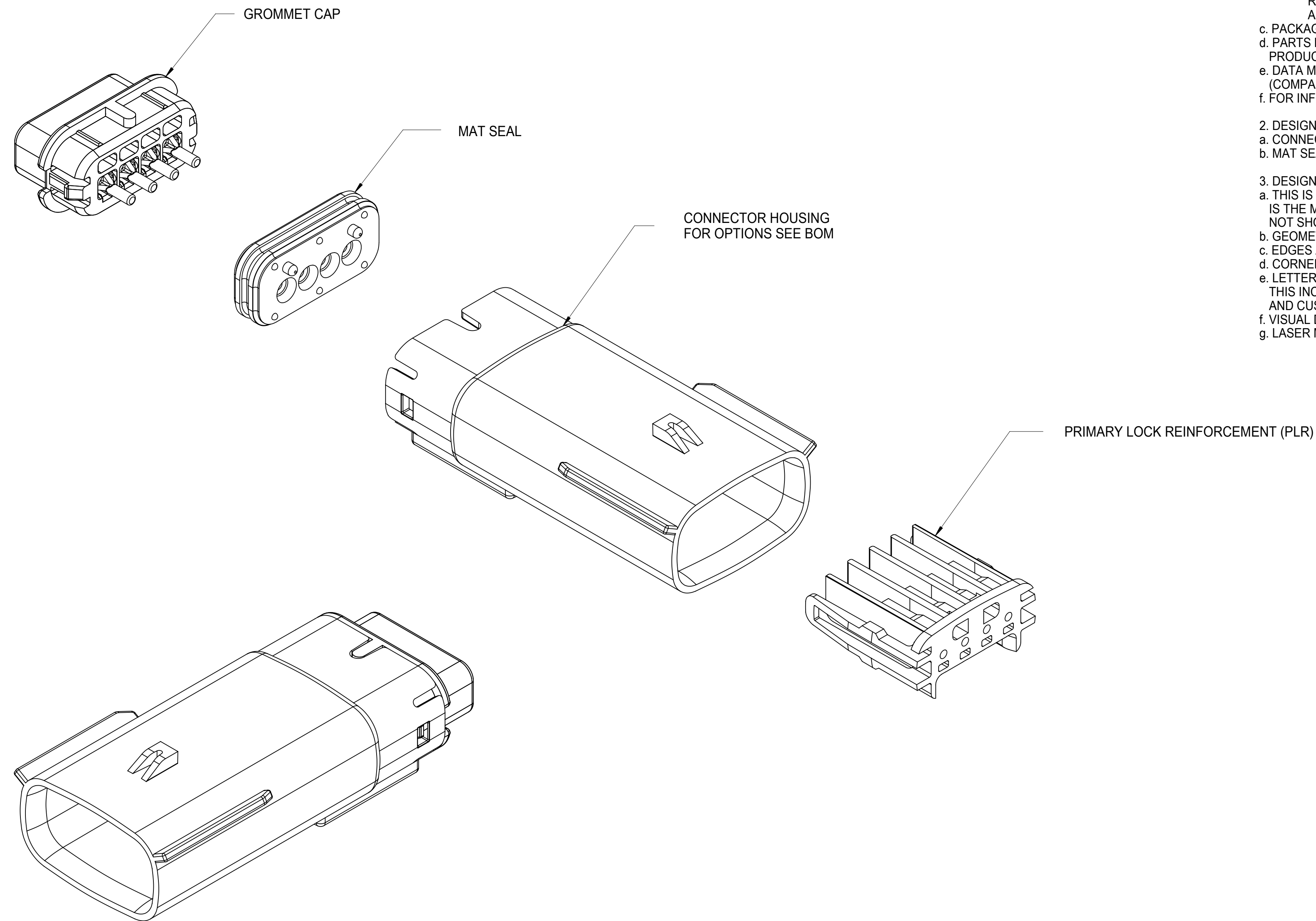

NOTES: VALID UNLESS OTHERWISE SPECIFIED

1. GENERAL:
  - a. APPLICATION SPECIFICATION SEE: AS-33472-100  
CONTAINS: PRODUCT INTRODUCTION, PRODUCT SUMMARY, CONNECTOR ASSEMBLY, PACKAGING INFORMATION, CONNECTOR MATING, SERVICE INSTRUCTIONS, ELECTRICAL CONTINUITY CHECKING, CRIMPING, AND TROUBLESHOOTING.  
-DESIGNED TO MATE WITH RECEPTACLE SEALED ASSEMBLY SPECIFIED IN MOLEX DRAWING SD-33471-041.  
-FOR 1.5mm BLADE TERMINALS TO BE USED WITH THIS ASSEMBLY SEE MOLEX DRAWING SD-33000-001.  
-SYSTEM TO BE USED WITH WIRE WITHIN DIAMETER RANGE OF 1.2mm TO 2.69mm.  
-ASSEMBLY SHIPPED WITH PLR IN PRE-LOCK POSITION  
-IN THE EVENT THAT THE PLR IS FOUND IN THE SEATED (FINAL LOCK) POSITION, REFER TO MOLEX SPECIFICATION PS-34646-001, AVAILABLE AT [www.molex.com](http://www.molex.com) <<http://www.molex.com>>  
-ASSEMBLY CONFORMS TO SAE/USCAR-2 REV.4 WITH THE FOLLOWING EXCEPTIONS:  
TERMINAL INSERTION FORCE FOR WIRE DIAMETER ABOVE 2.5mm NOT EXCEEDING 2.69mm SHALL NOT EXCEED 45 NEWTONS.
  - b. PRODUCT SPECIFICATION SEE: PS-33471-000  
CONTAINS: PRODUCT INTRODUCTION, PRODUCT SUMMARY, RATINGS (CURRENT, TEMPERATURE, SEALING, AND FLAMMABILITY), AND PRODUCT VALIDATION.
  - c. PACKAGING SPECIFICATION PER MOLEX DRAWING: PK-31300-635
  - d. PARTS MUST BE IN COMPLIANCE TO MOLEX CHEMICAL SUBSTANCES FOR PRODUCTS AND PACKAGING SPECIFICATION: ES-40000-5016
  - e. DATA MUST BE SUBMITTED UNDER THE MOLEX PART NUMBER TO IMDS (COMPANY ID#13255)
  - f. FOR INFORMATION ON 1X4 BLADE SEALED ASSEMBLY WITH SHORTING BAR SEE SD-31280-200.
2. DESIGN - MATERIALS:
  - a. CONNECTOR HOUSING, GROMMET CAP, PLR: SPS/NYLON BLEND 20% GLASS FILLED
  - b. MAT SEAL: INHERENTLY LUBRICATED SILICONE
3. DESIGN - GEOMETRY:
  - a. THIS IS A 100% CAD GENERATED PART. THE CAD MATHEMATICAL DATA IS THE MASTER FOR THIS PART. FOR DIMENSIONAL OR ANY INFORMATION NOT SHOWN ON THIS DRAWING, ANALYZE THE CAD MODEL.
  - b. GEOMETRIC DIMENSIONS AND TOLERANCES PER ASME Y14.5M - 1994
  - c. EDGES AND UNDIMENSIONED DETAILS PER ISO13715
  - d. CORNERS SHOWN AS SHARP TO BE R 0.2 MAX.
  - e. LETTERING SHALL BE 0.15 MAX RAISED IN 0.25 MAX RECESS PAD. THIS INCLUDES RECYCLING CODE, CAVITY ID, VENDOR IDENTIFICATION, AND CUSTOMER MATERIAL NUMBER.
  - f. VISUAL DEFECTS SHALL MEET COSMETIC STANDARD PS-45499-002 (Class B)
  - g. LASER MARKING: TBD

SYMBOLS	THIS DRAWING CONTAINS INFORMATION THAT IS PROPRIETARY TO MOLEX ELECTRONIC TECHNOLOGIES, LLC AND SHOULD NOT BE USED WITHOUT WRITTEN PERMISSION		CURRENT REV DESC:		<b>molex</b>	
	DIMENSION UNITS	SCALE				
▽ = 0	mm	3:1			MX150 1X4 BLADE SEALED ASSEMBLY MAT SEAL	
▽ = 0	GENERAL TOLERANCES (UNLESS SPECIFIED)					
▽ = 0	ANGULAR TOL ± 3.0°		EC NO: 607930		PRODUCT CUSTOMER DRAWING	
▽ = 0	4 PLACES	±	DRWN: HKLIANG 2018/11/09			
▽ = 0	3 PLACES	±	CHK'D: JDENG02 2018/12/04		DOCUMENT NUMBER	
▽ = 0	2 PLACES	± 0.1	APPR: JDENG02 2018/12/04			
▽ = 0	1 PLACE	± 0.3	INITIAL REVISION:		DOC TYPE	
▽ = 0	0 PLACES	±	DRWN: DGRIFITHS 2005/08/26			
▽ = 0	DRAFT WHERE APPLICABLE MUST REMAIN WITHIN DIMENSIONS		APPR: smarceau 2005/08/29		DOC PART	
▽ = 0	THIRD ANGLE PROJECTION		DRAWING			
▽ = 0	D-DRAWING		SERIES		REVISION	
▽ = 0	D-SIZE		33481			
			MATERIAL NUMBER		CUSTOMER	
			GENERAL MARKET			
					1 OF 5	



KEY CONFIGURATIONS

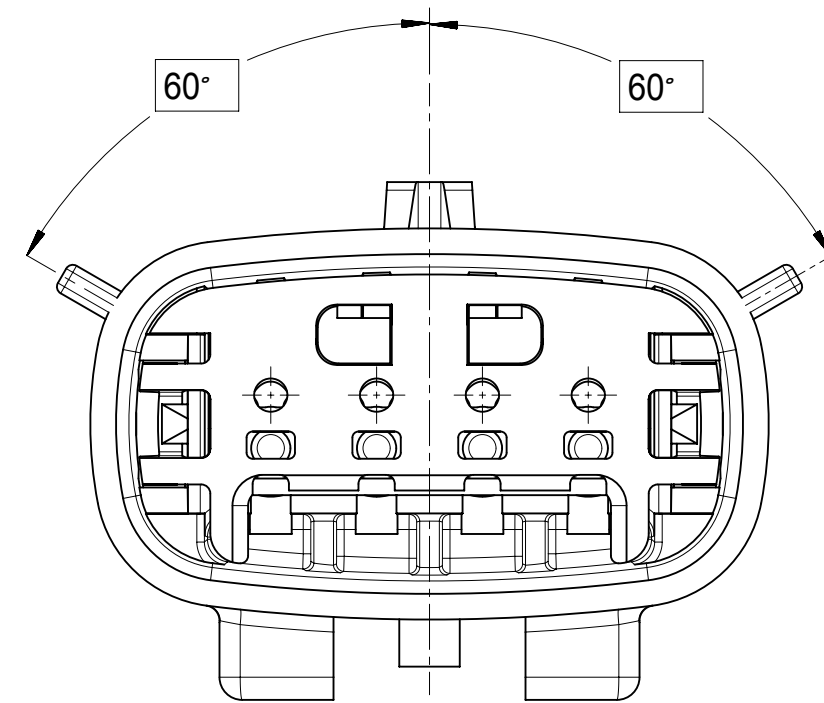

KEY A

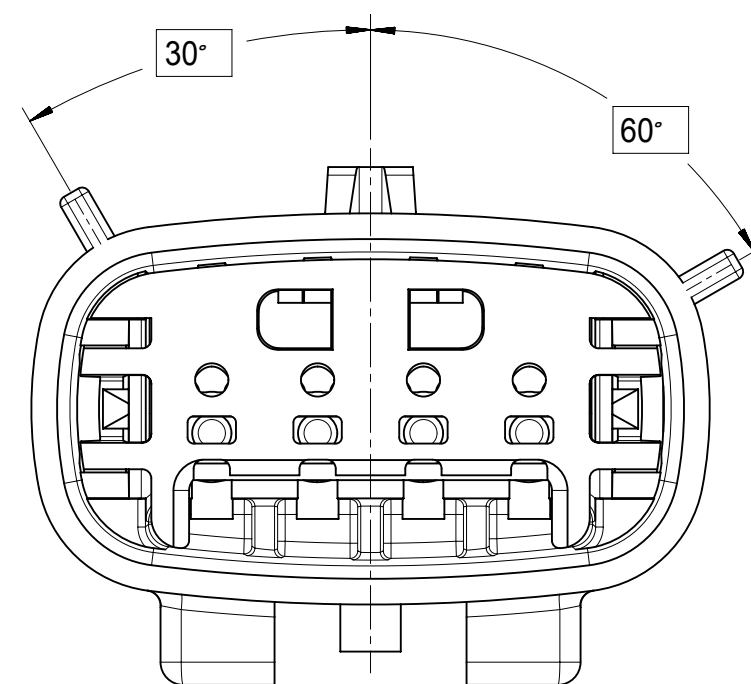

KEY B

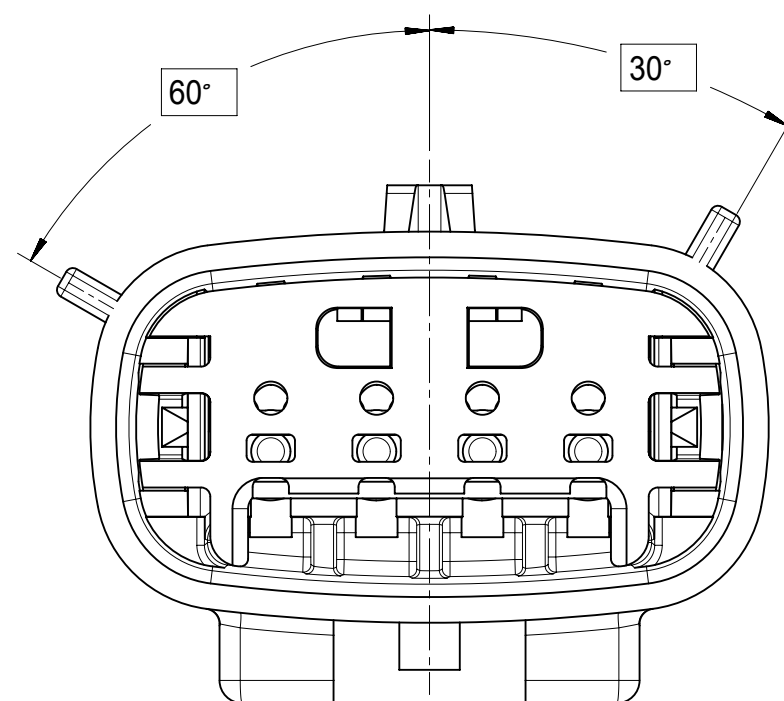

KEY C

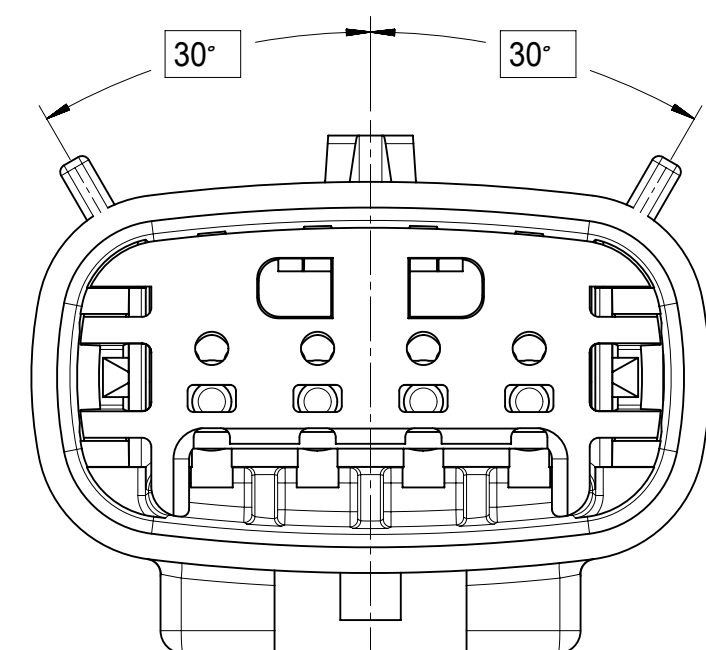

KEY D

SYMBOLS	THIS DRAWING CONTAINS INFORMATION THAT IS PROPRIETARY TO MOLEX ELECTRONIC TECHNOLOGIES, LLC AND SHOULD NOT BE USED WITHOUT WRITTEN PERMISSION		
	DIMENSION UNITS	SCALE	CURRENT REV DESC:
▽ = 0	mm	4:1	EC NO: 607930 DRWN: HKLIANG 2018/11/09 CHK'D: JDENG02 2018/12/04 APPR: JDENG02 2018/12/04
▽ = 0	GENERAL TOLERANCES (UNLESS SPECIFIED)		
▽ = 0	ANGULAR TOL ± 3.0°		INITIAL REVISION: DRWN: DGRIFITHS 2005/08/26 APPR: smarceau 2005/08/29
▽ = 0	4 PLACES	±	
▽ = 0	3 PLACES	±	DOCUMENT NUMBER: SD-33481-041   DOC TYPE: PSD   DOC PART: 001   REVISION: W2
▽ = 0	2 PLACES	± 0.1	
▽ = 0	1 PLACE	± 0.3	MATERIAL NUMBER: GENERAL MARKET   CUSTOMER:   SHEET NUMBER: 2 OF 5
▽ = 0	0 PLACES	±	
▽ = 0	DRAFT WHERE APPLICABLE MUST REMAIN WITHIN DIMENSIONS		THIRD ANGLE PROJECTION
▽ = 0			DRAWING: D-SIZE   SERIES: 33481

**molex**

MX150 1X4 BLADE  
SEALED ASSEMBLY MAT SEAL

PRODUCT CUSTOMER DRAWING

DOCUMENT NUMBER: SD-33481-041 | DOC TYPE: PSD | DOC PART: 001 | REVISION: W2

MATERIAL NUMBER: GENERAL MARKET | CUSTOMER: | SHEET NUMBER: 2 OF 5

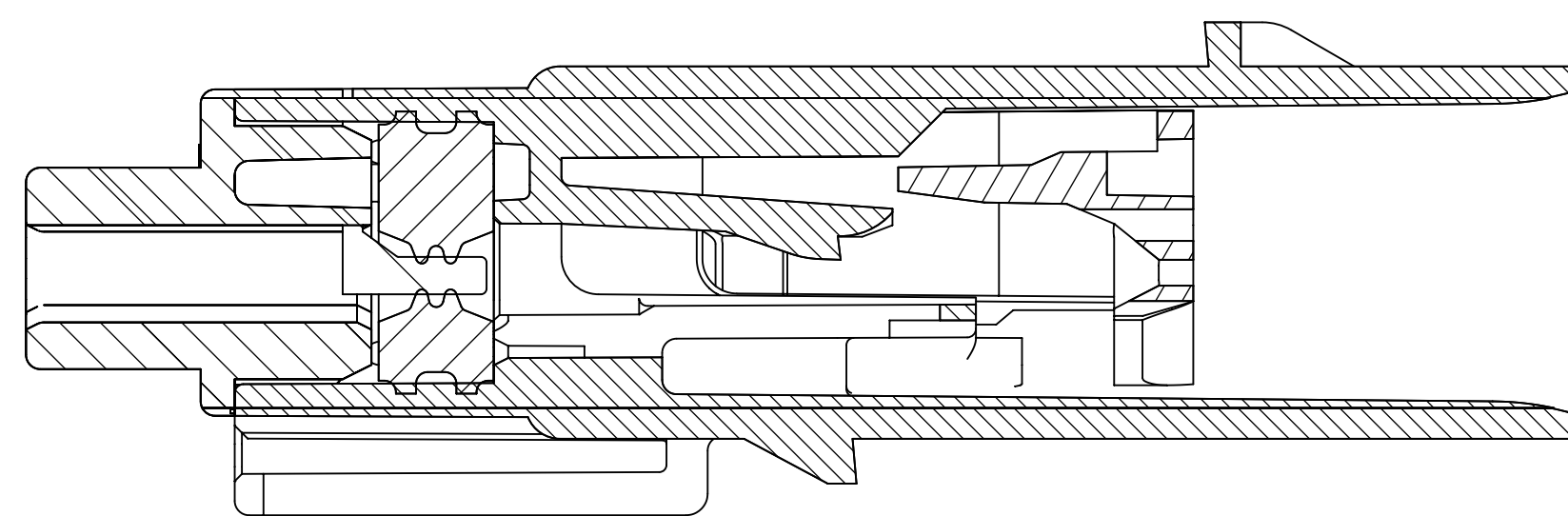
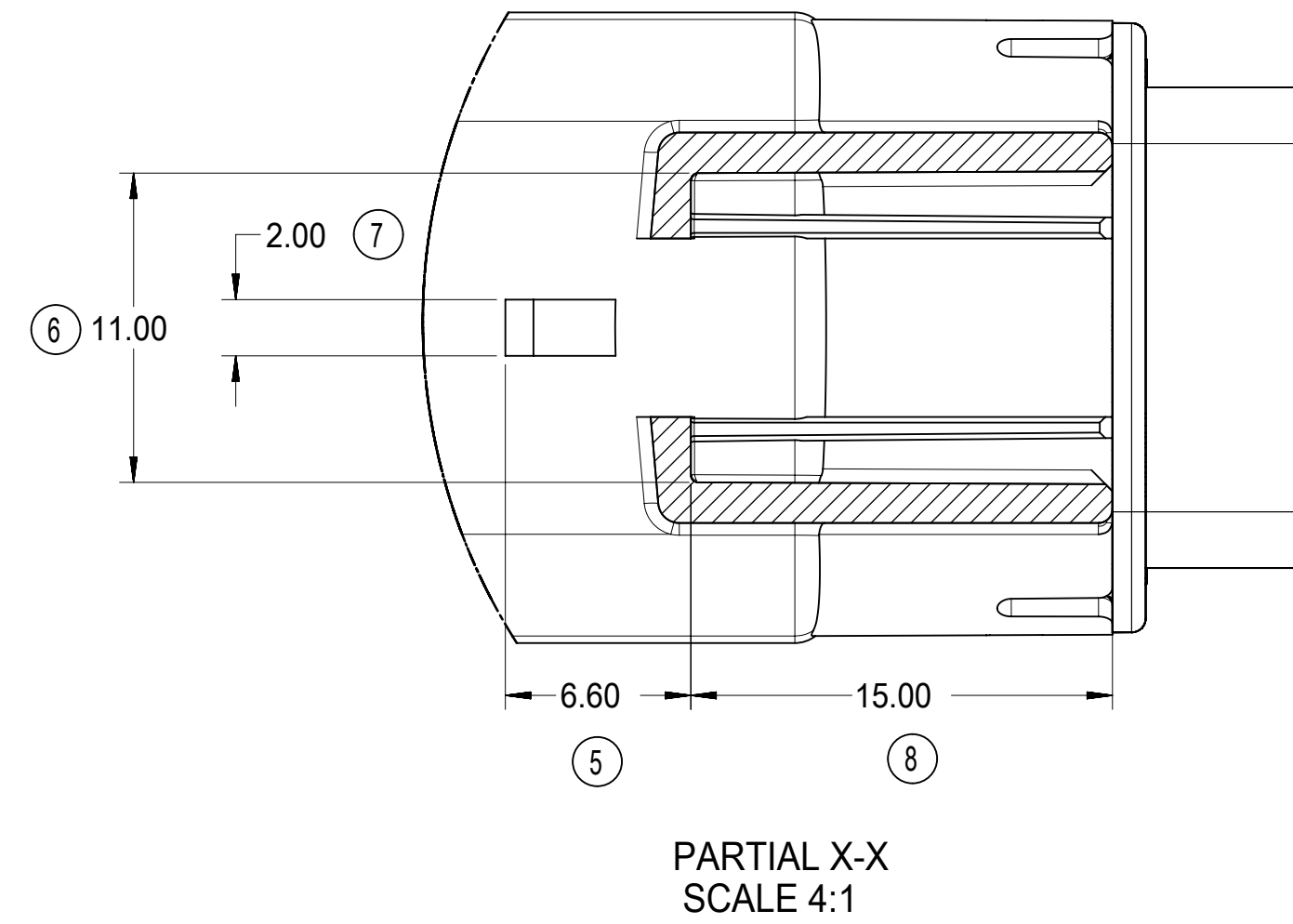
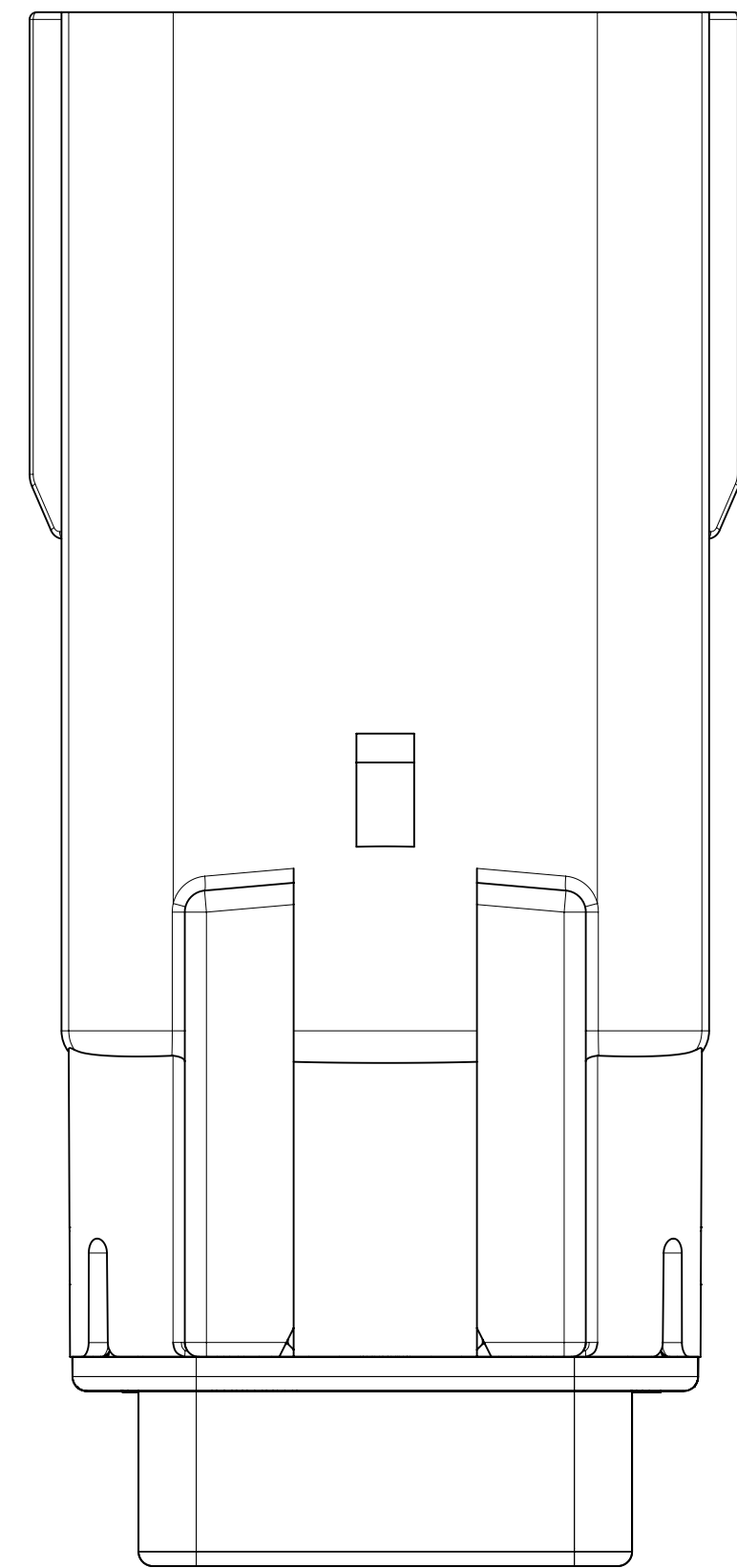
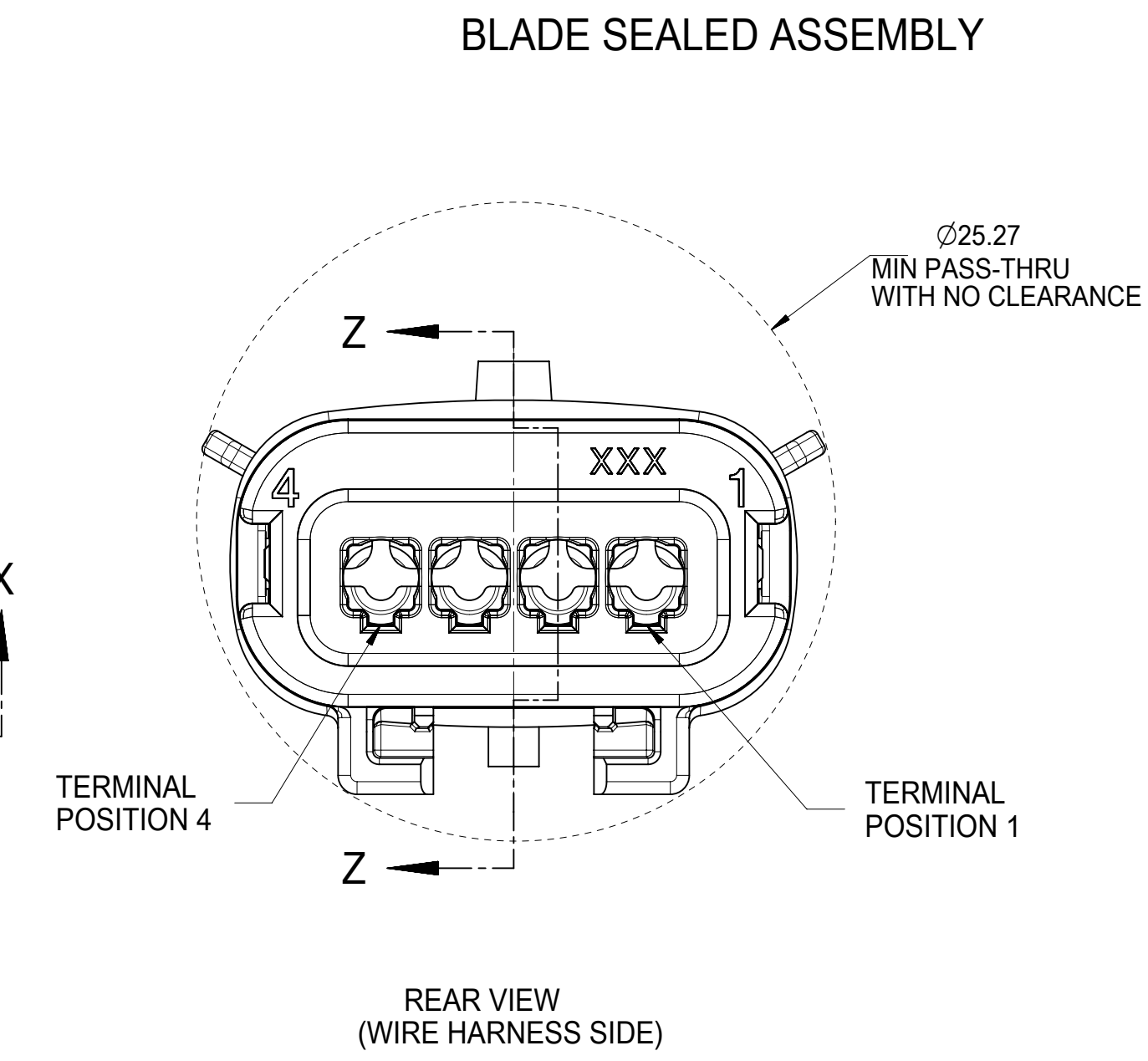
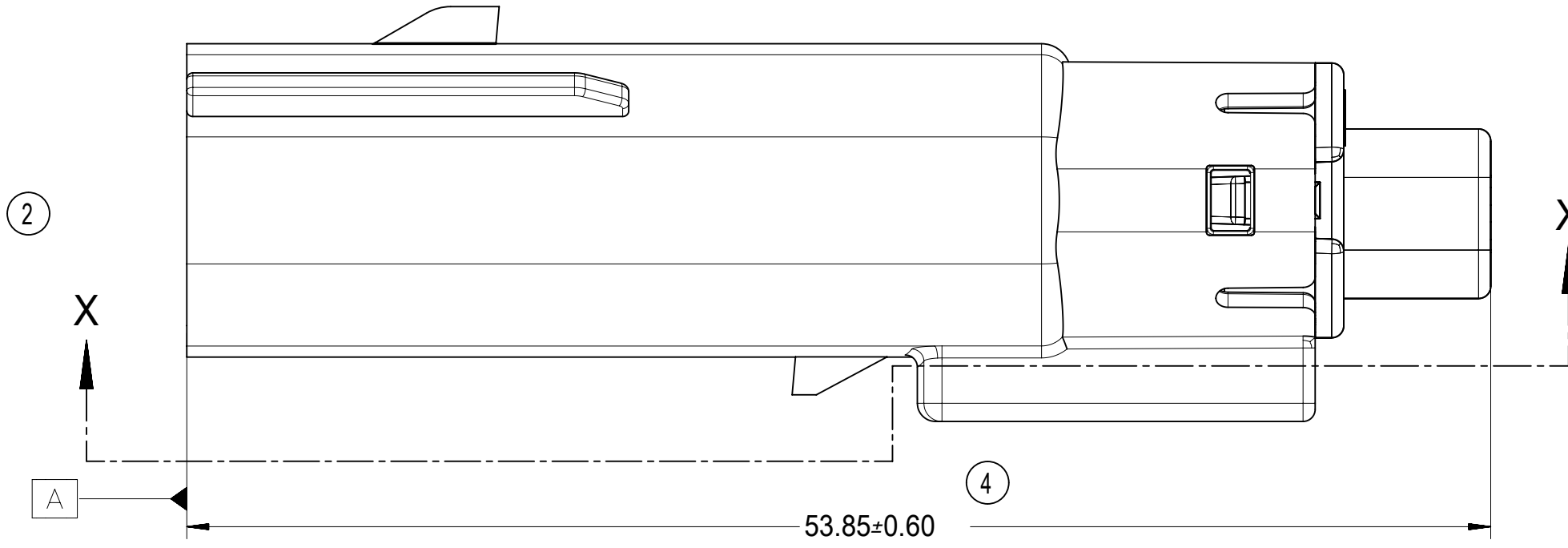
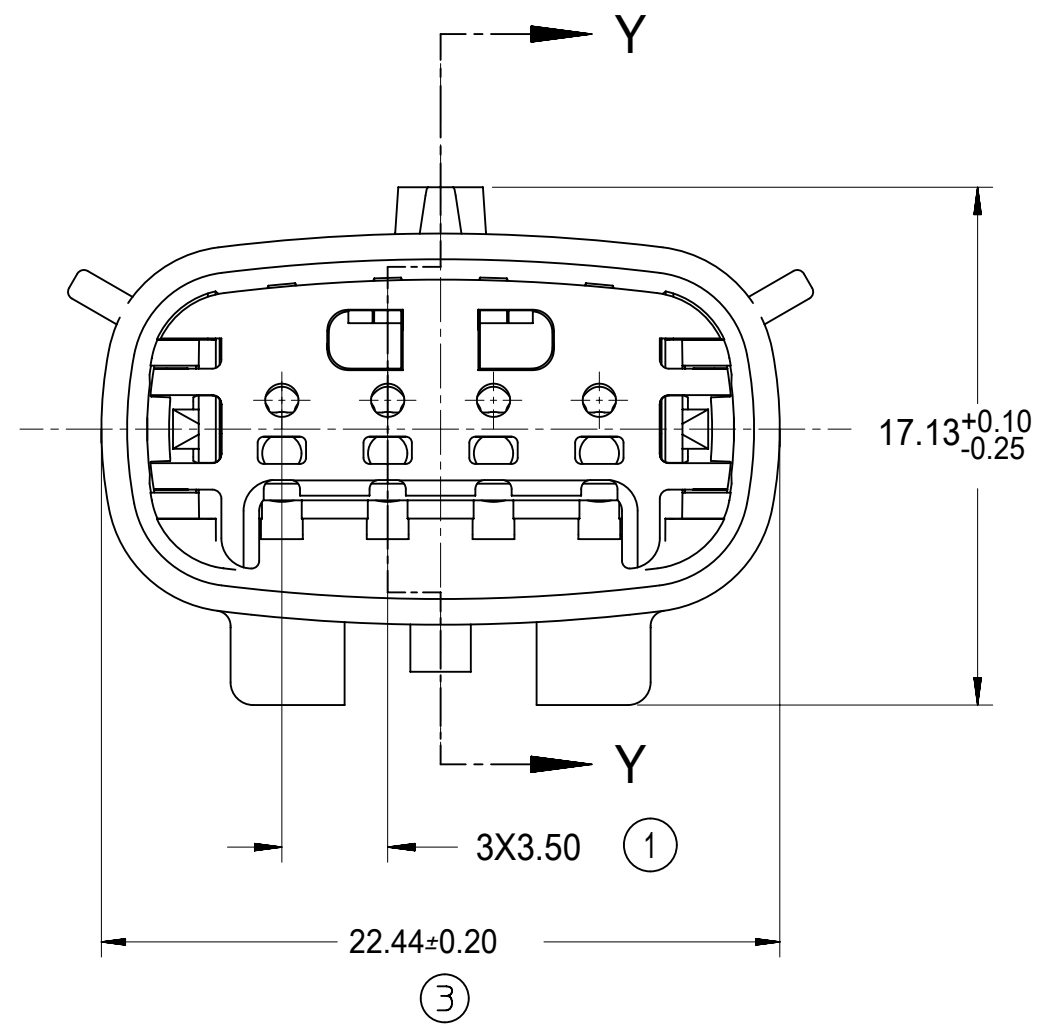
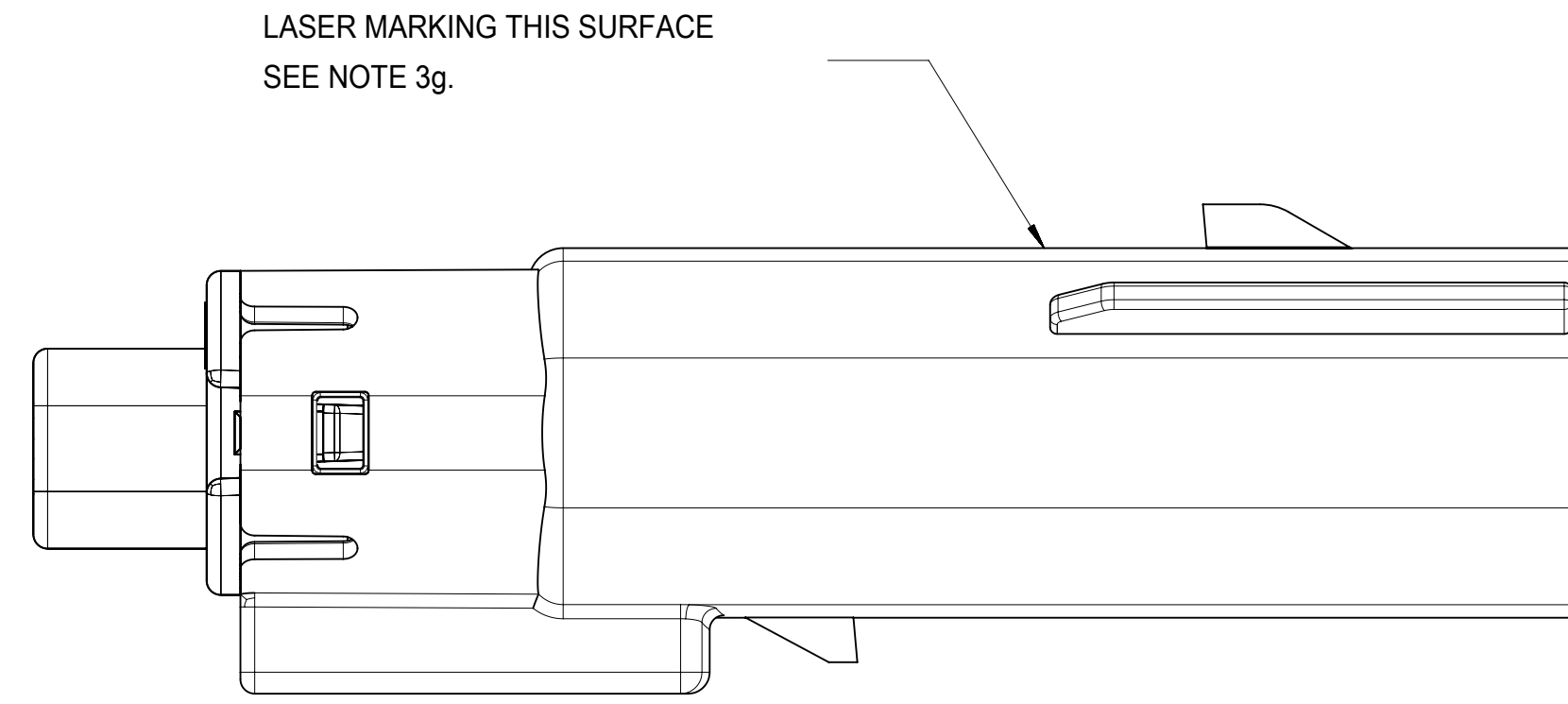

PRIMARY LOCK REINFORCEMENT (PLR) SHOWN IN PRE-STAGED POSITION

SECTION Z-Z

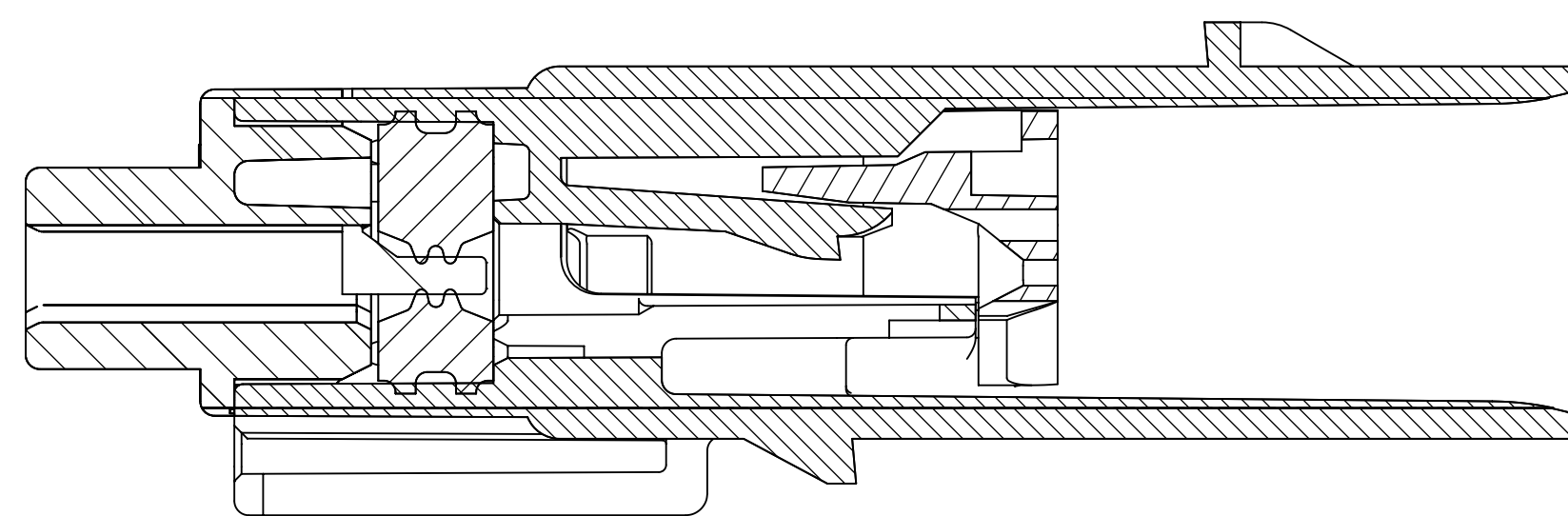

PRIMARY LOCK REINFORCEMENT (PLR) SHOWN IN FINAL-LOCK POSITION

SECTION Y-Y

THIS DRAWING CONTAINS INFORMATION THAT IS PROPRIETARY TO MOLEX ELECTRONIC TECHNOLOGIES, LLC AND SHOULD NOT BE USED WITHOUT WRITTEN PERMISSION					
SYMBOLS	DIMENSION UNITS	SCALE	CURRENT REV DESC:		
▽ = 0	mm	4:1	EC NO: 607930		
▽ = 0	GENERAL TOLERANCES (UNLESS SPECIFIED)		DRWN: HKLIANG	2018/11/09	
▽ = 0	ANGULAR TOL ± 3.0°		CHK'D: JDENG02	2018/12/04	
▽ = 0	4 PLACES	±	APPR: JDENG02	2018/12/04	
▽ = 0	3 PLACES	±	INITIAL REVISION:		
▽ = 0	2 PLACES	± 0.1	DRWN: DGRIFITHS	2005/08/26	
▽ = 0	1 PLACE	± 0.3	APPR: smarceau	2005/08/29	
▽ = 0	0 PLACES	±	THIRD ANGLE PROJECTION		
□ = 0	DRAFT WHERE APPLICABLE MUST REMAIN WITHIN DIMENSIONS		DRAWING	SERIES	MATERIAL NUMBER
▽ = 0			D-SIZE	33481	CUSTOMER
					SHEET NUMBER
					3 OF 5

**molex**

MX150 1X4 BLADE SEALED ASSEMBLY MAT SEAL

PRODUCT CUSTOMER DRAWING

DOCUMENT NUMBER	DOC TYPE	DOC PART	REVISION
SD-33481-041	PSD	001	W2

DOCUMENT STATUS	P1	RELEASE DATE	2018/12/04	17:46:22
-----------------	----	--------------	------------	----------

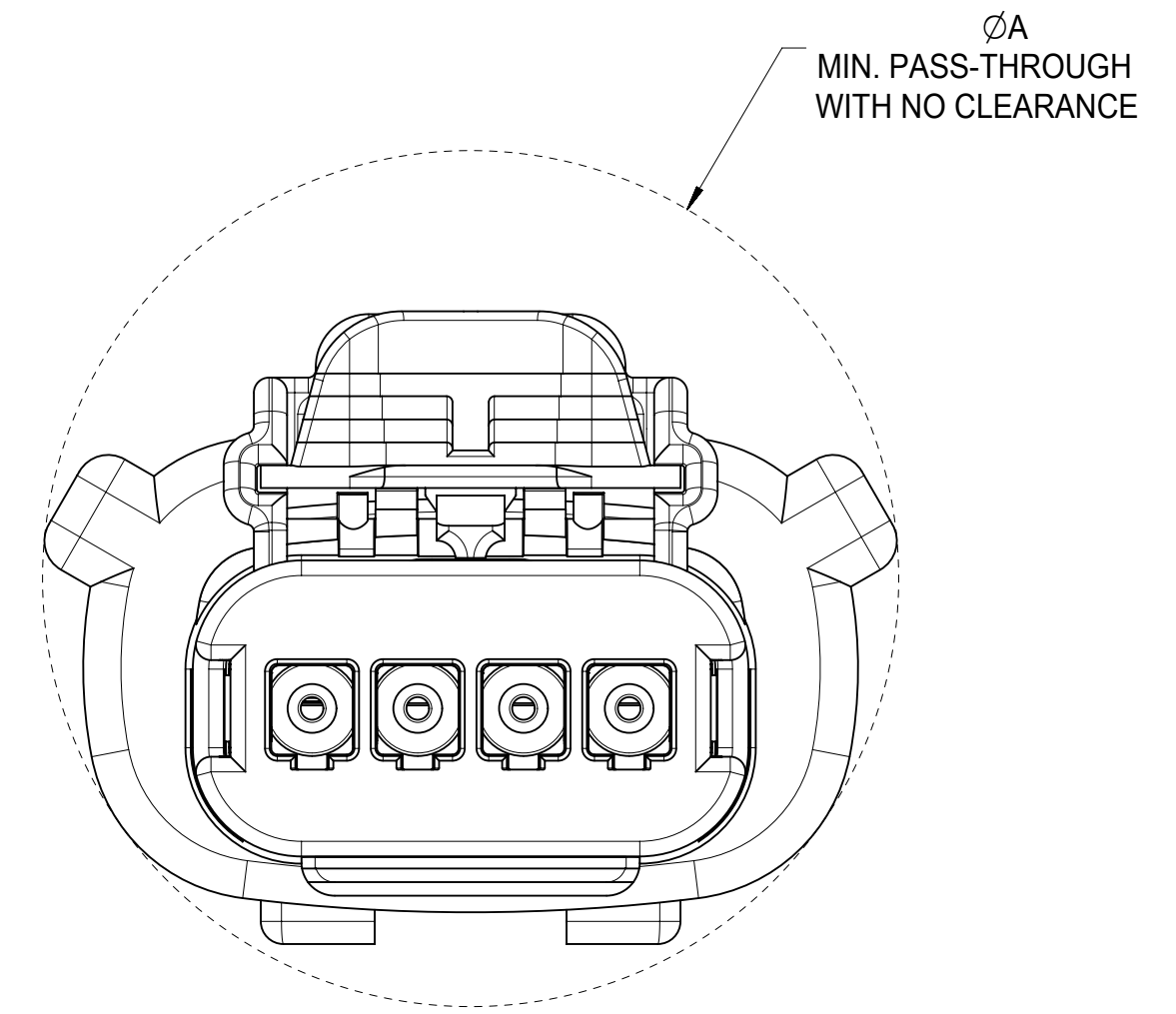
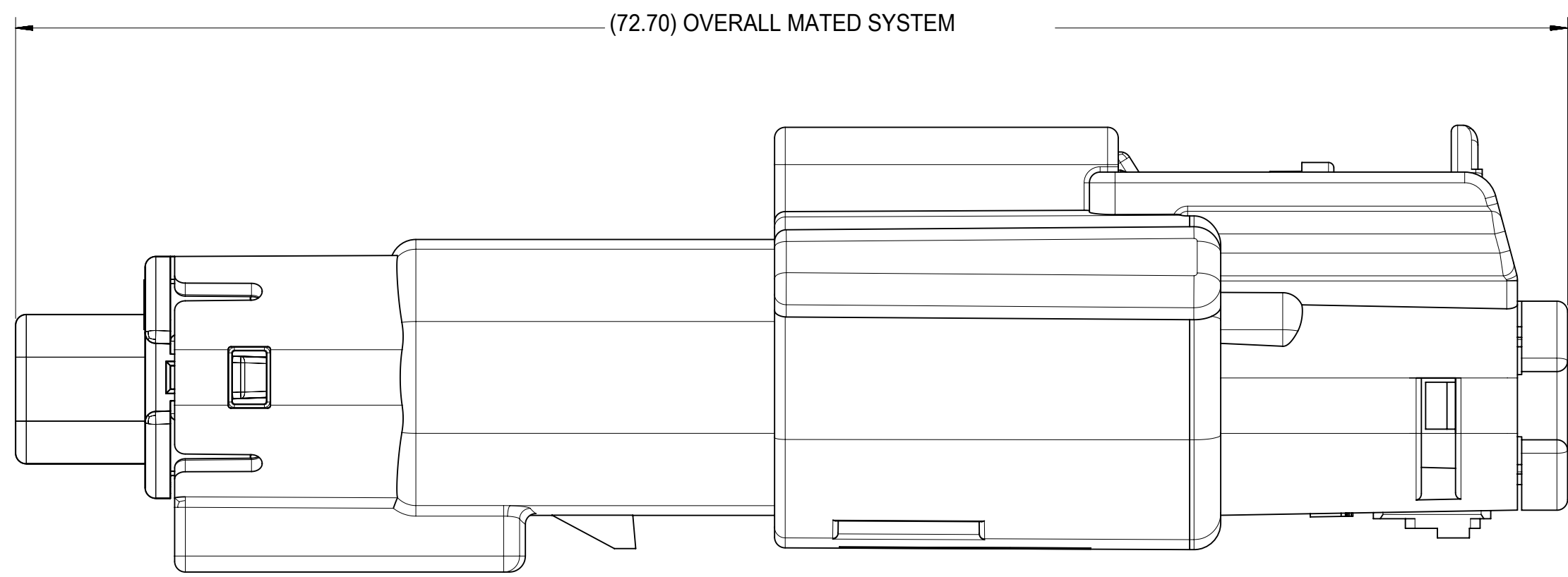

CONFIGURATION		A
MX150 1X4 RECPT SEALED ASSY - STANDARD		29.14
MX150 1X4 RECPT SEALED ASSY - ERGO		29.33
MX150 1X4 RECPT SEALED ASSY - SHORTING (SHRT) BAR		29.14

THIS DRAWING CONTAINS INFORMATION THAT IS PROPRIETARY TO MOLEX ELECTRONIC TECHNOLOGIES, LLC AND SHOULD NOT BE USED WITHOUT WRITTEN PERMISSION									
SYMBOLS		DIMENSION UNITS	SCALE	CURRENT REV DESC:					
▽ = 0	mm	4:1	EC NO: 607930			<b>MX150 1X4 BLADE SEALED ASSEMBLY MAT SEAL</b>			
▽ = 0	GENERAL TOLERANCES (UNLESS SPECIFIED)		DRWN: HKLIANG 2018/11/09						
▽ = 0	ANGULAR TOL ± 3.0°		CHK'D: JDENG02 2018/12/04			<b>PRODUCT CUSTOMER DRAWING</b>			
▽ = 0	4 PLACES ±		APPR: JDENG02 2018/12/04						
▽ = 0	3 PLACES ±		INITIAL REVISION:			DOCUMENT NUMBER: <b>SD-33481-041</b> DOC TYPE: PSD    DOC PART: 001    REVISION: <b>W2</b>			
▽ = 0	2 PLACES ± 0.1		DRWN: DGRIFITHS 2005/08/26						
▽ = 0	1 PLACE ± 0.3		APPR: smarceau 2005/08/29			MATERIAL NUMBER:    CUSTOMER: <b>GENERAL MARKET</b> SHEET NUMBER: <b>4 OF 5</b>			
▽ = 0	0 PLACES ±		DRAFT WHERE APPLICABLE MUST REMAIN WITHIN DIMENSIONS						
▽ = 0	DRAFT WHERE APPLICABLE MUST REMAIN WITHIN DIMENSIONS		THIRD ANGLE PROJECTION		DRAWING: <b>D-SIZE</b>		SERIES: <b>33481</b>		SHEET NUMBER: <b>4 OF 5</b>

ASSEMBLY PART NUMBER	COLOR	KEYING OPTION	CAVITY TYPE & STATUS (X = PLUGGED)				STATUS	COMMENTS
			1	2	3	4		
33481-0401	BLACK	A						
33481-0402	LT. GRAY	B						
33481-0403	BROWN	C						NOT RECOMMENDED, SEE P/N 33481-0424
33481-0404	GREEN	D						NOT RECOMMENDED, SEE P/N 33481-0425
33481-0405	BLACK	C						
33481-0406	BLACK	A				X		
33481-0407	LT. GRAY	B				X		
33481-0408	BROWN	C				X		
33481-0409	GREEN	D				X		
33481-0410	CUSTOM	TBD				X		
33481-0411	BLACK	A	X			X		
33481-0412	LT. GRAY	B	X			X		
33481-0413	BROWN	C	X			X		
33481-0414	GREEN	D	X			X		
33481-0415	CUSTOM	TBD	X			X		
33481-0416	BLACK	A	X	X	X	X		
33481-0417	LT. GRAY	B	X	X	X	X		
33481-0418	BROWN	C	X	X	X	X		NOT RECOMMENDED, SEE P/N 33481-0426
33481-0419	GREEN	D	X	X	X	X		NOT RECOMMENDED, SEE P/N 33481-0427
33481-0420	CUSTOM	TBD	X	X	X	X		
33481-0421	BLACK	A			X			
33481-0422	BLACK	A			X	X		
33481-0423	LT. GRAY	B	X	X				
33481-0424	DK. GRAY	C						
33481-0425	ST. GRAY	D						
33481-0426	DK. GRAY	C	X	X	X	X		
33481-0427	ST. GRAY	D	X	X	X	X		
33481-0428	YELLOW	A						
33481-0429	LT. GRAY	B		X	X			
33481-0430	BLACK	A	X		X			

W2

ASSEMBLY PART NUMBER	COLOR	KEYING OPTION	CAVITY TYPE & STATUS (X = PLUGGED)				STATUS	COMMENTS
			1	2	3	4		
33481-4401	BLACK	A						
33481-4402	LT. GRAY	B						
33481-4403	BROWN	C						NOT RECOMMENDED, SEE P/N 33481-4424
33481-4404	GREEN	D						NOT RECOMMENDED, SEE P/N 33481-4425
33481-4405	BLACK	C						
33481-4406	BLACK	A				X		
33481-4407	LT. GRAY	B				X		
33481-4408	BROWN	C				X		
33481-4409	GREEN	D				X		
33481-4410	CUSTOM	TBD				X		
33481-4411	BLACK	A	X			X		
33481-4412	LT. GRAY	B	X			X		
33481-4413	BROWN	C	X			X		
33481-4414	GREEN	D	X			X		
33481-4415	CUSTOM	TBD	X			X		
33481-4416	BLACK	A	X	X	X	X		
33481-4417	LT. GRAY	B	X	X	X	X		
33481-4418	BROWN	C	X	X	X	X		NOT RECOMMENDED, SEE P/N 33481-4426
33481-4419	GREEN	D	X	X	X	X		NOT RECOMMENDED, SEE P/N 33481-4427
33481-4420	CUSTOM	TBD	X	X	X	X		
33481-4421	BLACK	A			X			
33481-4422	BLACK	A			X	X		
33481-4423	LT. GRAY	B	X	X				
33481-4424	DK. GRAY	C						
33481-4425	ST. GRAY	D						
33481-4426	DK. GRAY	C	X	X	X	X		
33481-4427	ST. GRAY	D	X	X	X	X		
33481-4428	YELLOW	A						
33481-4429	LT. GRAY	B		X	X			
33481-4430	BLACK	A	X		X			

W2

SYMBOLS	THIS DRAWING CONTAINS INFORMATION THAT IS PROPRIETARY TO MOLEX ELECTRONIC TECHNOLOGIES, LLC AND SHOULD NOT BE USED WITHOUT WRITTEN PERMISSION		
	DIMENSION UNITS	SCALE	CURRENT REV DESC:
▽ = 0	mm	1:1	EC NO: 607930 DRWN: HKLIANG 2018/11/09 CHK'D: JDENG02 2018/12/04 APPR: JDENG02 2018/12/04 INITIAL REVISION: DRWN: DGRIFITHS 2005/08/26 APPR: smarceau 2005/08/29
▽ = 0	GENERAL TOLERANCES (UNLESS SPECIFIED)		
▽ = 0	ANGULAR TOL ± 3.0°		
▽ = 0	4 PLACES	±	
▽ = 0	3 PLACES	±	
▽ = 0	2 PLACES	± 0.1	
▽ = 0	1 PLACE	± 0.3	
▽ = 0	0 PLACES	±	
□ = 0	DRAFT WHERE APPLICABLE MUST REMAIN WITHIN DIMENSIONS		THIRD ANGLE PROJECTION
▽ = 0			DRAWING D-SIZE
			SERIES 33481
DOCUMENT STATUS P1		RELEASE DATE 2018/12/04	17:46:22

**molex**

MX150 1X4 BLADE  
SEALED ASSEMBLY MAT SEAL

PRODUCT CUSTOMER DRAWING

DOCUMENT NUMBER	DOC TYPE	DOC PART	REVISION
SD-33481-041	PSD	001	W2

MATERIAL NUMBER	CUSTOMER	SHEET NUMBER
	GENERAL MARKET	5 OF 5