

DATE	DESCRIPTION	REV.
10.08.13	CHANGE AS PER ECN 13-091	A
3.30.17	CHANGE AS PER ECN 17-028	B

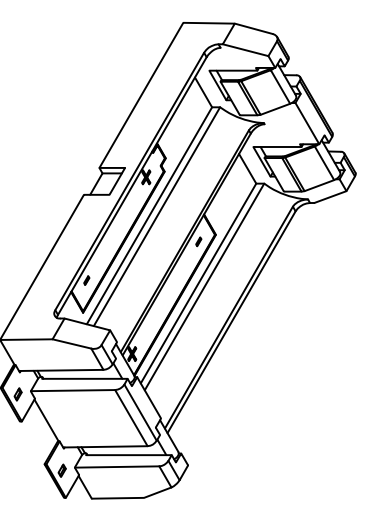
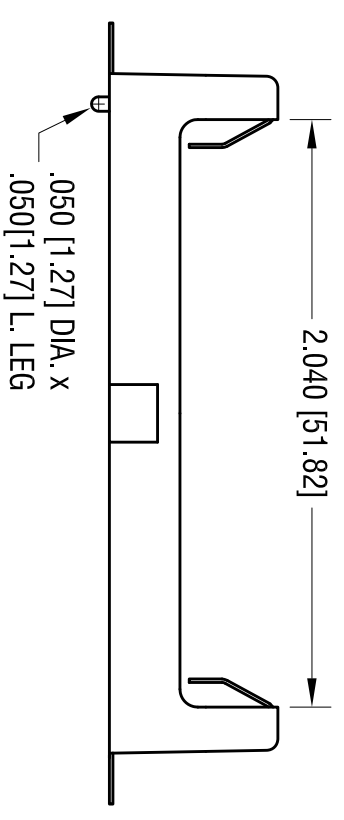
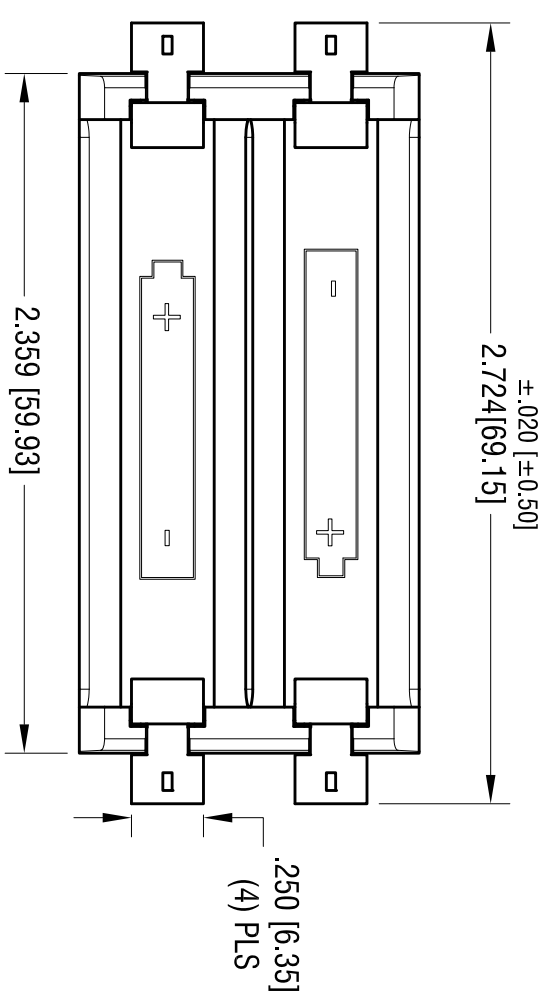
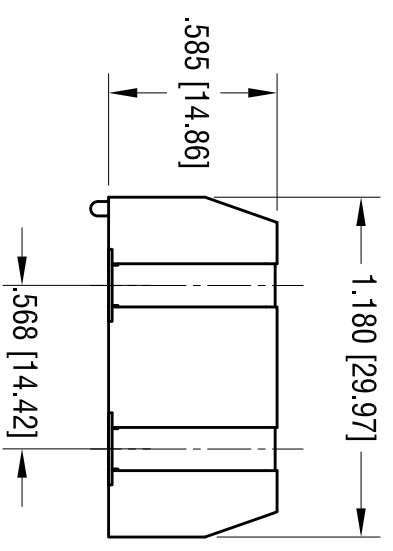
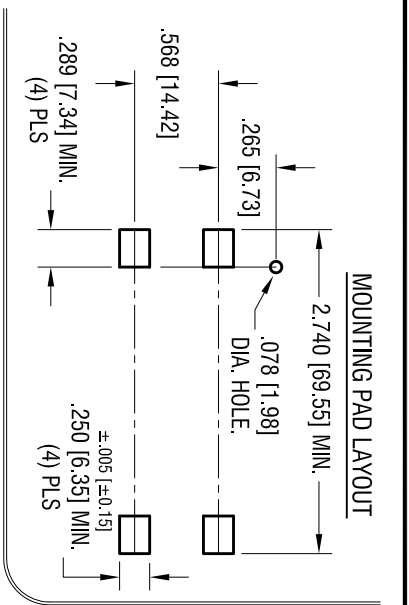

- NOTE:
1. BASE:
MATEL: HEAT RESISTANCE NYLON
(UL 94V-0)
 2. CONTACT:

MATEL: .012 [0.30] THK STAINLESS STEEL
FINISH: GOLD FLASH, OVER NICKEL PLATE.

THIS DOCUMENT IS THE PROPERTY OF KEYSTONE ELECTRONICS CORP. AND SHALL NOT BE REPRODUCED, DISTRIBUTED OR USED AS A BASIS FOR MANUFACTURE WITHOUT PRIOR WRITTEN PERMISSION FROM KEYSTONE ELECTRONICS CORP.

KEYSTONE ELECTRONICS CORP.			
www.keystec.com • ASTORIA, N.Y. 11105-2017 • Tel (718) 956-8900			
PART NAME SM BATTERY HOLDER, (2) AA			
MATERIAL AS NOTED			
FINISH	AS NOTED	DRN BY	NT
TOLERANCES	INCH [MM]	CODE	DWG NO.
DECIMAL	± .010 [± 0.25]	C	
ANGULAR	± 1°		
UNLESS OTHERWISE SPECIFIED		App'D	LN
		SCALE	1.5X
		DATE	5.18.10
			1012

Mouser Electronics

Authorized Distributor

Click to View Pricing, Inventory, Delivery & Lifecycle Information:

[Keystone Electronics:](#)

[1012](#)