

THIS DRAWING IS UNPUBLISHED. RELEASED FOR PUBLICATION
 © COPYRIGHT 2005 BY TYCO ELECTRONICS CORPORATION. ALL RIGHTS RESERVED.

LOC	DIST	REVISIONS			
P	LTR	DESCRIPTION	DATE	DWN	APVD
AJ	16				
	N2	REVISED PER ECO 06-018711	30AUG2006	MC	JH

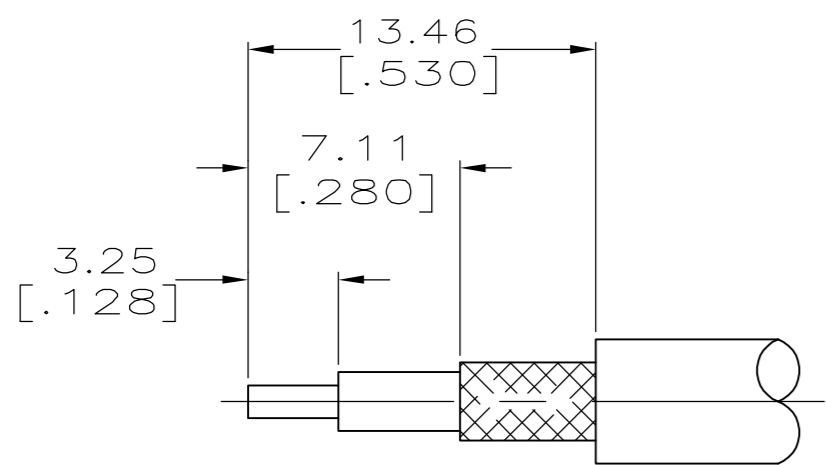

RECOMMENDED STRIP LENGTHS
SCALE NTS

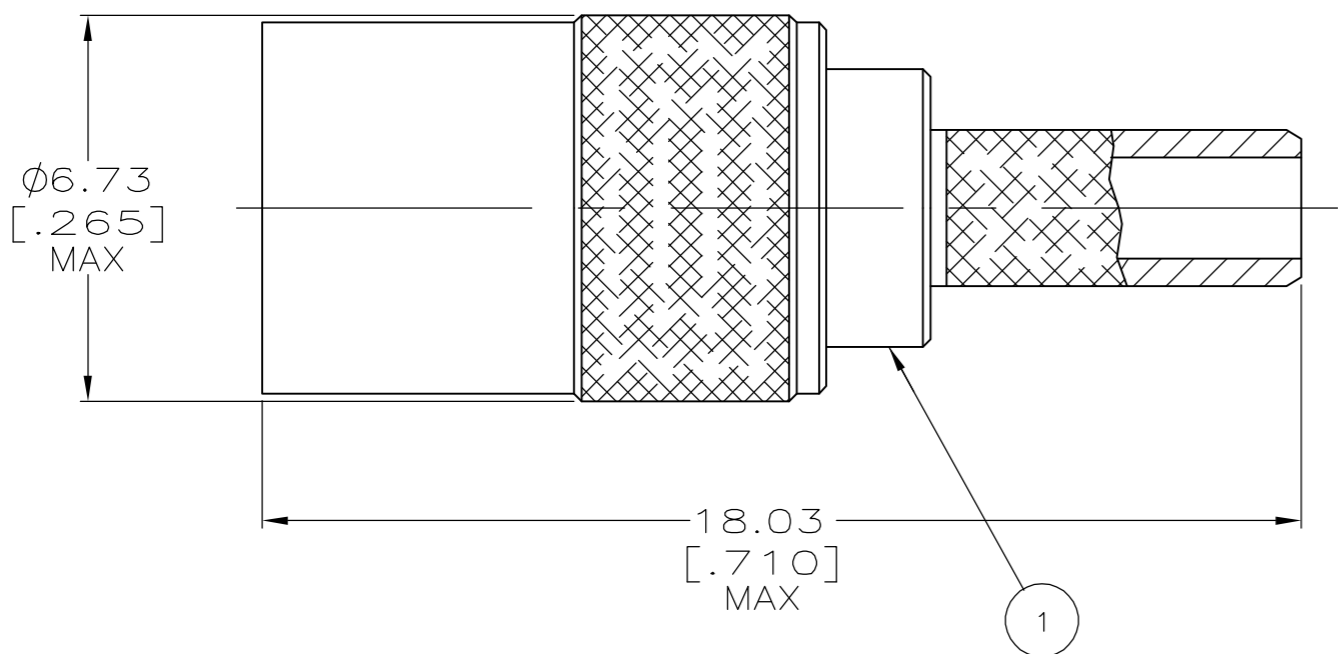

- △1 FINISHES:
BODY: NICKEL PLATE PER QQ-N-290
CONTACT: GOLD PLATE PER MIL-G-45204
OUTER CONTACT: GOLD PLATE PER MIL-G-45204
- △2 FINISHES:
BODY: NICKEL PLATE PER QQ-N-290
CONTACT: GOLD PLATE PER MIL-G-45204
OUTER CONTACT: NICKEL PLATE PER QQ-N-290
- 3. INTERFACE PER MIL-C-39012
- 4. SEE I.S. SHEET 408-2987-12.
- △5 SIGHT HOLE ON PART NUMBER 1-414946-0 ONLY.
- △6 SEE DRAWINGS 414946-1 AND 1-414946-2 FOR INFORMATION SPECIFIC TO THESE PART NUMBERS.

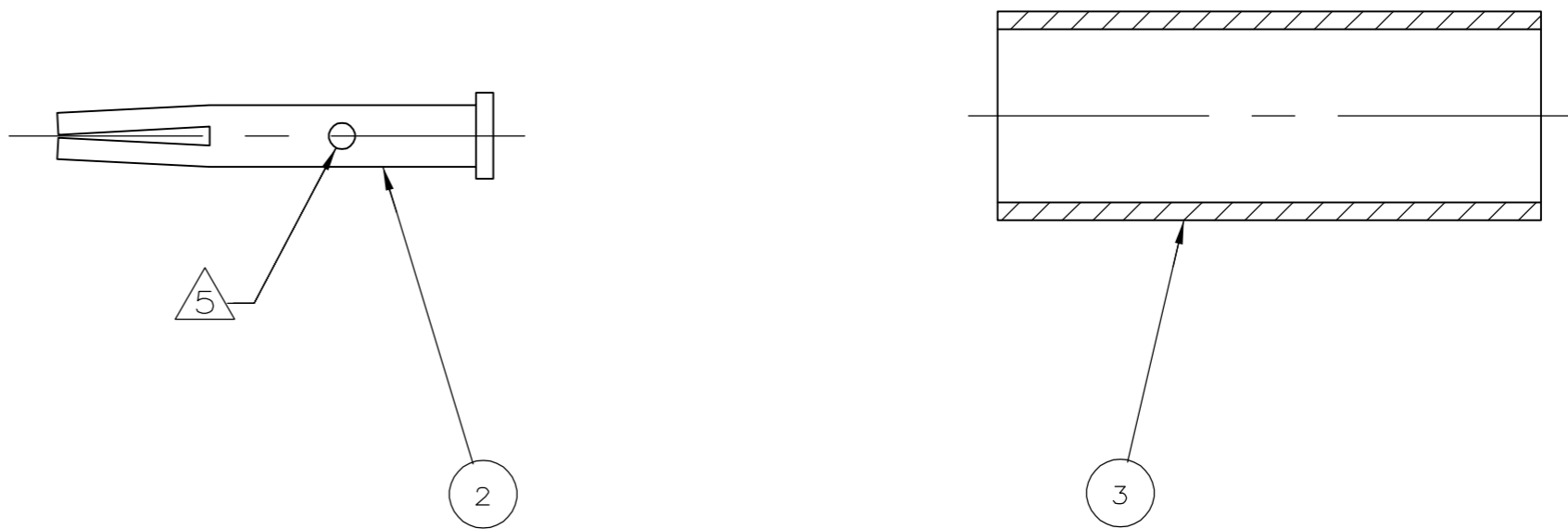

POSITION LETTER	AMP DIE SET	HEX SIZE	DANIELS DIE SET	SELECTOR NUMBER	DANIELS POSITIONER	NOTES	CABLE	③ FERRULE QTY=1	② CONTACT QTY=1	① PLUG ASSY QTY=1	PART NO	
△6	-	-	-	-	-	-	-	-	-	-	1-414946-2	
B	58483-1	.128	HX4-1637	4	K699	△1	RG-179	2-446556-1	228278-4	414958-1	1-414946-1	
OBSOLETE	C	58483-1	.151	HX4-1637	4	K699	△1	HP 8120-0552-1	1-413889-4	415630-4	414958-1	1-414946-0
SUPERSEDED BY 414946-6	B	58483-1	.128	HX4-1637	4	K699	△2	RG-179	1-413889-3	228278-4	414958-2	414946-9
SUPERSEDED BY 414946-5	B	58483-1	.128	HX4-1637	4	K699	△1	RG-179	1-413889-3	228278-4	414958-1	414946-8
SUPERSEDED BY 414946-5	B	58483-1	.128	HX4-1637	4	K699	△1	RG-179	1-413889-3	228278-4	414958-1	414946-7
	B	58483-1	.128	HX4-1637	4	K699	△2	RG-179	1-413889-3	228278-4	414958-2	414946-6
	B	58483-1	.128	HX4-1637	4	K699	△1	RG-179	1-413889-3	228278-4	414958-1	414946-5
OBSOLETE	C	58483-1	.151	HX4-1637	4	K699	△2	RD-316	1-413889-4	228203-4	414958-2	414946-4
OBSOLETE	C	58483-1	.151	HX4-1637	4	K699	△1	RD-316	1-413889-4	228203-4	414958-1	414946-3
OBSOLETE	B	58483-1	.128	HX4-1637	4	K699	△2	RG-316 & RG-174	1-413889-3	228203-4	414958-2	414946-2
△6	-	-	-	-	-	-	-	-	-	-	414946-1	

TOOLING INFORMATION

THIS DRAWING IS A CONTROLLED DOCUMENT.

DIMENSIONS: mm [INCHES]	TOLERANCES UNLESS OTHERWISE SPECIFIED: 0 PLC ± - 1 PLC ± - 2 PLC ± 0.25 [.010] 3 PLC ± - 4 PLC ± - ANGLES ± -	DWN B. WERNER 15DEC94 CHK J. McLEOD 19DEC94 APVD J. McLEOD 19DEC94	tyco Electronics Tyco Electronics Corporation Harrisburg, PA 17105-3608
MATERIAL	FINISH △1 △2	PRODUCT SPEC APPLICATION SPEC	NAME 50 OHM PLUG ASSY,STR SMB
		WEIGHT	SIZE CAGE CODE DRAWING NO RESTRICTED TO A2 00779 C=414946 -
		CUSTOMER DRAWING	SCALE 8:1 SHEET 1 of 1 REV N2

414946 4946

Mouser Electronics

Authorized Distributor

Click to View Pricing, Inventory, Delivery & Lifecycle Information:

[TE Connectivity:](#)

[414946-5](#)