

POUR INFORMATION
FOR INFORMATION

VUE AVANT ACCOUPLEMENT (ACCOSTAGE)
VIEW BEFORE MATING (ACCOUSTING)

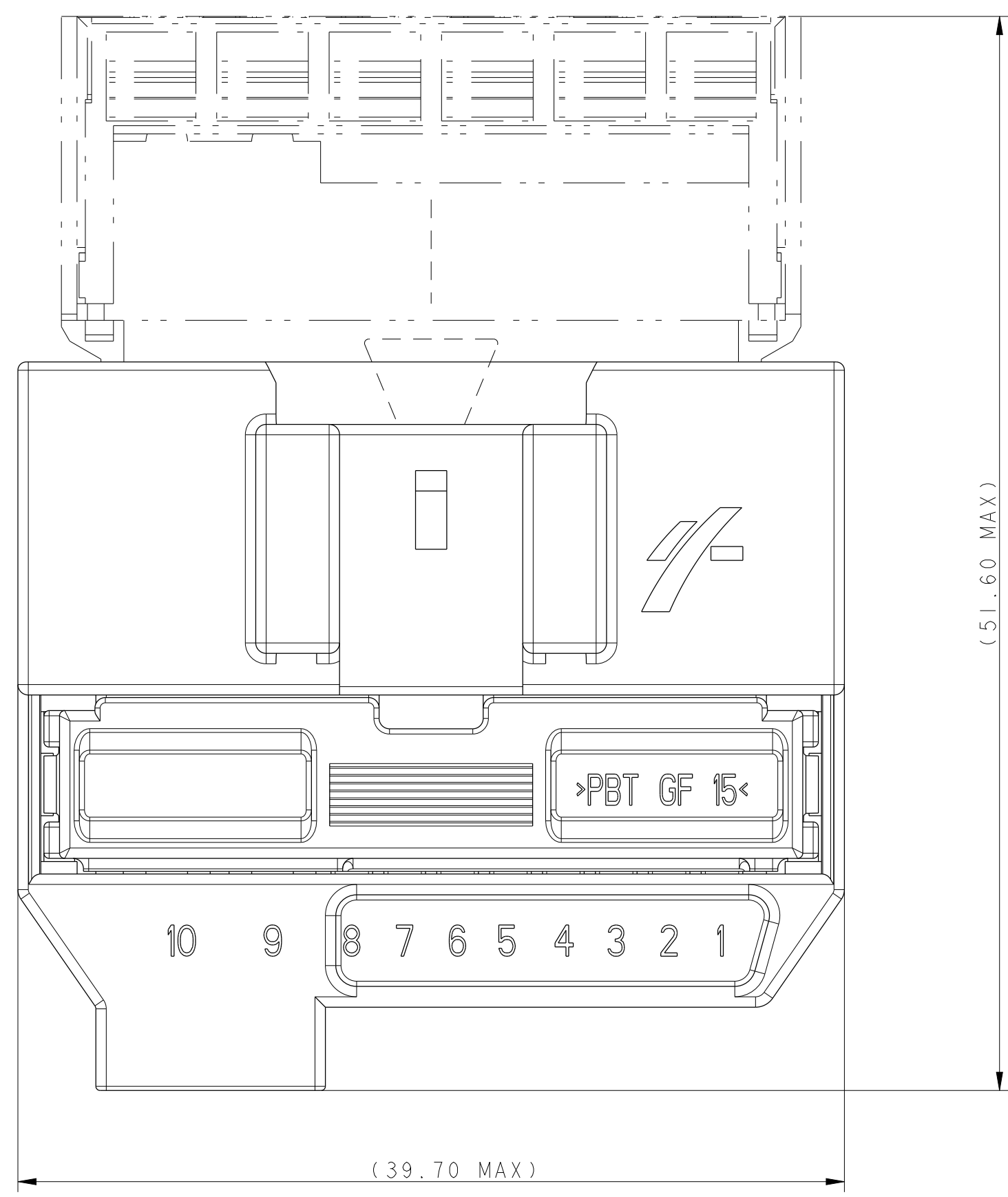

ECHELLE / SCALE 3:1

VUE APRES ACCOUPLEMENT
VIEW AFTER MATING

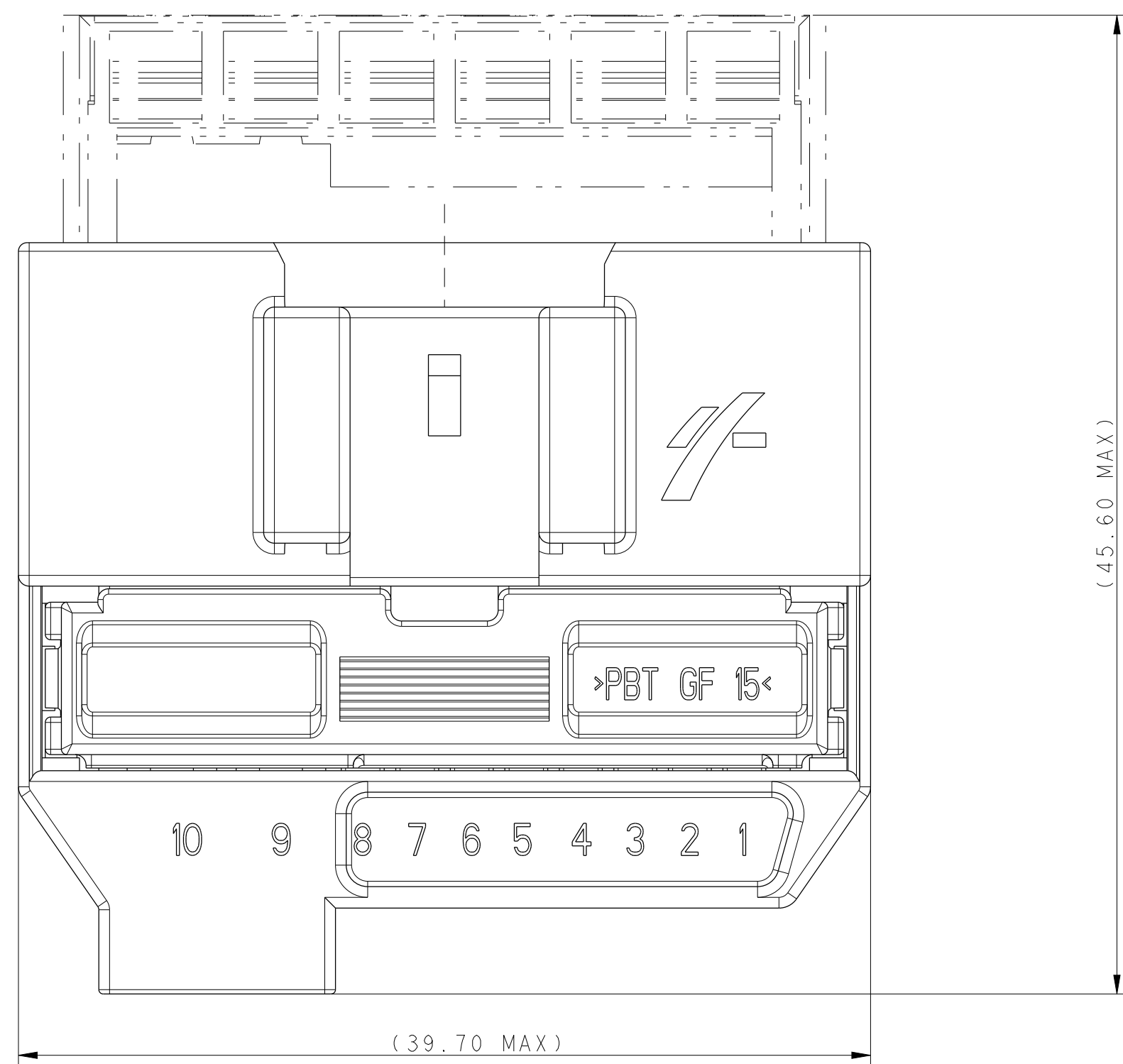

ECHELLE / SCALE 3:1

INTERFACE AVEC ATTACHE C.P.I.O.
FOOTPRINT WITH C.P.I.O. FASTENER

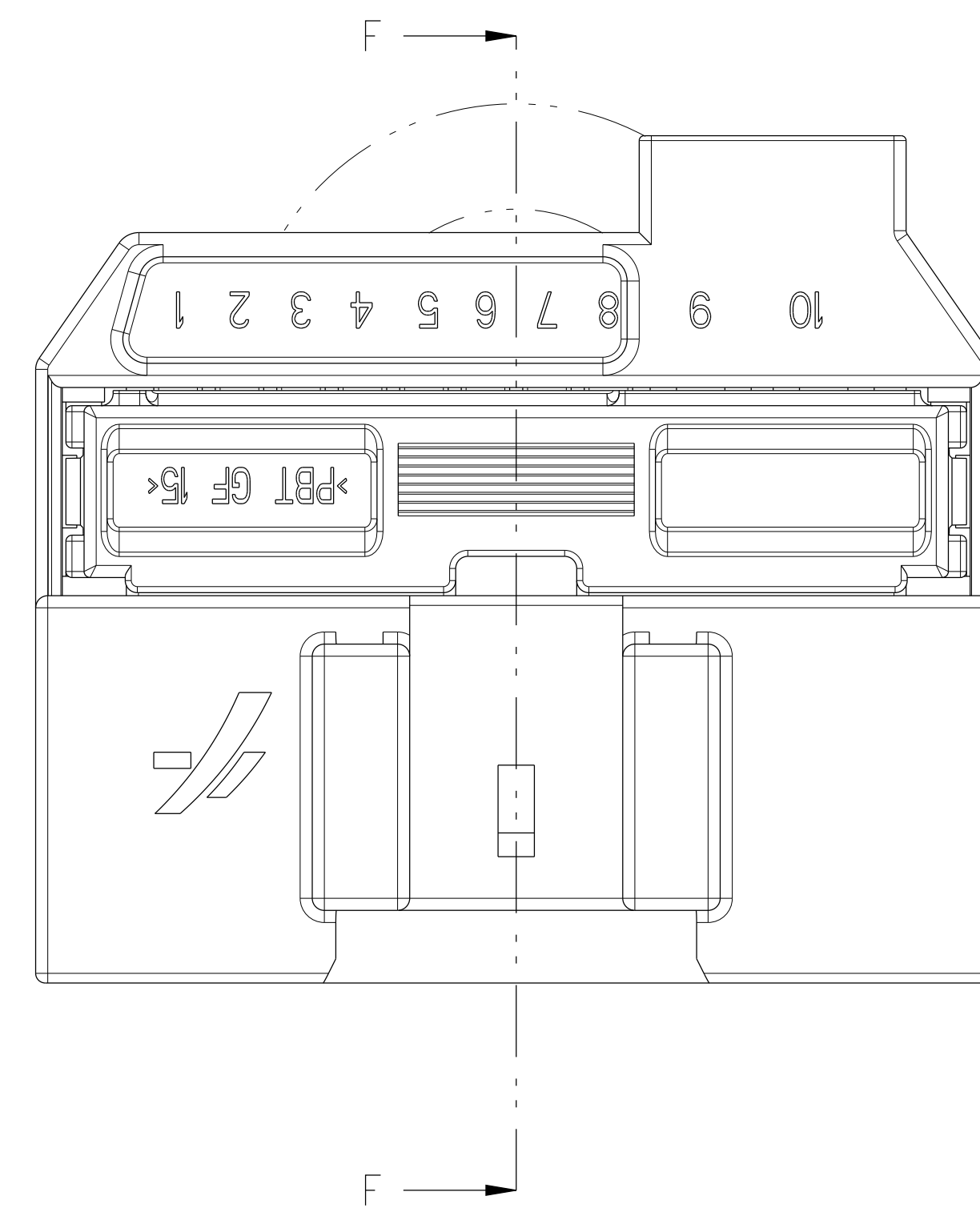
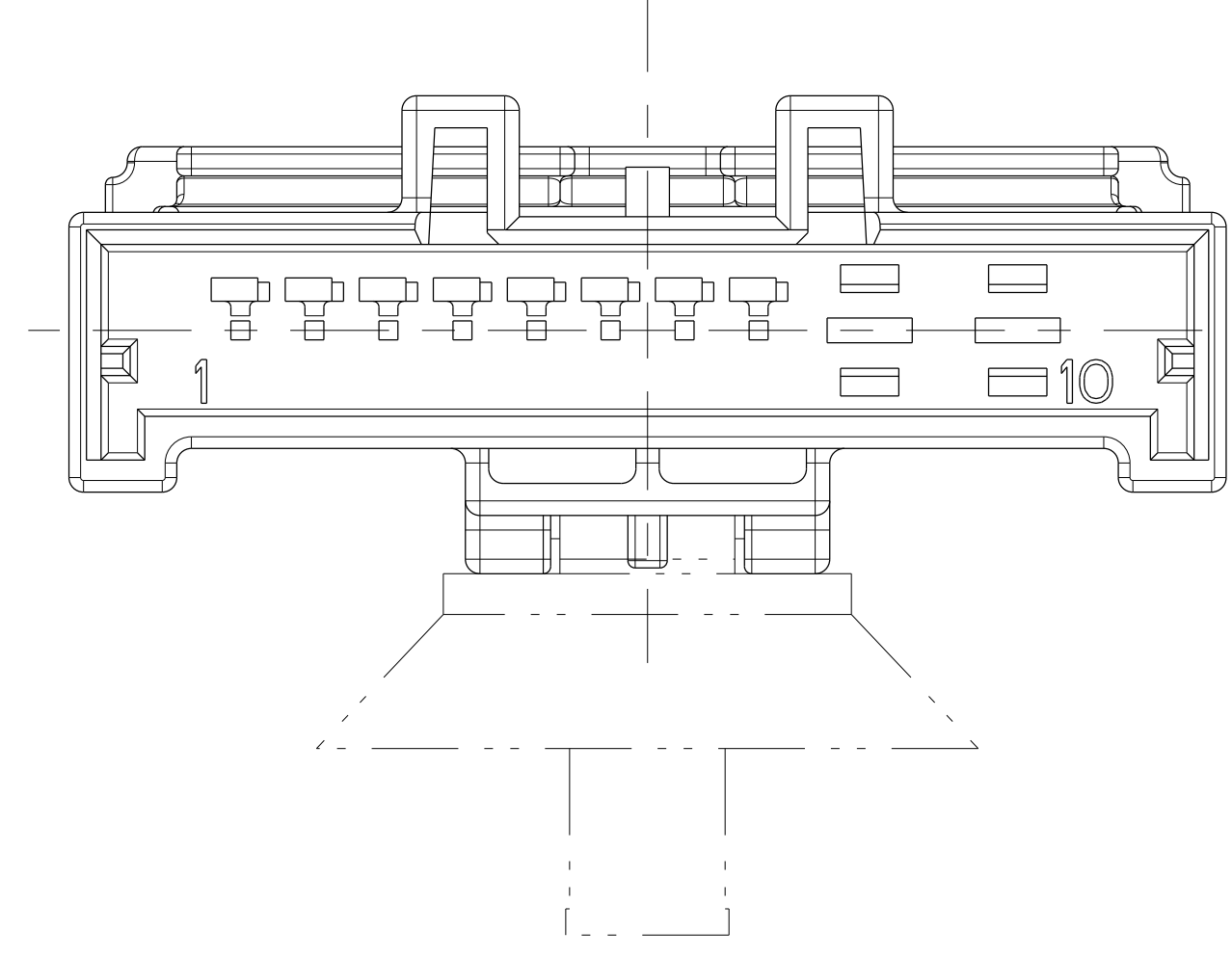

COUPE / SECTION F-F

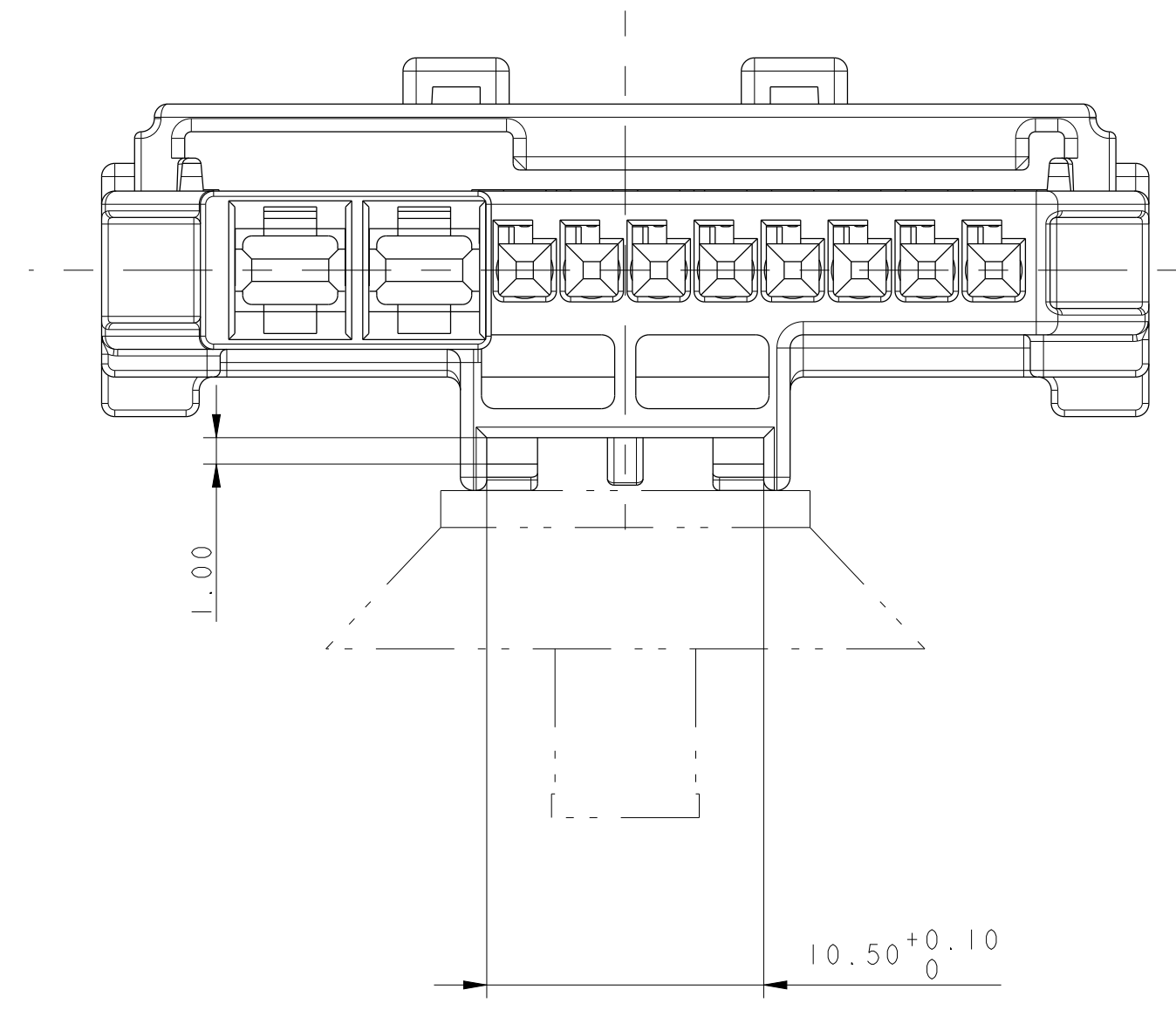
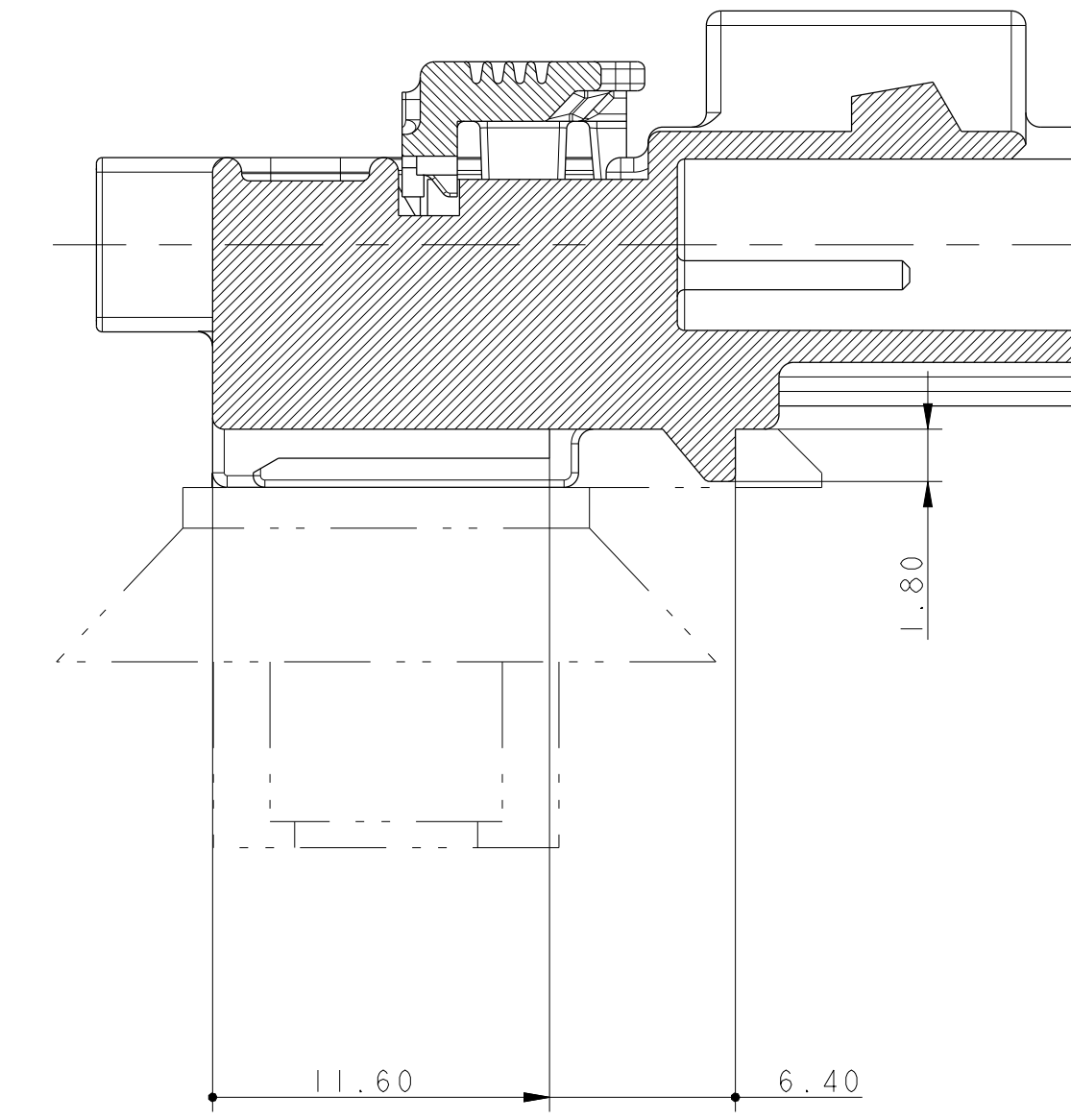

TABLE DES VERSIONS / VERSIONS LIST

COULEUR CODAGE CODING COLOUR	NOIR BLACK	BLEU BLUE	GRIS GREY	VIOLET PURPLE
REFERENCE DELPHI DELPHI P/N	10820234	10864752	33511079	33511080
INDICE REVISION	01	01	01	01
REFERENCE MVL MVL P/N	250 PL 10 9 S 0 001	250 PL 10 9 S 6 001	250 PL 10 9 S 8 001	250 PL 10 9 S 7 001
INDICE REVISION	A	A	A	A

NOTE: LE MODELE REPRESENTE EST LE CODAGE NOIR
NOTE: THE SHOWN VERSION IS THE BLACK ONE

ECN NO.	POSITION	CHANGE DESCRIPTION
		INITIAL RELEASE

PROJETS	PROJETS	PROJETS	PROJETS
10-WAY MALE CONNECTOR	10-WAY MALE CONNECTOR	10-WAY MALE CONNECTOR	10-WAY MALE CONNECTOR

DATE	DESCRIPTION	INITIALS
	10-WAY MALE CONNECTOR	

NOTE: Ce plan étant un extrait du plan de définition, on fera référence pour tout litige au plan de définition. Toute cote non respectée sur un lot donnera lieu au refus du lot.
NOTE: The present drawing being an abstract of the definition drawing, any dispute will be referred to the definition drawing. Any wrong dimension of one part in one batch will entail rejection of the whole batch.

Mouser Electronics

Authorized Distributor

Click to View Pricing, Inventory, Delivery & Lifecycle Information:

[Aptiv:](#)

[250PL109S0001](#) [250PL109S6001](#) [250PL109S0001-B](#)