

KEY PRODUCT CHARACTERISTICS

SAFETY/COMPLIANCE	FIT/FUNCTION	TOTAL ON DRAWING	1	
S/C CHECKPOINTS	F/F CHECKPOINTS	LAST NO. USED	1	
NO & TYPE	DESCRIPTION	RATIONALE	PTS	ZONE
1	FF	DIAMETER		D10

SYMBOL DEFINITION

A DIMENSION WITHOUT AN INSPECTION REPORT SYMBOL DOES NOT REQUIRE INSPECTION. IT MAY BE CONTROLLED ON THE INDIVIDUAL COMPONENT DRAWING.

TOTAL NO OF INSPECTIONS REQUIRED	5
LAST NO. USED	5

MISSING SYMBOLS

DATE	STG	REV	N/P	CHG	ZONE	REVISION HISTORY	AUTH	DR	APVD1	APVD2
23SE09	R	01	-	-		ALL PARTS - CREATED PART DRAWING	408719	CM	CM	PDP
03NO09	R	02	-	-		ALL ACTIVE PARTS - ADDED LUBE TERMINAL NOTE	409377	FRE	JVM	PDP
28JA10	R	03	-	-		SHEET 1 OF 2 WAS SHEET 1 OF 1. ADDED COLUMN "TYPE" TO THE CHART.	409761	MB	MB	YD
09AP10	R	04	-	-		ALL ACTIVE PARTS - DIMS (26.88) WAS (26.16) AND 15.29 WAS 14.57	410522	ECB	ECB	PDP
14JN10	R	05	-	-		13783269 & 13783284 - REVISED GRAPHICS	411065	EVV	EVV	PDP
29JL10	R	06	-	-		13783269 - CORRECTED PART NUMBER	411466	JRL	JRL	GR
28FE11	R	07	-	-		ALL ACTIVE PARTS - ADDED NOTES "TERMINAL CAN BE USED..." AND "TERMINAL IS A DIRECT..."	413483	CBG	CBG	PDP
03MY11	R	08	-	-		ALL ACTIVE PARTS - UPDATED PDM ATTRIBUTES	414071	AJP	JAA	PDP
07JN11	R	09	-	-		ALL ACTIVE PARTS - UPDATED PDM ATTRIBUTES	414464	AJP	JAA	PDP
22JN11	R	10	-	-		ALL ACTIVE PARTS - ADDED CABLE CORE STRANDS LABEL	414558	AGM	JVM	PDP
08JL11	R	11	-	-		ALL ACTIVE PARTS - UPDATED PDM ATTRIBUTES	414764	CBG	CBG	PDP
06SE11	R	12	-	-		ALL ACTIVE PARTS - REMOVED "MAX CURRENT CAPACITY" & "INSULATION CRIMP" NOTES	415287	MRC	JVM	PDP
14OC11	R	13	-	-		ALL PARTS - ADDED TERMINAL APPLICATION INFORMATION NOTE	415781	JCF	JVM	PGD
30JA13	R	14	-	-		ALL AVAILABLE PARTS - UPDATED PDM ATTRIBUTES	421281	JLP	JVM	PGD
20MR13	R	15	-	-		ALL AVAILABLE PARTS - ADDED KPC SYMBOL (1 PLC) & CHART	421801	AJP	JVM	PGD

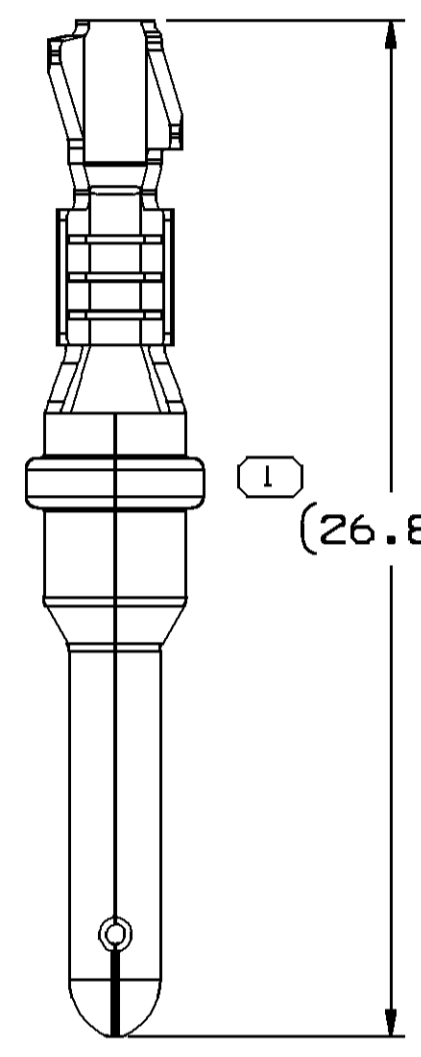
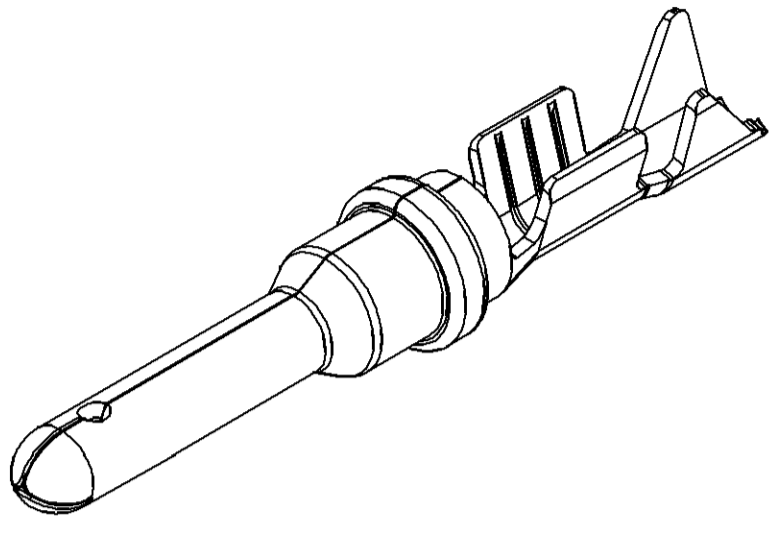

THIS DIMENSION CREATED AT CARRIER CUTOFF

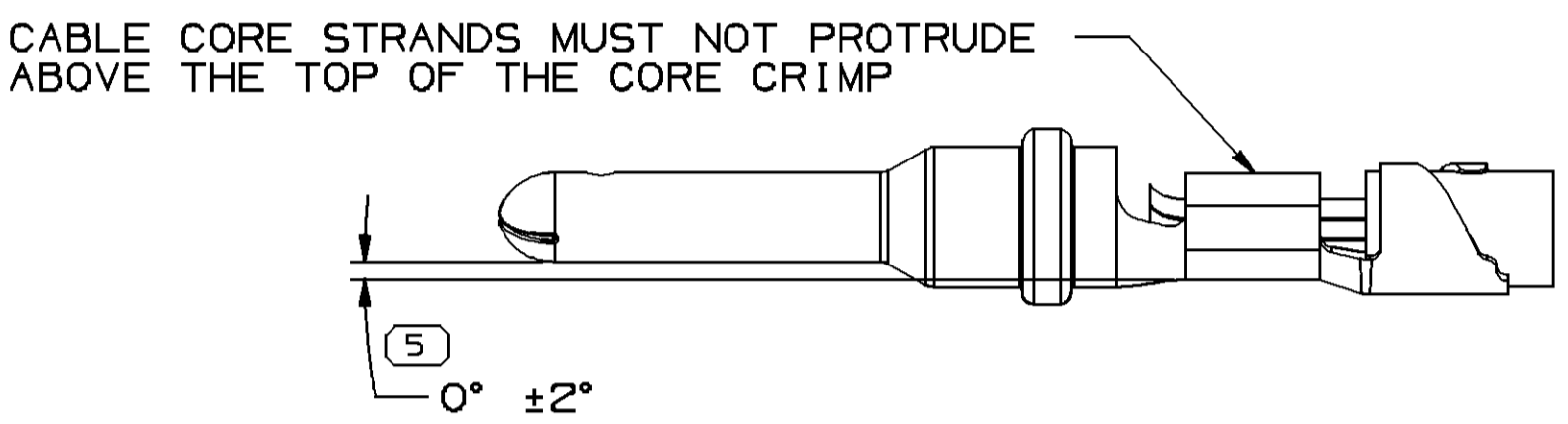

CRIMPED TERMINAL AND CABLE ALIGNMENT

NOTES

- UNLESS OTHERWISE SPECIFIED AND/OR INDICATED: DIMENSIONS ARE TO FACE OF VIEW SHOWN AND AUTOMATICALLY ROUNDED BY COMPUTER FOR INSPECTION (SEE MATH MODEL FOR PRECISE DIMENSIONS). FOR ALL OTHER DIMENSIONS NOT SHOWN BUT REQUIRED FOR TOOL BUILD, SEE MATH MODEL FOR PRECISE TOOL PATH DATA.
- TERMINAL MUST BE MADE USING NYE 1486 OIL WITH UV TRACE ADDED (NYE LUBRICANTS) MIXED 50/50 WITH FIN LUBE 0177 (PPG INDUSTRIES SPECIALTY PRODUCTS) DURING THE FORM PROCESS. AFTER STAMPING, NYE OIL MUST BE PRESENT ON THE MATING INTERFACE AREA AND ON THE OUTSIDE SURFACE OF THE CRIMP WINGS. THE RECOMMENDED APPLICATION METHOD UTILIZES A MIXTURE QUANTITY OF 0.75 GALLONS PER MILLION TERMINALS. ANY DEVIATION FROM THIS LUBRICANT MUST BE APPROVED BY DELPHI PACKARD PRODUCT ENGINEERING.
- REFER TO DRAWING NUMBER 13922721 FOR TERMINAL APPLICATION INFORMATION (CURRENT CARRYING CAPABILITY, CABLE RANGE, ETC.)

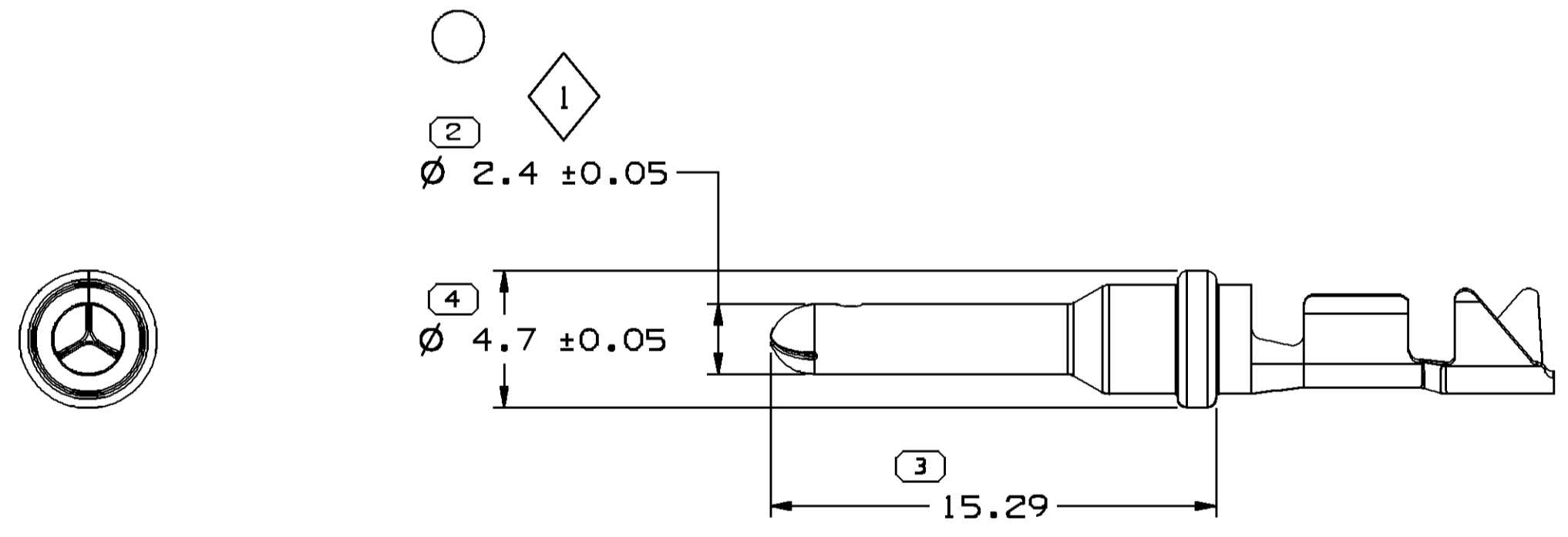

TYPE 101

MATERIAL NOTES:

- TERMINAL CAN BE USED IN ANY INDUSTRY STANDARD 2.4 MM (SIZE 12 MIL 39029) CAVITY. EXAMPLE DEUTSCH DTP.
- TERMINAL IS A DIRECT REPLACEMENT FOR (EQUIVALENT TO) THE DEUTSCH 1060-12-XXXX FAMILY OF STAMPED AND FORMED CONTACTS.

13783285	01		GOLD	4 - 6	10	4 - 5.7	101	13783302
13783270	01		NICKEL	4 - 6	10	4 - 5.7	101	13783294
13783284	03	AJ	GOLD	4 - 6	10T	3.4 - 4.8	101	13783301
13783269	03	AK	NICKEL	4 - 6	10T	3.4 - 4.8	101	13783293
13783283	02	AJ	GOLD	2 - 3	13	2.89 - 4.21	101	13783300
13783268	02	AJ	NICKEL	2 - 3	13	2.89 - 4.21	101	13783292
13783282	02	AJ	GOLD	2 - 3	13T	2.4 - 3.35	101	13783299
13783267	02	AJ	NICKEL	2 - 3	13T	2.4 - 3.35	101	13783291
13783280	02	AJ	GOLD	1.5 - 2.5	14	2.6 - 3.7	101	13783298
13783266	02	AJ	NICKEL	1.5 - 2.5	14	2.6 - 3.7	101	13783290
13783277	02	AJ	GOLD	1.5 - 2.5	14T	2.1 - 3	101	13783297
13783265	02	AJ	NICKEL	1.5 - 2.5	14T	2.1 - 3	101	13783289
13783276	02	AJ	GOLD	0.75 - 1	17	2.2 - 3.1	101	13783296
13783264	02	AJ	NICKEL	0.75 - 1	17	2.2 - 3.1	101	13783288
13783273	02	AJ	GOLD	0.75 - 1	17T	1.6 - 2.25	101	13783295
13783263	02	AJ	NICKEL	0.75 - 1	17T	1.6 - 2.2	101	13783287
PART NO	REV	N/P	CONTACT PLATING	SIZE (MM²)	ID	DIA	TYPE	MATING TERMINAL
			PLATED					CABLE

LINE DRAWN THROUGH A PART NUMBER INDICATES THAT PHYSICAL PARTS ARE NOT AVAILABLE FOR ORDERING.

PART NUMBERS THAT DO NOT HAVE A LINE PRESENT INDICATE THAT PHYSICAL PARTS ARE AVAILABLE FOR ORDERING.

CONTACT DELPHI SALES TO ASSURE AVAILABILITY OF PARTS.

REVISED 2013

DWG TYPE: PART DRAWING

STYLE: D

VOLUME (CPI): D

DISTR CODE: D

UNLESS OTHERWISE SPECIFIED THIS DOCUMENT IS IN ACCORDANCE WITH ASME Y14.5M-1994 AS AMENDED BY THE GM GLOBAL DIMENSIONING AND TOLERANCING ADDENDUM - 1997. ALL GEOMETRIC TOLERANCES AND RELATED DATUMS APPLY RFS. RULE #1 (PERFECT FORM AT MMVD) DOES NOT APPLY WHEN RELATIONSHIP BETWEEN FEATURES IS ESTABLISHED BY ORIENTATION OR LOCATION TOLERANCES. SEPARATE POSITION CALLOUTS MAY BE GAGED SEPARATELY, REGARDLESS OF DATUM REFERENCE. ALL DIMENSIONS ARE IN MILLIMETERS.

REFERENCE:

THIRD ANGLE PROJECTION

DO NOT SCALE

USE MATH DATA

ANGULAR TOLERANCE ±2°

DELPHI

DELPHI PACKARD ELECTRICAL/ELECTRONIC ARCHITECTURE

WARREN, OH

COPYRIGHT 2009 DELPHI CORPORATION AND/OR ITS AFFILIATES. ALL RIGHTS RESERVED.

THIS DRAWING IS THE PROPERTY OF DELPHI CORPORATION AND CONTAINS DELPHI CONFIDENTIAL INFORMATION. THE REPRODUCTION, DISTRIBUTION AND UTILIZATION OF THIS DOCUMENT OR ITS RELATED CAD MATH DATA, AS WELL AS COMMUNICATION OF ANY CONTENT TO OTHERS, WITHOUT EXPRESS AUTHORIZATION, IS PROHIBITED.

DATE: 23SE09

DR: C. MARGRAVE

APVD1: C. MARGRAVE

APVD2: C. MARGRAVE

APVD3: PAUL DEPOMPEI

APVD4: 24SE09

APVD5:

SUBSTANCES OF CONCERN AND RECYCLED CONTENT PER DELPHI 10949001

MATERIAL: COPPER ALLOY

DRAWING NAME: TAXI TERM M HES 2.4 UNKN

DRAWING NUMBER: 13783262

SIZE: A1

SCALE: 5:1

FRAME NO: 1 OF 1

SHEET NO: 1 OF 2

STG: R

REV: 15

N/P: -

Mouser Electronics

Authorized Distributor

Click to View Pricing, Inventory, Delivery & Lifecycle Information:

[Aptiv:](#)

[13783284-L](#)