

REV.	DATE	ECR NO.	DESCRIPTION
A	04/28/97	-	CHANGE GOLD PLATING SPEC.
B	09/30/08	-	UPDATE DRAWING FORMAT.

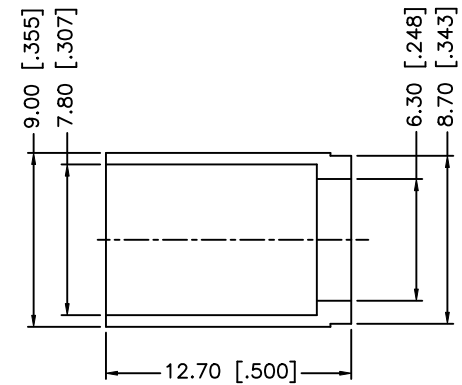
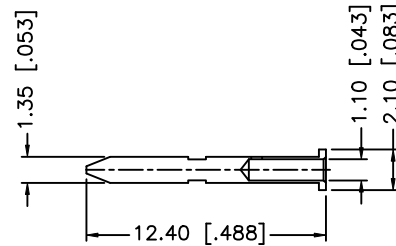
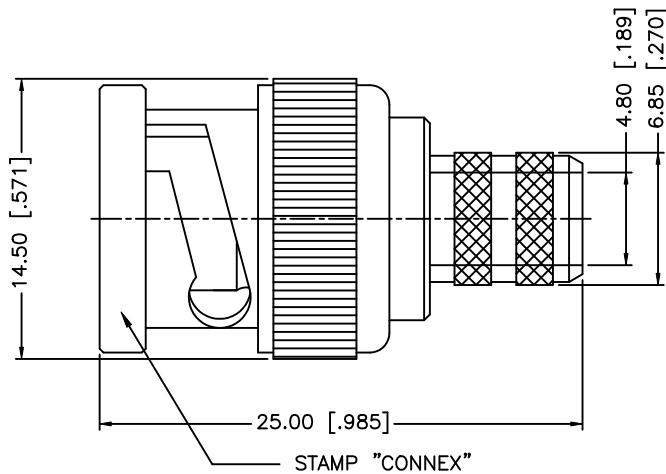
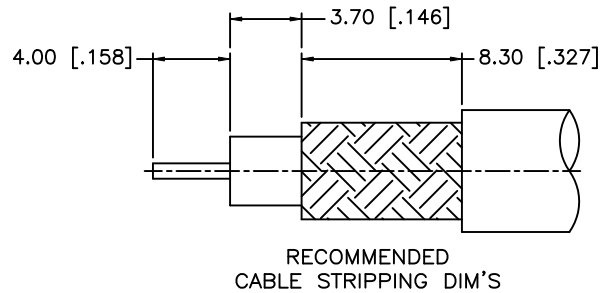

NOTES: FINISH (PLATING THICKNESS IN MICRO-INCHES)

1. NICKEL PL. 100 MIN. OVER COPPER PL. 50 MIN.
2. GOLD PL. 15 MIN. OVER NICKEL PL. 50 MIN. OVER COPPER PL. 50 MIN.
3. TEFLON MIL-P-19468.

8				
7				
6				
5				
4	FERRULE	BRASS	NICKEL	1
3	CONTACT PIN	BRASS	GOLD	1
2	INSULATOR	PTFE	NATURAL	1
1	BODY	BRASS	NICKEL	1
	DESCRIPTION	MATERIAL	FINISH	QTY

UNLESS OTHERWISE SPECIFIED DIMENSIONS ARE IN MILLIMETERS. DIMENSIONS IN [] ARE IN INCHES AND FOR CUSTOMER REFERENCE ONLY.

UNLESS OTHERWISE SPECIFIED TOLERANCES FOR MILLIMETERS ARE:
0.5 - 8mm ± 0.20mm
8 - 30mm ± 0.40mm
30 - 120mm ± 0.50mm

UNLESS OTHERWISE SPECIFIED TOLERANCES FOR INCHES ARE:
.020 - .315 ± 0.007"
.315 - 1.180 ± 0.015"
1.180 - 4.724 ± 0.020"

DO NOT SCALE DRAWING

APPROVALS	DATE
DRAWN GRS	09/30/08
CHECKED	
ISSUED	
SHEET 1 OF 1	
CAD FILE	C:/112/112958.DWG

<h1>Amphenol Connex</h1>			
PART DESCRIPTION BNC CRIMP PLUG (RG-6 PLENUM/ BELDEN 1695A - 75 ohms)			
PART NO. 112958			
DWG. NO.	112958.DWG	REV. B	SIZE A
			SCALE NA

Mouser Electronics

Authorized Distributor

Click to View Pricing, Inventory, Delivery & Lifecycle Information:

[Amphenol:](#)

[112958](#)