

## Panel mounting frames - VC-AR2/3M - 1852985

Please be informed that the data shown in this PDF Document is generated from our Online Catalog. Please find the complete data in the user's documentation. Our General Terms of Use for Downloads are valid (<http://phoenixcontact.com/download>)



Panel mounting frame, without PE, for contact insert modules, type 2, number of insert modules 3

Panel mounting frame, size VC-2

### Product Features

- Compact design
- Universal connection
- Proven COMBICON technology
- Can be keyed to prevent incorrect connection



### Key Commercial Data

Packing unit	1 pc
Minimum order quantity	5 pc
GTIN	 4 017918 134341
Weight per Piece (excluding packing)	12.29 g
Custom tariff number	85389099
Country of origin	Poland

### Technical data

#### General

Note	2 x 1852862 VC-AF for each connector
Size	VC2

#### Ambient conditions

Ambient temperature (operation)	-40 °C ... 125 °C
---------------------------------	-------------------

#### Material data

## Panel mounting frames - VC-AR2/3M - 1852985

### Technical data

#### Material data

Flammability rating according to UL 94	V0
--	----

#### Standards and Regulations

Flammability rating according to UL 94	V0
--	----

### Classifications

#### eCl@ss

eCl@ss 4.0	27140816
eCl@ss 4.1	27140816
eCl@ss 5.0	27371205
eCl@ss 5.1	27371205
eCl@ss 6.0	27371205
eCl@ss 7.0	27371205
eCl@ss 8.0	27440210
eCl@ss 9.0	27440210

#### ETIM

ETIM 2.0	EC000437
ETIM 3.0	EC000437
ETIM 4.0	EC000437
ETIM 5.0	EC002310

#### UNSPSC

UNSPSC 6.01	31261501
UNSPSC 7.0901	31261501
UNSPSC 11	31261501
UNSPSC 12.01	31261501
UNSPSC 13.2	31261501

### Approvals

#### Approvals

---

Approvals

EAC

---

# Panel mounting frames - VC-AR2/3M - 1852985

## Approvals

Ex Approvals

---

Approvals submitted

---

Approval details

EAC
-----

## Accessories

Accessories

Panel mounting flange

Mounting flange - VC-AF - 1852862



Panel mounting flange for screw locking, for mounting contact insert modules, for a panel thickness of 1 - 5 mm

---

## Drawings

Dimensional drawing

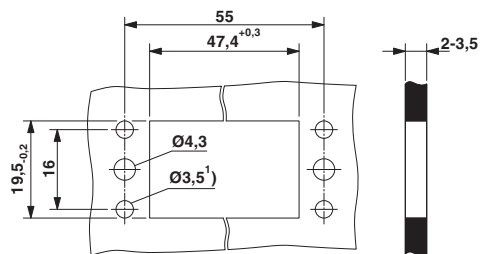

Housing cutout

## Panel mounting frames - VC-AR2/3M - 1852985

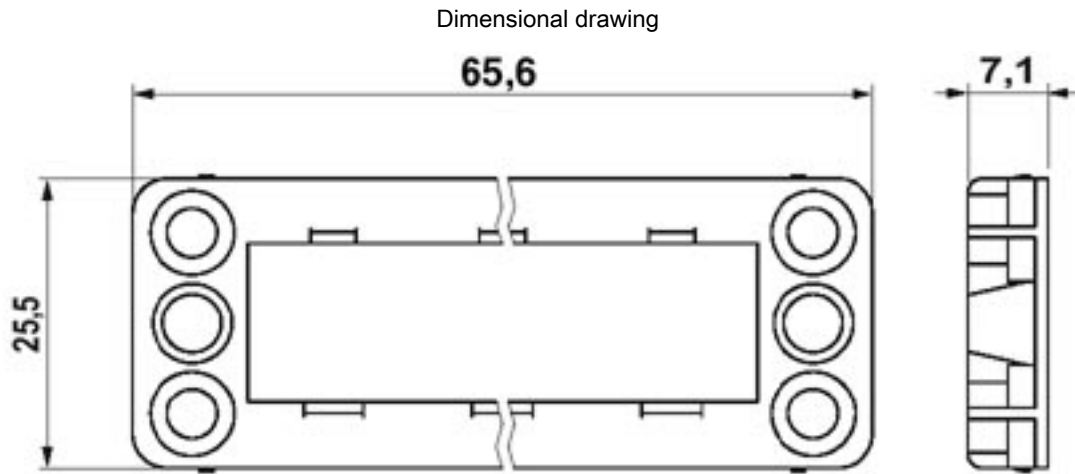

Panel mounting frame dimensional drawing

## Panel mounting frames - VC-AR2/3M - 1852985

Dimensional drawing

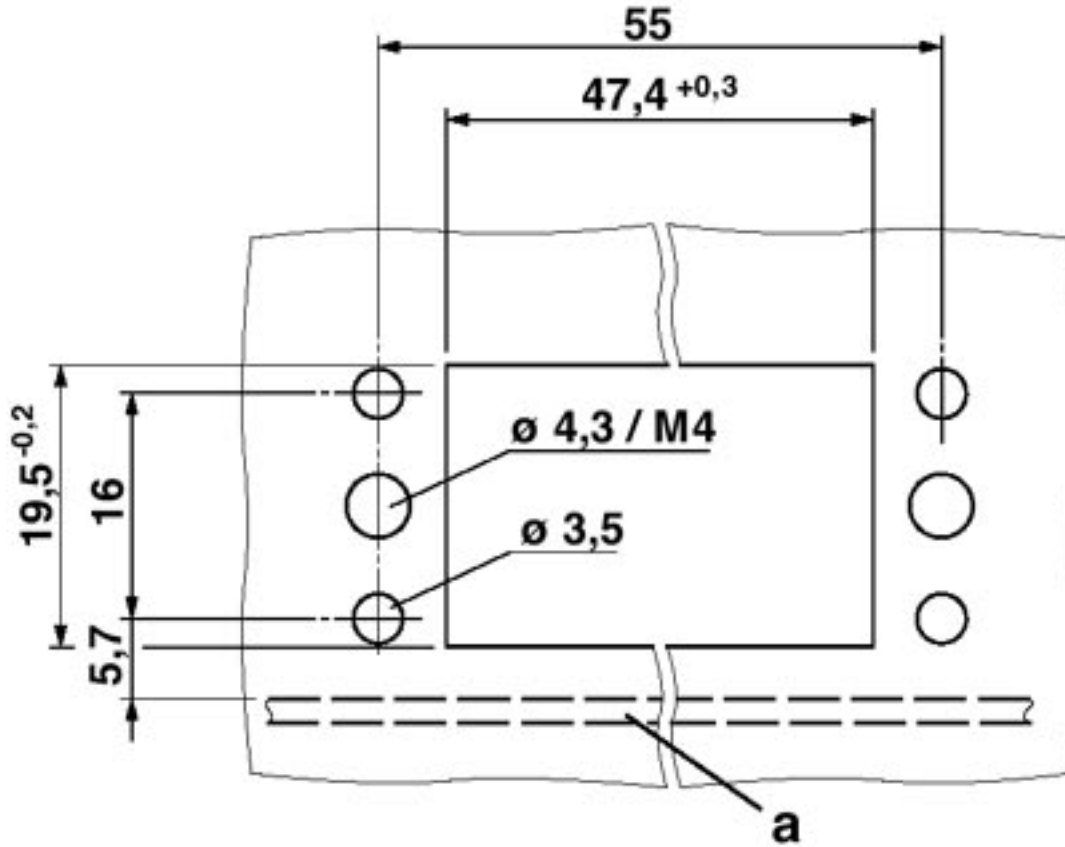

a - PCB

# Mouser Electronics

Authorized Distributor

Click to View Pricing, Inventory, Delivery & Lifecycle Information:

[Phoenix Contact:](#)

[1852985](#)