

**NOTES:**

MATERIAL: BRASS  
 PLATING: 10u" GOLD OVER 50u" NICKEL  
 NICKEL ON WIRE CRIMP AREA  
 WIRE SIZE: 24-26 AWG

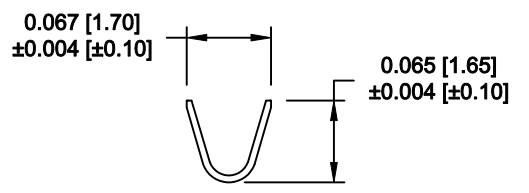

SECTION A - A

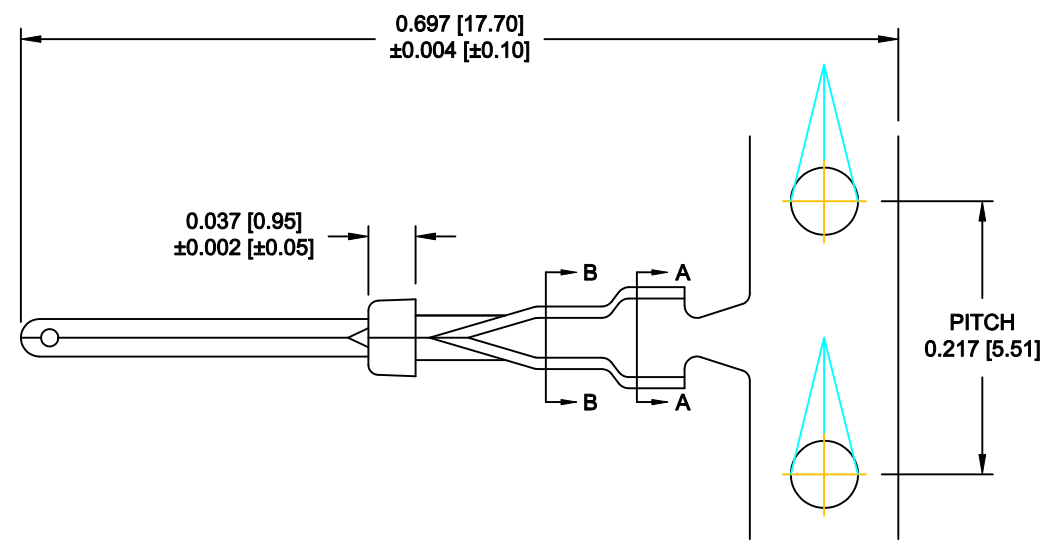
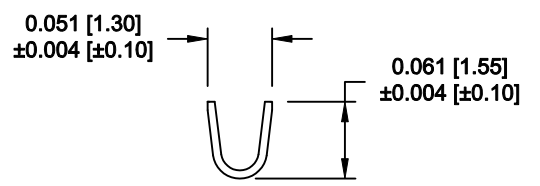
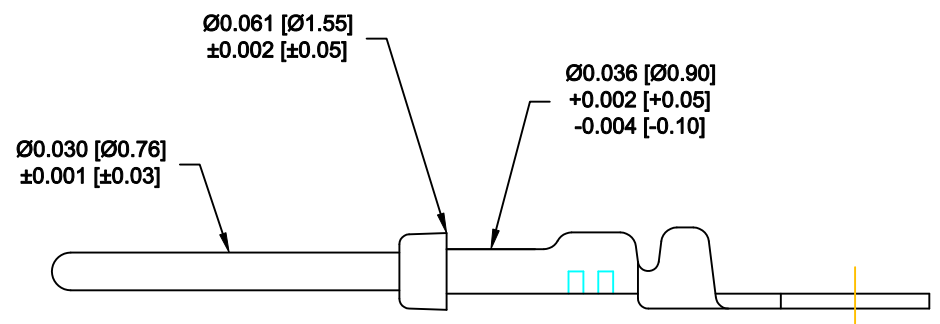

SECTION B - B

FOR CLARITY  
 HIDDEN LINES  
 NOT SHOWN

DO NOT SCALE FROM DRAWING

RoHS COMPLIANT

	THESE DRAWINGS AND SPECIFICATIONS ARE THE PROPERTY OF NorComp AND SHALL NOT BE REPRODUCED, COPIED OR USED AS THE BASIS FOR THE MANUFACTURE OF SALE OF APPARATUS WITHOUT WRITTEN PERMISSION.		DRAWN: <b>PAM JENKINS</b>	DATE: <b>02-13-09</b>
			CHECKED:	DATE:
<b>NorComp</b>		SCALE: <b>6 : 1</b>	SHEET <b>1</b> OF <b>2</b>	REV <b>6</b>
		DWG NO. <b>180-001-170L001</b>		

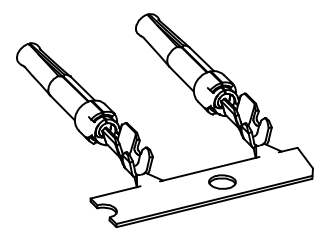
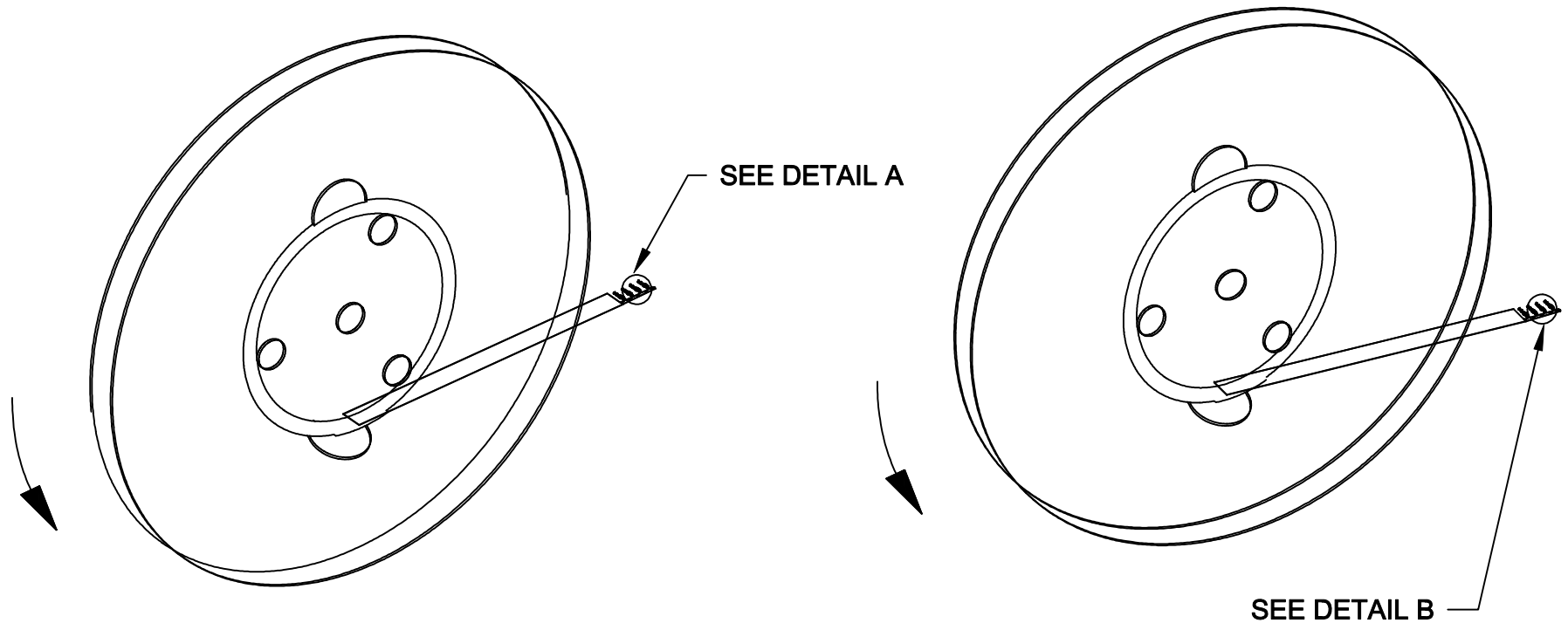

DETAIL A

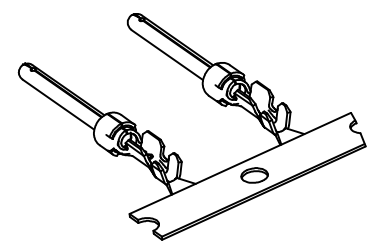

DETAIL B

	THESE DRAWINGS AND SPECIFICATIONS ARE THE PROPERTY OF NorComp AND SHALL NOT BE REPRODUCED, COPIED OR USED AS THE BASIS FOR THE MANUFACTURE OF SALE OF APPARATUS WITHOUT WRITTEN PERMISSION.		DRAWN: PAM JENKINS	DATE: 02-13-09
			CHECKED:	DATE:
<h1>NorComp</h1>		SCALE:	SHEET 2 OF 2	REV 6
		DWG NO. 180-001-170L001		

# Mouser Electronics

Authorized Distributor

Click to View Pricing, Inventory, Delivery & Lifecycle Information:

[NorComp:](#)

[180-001-170L001](#)