

DRAWING MADE IN THIRD ANGLE PROJECTION

LOC FT DIST 22

REVISIONS					
P	F	LTR	DESCRIPTION	DATE	APPROVED
✓		G1	REDRAWN W/O CHANGE	ADO895	9/12/85 CP
✓		H	REV PER EC 0320-349-97	20 NOV 97	NS

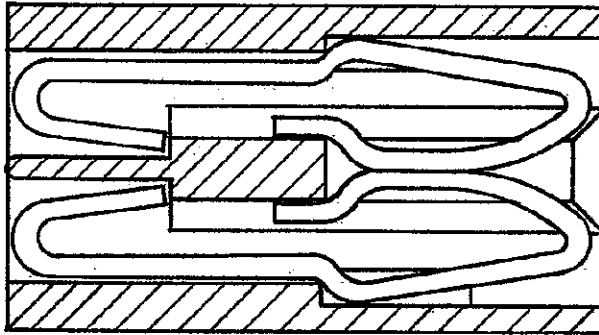

DIRECTION OF INSERTION IS FROM CARD SLOT SIDE

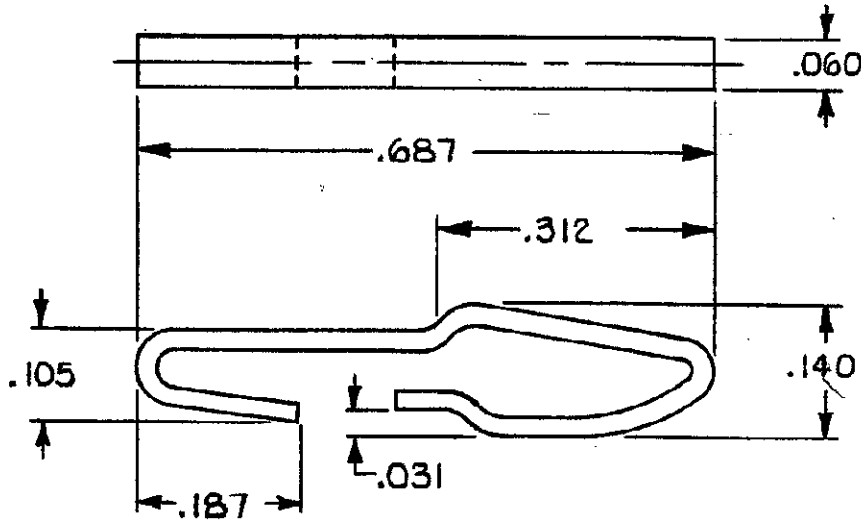

.000030 GOLD OVER NICKEL	42973-3
UNPLATED	42973-2
NICKEL .000050 THICK	42973-1
FINISH	PART NO

THIS DRAWING IS UNPUBLISHED. RELEASED FOR PUBLICATION  
 BY AMP INCORPORATED, HARRISBURG, PA. ALL INTERNATIONAL RIGHTS RESERVED. AMP PRODUCTS MAY BE COVERED BY U.S. AND FOREIGN PATENTS AND/OR PATENTS PENDING.

UNLESS OTHERWISE SPECIFIED DIMENSIONS ARE IN INCHES. TOLERANCES ON: DECIMALS ±.015 ANGLES ±	CONTRACT NO
	DR <i>Craig Pierce 9-13-85</i>
MATERIAL STAINLESS STEEL 301 .020 THK.	CHK <i>H.W. Rosa 9/16/85</i>
	APPD <i>Howard W. Rosa 9/16/85</i>
FINISH SEE TABLE	DSGN APPD
	OTHER APPD

<b>AMP</b>   AMP INCORPORATED Harrisburg, Pa. 17105		
NAME SPRING, RETAINING, AMP LEAF		
SIZE <b>A</b>	FSCM NO <b>00779</b>	DRAWING NO <b>42973</b>
SCALE 5:1	SHEET 1 OF 1	

# Mouser Electronics

Authorized Distributor

Click to View Pricing, Inventory, Delivery & Lifecycle Information:

[TE Connectivity:](#)

[42973-2](#)