

## D-SUB sleeve housings - VS-25-T-2M20 - 1689792

Please be informed that the data shown in this PDF Document is generated from our Online Catalog. Please find the complete data in the user's documentation. Our General Terms of Use for Downloads are valid (<http://phoenixcontact.com/download>)



D-SUB sleeve housing, shell size 3, IP67 degree of protection



### Key Commercial Data

Packing unit	1 pc
Minimum order quantity	5 pc
Weight per Piece (excluding packing)	46.72 g
Custom tariff number	85472000
Country of origin	Germany

### Technical data

#### Mechanical characteristics

Insertion/withdrawal cycles	≥ 1000
External cable diameter	5 mm ... 13 mm
Cable exit	Angled
Color	gray

#### Ambient conditions

Ambient temperature (operation)	-40 °C ... 80 °C
---------------------------------	------------------

#### Material data

Flammability rating according to UL 94	V0
Housing material	PA

#### Electrical characteristics

Degree of pollution	2
---------------------	---

#### Standards and Regulations

# D-SUB sleeve housings - VS-25-T-2M20 - 1689792

## Technical data

### Standards and Regulations

Flammability rating according to UL 94	V0
--	----

## Classifications

### eCl@ss

eCl@ss 4.0	27140816
eCl@ss 4.1	27260701
eCl@ss 5.0	27260701
eCl@ss 5.1	27260701
eCl@ss 6.0	27261203
eCl@ss 7.0	27440202
eCl@ss 8.0	27440202
eCl@ss 9.0	27440202

### ETIM

ETIM 2.0	EC000437
ETIM 3.0	EC000437
ETIM 4.0	EC000437
ETIM 5.0	EC000437

### UNSPSC

UNSPSC 6.01	31261501
UNSPSC 7.0901	31261501
UNSPSC 11	31261501
UNSPSC 12.01	31261501
UNSPSC 13.2	31261501

## Approvals

### Approvals

---

Approvals

EAC

---

Ex Approvals

---

## D-SUB sleeve housings - VS-25-T-2M20 - 1689792

### Approvals

Approvals submitted

---

### Approval details

EAC

---

### Accessories

Accessories

Coding element

Coding profile - CP-HCC 4 - 1600027



Coding profile, Number of positions: 1, Color: red

---

### Device marking

Zack marker strip - ZBN 18:UNBEDRUCKT - 2809128



Zack marker strip, Strip, white, unlabeled, can be labeled with: Plotter, Mounting type: Snap into tall marker groove, for terminal block width: 18 mm, Lettering field: 18 x 5 mm

---

### Pressure nut

D-SUB pressure nut - VS-M20 (5-13) - 1652127



D-SUB cap nut with line seal, for conductor diameter of 5 mm ... 13 mm, for sleeve housing VS-25-...

---

### Protective cap

## D-SUB sleeve housings - VS-25-T-2M20 - 1689792

### Accessories

Filler plugs - Q-PROT 9/11 - 1670235



Closing cap for Pg9/Pg11 to close unoccupied connections

---

### Shroud

D-SUB EMC inner sleeve - VS-25-TI-2 EMV - 1689802



D-SUB EMC inner sleeve, shell size 3, for sleeve housing VS-25-...

---

### Drawings

Dimensional drawing

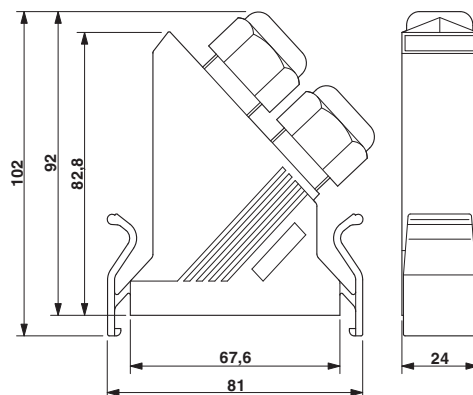

D-SUB sleeve housings

# Mouser Electronics

Authorized Distributor

Click to View Pricing, Inventory, Delivery & Lifecycle Information:

[Phoenix Contact:](#)

[1689792](#)