



40x40x20 mm

San Ace 40 9GA type Low Power Consumption Fan

General Specifications

- Material Frame: Plastic (Flammability: UL 94V-0), Impeller: Plastic (Flammability: UL 94V-0)
- Expected life See the table below. (L10 life: 90% survival rate for continuous operation in free air at 60°C, rated voltage)
- Motor protection function Locked rotor burnout protection, Reverse polarity protection
For details, please refer to p. 529.
- Dielectric strength 50/60 Hz, 500 VAC, for 1 minute (between lead wire conductors and frame)
- Insulation resistance 10 MΩ or more with a 500 VDC megger (between lead wire conductors and frame)
- Sound pressure level (SPL) At 1 m away from the air inlet
- Storage temperature -30 to +70°C (Non-condensing)
- Lead wire ⊕Red ⊖Black (Sensor) Yellow (Control) Brown
- Mass 35 g

Specifications

The models listed below **have ribs and pulse sensors with PWM control function.**

Model no.	Rated voltage [V]	Operating voltage range [V]	PWM duty cycle* [%]	Rated current [A]	Rated input [W]	Rated speed [min ⁻¹]	Max. airflow [m ³ /min] [CFM]	Max. static pressure [Pa] [inchH ₂ O]	SPL [dB (A)]	Operating temperature [°C]	Expected life [h]
9GA0405P6H001**	5	4.5 to 5.5	100	0.35	1.75	12400	0.33 11.7	191 0.77	40	-20 to +70	40000/60°C
9GA0405P6F001**			100	0.18	0.9	8000	0.21 7.4	79.5 0.32	28		60000/60°C
9GA0412P6G001	12	10.2 to 13.8	100	0.23	2.76	16000	0.42 14.8	318 1.28	47		40000/60°C
			0	0.04	0.48	3800	0.1 3.5	17.9 0.07	14		60000/60°C
9GA0412P6H001			100	0.14	1.68	12400	0.33 11.7	191 0.77	40		
0			0.04	0.48	3800	0.1 3.5	17.9 0.07	14			
9GA0412P6F001			100	0.08	0.96	8000	0.21 7.4	79.5 0.32	28		
0			0.03	0.36	2200	0.06 2.1	6.0 0.02	10			
9GA0424P6G001**	24	20.4 to 27.6	100	0.13	3.12	16000	0.42 14.8	318 1.28	47		40000/60°C
9GA0424P6H001**			100	0.08	1.92	12400	0.33 11.7	191 0.77	40		60000/60°C
9GA0424P6F001**			100	0.04	0.96	8000	0.21 7.4	79.5 0.32	28		

* PWM frequency: 25 kHz ** Fan does not rotate when PWM duty cycle is 0%.

Other sensor specifications are available as options. Refer to the index (p. 551).

Airflow - Static Pressure Characteristics / PWM Duty - Speed Characteristics Example

9GA0405P6H001 With pulse sensor with PWM control function

PWM duty cycle

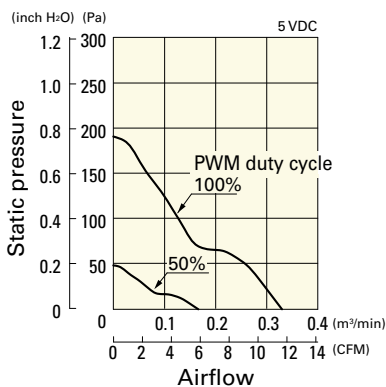

Operating voltage range

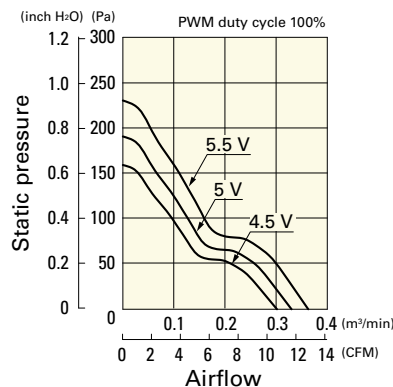

PWM duty - Speed characteristics example

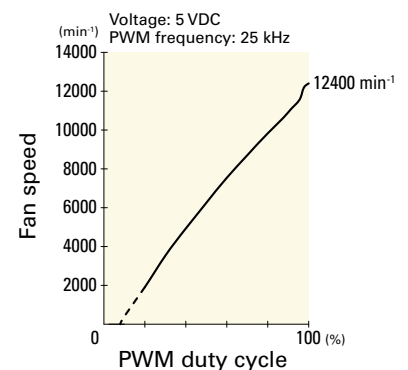

Airflow - Static Pressure Characteristics / PWM Duty - Speed Characteristics Example

9GA0405P6F001 With pulse sensor with PWM control function

PWM duty cycle

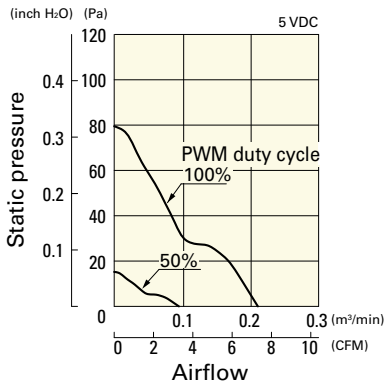

Operating voltage range

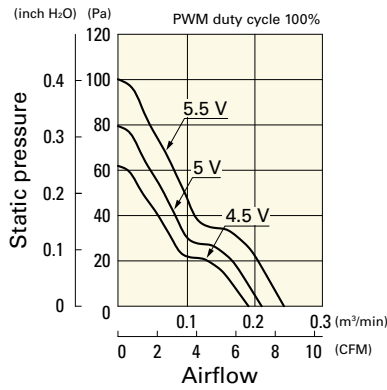

PWM duty - Speed characteristics example

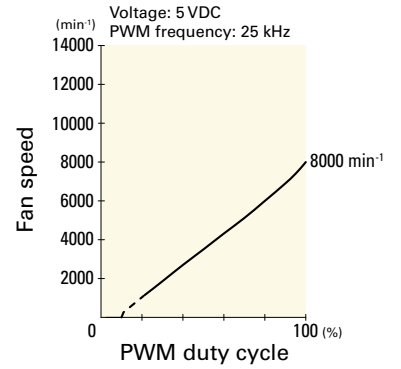

9GA0412P6G001 With pulse sensor with PWM control function

PWM duty cycle

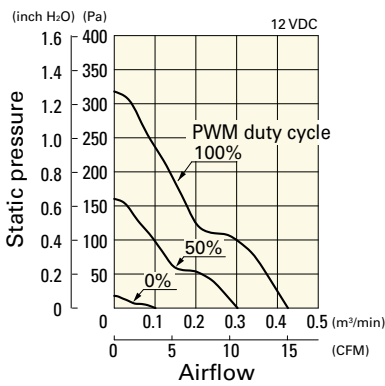

Operating voltage range

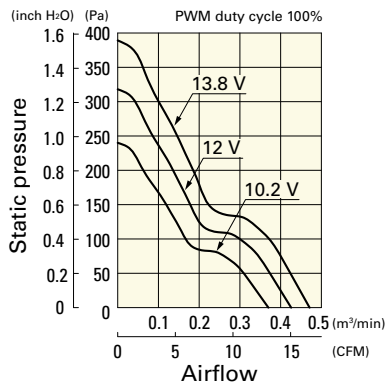

PWM duty - Speed characteristics example

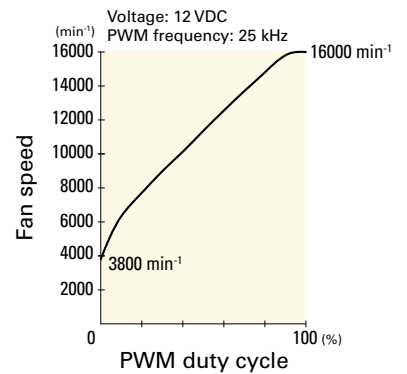

9GA0412P6H001 With pulse sensor with PWM control function

PWM duty cycle

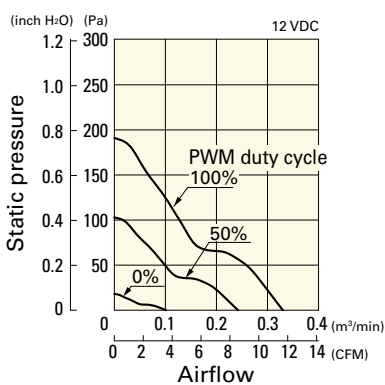

Operating voltage range

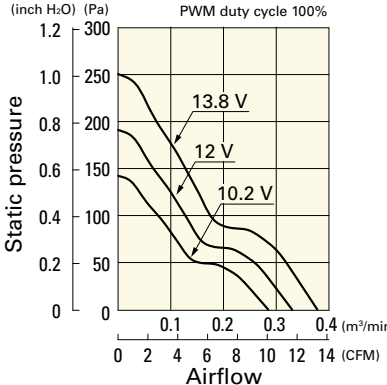

PWM duty - Speed characteristics example

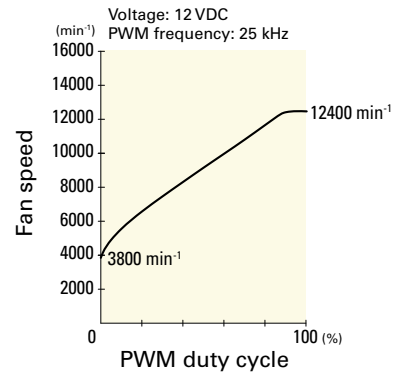

9GA0412P6F001 With pulse sensor with PWM control function

PWM duty cycle

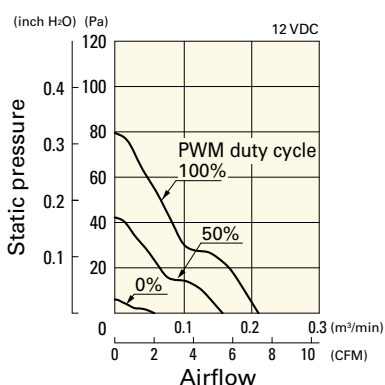

Operating voltage range

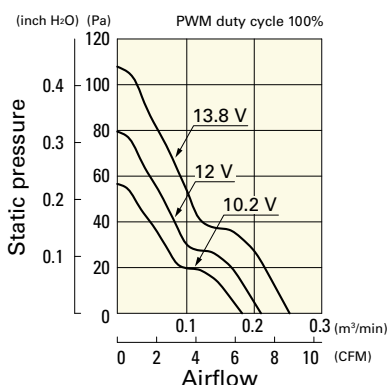

PWM duty - Speed characteristics example

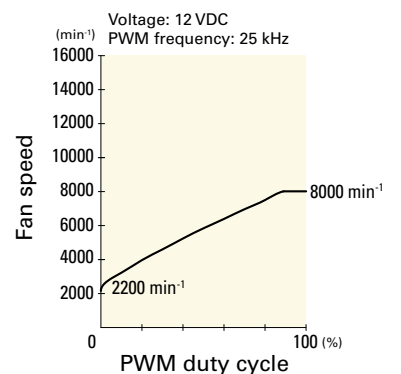

Airflow - Static Pressure Characteristics / PWM Duty - Speed Characteristics Example

9GA0424P6G001 With pulse sensor with PWM control function

PWM duty cycle

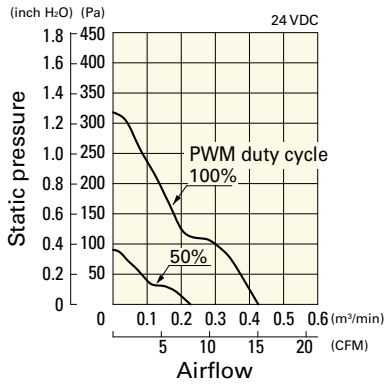

Operating voltage range

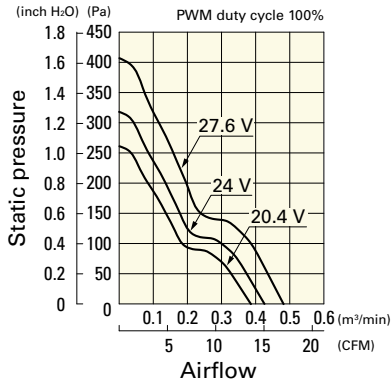

PWM duty - Speed characteristics example

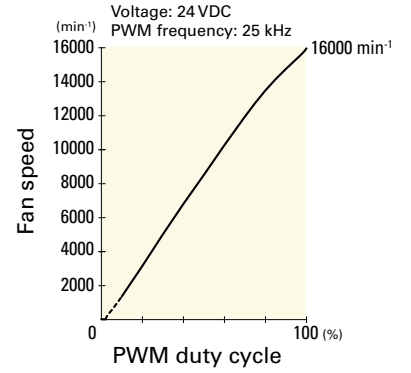

9GA0424P6H001 With pulse sensor with PWM control function

PWM duty cycle

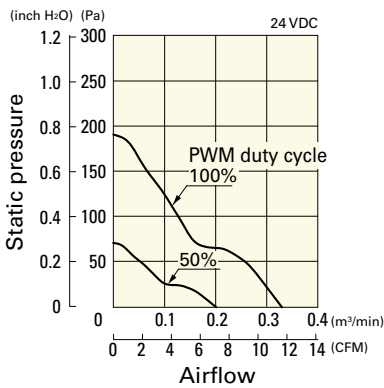

Operating voltage range

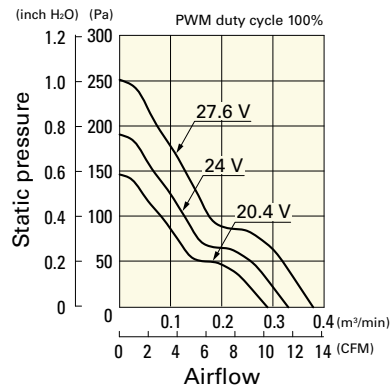

PWM duty - Speed characteristics example

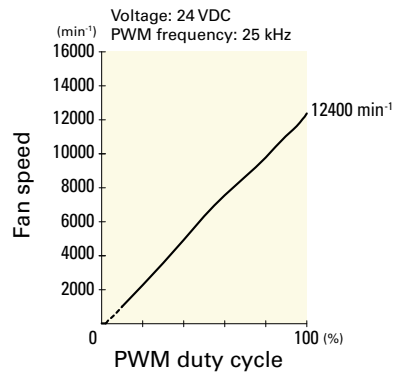

9GA0424P6F001 With pulse sensor with PWM control function

PWM duty cycle

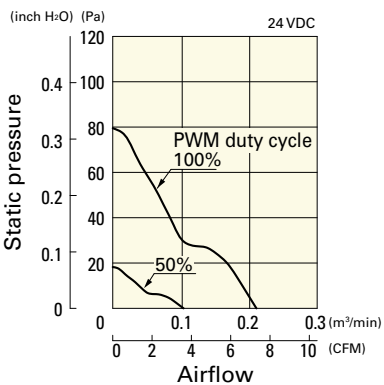

Operating voltage range

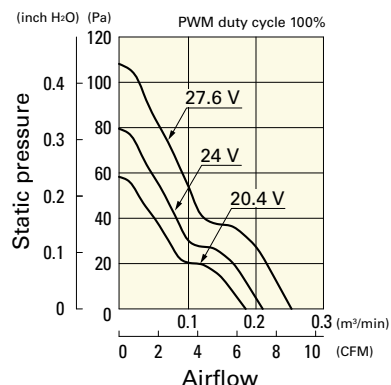

PWM duty - Speed characteristics example

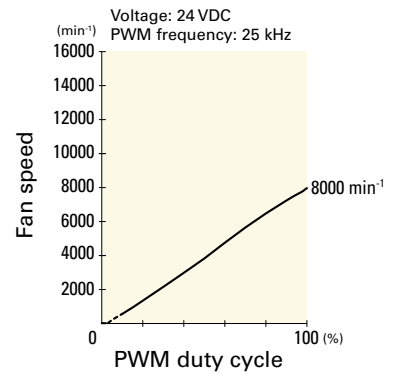

Dimensions (unit: mm)

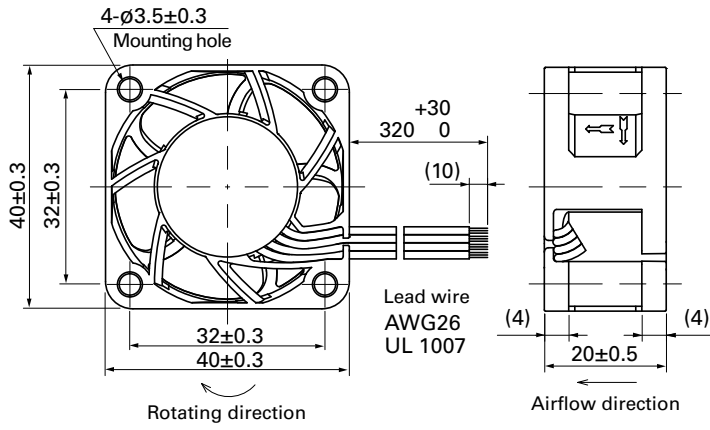

Reference Dimensions of Mounting Holes and Vent Opening (unit: mm)

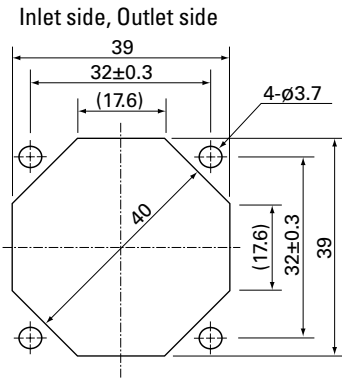

Options

Finger guards

page: p. 513

Model no.: 109-059, 109-059H

Mouser Electronics

Authorized Distributor

Click to View Pricing, Inventory, Delivery & Lifecycle Information:

Sanyo Denki:

[9GA0412P6G001](#) [9GA0412P6H001](#) [9GA0424P6F001](#) [9GA0424P6H001](#) [9GA0405P6H001](#) [9GA0405P6F001](#)
[9GA0412P6F001](#) [9GA0412F6001](#) [9GA0424P6G001](#) [9GA0424H6001](#) [9GA0412G6001](#) [9GA0424G6D001](#)
[9GA0405F6001](#) [9GA0405F6002](#) [9GA0405H6001](#) [9GA0405H6002](#) [9GA0412H6002](#) [9GA0412F6002](#) [9GA0424F6001](#)
[9GA0424F6002](#) [9GA0424G6001](#) [9GA0424G6002](#) [9GA0412G6002](#) [9GA0412H6001](#) [9GA0424H6002](#)
[9GA0424H6D001](#)