

NCP2824

Non-Clip and Power Limit Mono Class D Amplifier with AGC

Description

The NCP2824 is a Filterless Class D amplifier capable of delivering up to 2.4 W to a 4 Ω load with a 5 V supply voltage. With the same battery voltage, it can deliver 1.2 W to an 8 Ω load with less than 1% THD+N. The non-clipping function automatically adjusts the output voltage in order to control the distortion when an excessive input is applied to the amplifier. This adjustment is done thanks to an Automatic Gain Control circuitry (AGC) built into the chip. A simple Single wire interface allows to the non Clipping function to be enabled and disabled. It also allows the maximum distortion level in the output to be configured. A programmable power limit function is also embedded in order to protect speakers from damage caused by an excessive sound level.

Features

- Non Clipping Function with Automatic Gain Control Circuitry
- Programmable Power Limit Function
- Single Wire Interface. No Need for Additional Components
- Max THD+N Configurable by Swire Interface
- Only One Capacitor Required
- Fully Differential Architecture: Better RF Immunity
- No Need for Input Capacitors in Fully Differential Configuration
- High Efficiency: up to 90%
- Low Quiescent Current: 2.2 mA Typ
- Large Output Power Capability
- High PSRR: up to -80 dB
- Fully Differential Capability: RF Immunity
- Thermal and Auto Recovery Short-Circuit Protection
- CMRR (-80 dB) Eliminates Two Input Coupling Capacitors
- Pb-Free and Halide-Free Device

Typical Applications

Audio Amplifier for:

- Cellular Phones
- Digital Cameras
- Personal Digital Assistant and Portable Media Player
- GPS

Demo Board Available:

- The NCP2824GEVB/D evaluation board configures the device in typical application.



ON Semiconductor®

<http://onsemi.com>



9 PIN FLIP-CHIP
FC SUFFIX
CASE 499AL

PIN CONFIGURATION

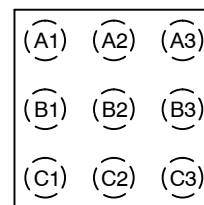

(Top View)

A1 = INP B1 = AGND C1 = INM
A2 = VDD B2 = NC C2 = CNTL
A3 = OUTP B3 = PGND C3 = OUTM

MARKING DIAGRAM

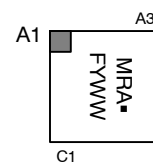

MRA = Specific Device Code
F = Assembly Location
Y = Year
WW = Work Week
G or ■ = Pb-Free Package

ORDERING INFORMATION

Device	Package	Shipping†
NCP2824FCT2G	WCSP-9 (Pb-Free)	3000/Tape & Reel

†For information on tape and reel specifications, including part orientation and tape sizes, please refer to our Tape and Reel Packaging Specification Brochure, BRD8011/D.

NCP2824

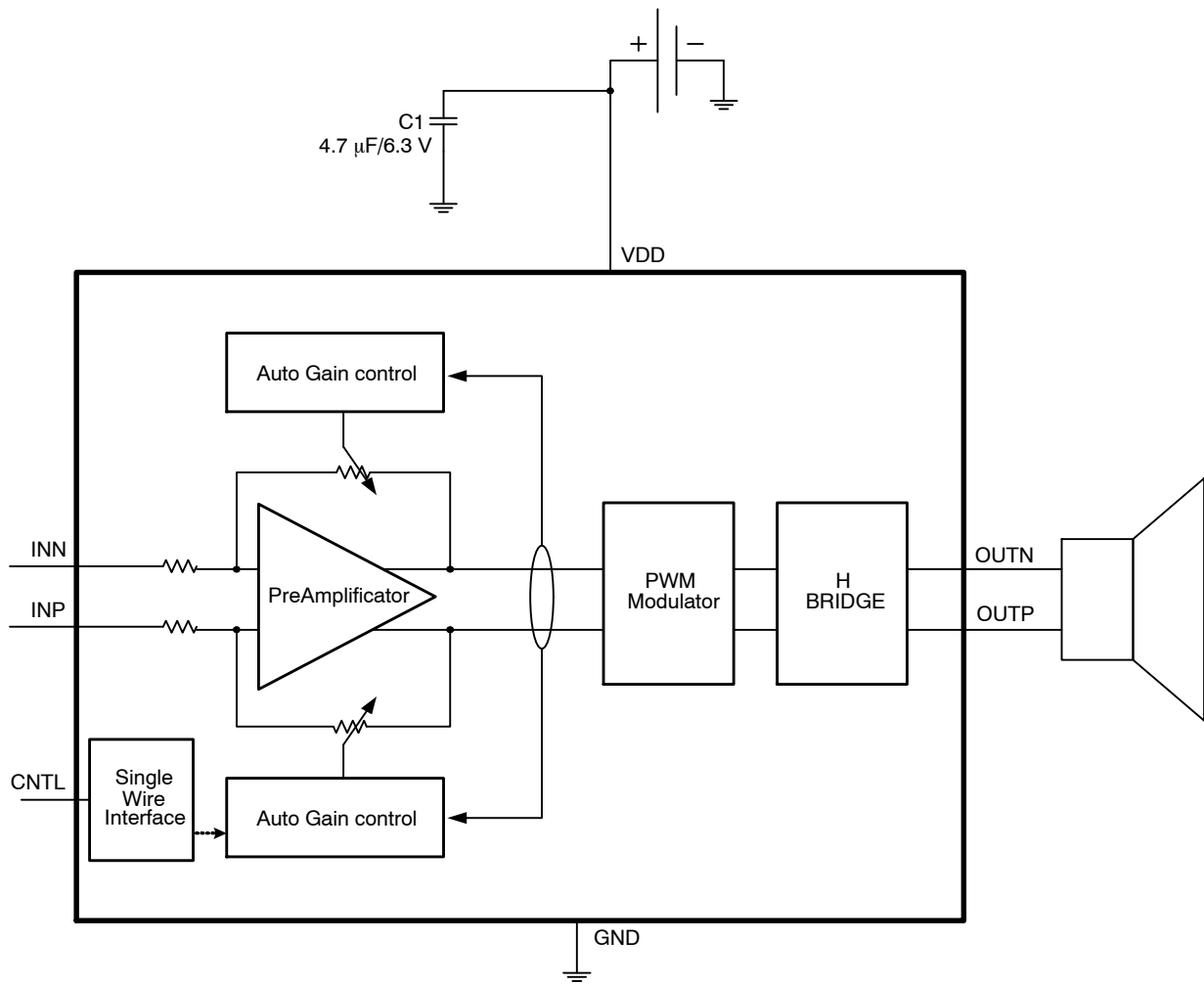

Figure 1. Simplified Block Diagram

Table 1. PIN FUNCTION DESCRIPTION

Pin	Pin Name	Type	Description
A1	INP	Input	Positive Input
C1	INN	Input	Negative Input
A2	PVDD	POWER	Power Supply: This pin is the power supply of the device. A 4.7 μF ceramic capacitor or larger must bypass this input to the ground. This capacitor should be placed as close as possible to this input.
B2	NC	–	Non-connected: reserved for production. Must be kept floating in the final application
A3	OUTP	Output	Positive output: Special care must be observed at layout level. See the Layout consideration section
C3	OUTN	Output	Negative output: Special care must be observed at layout level. See the Layout consideration section
C2	CNTL	Input	Control: This pin is dedicated to the control of the chip via the Single wire protocol
B3	PGND	POWER	Power Ground: This pin is the power ground and carries the high switching current. A high quality ground must be provided to avoid any noise spikes/uncontrolled operation. Care must be observed to avoid high-density current flow in a limited PCB copper track.
B1	AGND	POWER	Analog Ground: This pin is the analog ground of the device and must be connected to GND plane.

Table 2. MAXIMUM RATINGS

Rating	Symbol	Value	Unit
AVDD, PVDD Pins: Power Supply Voltage (Note 2)	V _{DD}	–0.3 to +6.0	V
INP/N Pins: Input (Note 2)	V _{INP/N}	–0.3 to +V _{DD}	V
Digital Input/Output: EN Pin: Input Voltage Input Current	V _{DG} I _{DG}	–0.3 to V _{DD} + 0.3 1	V mA
Human Body Model (HBM) ESD Rating are (Note 3)	ESD HBM	2000	V
Machine Model (MM) ESD Rating are (Note 3)	ESD MM	200	V
WCSP 1.5 x 1.5 mm package (Notes 6 and 7) Thermal Resistance Junction to Case	R _{θJC}	90	°C/W
Operating Ambient Temperature Range	T _A	–40 to +85	°C
Operating Junction Temperature Range	T _J	–40 to +125	°C
Maximum Junction Temperature (Note 6)	T _{JMAX}	+150	°C
Storage Temperature Range	T _{STG}	–65 to +150	°C
Moisture Sensitivity (Note 5)	MSL	Level 1	

Stresses exceeding Maximum Ratings may damage the device. Maximum Ratings are stress ratings only. Functional operation above the Recommended Operating Conditions is not implied. Extended exposure to stresses above the Recommended Operating Conditions may affect device reliability.

1. Maximum electrical ratings are defined as those values beyond which damage to the device may occur at T_A = 25°C.
2. According to JEDEC standard JESD22–A108B.
3. This device series contains ESD protection and passes the following tests:
Human Body Model (HBM) ±2.0 kV per JEDEC standard: JESD22–A114 for all pins.
Machine Model (MM) ±200 V per JEDEC standard: JESD22–A115 for all pins.
4. Latch up Current Maximum Rating: ±100 mA per JEDEC standard: JESD78 class II.
5. Moisture Sensitivity Level (MSL): 1 per IPC/JEDEC standard: J–STD–020A.
6. The thermal shutdown set to 150°C (typical) avoids irreversible damage on the device due to power dissipation.
7. The R_{θCA} is dependent on the PCB heat dissipation. The maximum power dissipation (P_D) is dependent on the min input voltage, the max output current and external components selected.

$$R_{\theta CA} = \frac{125 - T_A}{P_D} - R_{\theta JC}$$

NCP2824

Table 3. ELECTRICAL CHARACTERISTICS (Min & Max Limits apply for T_A between -40°C to $+85^{\circ}\text{C}$ and for V_{DD} between 2.5 V to 5.5 V (Unless otherwise noted). Typical values are referenced to $T_A = +25^{\circ}\text{C}$ and $V_{DD} = 3.6\text{ V}$. (see Note 8))

Symbol	Parameter	Conditions	Min	Typ	Max	Unit
GENERAL PERFORMANCES						
V_{DD}	Operational Power Supply		2.5		5.5	V
F_{OSC}	Oscillator Frequency		250	300	350	kHz
I_{dd}	Supply current	$V_{DD} = 3.6\text{ V}$, No Load $V_{DD} = 5.5\text{ V}$, No Load, $T_A = 85^{\circ}\text{C}$		2.2	4.2	mA
I_{sd}	Shutdown current	$V_{DD} = 3.6\text{ V}$, $V_{CNTL} = 0\text{ V}$ $V_{DD} = 5.5\text{ V}$, $V_{CNTL} = 0\text{ V}$, $T_A = 85^{\circ}\text{C}$		0.01	1	μA
T_{ON}	Turn ON Time	Single Wire Activation		7.4		ms
T_{OFF}	Turn Off Time	Single Wire Deactivation		5		ms
Z_{sd}	Class D Output impedance in shutdown mode	$V_{ENL} = 0\text{ V}$		20		k Ω
$R_{DS(ON)}$	Static drain-source on-state resistance of power Mosfets			250		m Ω
η	Efficiency	$V_{DD} = 3.6\text{ V}$, $P_o = 800\text{ mW}$, $R_L = 8\ \Omega$, $F = 1\text{ kHz}$		86		%
		$V_{DD} = 3.6\text{ V}$, $P_o = 1.3\text{ W}$, $R_L = 4\ \Omega$, $F = 1\text{ kHz}$		79		
F_{LP}	-3 dB Cut off Frequency of the Built in Low Pass Filter			30		kHz
T_{SD}	Thermal Shut Down Protection			150		$^{\circ}\text{C}$
T_{SDH}	Thermal Shut Down Hysteresis			20		$^{\circ}\text{C}$

AGC SECTION

A_v	Voltage gain	Single Wire 4		12		dB
A_v	Voltage gain	Single Wire 5		18		dB
A_a	Max AGC attenuation			-15		dB
A_{vn}	AGC Gain step resolution			0.5		dB
T_A	Attack time			0.033		ms/Step
T_R	Release Time			0.013		s/Step
T_H	Hold Time			0.013		s/Step

S-WIRE INTERFACE (see Note 9)

V_{IH}	Rising Voltage Input Logic High		1.2	-	5.5	V
V_{IL}	Falling Voltage Input Logics Low		0	-	0.4	V
V_{IHYS}	Input Voltage Hysteresis			100		mV
R_{PLD}	Pull Down Resistor			20		k Ω
T_R	Swire Rising time				200	ns
T_F	Swire Falling time				200	ns
T_{SWH}	Swire High		5	10	45	μs
T_{SWL}	Swire Low		5	10	75	μs

8. Performances guaranteed over the indicated operating temperature range by design and/or characterization, production tested at $T_J = T_A = 25^{\circ}\text{C}$.

9. Single Wire performances is guaranteed by design and characterized

10. Audio performances are given for $V_{dd} = 3.6\text{ V}$, $T_A = 25^{\circ}\text{C}$ and characterized

NCP2824

Table 3. ELECTRICAL CHARACTERISTICS (Min & Max Limits apply for T_A between -40°C to $+85^{\circ}\text{C}$ and for V_{DD} between 2.5 V to 5.5 V (Unless otherwise noted). Typical values are referenced to $T_A = +25^{\circ}\text{C}$ and $V_{DD} = 3.6\text{ V}$. (see Note 8))

Symbol	Parameter	Conditions	Min	Typ	Max	Unit
S-WIRE INTERFACE (see Note 9)						
F_{SWF}	Input S-wire Frequency				100	kHz
T_{EHDT}	Enable High Delay Time		0		400	μs
T_{SDD}	Time to Shunt Down Delay		300		400	μs
$T_{WAKE-UP}$	Time to Wake up from shutdown				500	μs
T_{VALID}	Time to Valid Data		300		400	μs
AUDIO PERFORMANCES (see Note 10)						
V_{oo}	Output offset	$A_v = 12\text{ dB}$		0.3		mV
$PSRR_{DC}$	Power supply rejection ratio	From $V_{DD} = 2.5\text{ V}$ to 5.5 V		-80		dB
$PSRR_{AC}$	Power supply rejection ratio	$F = 217\text{ Hz}$, Input ac grounded, $A_v = 12\text{ dB}$		-70		dB
		$F = 1\text{ kHz}$, Input ac grounded $A_v = 12\text{ dB}$		-70		
SNR	Signal to noise ratio	$V_p = 5\text{ V}$, $P_{out} = 600\text{ mW}$ (A. Weighted) $A_v = 12\text{ dB}$		96		dB
CMRR	Common mode rejection ratio	Input shorted together $V_{IC} = 1\text{ V}_{pp}$, $f = 217\text{ Hz}$		-80		dB
V_n	Output Voltage noise	Input ac grounded, $A_v = 12\text{ dB}$ $20\text{ Hz} < f < 20\text{ kHz}$ A. Weighted		34		μV
P_o	Output Power	$R_L = 8\ \Omega$ $F = 1\text{ kHz}$	THD+N<1%	$V_{DD} = 5\text{ V}$	1.2	W
				$V_{DD} = 3.6\text{ V}$	0.6	
				$V_{DD} = 2.5\text{ V}$	0.22	
		THD+N<10%	$V_{DD} = 5\text{ V}$	1.5		
			$V_{DD} = 3.6\text{ V}$	0.8		
			$V_{DD} = 2.5\text{ V}$	0.4		
		$R_L = 4\ \Omega$ $F = 1\text{ kHz}$	THD+N<1%	$V_{DD} = 5\text{ V}$	2	
				$V_{DD} = 3.6\text{ V}$	1	
				$V_{DD} = 2.5\text{ V}$	0.4	
				THD+N<10%	$V_{DD} = 5\text{ V}$	
$V_{DD} = 3.6\text{ V}$	1.3					
$V_{DD} = 2.5\text{ V}$	0.6					
THD+N	Total harmonic distortion plus noise	$V_{DD} = 3.6\text{ V}$, $P_o = 0.5\text{ W}$		0.06		%
		$V_{DD} = 5\text{ V}$, $P_o = 1\text{ W}$		0.09		

8. Performances guaranteed over the indicated operating temperature range by design and/or characterization, production tested at $T_J = T_A = 25^{\circ}\text{C}$.

9. Single Wire performances is guaranteed by design and characterized

10. Audio performances are given for $V_{dd} = 3.6\text{ V}$, $T_A = 25^{\circ}\text{C}$ and characterized

NCP2824

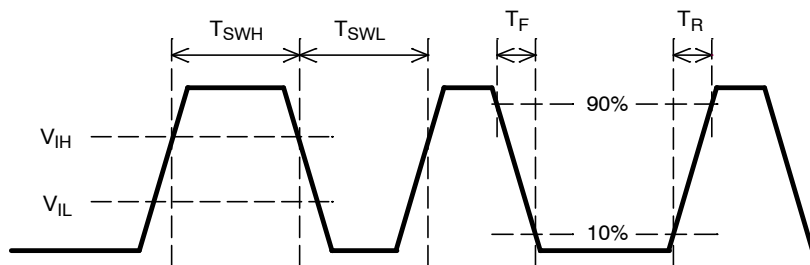

Figure 2. S-Wire Logic Diagram

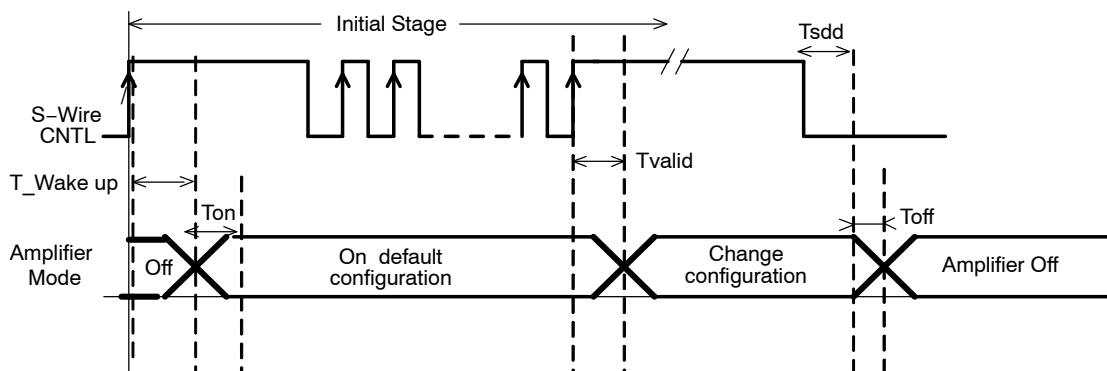

Figure 3. S-Wire / Enable Timing Diagram

TYPICAL OPERATING CHARACTERISTICS

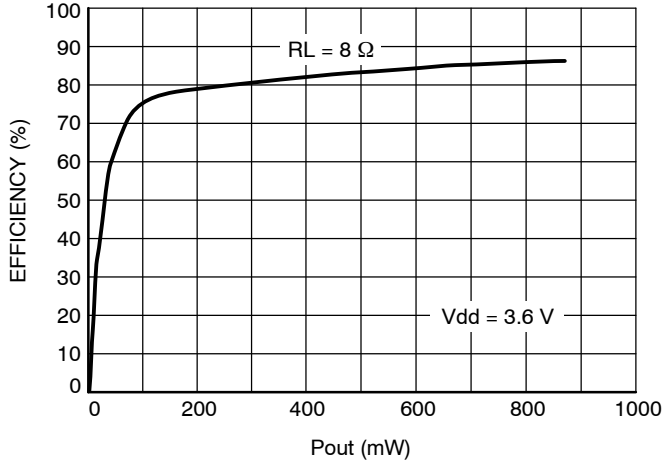

Figure 4. Efficiency vs. Pout

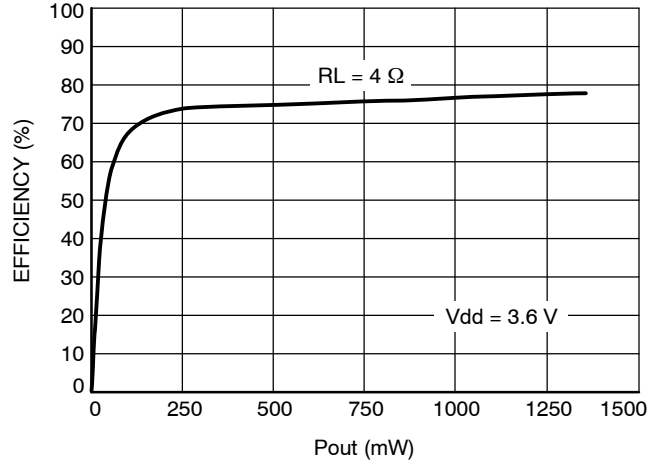

Figure 5. Efficiency vs. Pout

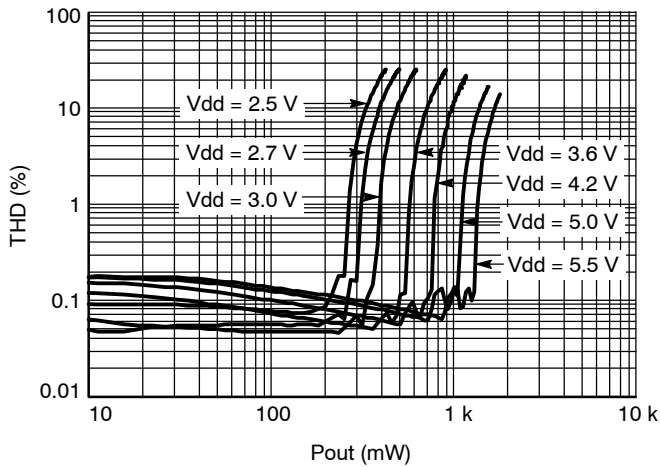

Figure 6. THD+N vs. Pout, RL = 8 Ω

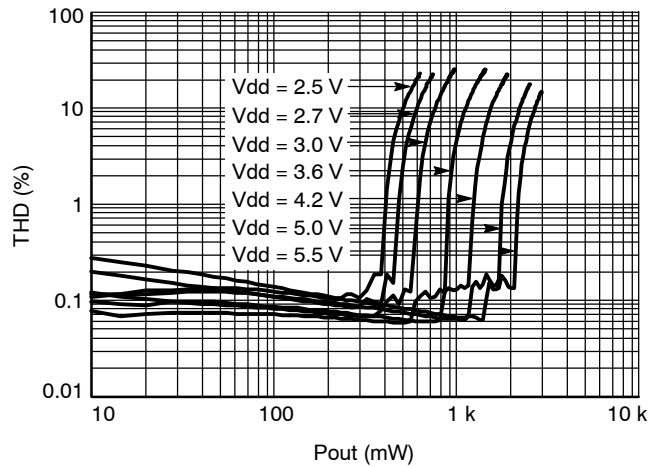

Figure 7. THD+N vs. Pout, RL = 4 Ω

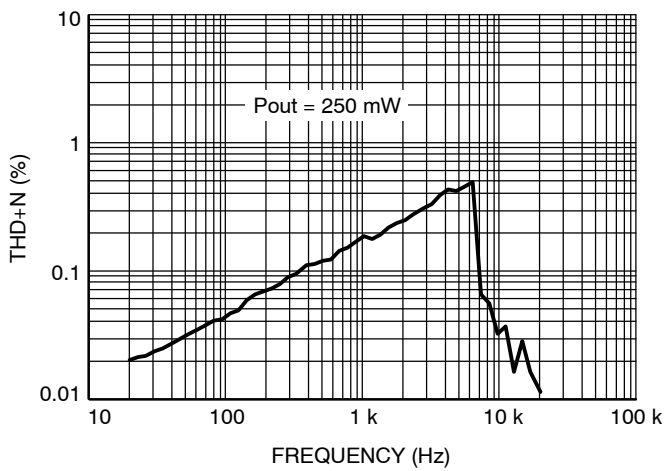

Figure 8. THD+N vs. Frequency, Vdd = 2.5 V

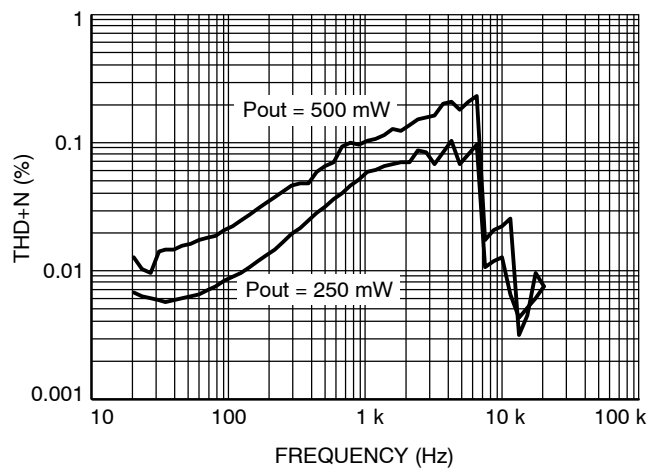

Figure 9. THD+N vs. Frequency, Vdd = 3.6 V

TYPICAL OPERATING CHARACTERISTICS

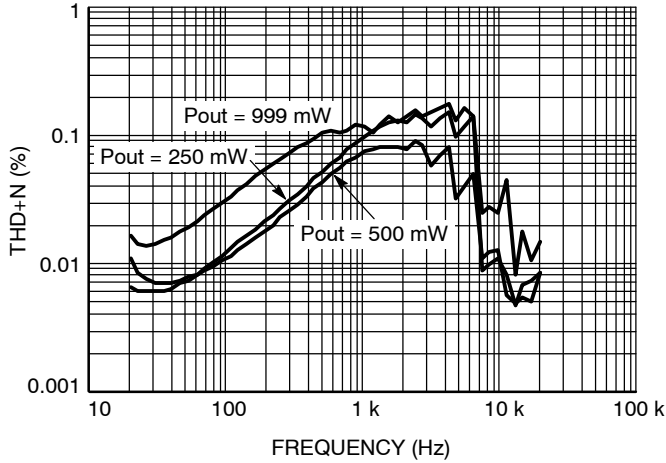

Figure 10. THD+N vs. Frequency, Vdd = 5 V

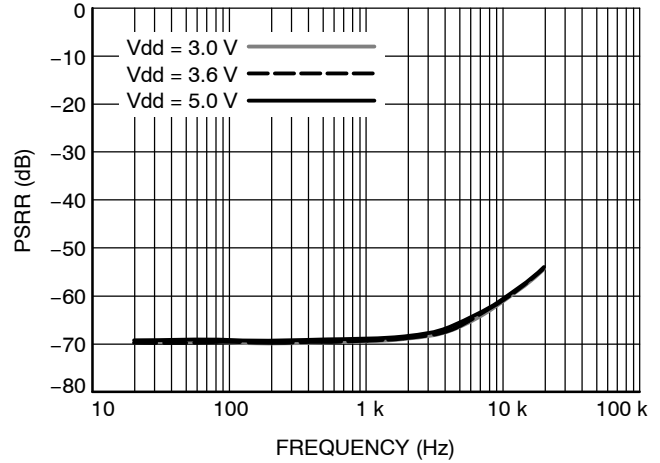

Figure 11. PSRR vs. Frequency
(Inputs Grounded, Gain = 12 dB, Cin = 1 μF)

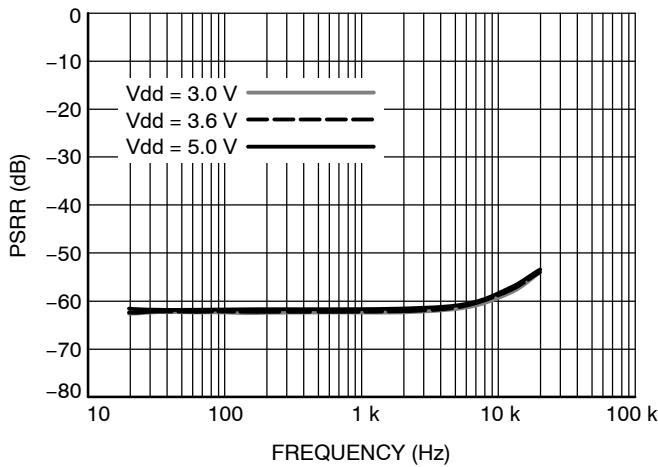

Figure 12. PSRR vs. Frequency
(Inputs Grounded, Gain = 18 dB, Cin = 1 μF)

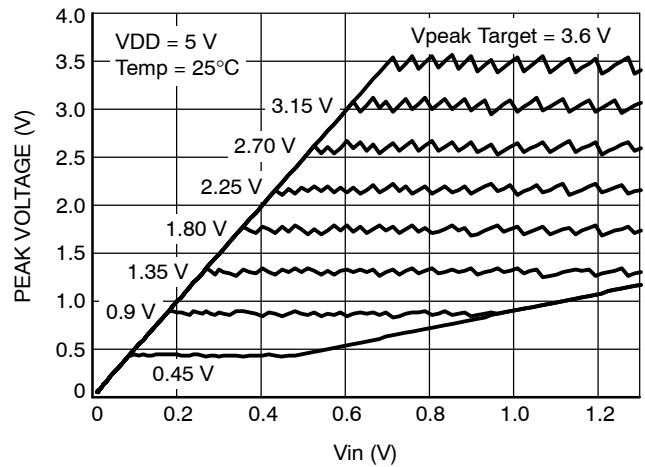

Figure 13. Peak Output Voltage in Power Limit
vs. Input Voltage (rms) and Power Limit
Settings, Av = 12 dB

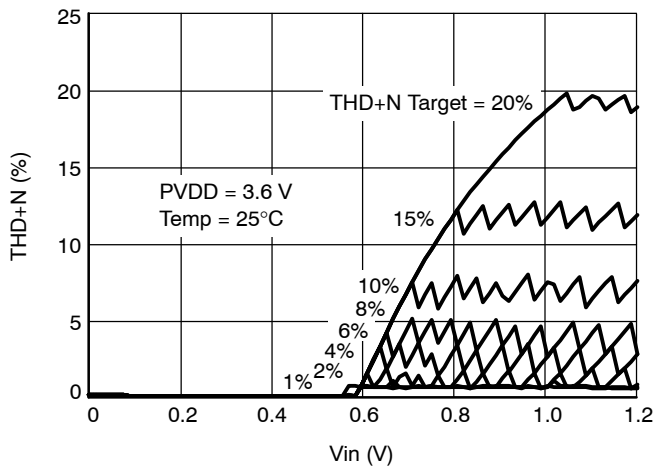

Figure 14. THD+N vs. Input Voltage (rms) and
Non Clip Settings, RL = 8 Ω, Av = 12 dB

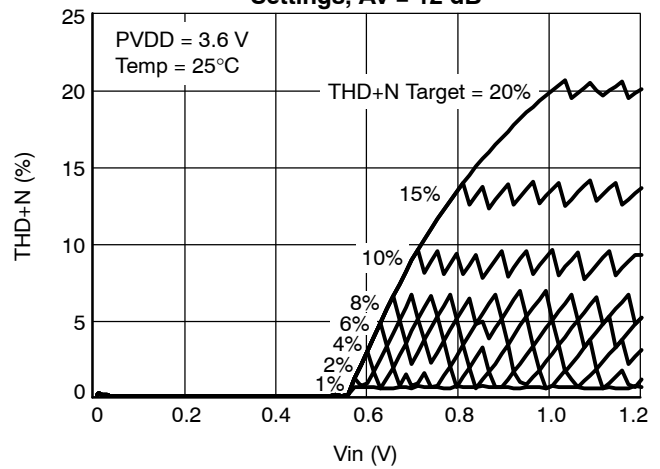

Figure 15. THD+N vs. Input Voltage (rms) and
Non Clip Settings, RL = 4 Ω, Av = 12 dB

Detailed Operating Description

General Description

The NCP2824 is a Mono class D audio amplifier featuring a preamplifier stage, a PWM stage and an H-Bridge stage with an automatic Gain control circuitry which performs the non clipping function.

Non Clipping Function

In the presence of an exceeded input signal, when the audio signal is going to be clipped, the gain of the audio amplifier automatically decreases as defined by the AGC operation. The maximum level of THD is programmable and can be set by a final user through the single wire interface (see table n°1).

At the same time, the battery voltage is continuously monitored. The output signal is adapted to the dynamic battery voltage (Vdd) in order to avoid distortion due to supply voltage fluctuation like GSM burst.

This function solution allows the chip to maximize the sound pressure level while maintaining a controlled THD level.

The following picture depicts the non clipping operation.

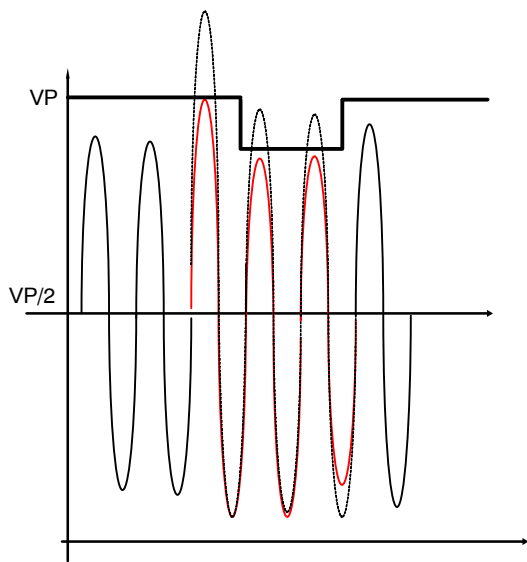

Figure 16. Output of the Amplifier during a Line Transient on the Battery Voltage

Power Limit Function: Speaker Protection

In addition to the non clipping function, a Power limit function is embedded in the NCP2824 in order to protect speakers from excessive output signal levels. When the output signal exceed this limit, the ???

Thus, the final user can use the Single Wire interface to program the maximum voltage rated by the speaker or to disable this power limit protection.

AGC Operation

The AGC operation defines the timings when the non clipping function is engaged.

The typical values are described in the Electrical Table (“AGC Section”).

Attack time (Ta): is defined as the minimum time between two gain decrease.

Hold time (Th): is defined as the minimum time between a gain increase after a gain decrease.

Release time (Tr): is defined as the minimum time between two gain increase.

The following pictures depict the NCP2824 non clipping operation.

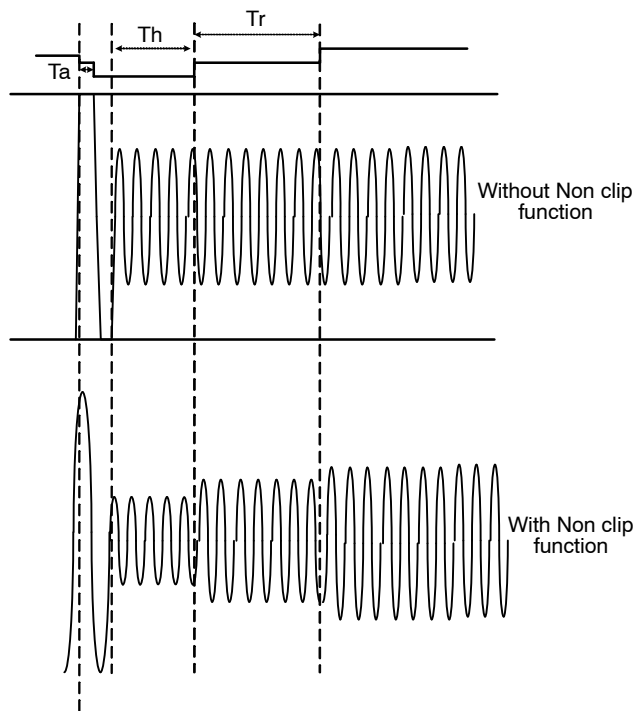

Single Wire Interface Operation

The single wire interface allows changing the default configuration of the NCP2824.

After Wake up, the NCP2824 is configured with:

- AGC enable
- Non Clip + Power limit
- Gain = 18 dB
- THD max = 1%

The following table described all the NCP2824 configurations.

Table 4. NCP2824 CONFIGURATION

Pulse Counting	Register	Description
01	AGC	AGC disable
02		AGC Enable
03	Reset	Reset configuration
04	Gain Control	Gain = 12 dB
05		Gain = 18 dB
06	THD Control	1%
07		2%
08		4%
09		6%
10		8%
11		10%
12		15%
13		20%
14	NC+L	Non Clip + Power limit
15	NC	Non Clip only
16	Power Limit Control	0.45 V _{Peak}
17		0.9 V _{Peak}
18		1.35 V _{Peak}
19		1.8 V _{Peak}
20		2.25 V _{Peak}
21		2.7 V _{Peak}
22		3.15 V _{Peak}
23		3.6 V _{Peak}

NOTE: The given values are typical for V_{dd} = 3.6 V and T_A = 25°C characterized

Built-in Low Pass Filter

This filter allows the user to connect a DAC or a CODEC directly to the NCP2824 input without increasing the output noise by mixing frequency with the DAC/CODEC output frequency. Consequently, optimized operation with DACs or CODECs is guaranteed without additional external components.

Decoupling Capacitors

The NCP2824 requires a correct decoupling of the power supply in order to guarantee the best operation in terms of audio performances. To achieve optimum performance, it is necessary to place a 4.7 μF low ESR ceramic capacitor as close as possible to the VDD pin in order to reduce high frequency transient spikes due to parasitic inductance (see Layout considerations).

Input Capacitors C_{in}

Thanks to its fully differential architecture, the NCP2824 does not require input capacitors. However, it is possible to

use input capacitors when the differential source is not biased or in single ended configuration. In this case it is necessary to take into account the corner frequency which can influence the low frequency response of the NCP2824. The following equation will help choose the adequate input capacitor.

$$f_c = \frac{1}{2 \cdot \pi \cdot 75 \cdot 10^3 \cdot C_{in}}$$

Over Current Protection

This protection allows an over current in the H-Bridge to be detected. When the current is higher than 2 A, the H-Bridge is positioned in high impedance. When the short circuit is removed or the current is lower, the NCP2824 goes back to normal operation. This protection avoids over current due to a bad assembly (Output shorted together, to V_{dd} or to ground).

Layout Recommendations

For Efficiency and EMI considerations, it is strongly recommended to use Power and ground plane in order to reduce parasitic resistance and inductance.

For the same reason, it is recommended to keep the output traces short and well shielded in order to avoid them to act as antenna.

The level of EMI is strongly dependent upon the application. However, ferrite beads placed close to the NCP2824 will reduce EMI radiation when it is needed.

Ferrite value is strongly dependent upon the application.

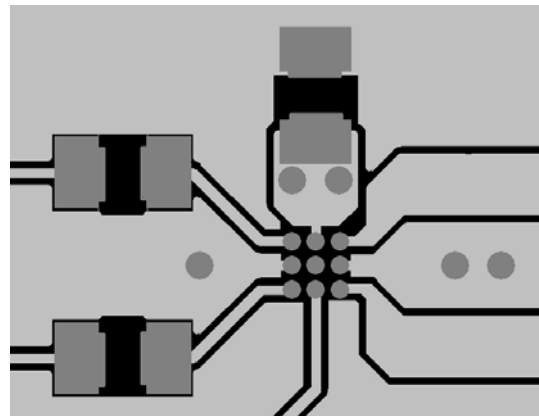

Figure 17. Example of PCB Layout

Components Selection

To achieve optimum performance, one 4.7 μF 6.3 V X5R should be used to bypass the power input supply (VDD).

Also particular care must be observed for DC-bias effects in the ceramic capacitor selection. Smaller case-size and higher DC bias voltage is preferred.

Some recommended capacitors include but are not limited to:

4.7 μF 6.3 V 0603

TDK: C1608X5R0J475MT 0.95 mm max.

NCP2824

Example of Application Schematic

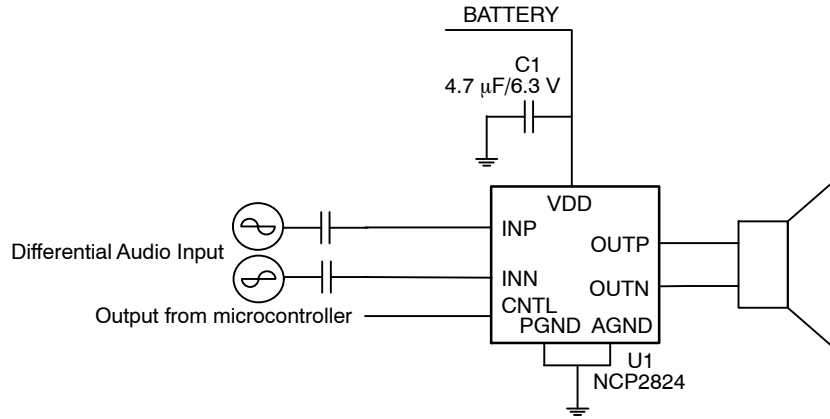

Figure 18. Differential Configuration

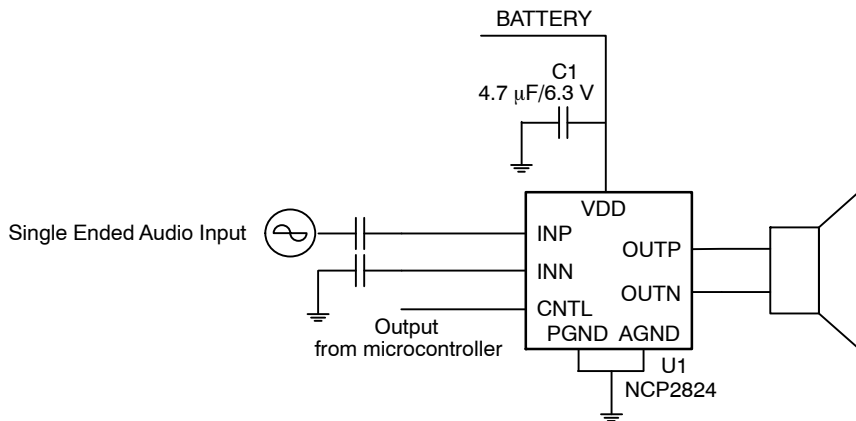
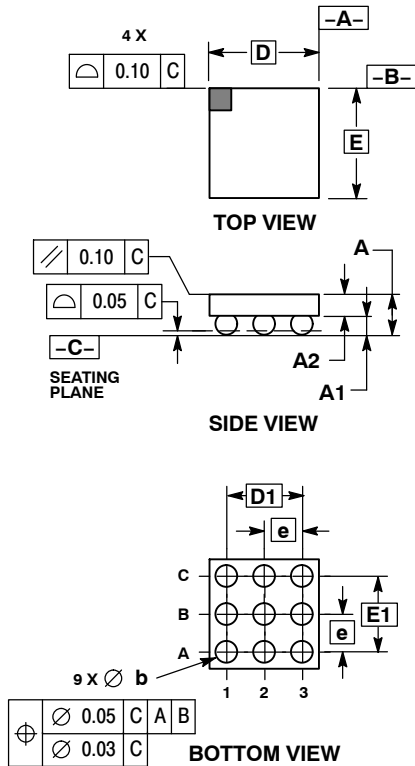

Figure 19. Single Ended Configuration

NCP2824

PACKAGE DIMENSIONS

9 PIN FLIP-CHIP
CASE 499AL-01
ISSUE O



NOTES:

1. DIMENSIONING AND TOLERANCING PER ANSI Y14.5M, 1982.
2. CONTROLLING DIMENSION: MILLIMETERS.
3. COPLANARITY APPLIES TO SPHERICAL CROWNS OF SOLDER BALLS.

DIM	MILLIMETERS	
	MIN	MAX
A	0.540	0.660
A1	0.210	0.270
A2	0.330	0.390
D	1.450 BSC	
E	1.450 BSC	
b	0.290	0.340
e	0.500 BSC	
D1	1.000 BSC	
E1	1.000 BSC	

ON Semiconductor and are registered trademarks of Semiconductor Components Industries, LLC (SCILLC). SCILLC reserves the right to make changes without further notice to any products herein. SCILLC makes no warranty, representation or guarantee regarding the suitability of its products for any particular purpose, nor does SCILLC assume any liability arising out of the application or use of any product or circuit, and specifically disclaims any and all liability, including without limitation special, consequential or incidental damages. "Typical" parameters which may be provided in SCILLC data sheets and/or specifications can and do vary in different applications and actual performance may vary over time. All operating parameters, including "Typicals" must be validated for each customer application by customer's technical experts. SCILLC does not convey any license under its patent rights nor the rights of others. SCILLC products are not designed, intended, or authorized for use as components in systems intended for surgical implant into the body, or other applications intended to support or sustain life, or for any other application in which the failure of the SCILLC product could create a situation where personal injury or death may occur. Should Buyer purchase or use SCILLC products for any such unintended or unauthorized application, Buyer shall indemnify and hold SCILLC and its officers, employees, subsidiaries, affiliates, and distributors harmless against all claims, costs, damages, and expenses, and reasonable attorney fees arising out of, directly or indirectly, any claim of personal injury or death associated with such unintended or unauthorized use, even if such claim alleges that SCILLC was negligent regarding the design or manufacture of the part. SCILLC is an Equal Opportunity/Affirmative Action Employer. This literature is subject to all applicable copyright laws and is not for resale in any manner.

PUBLICATION ORDERING INFORMATION

LITERATURE FULFILLMENT:
Literature Distribution Center for ON Semiconductor
P.O. Box 5163, Denver, Colorado 80217 USA
Phone: 303-675-2175 or 800-344-3860 Toll Free USA/Canada
Fax: 303-675-2176 or 800-344-3867 Toll Free USA/Canada
Email: orderlit@onsemi.com

N. American Technical Support: 800-282-9855 Toll Free
USA/Canada
Europe, Middle East and Africa Technical Support:
Phone: 421 33 790 2910
Japan Customer Focus Center
Phone: 81-3-5773-3850

ON Semiconductor Website: www.onsemi.com

Order Literature: <http://www.onsemi.com/orderlit>

For additional information, please contact your local Sales Representative

Mouser Electronics

Authorized Distributor

Click to View Pricing, Inventory, Delivery & Lifecycle Information:

[ON Semiconductor:](#)

[NCP2824FCT2GEVB](#)