

**CARRIER TAPE FOR STANDARD SMT HEADERS.**

PART NUMBER	NO. OF CKTS	DIM A	DIM B	DIM C	DIM D	DIM E	DIM F	DIM G	PIECES PER BOX	REELS PER BOX	PIECES PER REEL
90814-*226/*526	26	56.0	52.4	26.2	38.0	62.4	56.4	150.0	1200	2	600
90814-*224/*524	24										
90814-*222/*522	22										

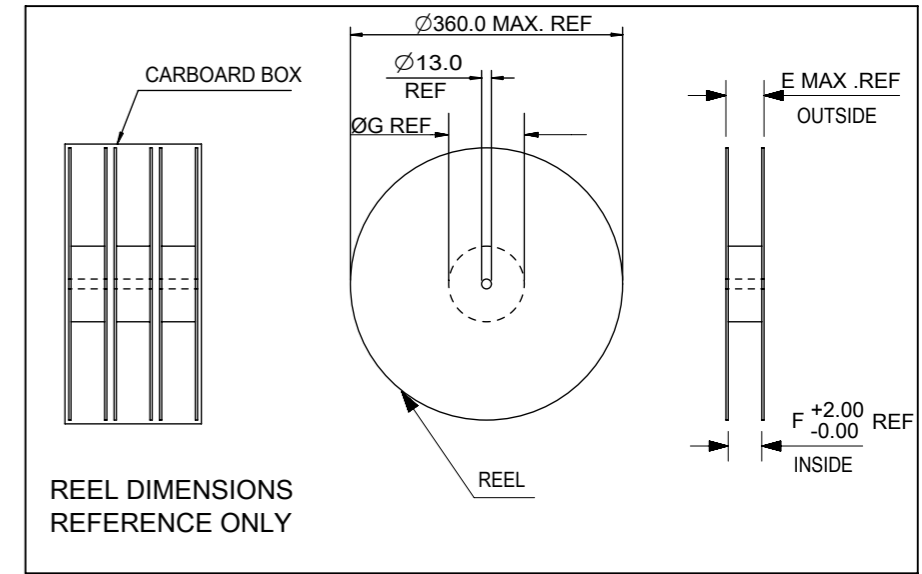

STANDARD SMT PICO FLEX COMPONENT & CAP DETAIL  
PART NUMBERS 90814-\*2\*\*/\*5\*\*  
SEE DRAWING NO. SDA-90814 FOR COMPONENT DETAIL

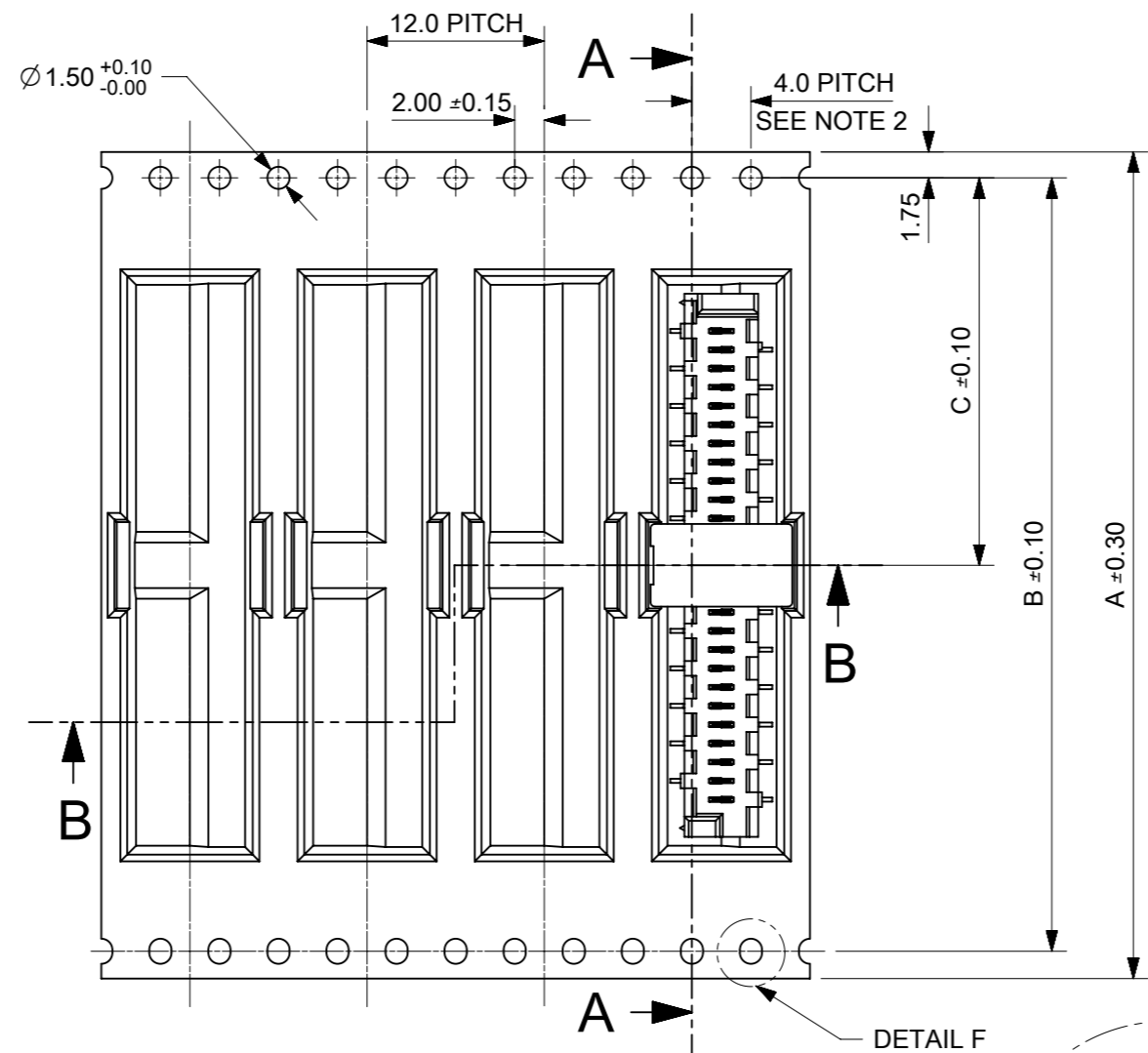
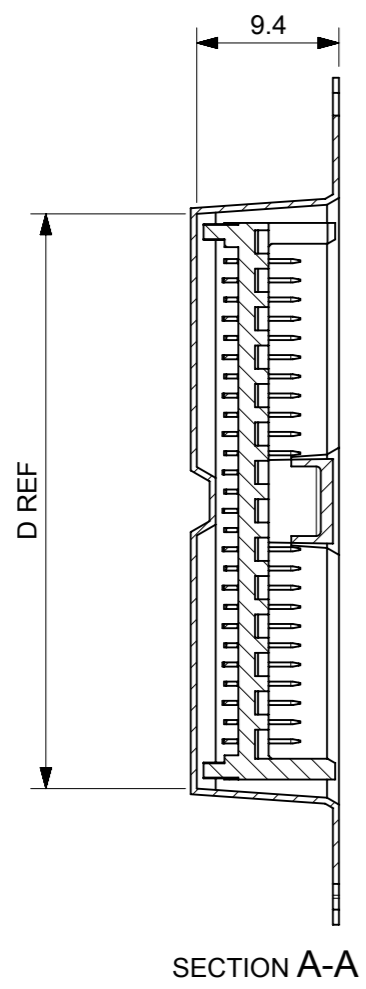
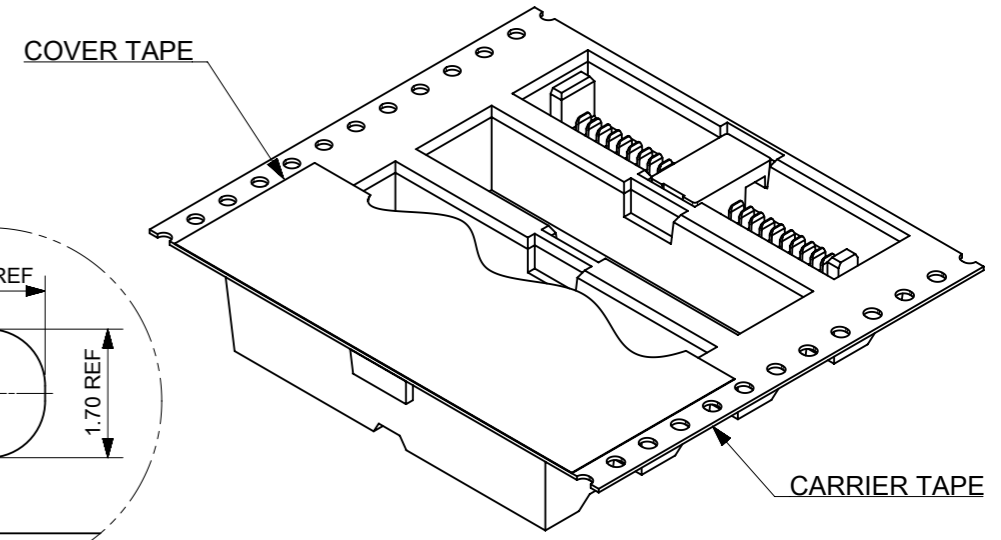
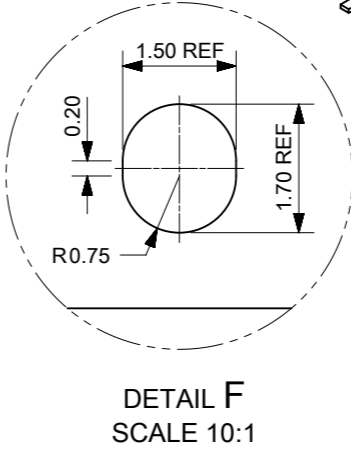
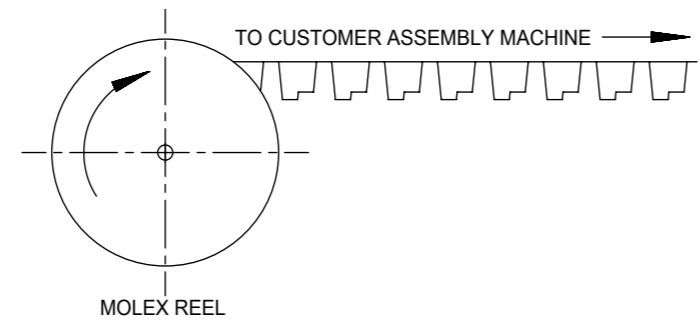
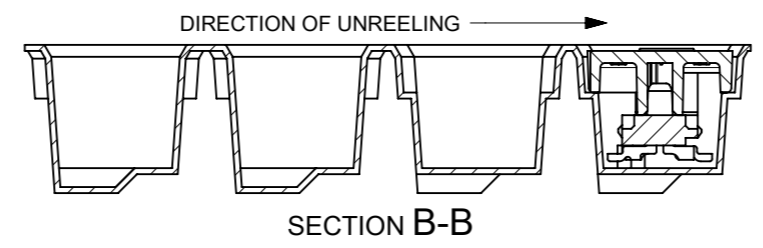
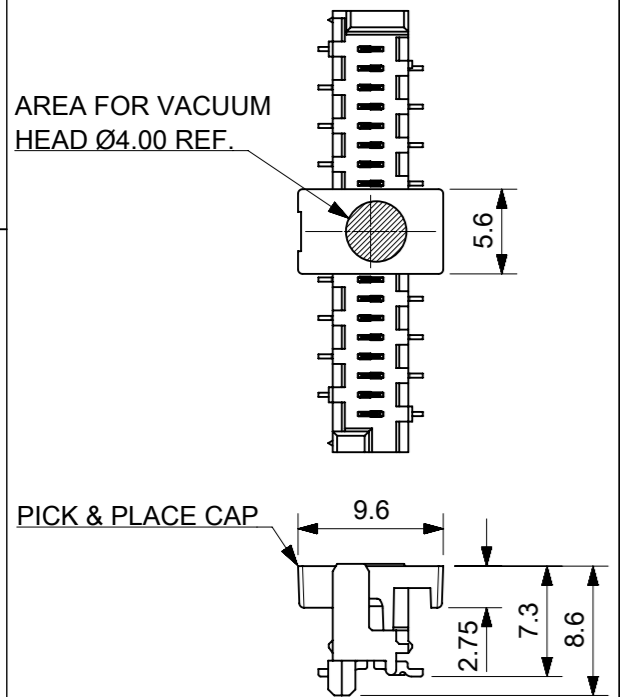

- NOTES:
- MATERIAL:  
CARRIER TAPE: VOLUME NON-CONDUCTIVE ANTISTATIC COATED POLYSTYRENE, 0.4 mm REF. THICK, CLEAR.  
COVER TAPE: COLD SEAL POLYESTER, 0.06 mm REF. THICK, TRANSPARENT.
  - PITCH TOLERANCE OVER ANY 10 PITCHES ± 0.2 mm.
  - ALL CAVITY WALLS HAVE DRAFT ANGLE UNLESS STATED OTHERWISE.
  - ALL INTERNAL RADII R0.3 mm MAX.
  - PEEL FORCE OF THE COVER TAPE IS 0.1 N TO 1.3 N AT MAXIMUM PEEL SPEED OF 300 mm/MIN, ± 10%.
  - REFERENCE TO IEC 60286-3.

THIS DRAWING CONTAINS INFORMATION THAT IS PROPRIETARY TO MOLEX ELECTRONIC TECHNOLOGIES, LLC AND SHOULD NOT BE USED WITHOUT WRITTEN PERMISSION		CURRENT REV DESC: REVISED		<b>molex</b>		
DIMENSION UNITS: mm	SCALE: 1.5:1					PICO FLEX SMT HEADER BLISTER TAPE
GENERAL TOLERANCES (UNLESS SPECIFIED)		EC NO: 169568		PRODUCT CUSTOMER DRAWING		
ANGULAR TOL	± 2.0°	DRWN: BPMURPHY	2017/12/05	DOCUMENT NUMBER: 908149001		
4 PLACES	±	CHK'D: DSHEA	2018/04/13	DOC TYPE: PSD	DOC PART: 000	
3 PLACES	±	APPR: DBYRNES	2018/04/18	REVISION: B		
2 PLACES	± 0.1	INITIAL REVISION:		SHEET NUMBER: 1 OF 2		
1 PLACE	± 0.2	DRWN: BPMURPHY	2017/09/25	MATERIAL NUMBER: SEE TABLE		
0 PLACES	±	APPR: DBYRNES	2017/11/17	CUSTOMER: GENERAL MARKET		
DRAFT WHERE APPLICABLE MUST REMAIN WITHIN DIMENSIONS		THIRD ANGLE PROJECTION	DRAWING: A3-SIZE	SERIES: 90814	SHEET NUMBER: 1 OF 2	

**CARRIER TAPE FOR LOW-PROFILE SMT HEADERS.**

PART NUMBER	NO. OF CKTS	DIM A	DIM B	DIM C	DIM D	DIM E	DIM F	DIM G	PIECES PER BOX	REELS PER BOX	PIECES PER REEL
90814-*726/-*926	26	56.0	52.4	26.2	38.0	62.4	56.4	150.0	1200	2	600
90814-*724/-*924	24										
90814-*722/-*922	22										

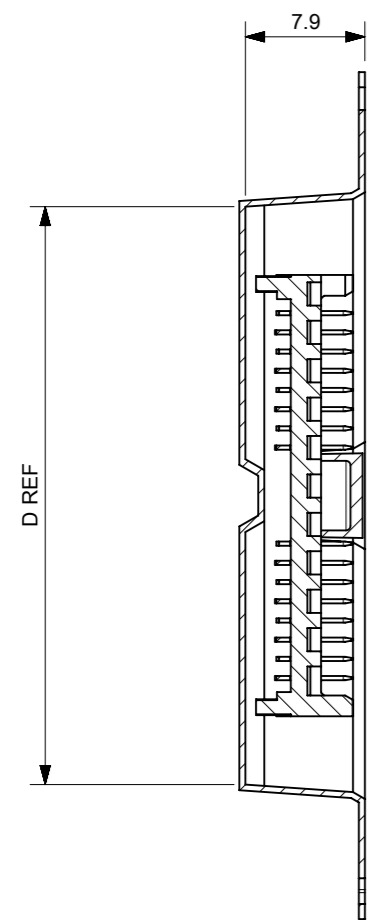

SECTION C-C

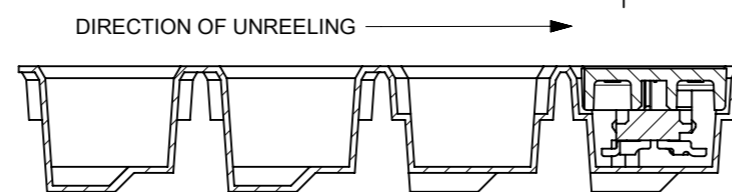
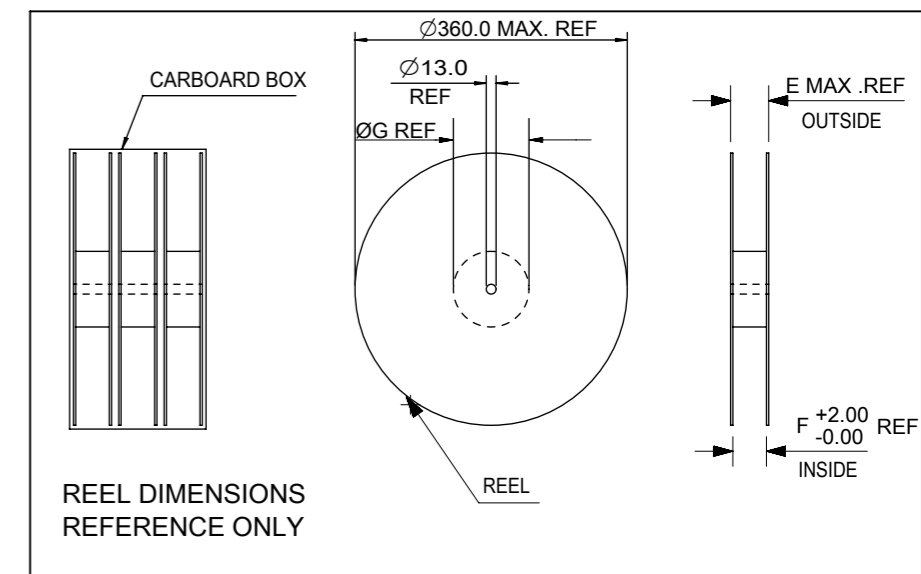
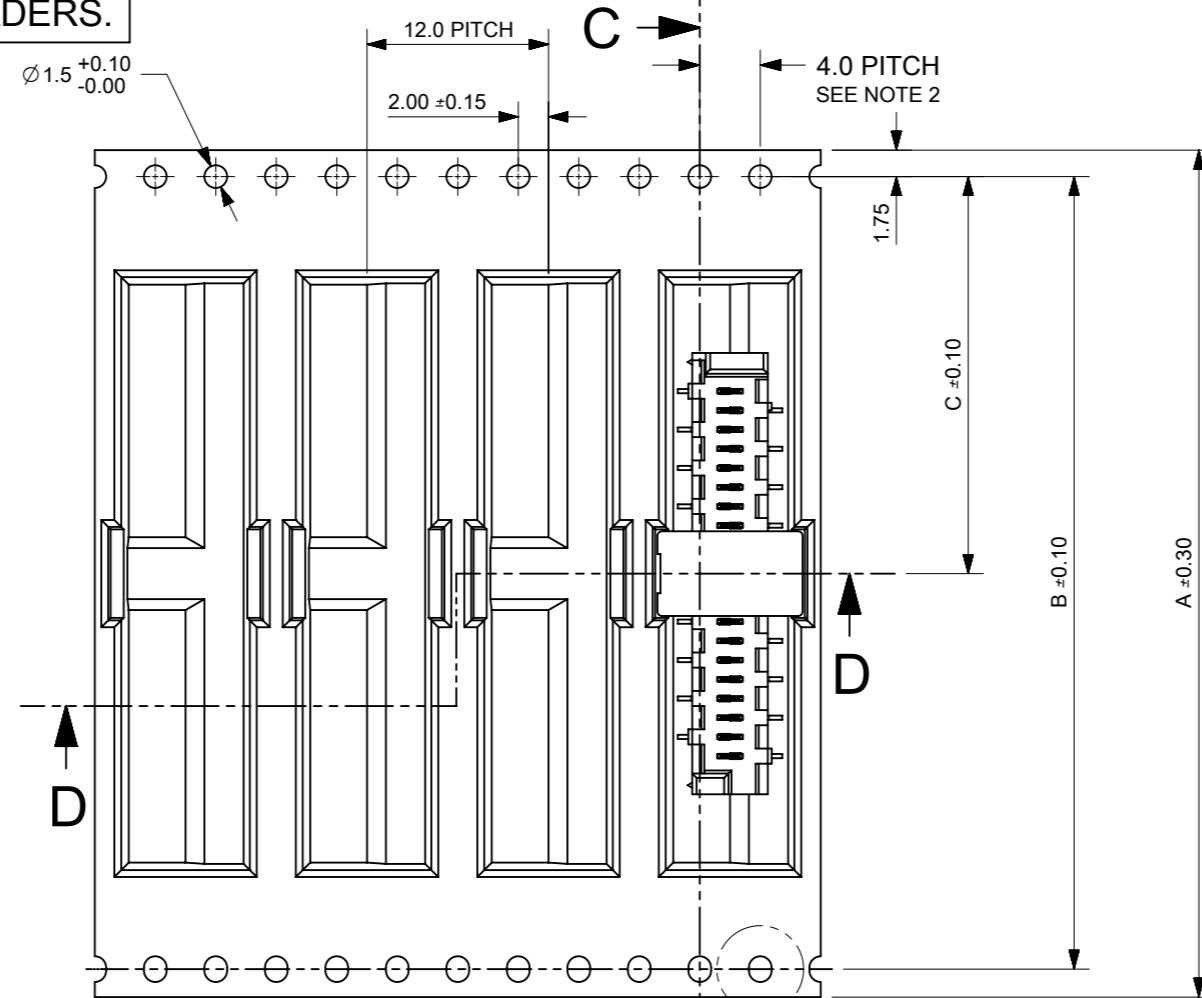

SECTION D-D

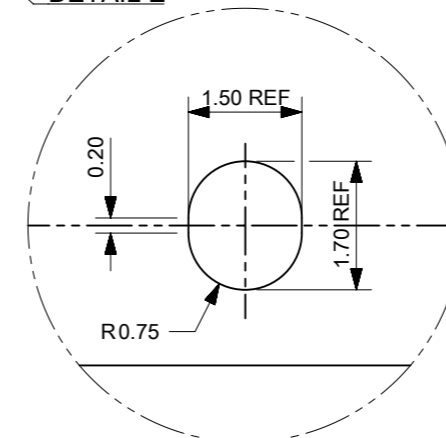

DETAIL E  
SCALE 10:1

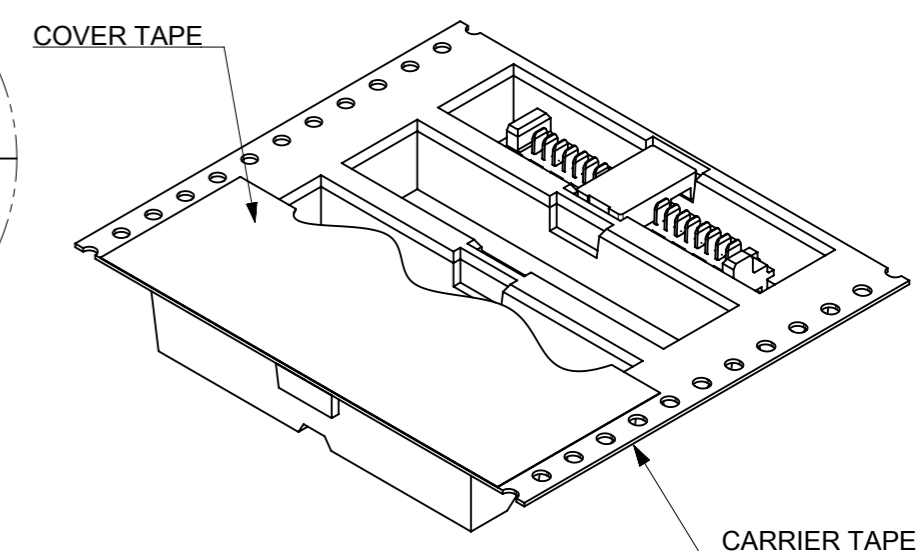

LOW-PROFILE SMT PICOFLEX COMPONENT & CAP DETAIL  
PART NUMBERS 90814-\*7\*\*/-\*9\*\*  
SEE DRAWING NO. SDA-90814 FOR COMPONENT DETAIL

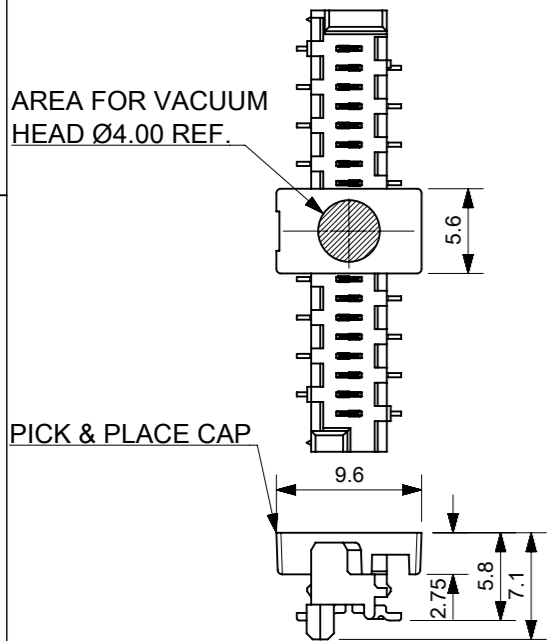

PICK & PLACE CAP

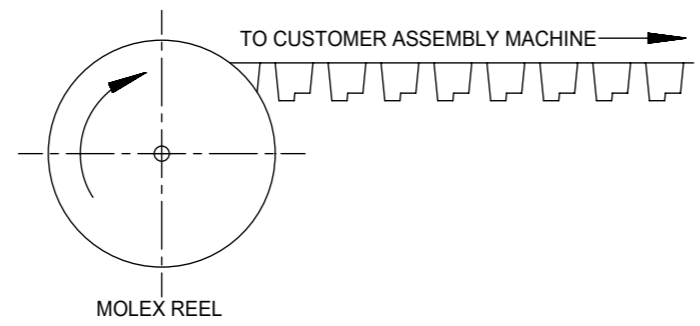

MOLEX REEL

- NOTES:
- MATERIAL:  
CARRIER TAPE: VOLUME NON-CONDUCTIVE ANTISTATIC COATED POLYSTYRENE, 0.4 mm REF. THICK, CLEAR.  
COVER TAPE: COLD SEAL POLYESTER, 0.06 mm REF. THICK, TRANSPARENT.
  - PITCH TOLERANCE OVER ANY 10 PITCHES ±0.2 mm.
  - ALL CAVITY WALLS HAVE DRAFT ANGLE UNLESS STATED OTHERWISE.
  - ALL INTERNAL RADII R0.3 mm MAX.
  - PEEL FORCE OF THE COVER TAPE IS 0.1 N TO 1.3 N AT MAXIMUM PEEL SPEED OF 300 mm/MIN, ±10%.
  - REFERENCE TO IEC 60286-3.

THIS DRAWING CONTAINS INFORMATION THAT IS PROPRIETARY TO MOLEX ELECTRONIC TECHNOLOGIES, LLC AND SHOULD NOT BE USED WITHOUT WRITTEN PERMISSION		CURRENT REV DESC: REVISED		<b>molex</b>		
DIMENSION UNITS	SCALE					PICOFLEX SMT HEADER BLISTER TAPE
mm	1.5:1			PRODUCT CUSTOMER DRAWING		
GENERAL TOLERANCES (UNLESS SPECIFIED)		EC NO: 169568		DOCUMENT NUMBER		
ANGULAR TOL	± 2.0°	DRWN: BPMURPHY 2017/12/05		908149001		
4 PLACES	±	CHK'D: DSHEA 2018/04/13		DOC TYPE DOC PART REVISION		
3 PLACES	±	APPR: DBYRNES 2018/04/18		PSD 000 B		
2 PLACES	± 0.1	INITIAL REVISION:		SHEET NUMBER		
1 PLACE	± 0.2	DRWN: BPMURPHY 2017/09/25		2 OF 2		
0 PLACES	±	APPR: DBYRNES 2017/11/17				
DRAFT WHERE APPLICABLE MUST REMAIN WITHIN DIMENSIONS		THIRD ANGLE PROJECTION	DRAWING	SERIES	MATERIAL NUMBER	CUSTOMER
			A3-SIZE	90814	SEE TABLE	GENERAL MARKET

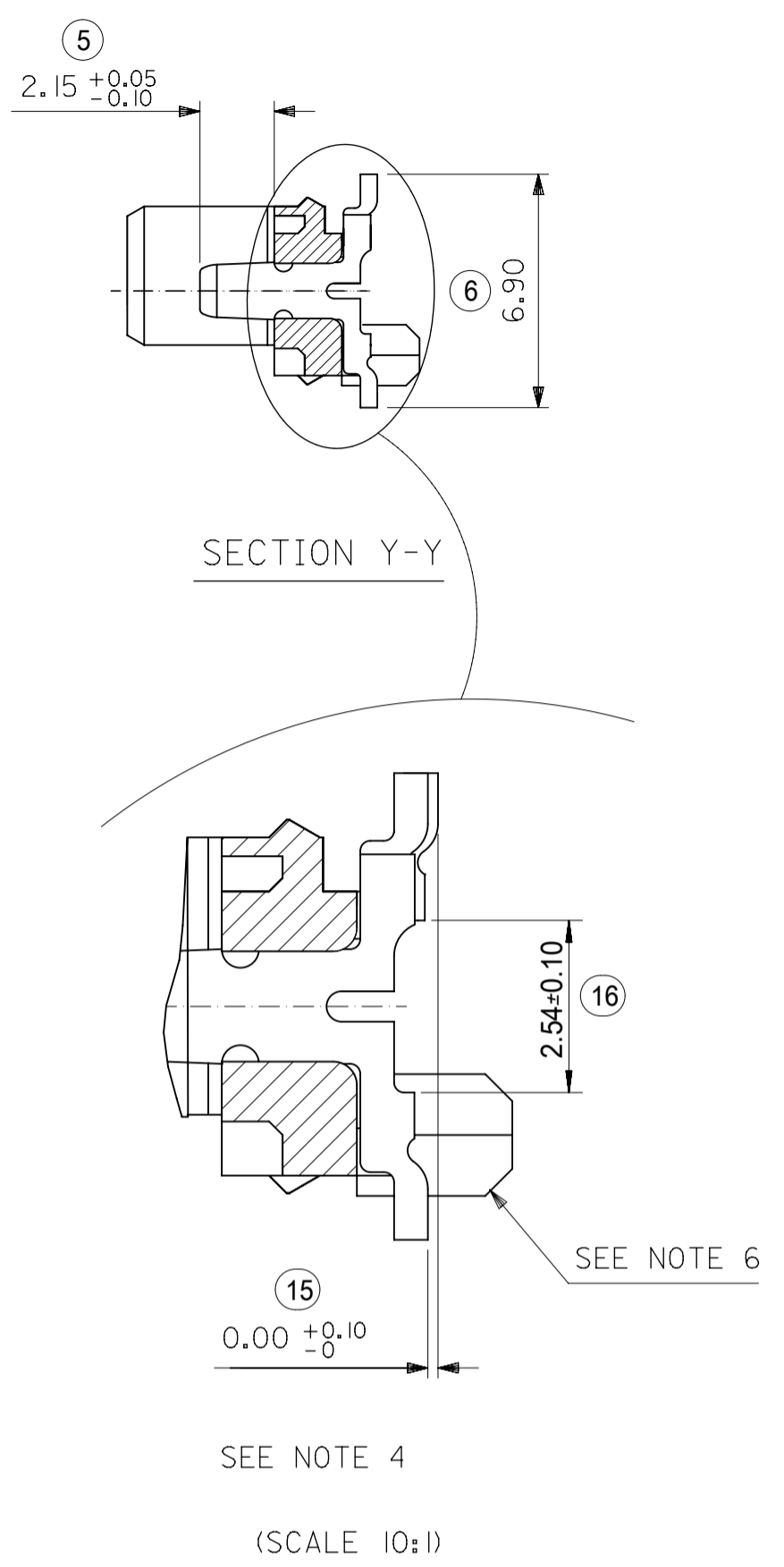
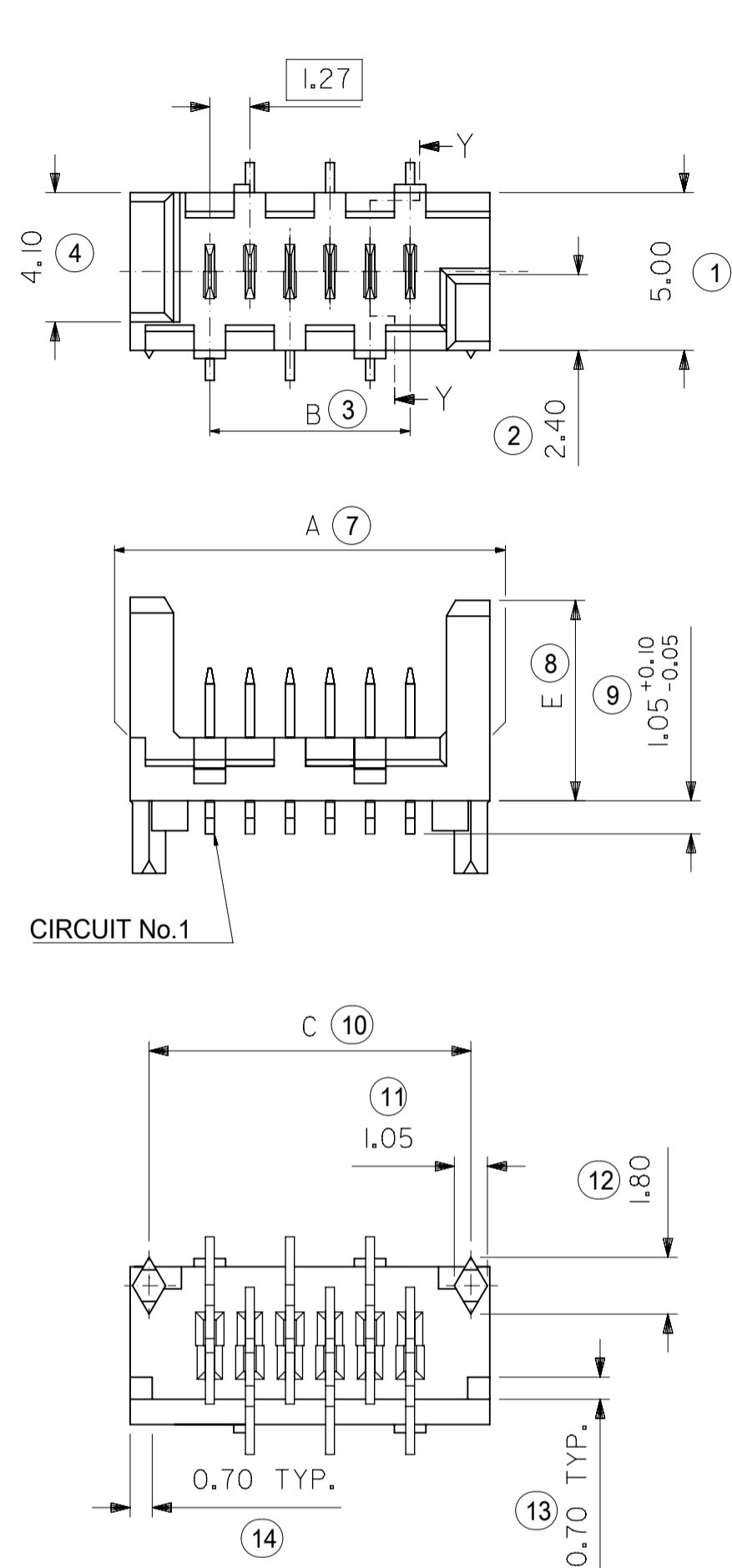

- NOTES:
- 1) MATERIAL: HOUSING: NYLON (PA) GLASS FILLED. UL94 V-0, NATURAL (BEIGE)  
TERMINAL - CARTRIDGE BRASS 0.28 REF THICK
  - 2) PLATING:  
TIN: TIN (Sn) 3-5 MICROMETRE OVER 1.27 MICROMETRE MIN NICKEL(Ni).  
PALLADIUM NICKEL (PdNi): 0.6 MICROMETRE SELECTIVE PdNi WITH 0.05 MICROMETRE GOLD FLASH IN CONTACT AREA AND 3-5 MICROMETRE SELECTIVE TIN IN SOLDER TAIL AREA OVER 1.27 MICROMETRE NICKEL(Ni) UNDERCOAT.
  - 3) MATES WITH MOLEX 90327 PART SERIES.
  - 4) ALL SMT TAILS TO LIE WITHIN A COPLANARITY BAND OF 0.0 - 0.10 REF. FROM EACH OTHER.
  - 5) FOR TAPE AND REEL PACKAGING SEE 908149001 PSD AND 908149002 PSD.  
FOR TUBE PACKAGING SEE PK-90814-001
  - 6) PCB PEGS ARE OPTIONAL.
  - 7) PCB LAYOUT SHOWN ON SHEET 2.
  - 8) PRODUCT SPECIFICATION: PS-99020-0011
  - 9) FOR RECOMMENDED REFLOW PROFILES, REFER TO PS-99020-0011 APPENDIX B

INSPECTION NUMBERS USED ON SHEET 1: 1-50  
LAST INSPECTION NUMBER: 16

90814 - \* \* \*  
CIRCUIT SIZE

	PCB PEGS	TUBE PACKED	TAPE & REEL PACKED	POLARIZING PEG HEIGHT DIMN. E	
0	YES	YES	NO	6.40	STANDARD
2	YES	NO	YES	6.40	PROFILE
3	NO	YES	NO	6.40	REFLOW
5	NO	NO	YES	6.40	NOTE 9
6	NO	YES	NO	4.10	LOW
7	NO	NO	YES	4.10	PROFILE
8	YES	YES	NO	4.10	REFLOW
9	YES	NO	YES	4.10	NOTE 9

0= 3-5 MICROMETRE TIN VERSION  
3= 0.6 MICROMETRE PALLADIUM NICKEL VERSION

90814-**-26	26	36.80	31.75	35.60	14	YES
90814-**-24	24	34.26	29.21	33.06	15	YES
90814-**-22	22	31.72	26.67	30.52	16	YES
90814-**-20	20	29.18	24.13	27.98	18	YES
90814-**-18	18	26.64	21.59	25.44	20	YES
90814-**-16	16	24.10	19.05	22.90	22	YES
90814-**-14	14	21.56	16.51	20.36	25	YES
90814-**-12	12	19.02	13.97	17.82	28	YES
90814-**-10	10	16.48	11.43	15.28	32	YES
90814-**-08	8	13.94	8.89	12.74	38	YES
90814-**-06	6	11.40	6.35	10.20	46	YES
90814-**-04	4	8.86	3.81	7.66	60	YES
PART NO.	NUMBER OF CKTS	DIMN. A	DIMN. B	DIMN. C	QUANTITY OF PARTS PER TUBE (-*0**/-*3**/-*6** & -*8** VERSIONS)	TOOLED

THIS DRAWING CONTAINS INFORMATION THAT IS PROPRIETARY TO MOLEX ELECTRONIC TECHNOLOGIES, LLC AND SHOULD NOT BE USED WITHOUT WRITTEN PERMISSION

DIMENSION UNITS	SCALE	CURRENT REV DESC: REVISED			
mm	5:1	<p><b>molex</b></p> <p>PICOFLEX SMT HEADER</p> <p>PRODUCT CUSTOMER DRAWING</p> <p>DOCUMENT NUMBER: <b>SDA-90814</b>   DOC TYPE: PSD   DOC PART: 001   REVISION: AB</p> <p>MATERIAL NUMBER: SEE CHART   CUSTOMER: GENERAL MARKET   SHEET NUMBER: 1 OF 2</p>			
GENERAL TOLERANCES (UNLESS SPECIFIED)					
ANGULAR TOL	± 0.5°				
4 PLACES	±				
3 PLACES	±				
2 PLACES	± 0.1	EC NO: 617828	DRWN: CFISHER01	2019/05/23	
1 PLACE	±	CHK'D: BRUTTLE	2019/05/23		
0 PLACES	±	APPR: BRUTTLE	2019/05/23		
DRAFT WHERE APPLICABLE MUST REMAIN WITHIN DIMENSIONS		INITIAL REVISION:	DRWN: DMCNAMAR	2001/08/16	
THIRD ANGLE PROJECTION		APPR: EFOLEN	2010/11/04		

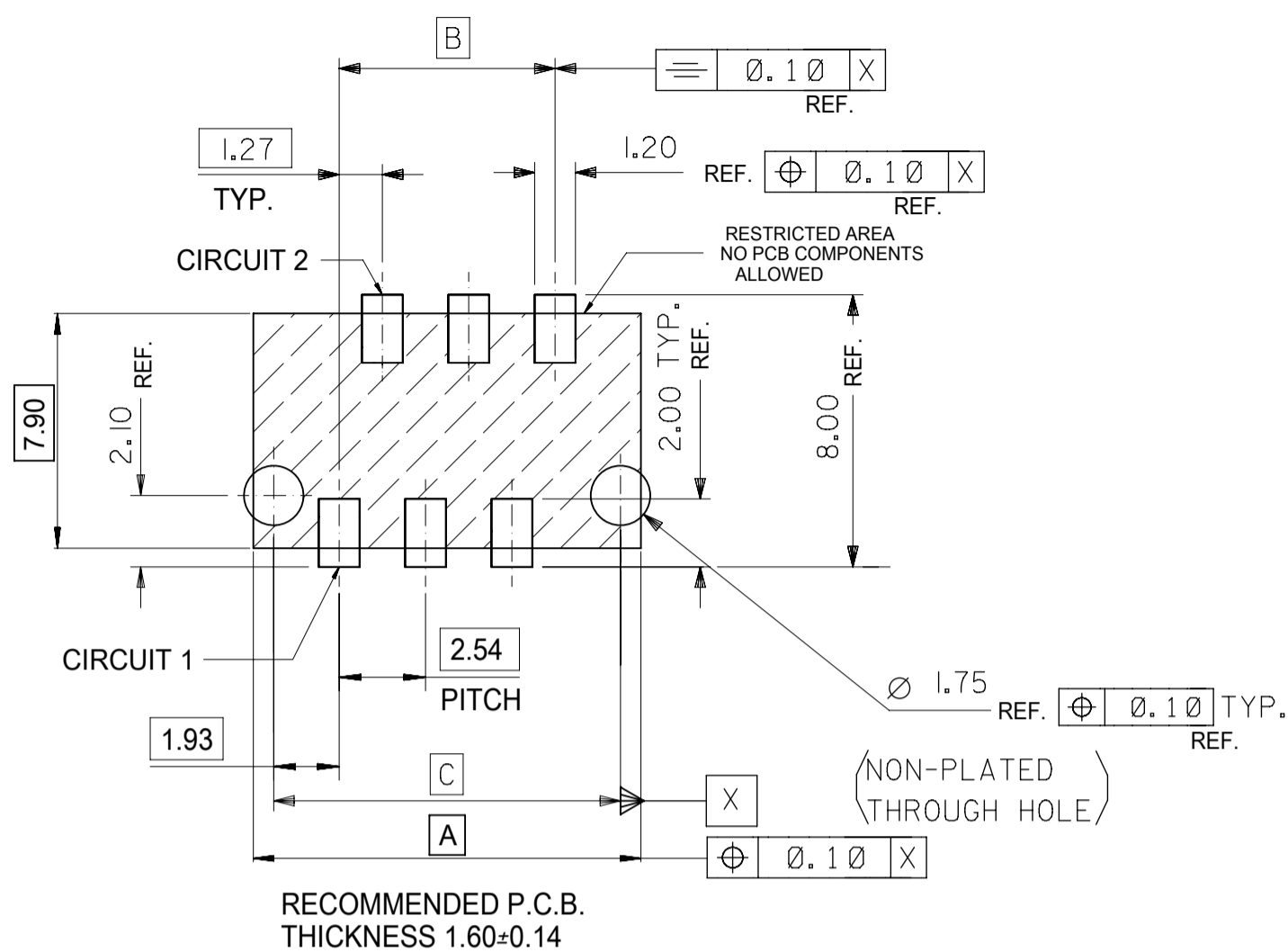

RECOMMENDED P.C.B. THICKNESS 1.60±0.14  
 PCB LAYOUT FOR TRANSITION FIT WITH PCB PEGS  
 HEADER VERSIONS 90814-xx0xx/-x2xx/-x8xx/-x9xx,  
 VIEWED FROM COMPONENT SIDE

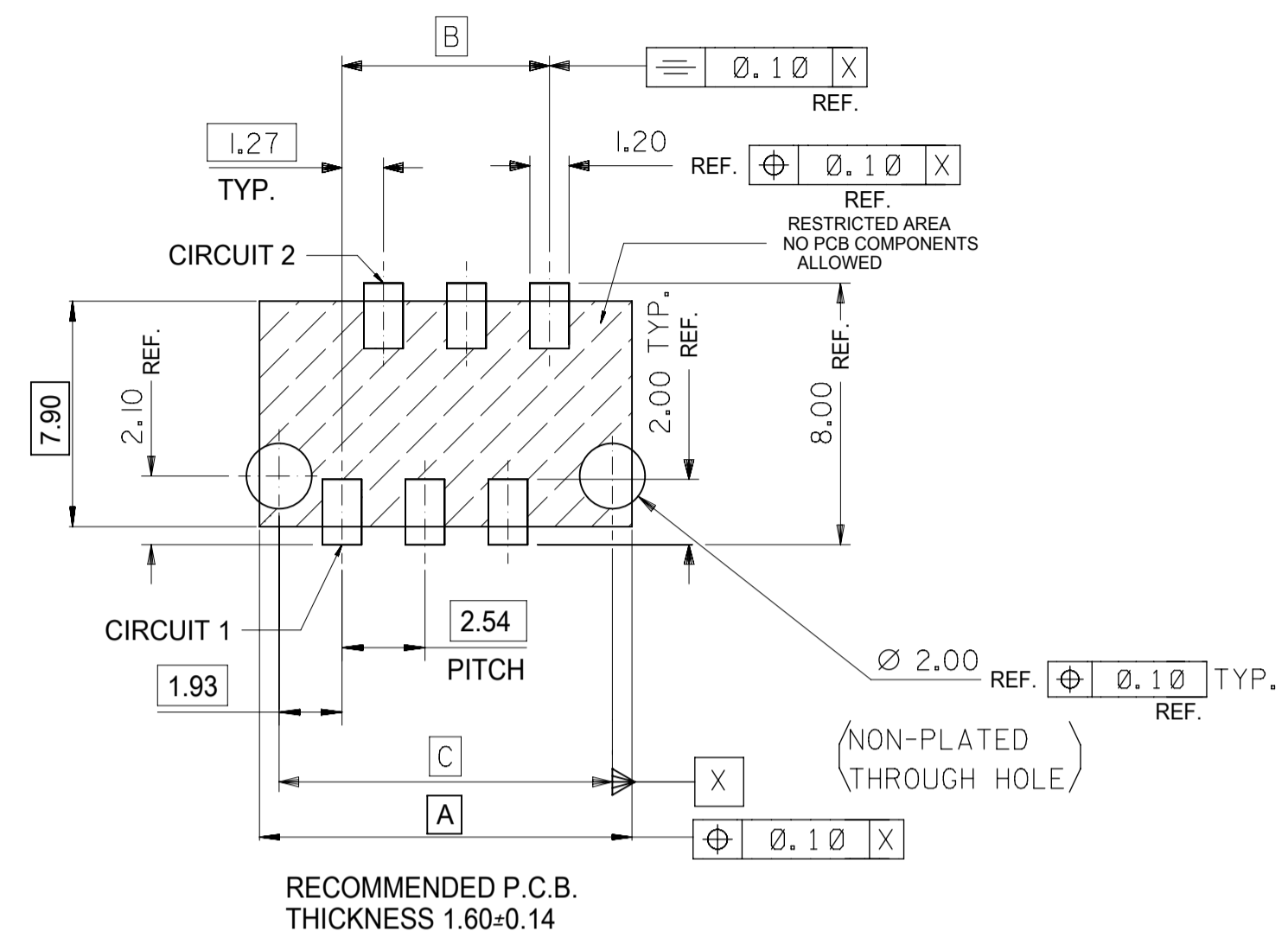

RECOMMENDED P.C.B. THICKNESS 1.60±0.14  
 PCB LAYOUT FOR CLEARANCE FIT WITH PCB PEGS  
 HEADER VERSIONS 90814-xx0xx/-x2xx/-x8xx/-x9xx,  
 VIEWED FROM COMPONENT SIDE

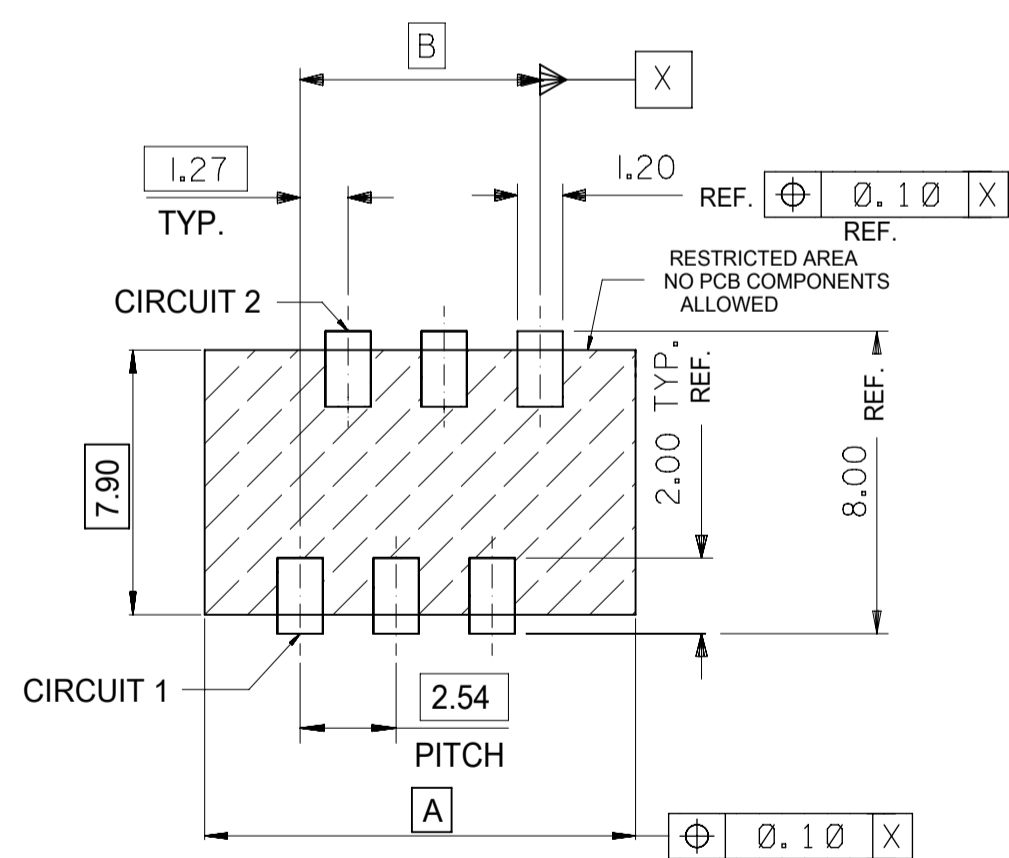

PCB LAYOUT FOR HEADERS WITHOUT PCB PEGS  
 HEADER VERSIONS 90814-xx3xx/-x5xx/-x6xx/-x7xx,  
 VIEWED FROM COMPONENT SIDE

90814-xx26	26	36.80	31.75	35.60
90814-xx24	24	34.26	29.21	33.06
90814-xx22	22	31.72	26.67	30.52
90814-xx20	20	29.18	24.13	27.98
90814-xx18	18	26.64	21.59	25.44
90814-xx16	16	24.10	19.05	22.90
90814-xx14	14	21.56	16.51	20.36
90814-xx12	12	19.02	13.97	17.82
90814-xx10	10	16.48	11.43	15.28
90814-xx08	8	13.94	8.89	12.74
90814-xx06	6	11.40	6.35	10.20
90814-xx04	4	8.86	3.81	7.66
PART NO.	NUMBER OF CKTS	DIMN. A	DIMN. B	DIMN. C

THIS DRAWING CONTAINS INFORMATION THAT IS PROPRIETARY TO MOLEX ELECTRONIC TECHNOLOGIES, LLC AND SHOULD NOT BE USED WITHOUT WRITTEN PERMISSION

DIMENSION UNITS	SCALE	CURRENT REV DESC: REVISED		
mm	5:1	<p>PICOFLEX SMT HEADER</p> <p>PRODUCT CUSTOMER DRAWING</p>		
GENERAL TOLERANCES (UNLESS SPECIFIED)				
ANGULAR TOL	± 0.5°			
4 PLACES	±			
3 PLACES	±			
2 PLACES	± 0.1			
1 PLACE	±	EC NO: 617828	2019/05/23	
0 PLACES	±	DRWN: CFISHER01	2019/05/23	
DRAFT WHERE APPLICABLE MUST REMAIN WITHIN DIMENSIONS		CHK'D: BRUTTLE	2019/05/23	
THIRD ANGLE PROJECTION		APPR: BRUTTLE	2019/05/23	
DRAWING		INITIAL REVISION:		
A2-SIZE		DRWN: DMCNAMAR	2001/08/16	
SERIES		APPR: EFOLEN	2010/11/04	
MATERIAL NUMBER		DOCUMENT NUMBER	DOC TYPE	
SEE CHART		SDA-90814	PSD	
CUSTOMER		DOC PART	REVISION	
GENERAL MARKET		001	AB	
SHEET NUMBER		2 OF 2		