

THIS DOCUMENT IS THE PROPERTY OF KEYSTONE ELECTRONICS CORP. AND SHALL NOT BE REPRODUCED, DISTRIBUTED OR USED AS A BASIS FOR MANUFACTURE WITHOUT PRIOR WRITTEN PERMISSION FROM KEYSTONE ELECTRONICS CORP.

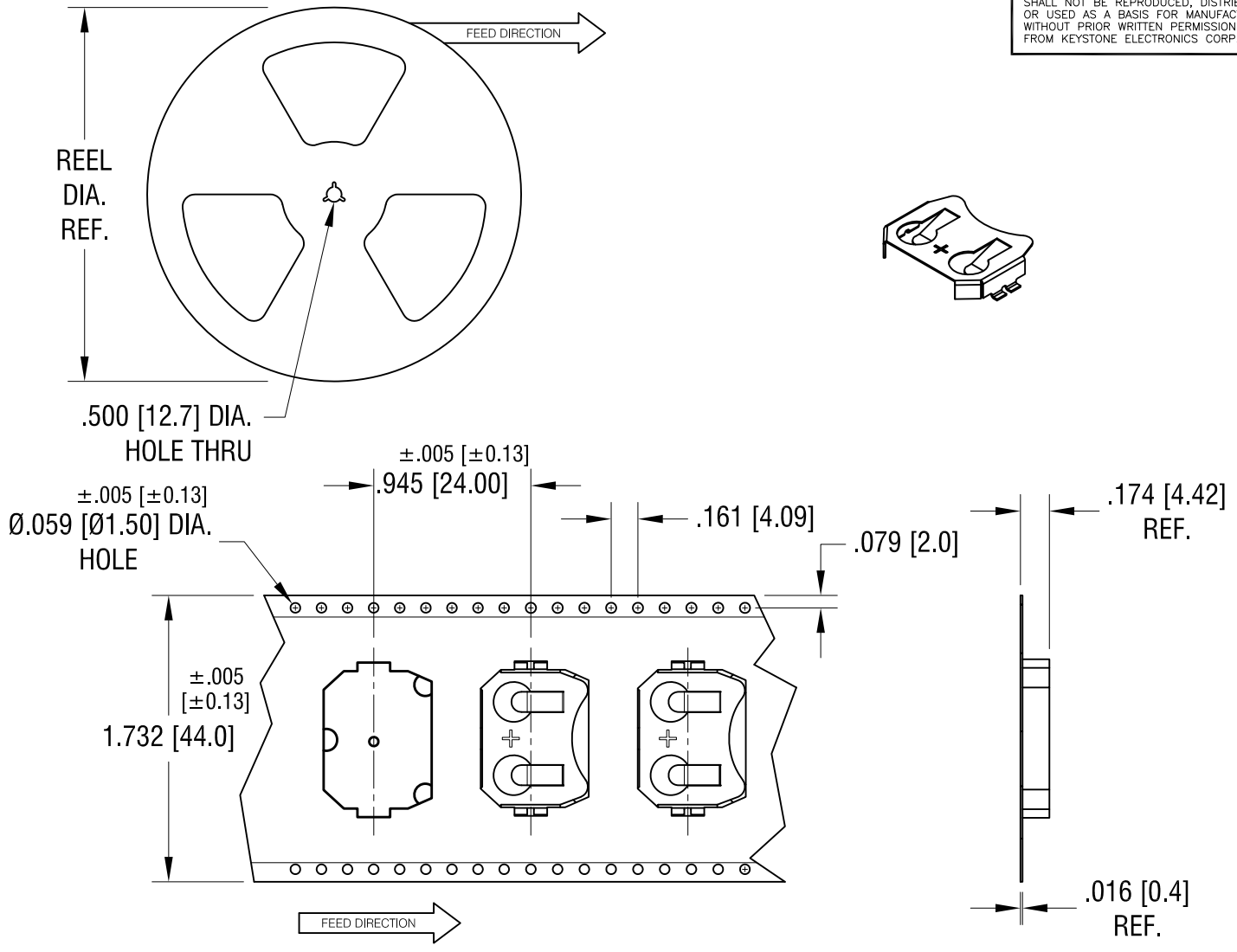

NOTES:

TAPE AND REEL SPECIFICATIONS:

1. TAPE:
MAT'L - ALL CONDUCTIVE POLYSTYRENE CARRIER
ANSI/EIA-481 STANDARD
2. REEL:
13.0 [330.2] DIA. 500 PIECES OF
PART NO. 3034 PER REEL.

8.02.11	CHANGE AS PER ECN 11-097	A
DATE	DESCRIPTION	REV.

KEYSTONE ELECTRONICS CORP.			
www.keyelco.com • NEW HYDE PARK, NY 11040 • Tel (516) 328-7500			
PART NAME		SM COIN CELL CLIP ON TAPE	
MATERIAL		AS NOTED	
FINISH	AS NOTED	DRN BY	NT
		DATE	6.15.11
		APP'D	LN
		SCALE	X
TOLERANCES	INCH [MM]	CODE	DWG NO.
DECIMAL	± .015 [± 0.38]	C	
ANGULAR	± 1°		
UNLESS OTHERWISE SPECIFIED			
			3034TR

Mouser Electronics

Authorized Distributor

Click to View Pricing, Inventory, Delivery & Lifecycle Information:

[Keystone Electronics:](#)

[3034TR](#)