

EC2C

S E R I E S

5 - 6 WATT DC-DC CONVERTERS

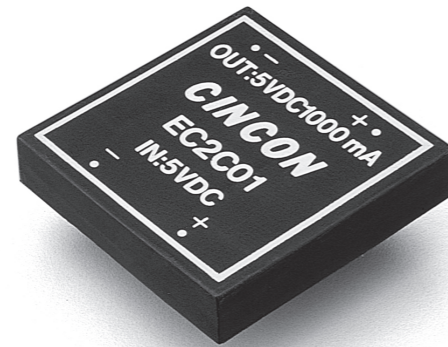

Features

- 5-6W Isolated Output
- 2" x 2" Case
- Regulated Outputs
- Efficiency to 60%
- Pi Input Filter
- 500VDC Isolation
- Alternative Pin Configuration

MODEL NUMBER	INPUT VOLTAGE	OUTPUT VOLTAGE	OUTPUT CURRENT	INPUT CURRENT		SIZE	ALT' PINOUT
				NO LOAD	FULL LOAD		
EC2C01	5 VDC	5 VDC	1000 mA	60 mA	1700 mA	2" x 2"	S
EC2C02		12 VDC	470 mA	70 mA	1750 mA		
EC2C03		15 VDC	400 mA	70 mA	1800 mA		
EC2C04		±12 VDC	±230 mA	130 mA	1700 mA		
EC2C05		±15 VDC	±190 mA	140 mA	1700 mA		
EC2C11	12 VDC	5 VDC	1000 mA	40 mA	690 mA	2" x 2"	S
EC2C12		12 VDC	470 mA	40 mA	700 mA		
EC2C13		15 VDC	400 mA	40 mA	750 mA		
EC2C14		±12 VDC	±230 mA	60 mA	710 mA		
EC2C15		±15 VDC	±190 mA	60 mA	710 mA		
EC2C21	24 VDC	5 VDC	1000 mA	20 mA	350 mA	2" x 2"	S
EC2C22		12 VDC	470 mA	20 mA	340 mA		
EC2C23		15 VDC	400 mA	20 mA	360 mA		
EC2C24		±12 VDC	±230 mA	35 mA	360 mA		
EC2C25		±15 VDC	±190 mA	35 mA	360 mA		
EC2C31	28 VDC	5 VDC	1000 mA	20 mA	290 mA	2" x 2"	S
EC2C32		12 VDC	470 mA	20 mA	300 mA		
EC2C33		15 VDC	400 mA	20 mA	310 mA		
EC2C34		±12 VDC	±230 mA	25 mA	290 mA		
EC2C35		±15 VDC	±190 mA	25 mA	290 mA		
EC2C41	48 VDC	5 VDC	1000 mA	14 mA	170 mA	2" x 2"	S
EC2C42		12 VDC	470 mA	14 mA	170 mA		
EC2C43		15 VDC	400 mA	14 mA	180 mA		
EC2C44		±12 VDC	±230 mA	20 mA	170 mA		
EC2C45		±15 VDC	±190 mA	20 mA	170 mA		

NOTE: 1. Alternative pin-out version. To order, suffix a "S" to the standard model number.

Specifications

INPUT SPECIFICATIONS:

Input Voltage Range.....±10%
Input Filter.....Pi Type

OUTPUT SPECIFICATIONS:

Voltage Accuracy.....±1.0% max.
Voltage Balance, Dual Output.....±0.5% max.
Temperature Coefficient
Single Output.....±0.02%/°C
Dual Output.....±0.01%/°C
Ripple and Noise, 20MHz BW
Single Output.....50mV p-p max.
Dual Output.....35mV p-p max.
Short Circuit Protection.....Short Term
Line Regulation.....±0.02%
Load Regulation.....±0.05%

GENERAL SPECIFICATIONS:

Efficiency.....60%
Isolation Voltage.....500 VDC min.
Isolation Capacitance.....80pF
Isolation Resistance.....10⁹ohms
Switching Frequency.....20KHz, min.
Operating Ambient Temperature Range.....-25°C to +71°C
De-rating, Above 71°C (Plastic Case).....Linearly to Zero power at 95°C
De-rating, Above 71°C (Copper Case).....Linearly to Zero power at 100°C
Case Temperature (Plastic case²)95°C max
(Copper case²)100°C max
CoolingNatural Convection
Storage Temperature Range.....-40°C to +100°C
Dimensions.....2.00 x 2.00 x 0.40 inches
(50.8 x 50.8 x 10.2mm)
Weight.....51g

CASE MATERIAL:

Standard Models.....Non-Conductive Black Plastic
Suffix "M" Models⁵.....Black Coated Copper with Non-Conductive Base

EC2C Series Derating Curve

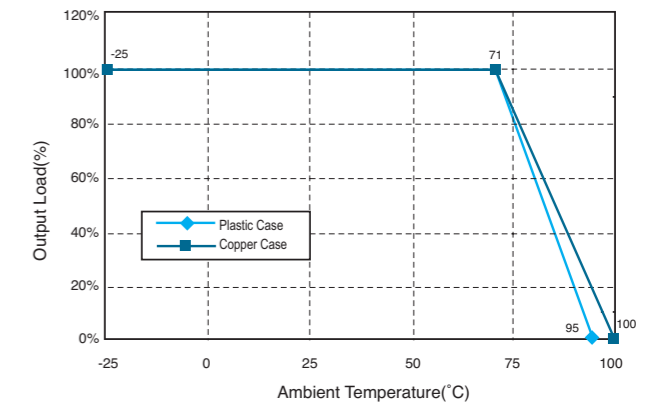

NOTE:

1. Alternative pin-out version. To order, suffix a "S" to the standard model number.
2. Maximum case temperature under any operating condition should not exceed 95°C (Plastic Case), 100°C (Copper Case).

INPUT VOLTAGE	60% FL	80% FL	100% FL
5V	4.4-6.5V	4.5-6.0V	4.65-5.5V
12V	10.56-15.6V	10.8-14.4V	11.16-13.2V
24V	21.12-31.2V	21.6-28.8V	22.32-26.4V
28V	24.64-36.4V	25.2-33.6V	26.04-30.8V
48V	42.24-62.4V	43.2-57.6V	44.64-52.8V

CASE C

All Dimensions In Inches(mm)
Tolerance Inches: .xx= ±.04, .xxx= ±.010
Millimeters: .x= ±1.0, .xx= ±0.25

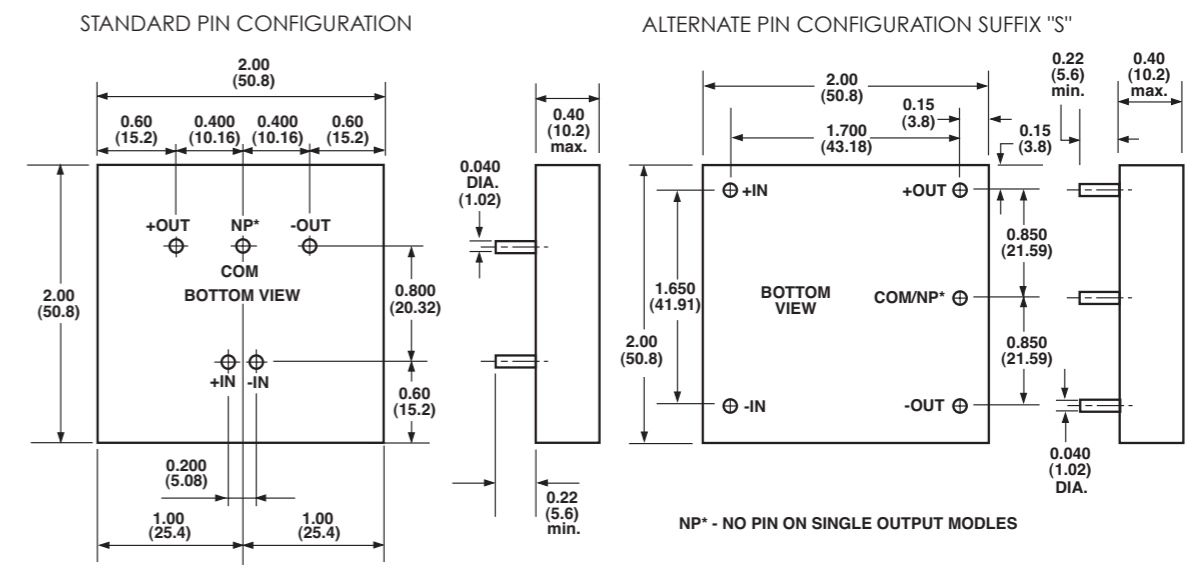

All Specifications Typical At Nominal Line, Full Load and 25°C Unless Otherwise Noted.

Mouser Electronics

Authorized Distributor

Click to View Pricing, Inventory, Delivery & Lifecycle Information:

Cincon:

[EC2C05S](#) [EC2C01](#) [EC2C02](#) [EC2C03](#) [EC2C04](#) [EC2C05](#) [EC2C11](#) [EC2C12](#) [EC2C13](#) [EC2C14](#) [EC2C15](#)
[EC2C21](#) [EC2C22](#) [EC2C23](#) [EC2C24](#) [EC2C25](#) [EC2C31](#) [EC2C32](#) [EC2C33](#) [EC2C34](#) [EC2C35](#) [EC2C41](#) [EC2C42](#)
[EC2C43](#) [EC2C44](#) [EC2C45](#) [EC2C23S](#) [EC2C32S](#) [EC2C25S](#) [EC2C01S](#) [EC2C03S](#) [EC2C31S](#) [EC2C41S](#) [EC2C33S](#)
[EC2C01M](#) [EC2C02M](#) [EC2C03M](#) [EC2C11M](#) [EC2C12M](#) [EC2C13M](#) [EC2C21M](#) [EC2C22M](#) [EC2C23M](#) [EC2C31M](#)
[EC2C32M](#) [EC2C33M](#) [EC2C41M](#) [EC2C42M](#) [EC2C43M](#) [EC2C04M](#) [EC2C05M](#) [EC2C14M](#) [EC2C15M](#) [EC2C24M](#)
[EC2C25M](#) [EC2C34M](#) [EC2C35M](#) [EC2C44M](#) [EC2C45M](#) [EC2C02S](#) [EC2C21S](#) [EC2C11S](#) [EC2C04S](#) [EC2C44S](#)
[EC2C12S](#) [EC2C15S](#) [EC2C13S](#) [EC2C24S](#) [EC2C43S](#) [EC2C45S](#) [EC2C42S](#) [EC2C14S](#) [EC2C35S](#) [EC2C22S](#)
[EC2C34S](#) [EC2C05MS](#)