

# 4-Channel White LED Driver with Integrated FET for up to 24 LEDs



## BD6586MUV

### General Description

BD6586MUV is white LED driver IC with PWM step-up DC/DC converter that can boost max 24V and current driver that can drive max 25mA. The wide and precision brightness can be controlled by external PWM pulse.

BD6586MUV has very accurate current drivers, and it has few current errors between each strings. So, it will be helpful to reduce brightness spots on the LCD. Small package type is suited for saving space.

### Key Specifications

- Operating power supply voltage range: 2.7V to 5.5V
- LED maximum current: 25mA (Max.)
- Quiescent Current: 0.1μA (Typ.)
- Switching frequency: 1.0MHz(Typ.)
- Operating temperature range: -40 to +85

**Package** W(Typ.) x D(Typ.) x H(Max.)

### Features

- High accuracy & good matching ( $\pm 3.0\%$ ) current drivers 4ch (MAX.25mA/ch)
- 28V power Nch MOSFET
- Soft Start
- Drive up to 6 in series, 4 strings in parallel
- Rich safety functions
  - Over-voltage protection
  - Output Short protection
  - External SBD open detect
  - Over current limit
  - Thermal shutdown
  - UVLO



**VQFN024V4040**  
4.00mm x 4.00mm x 1.00mm

Figure 1.

### Applications

All middle size LCD equipments backlight of Notebook PC, portable DVD player, car navigation systems, etc.

### Typical Application Circuit

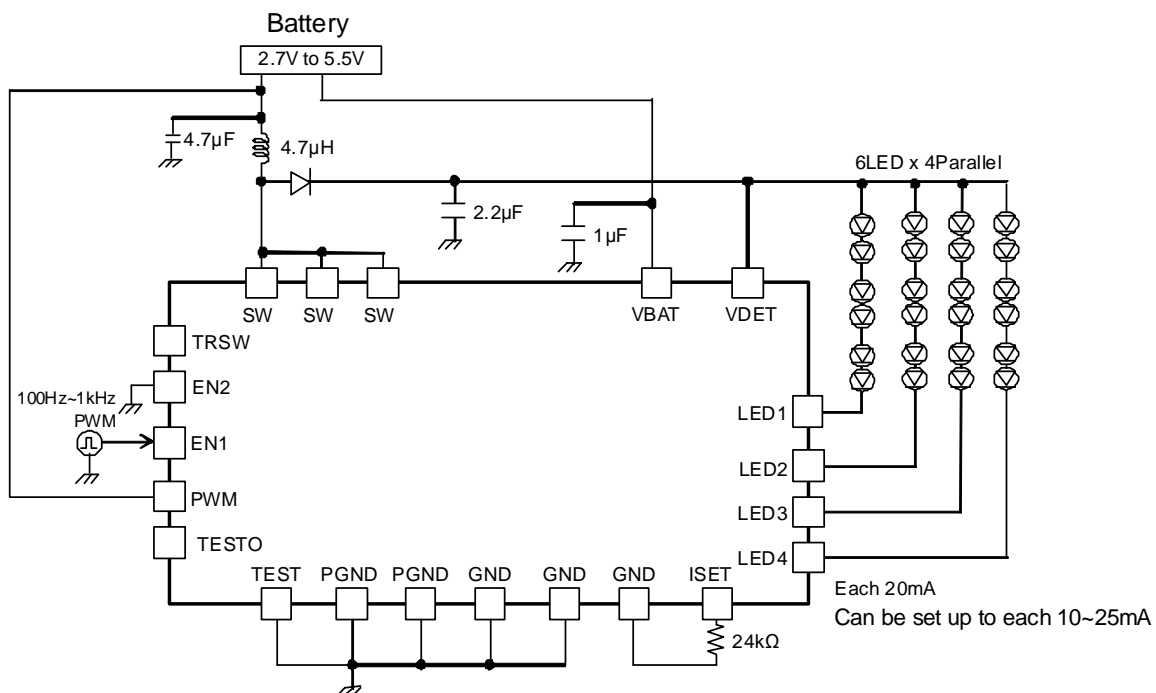

Figure 2. Typical Application Circuit  
(Power control PWM application)

Product structure : Silicon monolithic integrated circuit This product is not designed protection against radioactive rays

**Absolute Maximum Ratings** (Ta=25 )

Parameter	Symbol	Ratings	Unit	Condition
Terminal voltage 1	VMAX1	7	V	VBAT, EN1, EN2, TRSW, PWM,TESTO, ISET, TEST
Terminal voltage 2	VMAX2	25	V	LED1, LED2, LED3, LED4,
Terminal voltage 3	VMAX3	30.5	V	SW
Terminal voltage 4	VMAX4	50.5	V	VDET
Power dissipation 1	Pd1	500 <sup>*1</sup>	mW	
Power dissipation 2	Pd2	780 <sup>*2</sup>	mW	
Power dissipation 3	Pd3	1510 <sup>*3</sup>	mW	
Operating temperature range	Topr	-40 to +85		
Storage temperature range	Tstg	-55 to +150		

\*1 Reduced 4.0mW/ With Ta>25 when not mounted on a heat radiation Board.

\*2 1 layer (ROHM Standard board) has been mounted. Copper foil area 0mm<sup>2</sup>, When it's used by more than Ta=25 , it's reduced by 6.2mW/ .

\*3 4 layer (JEDEC Compliant board) has been mounted.

Copper foil area 1layer 6.28mm<sup>2</sup>, Copper foil area 2 to 4layers 5655.04mm<sup>2</sup>, When it's used by more than Ta=25 , it's reduced by 12.1mW/ .

**Recommended Operating Rating** (Ta=-40 to +85 )

Parameter	Symbol	Limits			Unit	Condition
		Min.	Typ.	Max.		
Power supply voltage	VBAT	2.7	3.6	5.5	V	

**Electrical Characteristics**

(Unless otherwise specified, VBAT=3.6V, Ta = +25 )

Parameter	Symbol	Limits			Unit	Condition
		Min.	Typ.	Max.		
<b>[EN1, EN2, PWM Terminal]</b>						
EN threshold voltage (Low)	VthL	0	-	0.4	V	
EN threshold voltage (High)	VthH	1.4	-	5.5	V	
EN terminal input current	Iin	-	8.3	16.0	μA	Input=2.5V
<b>[Under Voltage Lock Out]</b>						
Under Voltage Lock Out	UVLO	2.05	2.35	2.65	V	VBAT falling edge
<b>[Switching Regulator]</b>						
Quiescent Current	Iq	-	0.1	2.0	μA	EN1=EN2=PWM=0V
Current Consumption	Idd	-	2.2	4.6	mA	VDET=0V,ISET=24kΩ
LED Control voltage	VLED	0.4	0.5	0.6	V	
Over Current Limit	Ocp	1.1	1.5	2.5	A	*1
SBD Open Protect	Sop	-	-	0.1	V	Detect voltage of VDET pin
Switching frequency	fSW	0.7	1.0	1.3	MHz	
Duty cycle limit	Duty	91	95	99	%	LED1-4=0.3V
Over voltage limit	Ovl	25.0	25.5	26.0	V	LED1-4=0.3V
SW Transistor On Resistance	RSW	-	0.24	0.32	Ω	Isw=100mA
<b>[Current driver]</b>						
LED maximum current	ILMAX	-	-	25	mA	
LED current accuracy	ILACCU	-	-	±5	%	ILED=20mA
LED current matching	ILMAT	-	-	±3	%	•Each LED current/Average (LED1- 4) •ILED=20mA
ISET voltage	Iset	0.5	0.6	0.7	V	
LED current limiter	ILOCP	35	60	90	mA	Current limit value at ISET resistance 4.7kΩ setting LED1, 2, 3, 4=0.5V
LED Terminal Over Voltage Protect	LEDOVP	10.0	11.5	13.0	V	EN1=EN2=PWM=2.5V

\*1 This parameter is tested with DC measurement.

Pin Descriptions

PIN Name	In/Out	PIN number	Function	Terminal equivalent circuit diagram
1	VBAT	In	Battery input	G
2	EN1	In	Power control pin	A
3	EN2	In	Power control pin	A
4	GND	-	GND for DC/DC	B
5	PWM	In	PWM input pin for power ON/OFF only driver	A
6	ISET	In	Register connection for LED current setting	D
7	GND	-	GND for ISET Register	B
8	LED1	In	Current sink for LED1	C
9	LED2	In	Current sink for LED2	C
10	GND	-	GND for Current Driver	B
11	LED3	In	Current sink for LED3	C
12	LED4	In	Current sink for LED4	C
13	TEST	In	TEST input (Pull down 100kΩ to GND)	A
14	TESTO	Out	TEST output	D
15	N.C.	-	No connect pin	E
16	SW	Out	Switching Tr drive Pin	F
17	SW	Out	Switching Tr drive Pin	F
18	SW	Out	Switching Tr drive Pin	F
19	VDET	In	Detect input for SBD open and OVP	C
20	N.C.	-	No connect pin	E
21	PGND	-	PGND for switching transistor	D
22	PGND	-	PGND for switching transistor	D
23	N.C.	-	No connect pin	E
24	TRSW	Out	The gate of Switching Tr	D
-	Thermal PAD	-	Heat radiation PAD of back side Connect to GND	-

Pin ESD Type

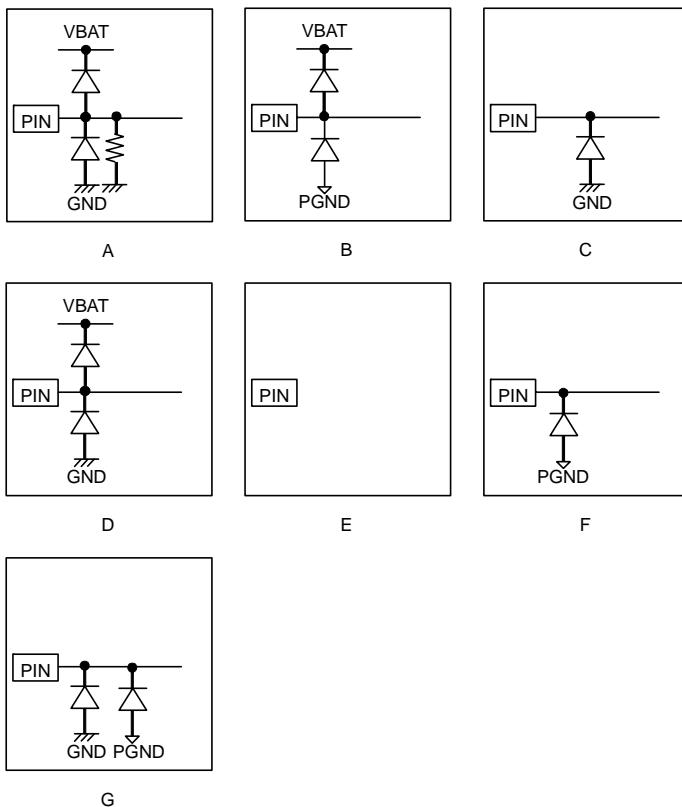
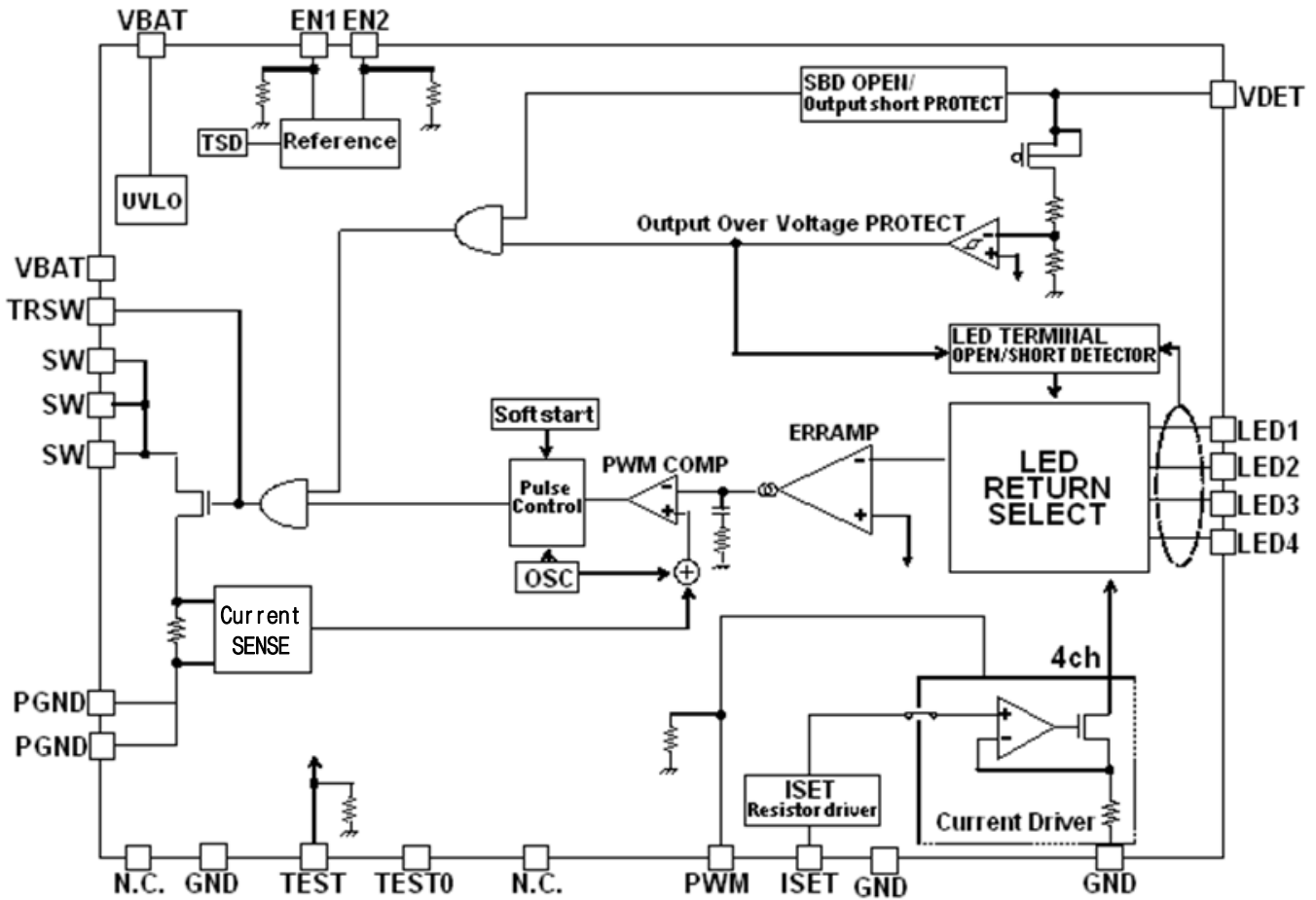

Figure 3. Pin ESD Type

Block Diagram



Pin number 24pin  
Figure 4. Block diagram

### Description of Functions

#### 1) PWM current mode DC/DC converter

While BD6586MUV is power ON, the lowest voltage of LED1, 2, 3, 4 is detected, PWM duty is decided to be 0.5V and output voltage is kept invariably. As for the inputs of the PWM comparator as the feature of the PWM current mode, one is overlapped with error components from the error amplifier, and the other is overlapped with a current sense signal that controls the inductor current into Slope waveform to prevent sub harmonic oscillation. This output controls internal Nch Tr via the RS latch. In the period where internal Nch Tr gate is ON, energy is accumulated in the external inductor, and in the period where internal Nch Tr gate is OFF, energy is transferred to the output capacitor via external SBD. BD6586MUV has many safety functions, and their detection signals stop switching operation at once.

#### 2) Soft start

BD6586MUV has soft start function.

The soft start function prevents large coil current.

Rush current at turning on is prevented by the soft start function.

After EN1, EN2 are changed L→H, soft start becomes effective for within 1ms and soft start doesn't become effective even if EN1, EN2 are changed L→H after that.

And, when the H section of PWM is within 1ms, soft start becomes invalid when PWM is input to H more than three times. The invalid of the soft start can be canceled by making EN1, EN2, PWM → L.

And, a soft start function doesn't work after a protection function release.

**Description of Functions - continued**

- 3) External SBD open detect and over voltage protection  
 BD6586MUV has over boost protection by external SBD open and over voltage protection. It detects VDET voltage and is stopped output Tr in abnormal condition. Details are as shown below.
- External SBD open detect  
 In the case of external SBD is not connected to IC, the coil or internal Tr may be destructed. Therefore, at such an error as VOUT becoming 0.1V or below, the Under Detector shown in the figure works, and turns off the output Tr, and prevents the coil and the IC from being destructed.  
 And the IC changes from activation into non-activation, and current does not flow to the coil (0mA).
  - Over voltage protection  
 At such an error of output open as the output DC/DC and the LED is not connected to IC, the DC/DC will boost too much and the VDET terminal exceed the absolute maximum ratings, and may destruct the IC. Therefore, when VDET becomes sensing voltage or higher, the over voltage limit works, and turns off the output Tr, and the pressure up made stop.  
 At this moment, the IC changes from activation into non-activation, and the output voltage goes down slowly. And, when the output voltage becomes the hysteresis of the over voltage limit or below, the output voltage pressure up to sensing voltage once again and unless the application error is recovered, this operation is repeated.
- 4) Thermal shut down  
 BD6586MUV has thermal shut down function.  
 The thermal shut down works at 175°C or higher, and while holding the setting of EN1, EN2 control from the outside, turns into non operation condition from operation condition. And at 175°C or below, the IC gets back to its normal operation.
- 5) Over Current Limit  
 Over current flows the current detection resistor between switching transistor source and PGND, then the voltage of that resistor turns more than detection voltage. Over current protection is operating and it is prevented from flowing more than detection current by reducing ON duty of switching Tr without stopping boost.  
 As over current detector of BD6586MUV is detected peak current, current more than over current setting value does not flow.
- 6) Under Voltage Lock Out(UVLO)  
 When VBAT declines in 2.35V (Typ.) from the condition of the power-on, DC/DC and a current driver are changed from a state of movement to the condition at the time of the non-movement. And, it is returned in a state of movement when VBAT is raised beyond 2.55V (Typ.).

**Operating of the Application Deficiency**

- 1) When 1 LED or 1parallel OPEN during the operating the LED parallel which became OPEN isn't lighting, but other LED parallel is lighting.  
 Then, Output boosts up to the over voltage protection voltage 25.5V because LED terminal can be 0V.  
 After the over voltage protection is detected, LED terminal of 0V isn't cut from feedback loop.  
 Then, Output voltage will become normal voltage automatically.
- 2) When LED short-circuited in the plural  
 All LED continue to be turned on, unless LED terminal voltage become more than "LED terminal over voltage protection (11.5V)".  
 When it was more than 11.5V, the line which short-circuited is only turned on, and LED current of other lines decrease or turn off.
- 3) When Schottky diode came off  
 All LED aren't turned on.  
 Also, IC isn't destroyed because boost operating stops by the Schottky diode coming off protected function.
- 4) When an output capacitor short.  
 All LED aren't turned on.  
 And, an IC isn't destroyed because boost stops by the SBD open protection function.  
 But, big electric current occurs, and a coil or SBD is likely to destroy it because the route of the GND short circuit of the power supply → coil → output capacitor occurs.
- 5) When the resistance to connect it to the ISET terminal short,  
 All LED aren't turned on.  
 Because LED current limit works, all current drivers stop, and DC/DC maintains boost under the state without load.  
 And, it is returned in a state of normality by canceling a state of short.

**Start Control and Select Constant Current Driver**

BD6586MUV can control the start conditions by EN1, 2 and PWM terminals, and sets 0.4V or below EN1, 2 terminals, so IC can power off. EN1, 2 and PWM power on at more than 1.4V, constant current can select ON/OFF by the combination of EN as shown below table.

When there is unused constant current driver, unused LED terminal is set "OPEN".

Enable			Constant current driver				IC POWER
EN1	EN2	PWM	LED1	LED2	LED3	LED4	
H	H	H	OFF	ON	ON	OFF	ON
L	H	H	OFF	ON	ON	ON	ON
H	L	H	ON	ON	ON	ON	ON
L	L	H	OFF	OFF	OFF	OFF	OFF
H	H	L	OFF	OFF	OFF	OFF	ON
L	H	L	OFF	OFF	OFF	OFF	ON
H	L	L	OFF	OFF	OFF	OFF	ON
L	L	L	OFF	OFF	OFF	OFF	OFF

**Control Signal Input Timing**

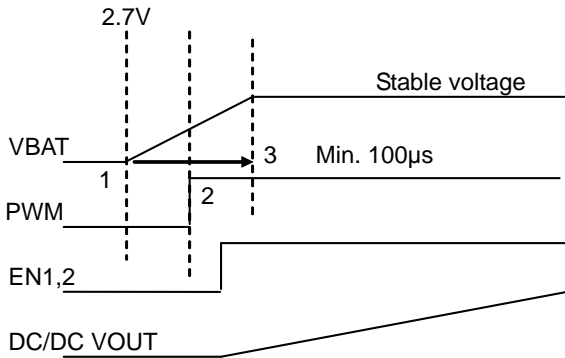

Figure 5. control Signal timing

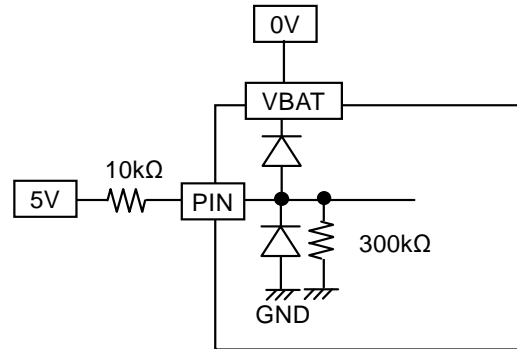

Figure 6. Voltage with a control sign higher than VBAT Example corresponding to application of conditions

In case you input control signs, such as EN1, EN2 and PWM in the condition that the standup of supply voltage (VBAT) is not completed, be careful of the following point.

Input each control signal after VBAT exceeds 2.7V.

Please do not input each control sign until VBAT exceeds HI voltage of EN1, EN2 and PWM.

When you input HI voltage to EN1, EN2 and PWM during the standup of VBAT, please give Min.100µs as the standup time of VBAT from stable voltage to 2.7V.

There is no timing limitation at each input signal of EN1, EN2 and PWM.

If each control sign changes into a condition lower than VBAT in (1) and (2), it goes via the ESD custody diode by the side of VBAT of each terminal. A power supply is supplied to VBAT and there is a possibility of malfunctioning. Moreover, when the entrance current to the terminal exceeds 50mA, it has possibility to damage the LSI. In order to avoid this condition, as shown in the above figure, please insert about 10kΩ in a signal line, and apply current qualification.

**LED Current Setting Range**

LED current can set up Normal current by resistance value (RISET) connecting to ISET voltage.

Setting of each LED current is given as shown below.

$$\text{Normal current} = 20\text{mA}(24\text{k}\Omega/\text{RISET})$$

Also, Normal current setting range is 10mA to 25mA.

LED current becomes a leak current MAX 2µA at OFF setting.

ISET Normal current setting example

RISETH	LED current	RISETH	LED current
24kΩ (E24)	20mA	28kΩ (E96)	17.1mA
25.5 kΩ (E96)	18.8mA	30kΩ (E24)	16.0mA
27 kΩ (E12)	17.8mA	33kΩ (E6)	14.5mA

**Brightness Control**

There are two dimming method is available, first method is analog dimming that apply analog voltage to ISETH terminal, and second method is PWM control via digital dimming of EN1, EN2 PWM terminals or PWM. Because each method has the different merit, please choose a suitable method for the application of use.

Refer to Figure 25 for the analog dimming.

Two techniques can be used as digital dimming by the PWM control. One is PWM control of current driver, the other is PWM control of power control.

As these two characteristics are shown in the below, selects to PWM control process comply with application.

- Efficiency emphasis in the low brightness which has an influence with the battery life → 2) Power control PWM control
- LED current dispersion emphasis in the PWM brightness control → 1) Current driver PWM control

(Reference)

PWM regulation process	Efficiency of LED current 0.2mA (PWM Duty=1%)	PWM frequency 200Hz Low Duty
Current driver	60%	0.1%
Power control	94%	0.6%

1)Current driver PWM control is controlled by providing PWM signal to PWM terminal, as it is shown Figure 7.

The current set up with ISET is chosen as the H section of PWM and the current is off as the L section. Therefore, the average LED current is increasing in proportion to duty cycle of PWM signal. This method that it lets internal circuit and DC/DC to work, because it becomes to switch the driver, the current tolerance is a few when the PWM brightness is adjusted, it makes it possible to brightness control until 20µs (MIN0.4% at 200Hz). And, don't use for the brightness control, because effect of ISET changeover is big under 20µs ON time and under 20µs OFF time. There is no effect of ON/OFF changeover at 0% and 100%, so there is no problem on use. Typical PWM frequency is 100Hz to 10kHz.

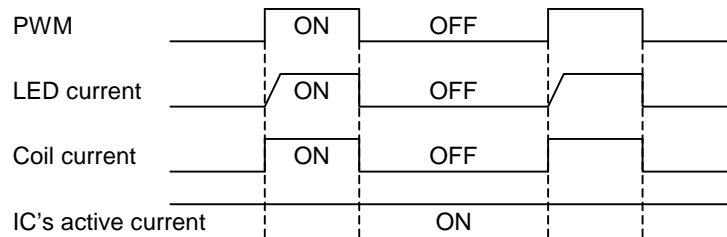

Figure 7. Current driver PWM control

2)Power control PWM control is controlled by providing PWM signal to EN1, EN2 as it is shown Figure 8. The current setting set up with PWM logic is chosen as the H section and the current is off as the L section. Therefore, the average LED current is increasing in proportion to duty cycle of EN1, EN2 signal. This method is, because IC can be power-off at off-time, the consumption current can be suppress, and the high efficiency can be available, so it makes it possible to brightness control until 50µs (MIN1% at 200Hz). And, don't use for the brightness control, because effect of power ON/OFF time changeover is big under 50µs ON time and under 50µs OFF time. There is no effect of ON/OFF changeover at 0% and 100%, so there is no problem on use. Typical PWM frequency is 100Hz to 1kHz.

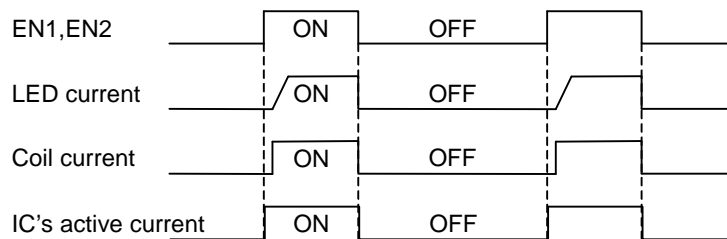

Figure 8. Power control PWM control

**The Separations of the IC Power Supply and Coil Power Supply**

This IC can work in separating the power source in both IC power supply and coil power supply. With this application, it can obtain that decrease of IC power consumption, and the applied voltage exceeds IC rating 5.5V.

That application is shown in below Figure 9. The higher voltage source is applied to the power source of coil that is connected from an adapter etc. Next, the IC power supply is connected with a different coil power supply.

When the coil power supply is applied, it is no any problem even though IC power supply is the state of 0V. Although IC power supply is set to 0V, pull-down resistance is arranged for the power off which cuts off the leak route from coil power supply in IC inside, the leak route is cut off. And, there is no power on-off sequence of coil power supply and IC power supply.

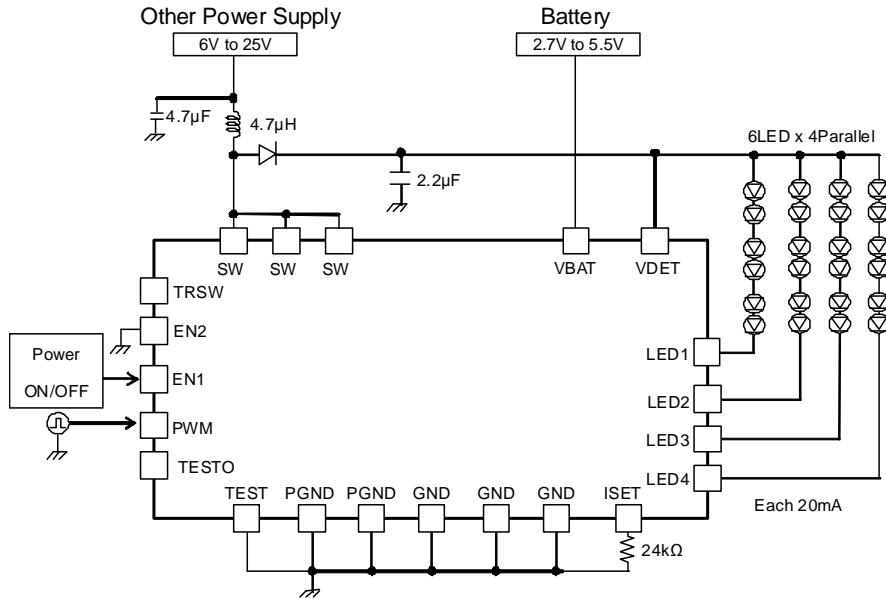

Figure 9. Each battery and coil power supply

**The Coil Selection**

The DC/DC is designed by more than 4.7µH. When L value sets to a lower value, it is possibility that the specific sub-harmonic oscillation of current mode DC / DC will be happened.

Please do not let L value to 3.3µH or below.

And, L value increases, the phase margin of DC / DC becomes to zero. Please enlarge the output capacitor value when you increase L value.

Example)

4.7µH	=	output capacitor	2.2µF/50V	1pcs
6.8µH	=	output capacitor	2.2µF/50V	2pcs
10µH	=	output capacitor	2.2µF/50V	3pcs

This value is just examples, please made sure the final judgment is under an enough evaluation.

**The Adjustment of the Switching Wave Form**

A switching wave form between the coil and the switch terminal can be adjusted by connecting a capacitor to TRSW. Switching noise can be restrained though efficiency is made to decrease by connecting a capacitor. Decide capacity value after the enough evaluation when you adjust switching noise.

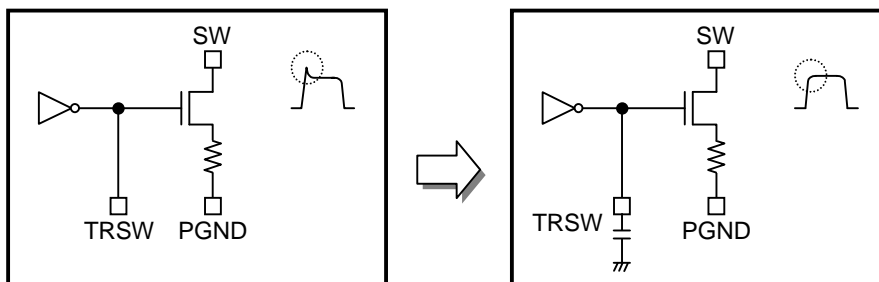

Figure 10. The adjustment of the switching wave form



### PCB Layout

In order to make the most of the performance of this IC, its layout pattern is very important. Characteristics such as efficiency and ripple and the likes change greatly with layout patterns, which please note carefully.

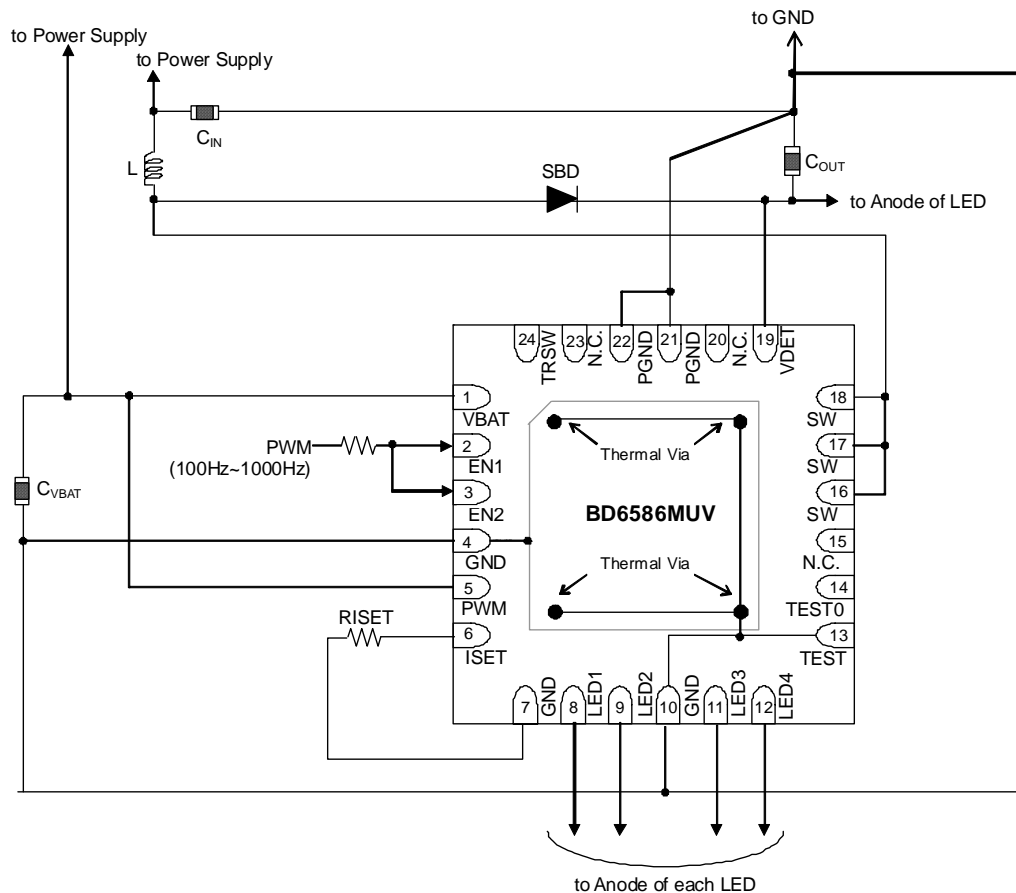

Figure 11. PCB Layout

Connect the input bypass capacitor  $C_{IN}$  nearest to coil  $L$  and  $PGND$ , as shown in the upper diagram.

Ripple of a power supply is smoothed by  $C_{IN}$  and connect stable voltage to  $VBAT$  terminal by the low resistance. Thereby, the input voltage ripple of the IC can be reduced.

Connect  $C_{VBAT}$  nearest to between the  $VBAT$  terminal and  $GND$  (4 pin) as shown in the upper diagram when you can't be wired by the low resistance from  $C_{IN}$  to  $VBAT$  pin

Connect schottky barrier diode  $SBD$  of the regulator nearest to between coil  $L$  and  $SW$  terminal.

And connect output capacitor  $C_{OUT}$  nearest to between  $C_{IN}$  and  $GND$  pin. Thereby, the output voltage ripple of the IC can be reduced.

$GND$  terminal (4,7,10 pin) is connected inside the IC, and it is  $GND$  of the block except switching and a transistor.

A current drive performance may be restricted by influence of a noise, if  $PGND$  which is not smooth connected to  $GND$ .

A  $GND$  terminal is connected to the stable  $GND$  plane. And connect it to a  $GND$  plane after smoothing  $PGND$  by  $C_{IN}$  and  $C_{OUT}$ .  $GND$  and  $PGND$  are separated inside IC.

And connect it to a  $GND$  plane after smoothing  $PGND$  by  $C_{IN}$  and  $C_{OUT}$ .

Connect the heat sink of IC to a  $GND$  plane through Thermal Via. And Connect with the largest possible pattern.

It is satisfactory even if it connects with the  $GND$  terminal of IC.

Connect LED current setting resistor  $R_{ISET}$  nearest to  $ISET$  pin. There is possibility to oscillate when capacity is added to  $ISET$  terminal, so pay attention that capacity isn't added. And,  $R_{ISET}$  of  $GND$  side must be wired directly to  $GND$ (7pin) pin.

When those pins are not connected directly near the chip, influence is given to the performance of  $BD6586MUV$ , and may limit the current drive performance. As for the wire to the inductor, make its resistance component small so as to reduce electric power consumption and increase the entire efficiency.

A layout pattern in consideration of these is shown in page 10.

Recommended PCB Layout Pattern

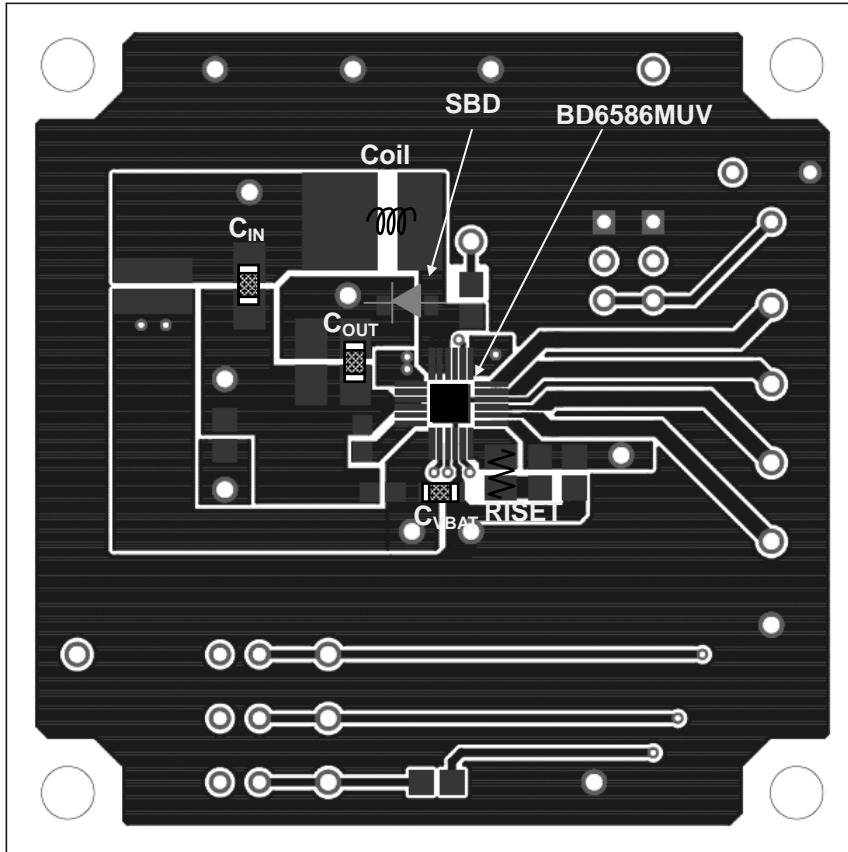

Figure 12. Frontal surface <Top view>

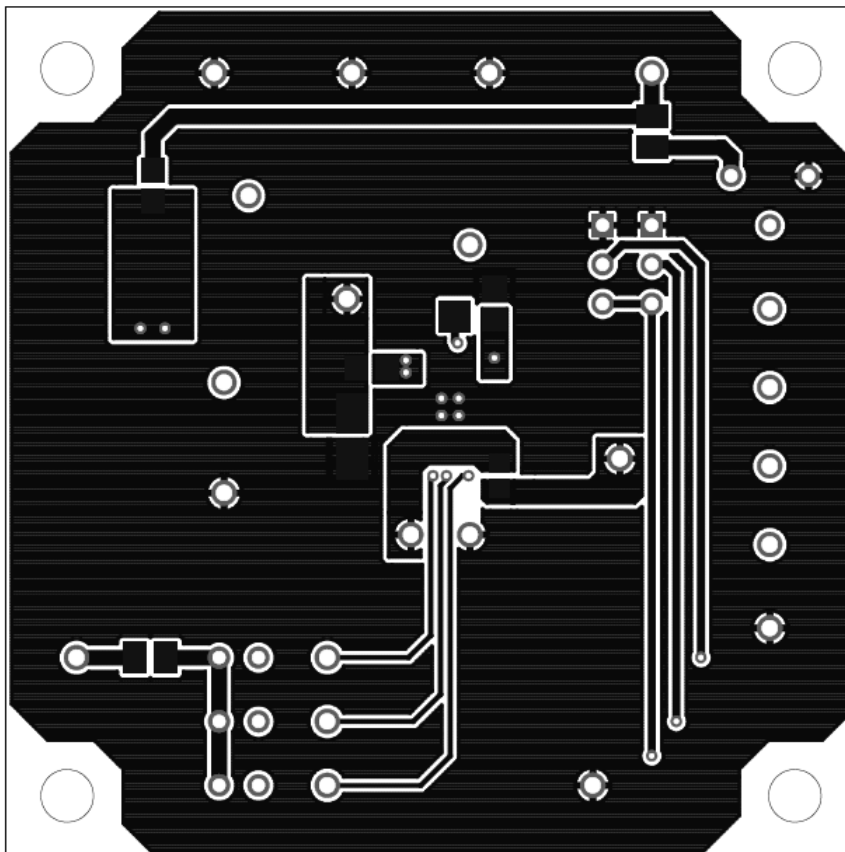

Figure 13. Rear surface <Top view>

**Selection of External Parts**

Recommended external parts are as shown below.

When to use other parts than these, select the following equivalent parts.

## •Coil

Value	Manufacturer	Product number	Size			DC current (mA)	DCR (Ω)
			Vertical	Horizontal	Height (MAX)		
4.7μH	TOKO	A915AY-4R7M	5.2	5.2	3.0	1870	0.045
4.7μH	TOKO	B1015AS-4R7M	8.4	8.3	4.0	3300	0.038
4.7μH	TOKO	A1101AS-4R7M	4.1	4.1	1.2	1400	0.115
4.7μH	TDK	LTF5022T-4R7N2R0	5.0	5.2	2.2	2000	0.073
10μH	TDK	LTF5022T-100M1R4	5.0	5.2	2.2	1400	0.140
4.7μH	TDK	VLP6810T-4R7M1R6	6.3	6.8	1.0	1600	0.167
10μH	TDK	VLP6810T-100M1R1	6.3	6.8	1.0	1100	0.350

## •Capacitor

Value	Pressure	Manufacturer	Product number	Size			TC	Cap Tolerance
				Vertical	Horizontal	Height		
<b>[ Power supply capacitor ]</b>								
4.7μF	25V	MURATA	GRM319B31E475K	3.2	1.6	0.85±0.1	B	+/-10%
4.7μF	25V	MURATA	GRM21BR61E475K	2.0	1.25	1.25±0.1	X5R	+/-10%
1μF	10V	MURATA	GRM188B11A105K	1.6	0.8	0.8±0.1	B	+/-10%
4.7μF	10V	MURATA	GRM219B31A475K	2.0	1.25	0.85±0.1	B	+/-10%
<b>[ Output capacitor ]</b>								
1μF	35V	MURATA	GRM219B3YA105K	2.0	1.25	0.85±0.1	B	+/-10%
1μF	50V	MURATA	GRM31MB31H105K	3.2	1.6	1.15±0.1	B	+/-10%
1μF	50V	MURATA	GRM21BB31H105K	2.0	1.25	1.25±0.1	B	+/-10%
2.2μF	50V	MURATA	GRM31CB31H225K	3.2	1.6	1.6±0.2	B	+/-10%

## •Resistor

Value	Tolerance	Manufacturer	Product number	Size		
				Vertical	Horizontal	Height
<b>[ Resistor for LED current decision &lt;ISET pin&gt; ]</b>						
24kΩ	±0.5%	ROHM	MCR006YZPD243	0.6	0.3	0.23±0.03

## •SBD

Pressure	Manufacturer	Product number	Size		
			Vertical	Horizontal	Height
60V	ROHM	RB160M-60	3.5	1.6	0.8±0.1

The coil is the part that is most influential to efficiency. Select the coil whose direct current resistor (DCR) and current - inductance characteristic is excellent. BD6586MUV is designed for the inductance value of 4.7μH. Don't use the inductance value less than 2.2μH. Select a capacitor of ceramic type with excellent frequency and temperature characteristics.

Further, select Capacitor to be used with small direct current resistance, and pay sufficient attention to the layout pattern shown in Page 10.

**Attention Point of PCB Layout**

In PCB layout design, the wiring of power supply line should be low Impedance, and put the bypass capacitor if necessary. Especially the wiring impedance must be lower around the DC/DC converter.

**About Heat Loss**

In heat design, operate the DC/DC converter in the following condition.

(The following temperature is a guarantee temperature, so consider the margin.)

1. Periphery temperature Ta must be less than 85 .
2. The loss of IC must be less than dissipation Pd.

**Application Example**

- LED current setting controlled ISET resistor.  
 19.6kΩ : 24.5mA  
 24kΩ : 20mA  
 30kΩ : 16mA  
 33kΩ : 14.5mA
- Brightness control  
 Please input PWM pulse from EN1, EN2 or PWM terminal.  
 Please refer electrical function page 7.

**7 inch panel**

s

Figure 14. 6 series×4 parallel, LED current 20mA setting  
 Power control PWM application

**5inch panel**

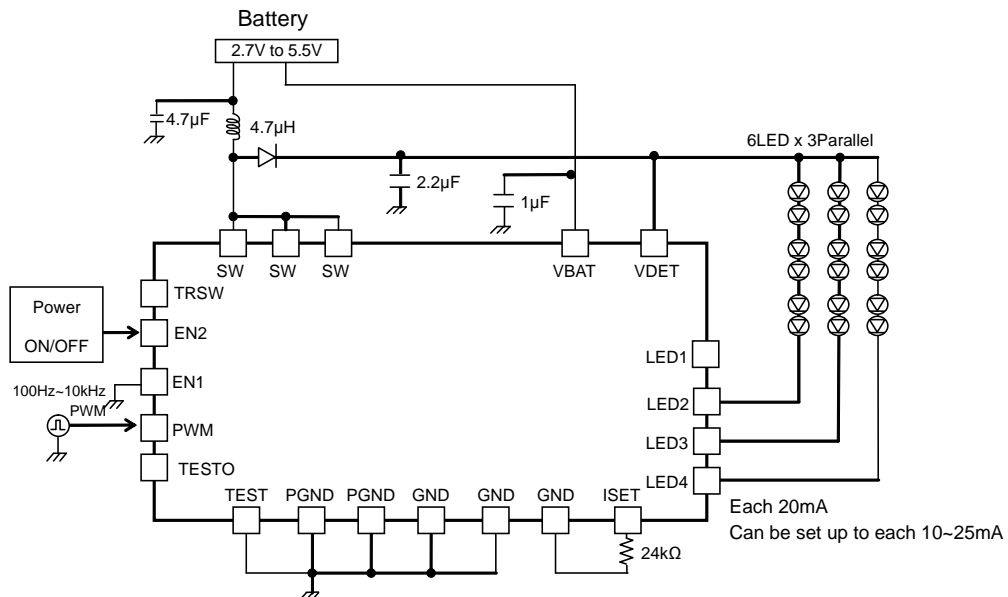

Figure 15. 6 series×3 parallel, LED current 20mA setting  
 Current driver PWM application

- LED current setting controlled ISET resistor.  
 19.6kΩ : 24.5mA  
 24kΩ : 20mA  
 30kΩ : 16mA  
 33kΩ : 14.5mA
- Brightness control  
 Please input PWM pulse from EN1, EN2 or PWM terminal.  
 Please refer electrical function page 7.

**5 inch panel**

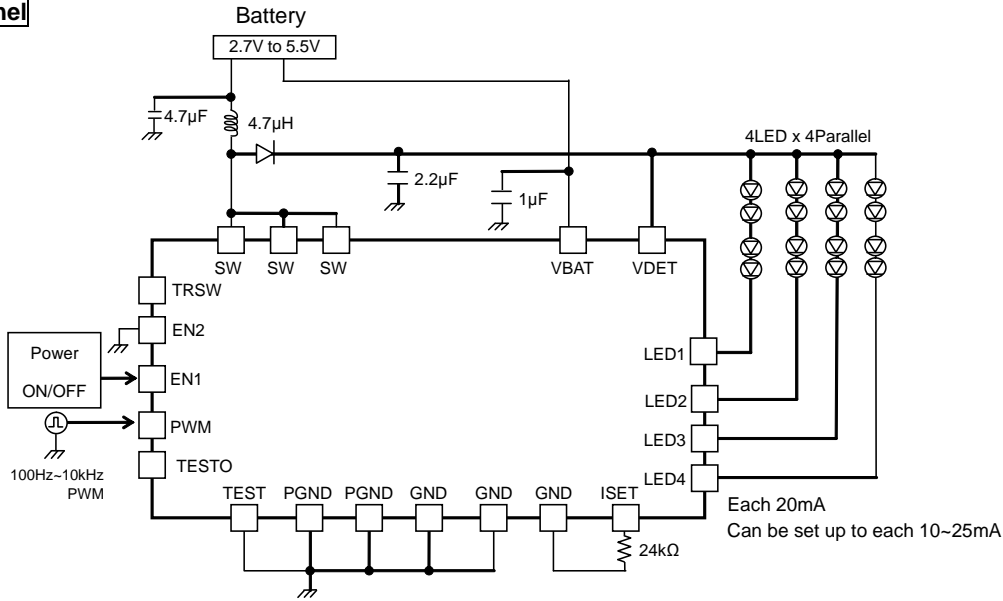

Figure 16. 4 seriesx4 parallel, LED current 20mA setting  
Current driver PWM application

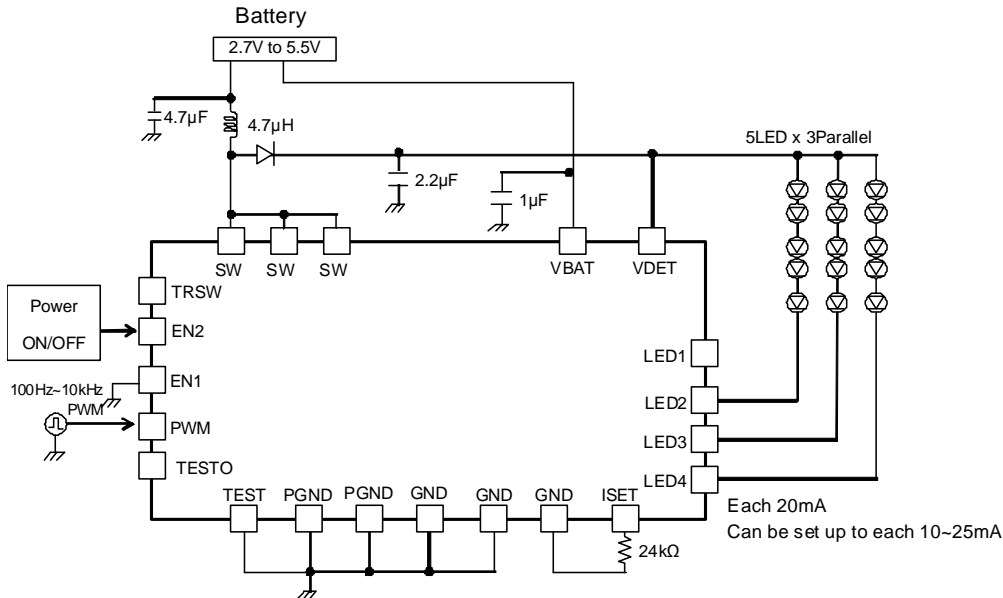

Figure 17. 5 seriesx3 parallel, LED current 20mA setting  
Current driver PWM application

- LED current setting controlled ISET resistor.  
 19.6kΩ : 24.5mA  
 24kΩ : 20mA  
 30kΩ : 16mA  
 33kΩ : 14.5mA
- Brightness control  
 Please input PWM pulse from EN1, EN2 or PWM terminal.  
 Please refer electrical function page 7.

**Less than 5 inch panel**

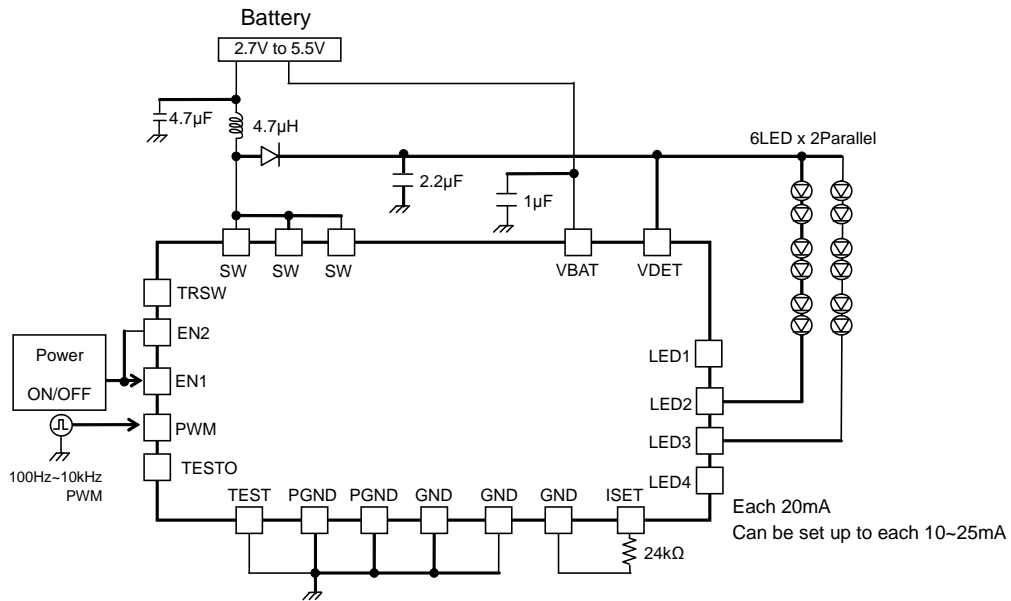

Figure 18. 6 seriesx2 parallel, LED current 20mA setting  
Current driver PWM application

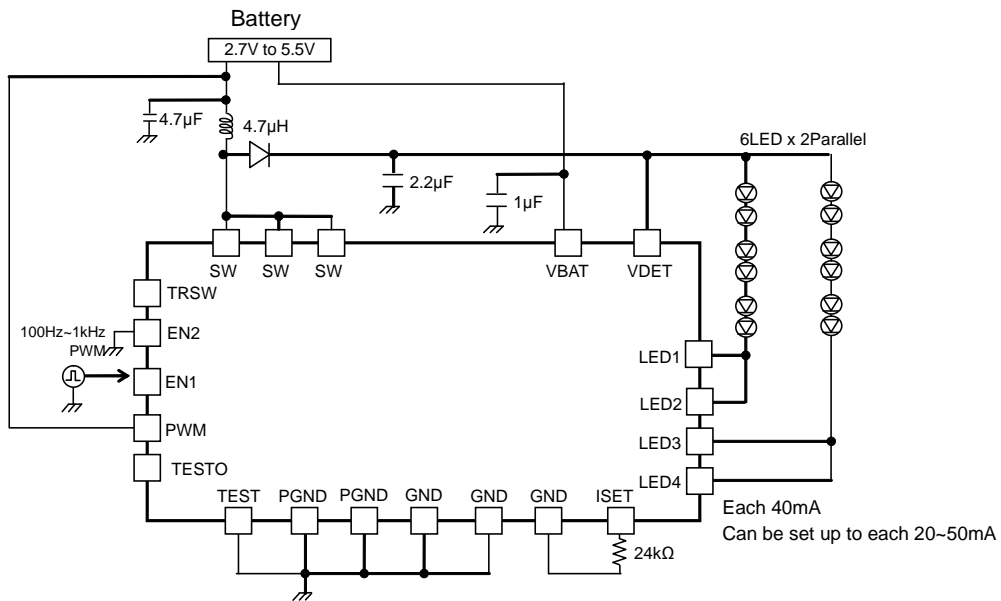

Figure 19. 6 seriesx2 parallel, LED current 40mA setting  
Power control PWM application

- LED current setting controlled ISET resistor.  
 19.6kΩ : 24.5mA  
 24kΩ : 20mA  
 30kΩ : 16mA  
 33kΩ : 14.5mA
- Brightness control  
 Please input PWM pulse from EN1, EN2 or PWM terminal.  
 Please refer electrical function page 7.

**Less than 5 inch panel**

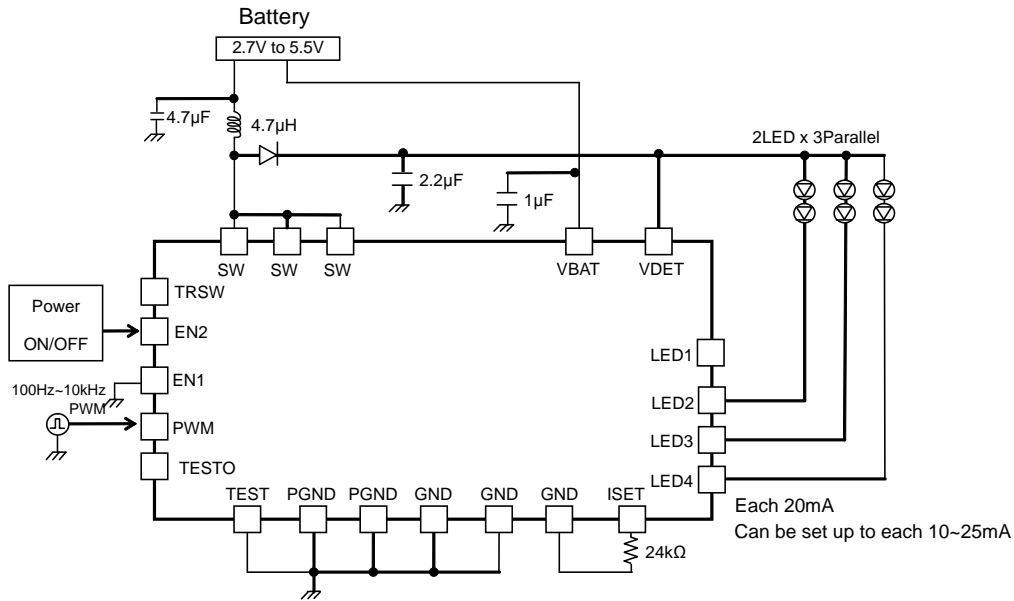

Figure 20. 2 seriesx3 parallel, LED current 20mA setting  
Current driver PWM application

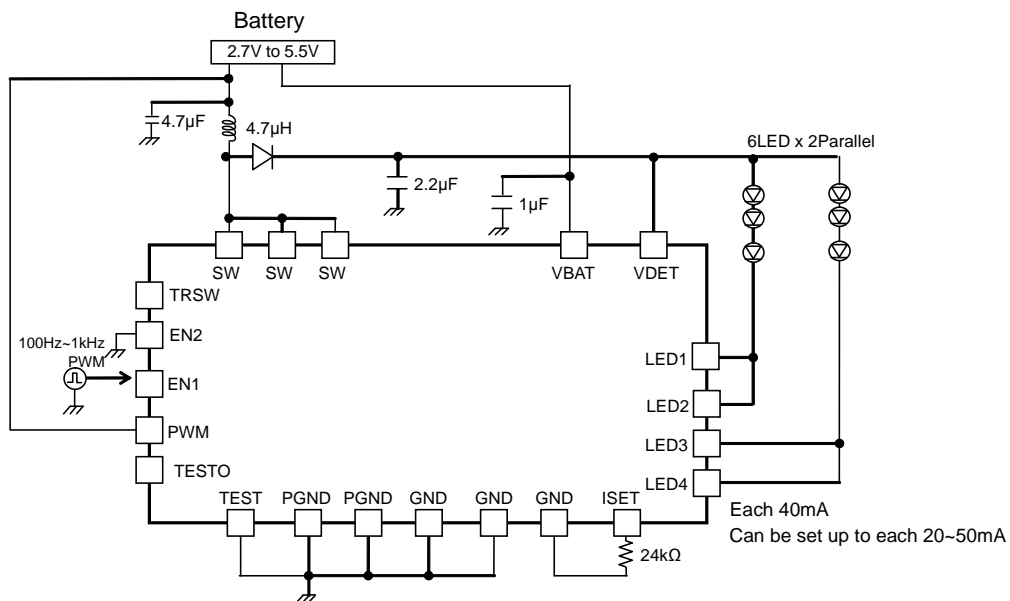

Figure 21. 3 seriesx2 parallel, LED current 40mA setting  
Power control PWM application

- LED current setting controlled ISET resistor.  
 19.6kΩ : 24.5mA  
 24kΩ : 20mA  
 30kΩ : 16mA  
 33kΩ : 14.5mA
- Brightness control  
 Please input PWM pulse from EN1, EN2 or PWM terminal.  
 Please refer electrical function page 7.

**For big current LED**

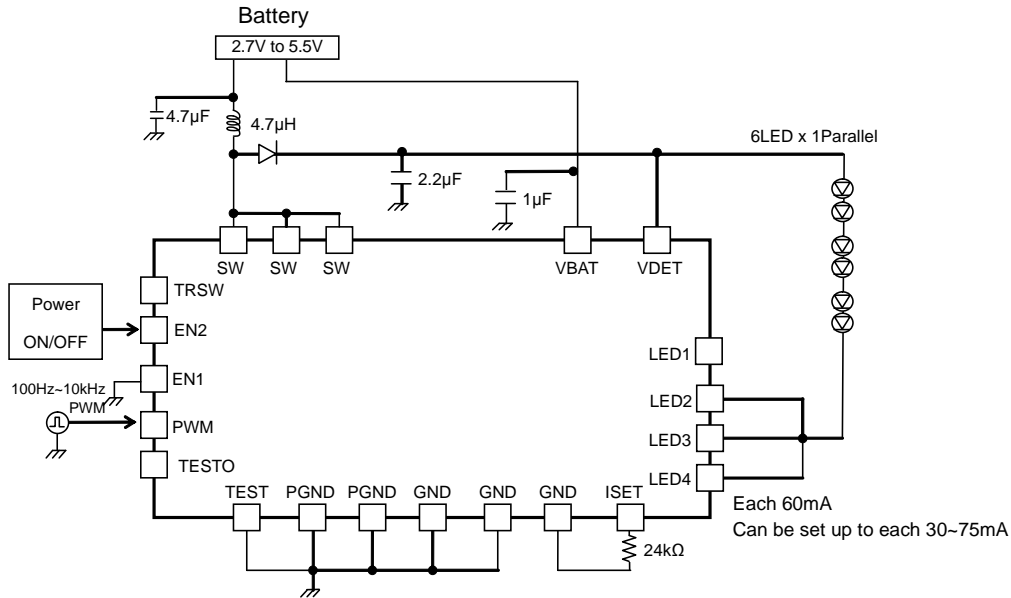

Figure 22. 6 series×1 parallel, LED current 60mA setting  
 Current driver PWM application

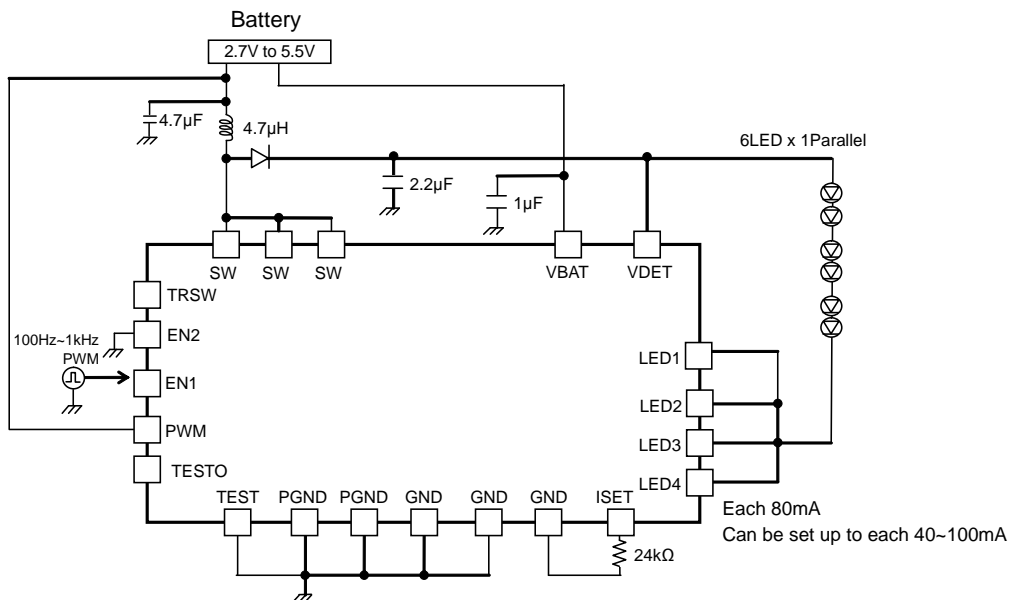

Figure 23. 6 series×1 parallel, LED current 80mA setting  
 Power control PWM application



- LED current setting controlled ISET resistor.  
 19.6kΩ : 24.5mA  
 24kΩ : 20mA  
 30kΩ : 16mA  
 33kΩ : 14.5mA
- Brightness control  
 Please input PWM pulse from EN1, EN2 or PWM terminal.  
 Please refer electrical function page 7.

**For the application of 7V and more**

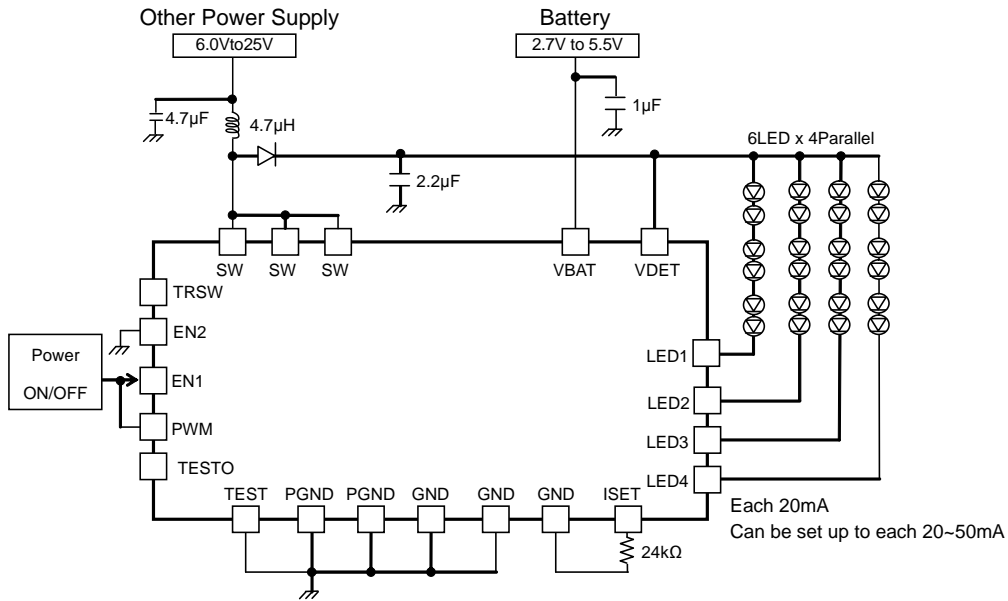
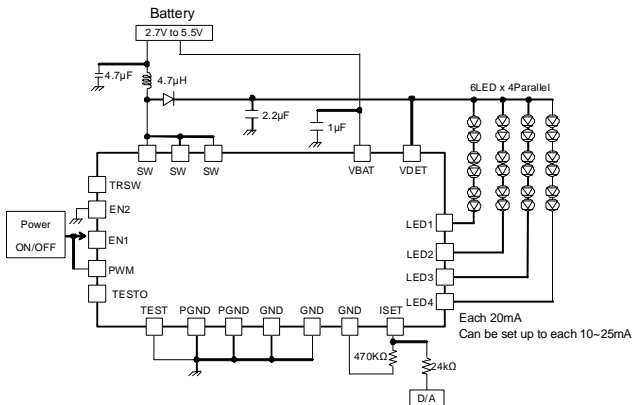

Figure 24. 6 seriesx4 parallel, LED current 20mA setting Power control PWM application

**Analog Style Optical Application**

Control LED current to charged D/A voltage.  
 Show application example and typ control.  
 Please decide final value after you evaluated application, characteristic.



D/A	LED current
0.05V	19.4mA
0.2V	14.4mA
0.4V	7.7mA
0.5V	4.4mA
0.6V	1.0mA
0.7V	0mA

$$\text{LED current} = \left( \frac{\text{ISET voltage}}{470\text{k}\Omega} + \frac{\text{ISET voltage} - \text{D/A}}{24\text{k}\Omega} \right) \times 800$$

$$\text{typ LED current} = \left( \frac{0.6\text{V}}{470\text{k}\Omega} + \frac{0.6\text{V} - \text{D/A}}{24\text{k}\Omega} \right) \times 800$$

Figure 25. Analog style optical application

**Operational Notes**

- (1) Absolute Maximum Ratings  
An excess in the absolute maximum ratings, such as supply voltage, temperature range of operating conditions, etc., can break down devices, thus making impossible to identify breaking mode such as a short circuit or an open circuit. If any special mode exceeding the absolute maximum ratings is assumed, consideration should be given to take physical safety measures including the use of fuses, etc.
- (2) Operating Condition  
These conditions represent a range within which characteristics can be provided approximately as expected. The electrical characteristics are guaranteed under the conditions of each parameter.
- (3) Reverse connection of power supply connector  
The reverse connection of power supply connector can break down ICs. Take protective measures against the breakdown due to the reverse connection, such as mounting an external diode between the power supply and the IC's power supply terminal.
- (4) Power supply line  
Design PCB pattern to provide low impedance for the wiring between the power supply and the GND lines. In this regard, for the digital block power supply and the analog block power supply, even though these power supplies has the same level of potential, separate the power supply pattern for the digital block from that for the analog block, thus suppressing the diffraction of digital noises to the analog block power supply resulting from impedance common to the wiring patterns. For the GND line, give consideration to design the patterns in a similar manner.  
Furthermore, for all power supply terminals to ICs, mount a capacitor between the power supply and the GND terminal. At the same time, in order to use an electrolytic capacitor, thoroughly check to be sure the characteristics of the capacitor to be used present no problem including the occurrence of capacity dropout at a low temperature, thus determining the constant.
- (5) GND voltage  
Make setting of the potential of the GND terminal so that it will be maintained at the minimum in any operating state. Furthermore, check to be sure no terminals are at a potential lower than the GND voltage including an actual electric transient.
- (6) Short circuit between terminals and erroneous mounting  
In order to mount ICs on a set PCB, pay thorough attention to the direction and offset of the ICs. Erroneous mounting can break down the ICs. Furthermore, if a short circuit occurs due to foreign matters entering between terminals or between the terminal and the power supply or the GND terminal, the ICs can break down.
- (7) Operation in strong electromagnetic field  
Be noted that using ICs in the strong electromagnetic field can malfunction them.
- (8) Inspection with set PCB  
On the inspection with the set PCB, if a capacitor is connected to a low-impedance IC terminal, the IC can suffer stress. Therefore, be sure to discharge from the set PCB by each process. Furthermore, in order to mount or dismount the set PCB to/from the jig for the inspection process, be sure to turn OFF the power supply and then mount the set PCB to the jig. After the completion of the inspection, be sure to turn OFF the power supply and then dismount it from the jig. In addition, for protection against static electricity, establish a ground for the assembly process and pay thorough attention to the transportation and the storage of the set PCB.
- (9) Input terminals  
In terms of the construction of IC, parasitic elements are inevitably formed in relation to potential. The operation of the parasitic element can cause interference with circuit operation, thus resulting in a malfunction and then breakdown of the input terminal. Therefore, pay thorough attention not to handle the input terminals, such as to apply to the input terminals a voltage lower than the GND respectively, so that any parasitic element will operate. Furthermore, do not apply a voltage to the input terminals when no power supply voltage is applied to the IC. In addition, even if the power supply voltage is applied, apply to the input terminals a voltage lower than the power supply voltage or within the guaranteed value of electrical characteristics.
- (10) Ground wiring pattern  
If small-signal GND and large-current GND are provided, It will be recommended to separate the large-current GND pattern from the small-signal GND pattern and establish a single ground at the reference point of the set PCB so that resistance to the wiring pattern and voltage fluctuations due to a large current will cause no fluctuations in voltages of the small-signal GND. Pay attention not to cause fluctuations in the GND wiring pattern of external parts as well.
- (11) External capacitor  
In order to use a ceramic capacitor as the external capacitor, determine the constant with consideration given to a degradation in the nominal capacitance due to DC bias and changes in the capacitance due to temperature, etc.
- (12) Thermal shutdown circuit (TSD)  
When junction temperatures become 175°C (typ) or higher, the thermal shutdown circuit operates and turns a switch OFF. The thermal shutdown circuit, which is aimed at isolating the LSI from thermal runaway as much as possible, is not aimed at the protection or guarantee of the LSI. Therefore, do not continuously use the LSI with this circuit operating or use the LSI assuming its operation.
- (13) Thermal design  
Perform thermal design in which there are adequate margins by taking into account the permissible dissipation (Pd) in actual states of use.
- (14) Selection of coil  
Select the low DCR inductors to decrease power loss for DC/DC converter.

Ordering Information

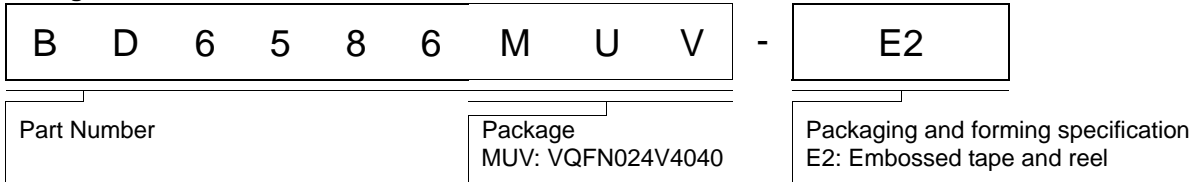

Marking Diagram

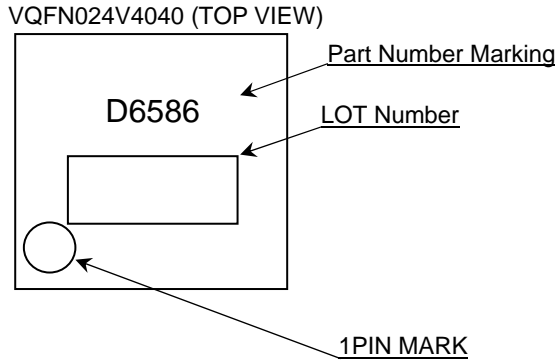

Physical Dimension Tape and Reel Information

VQFN024V4040

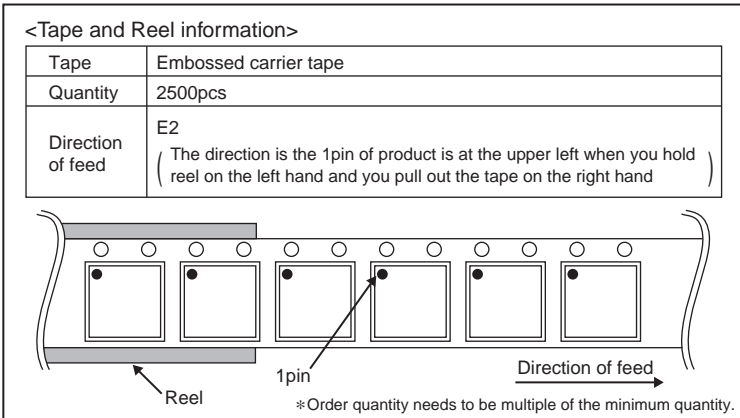
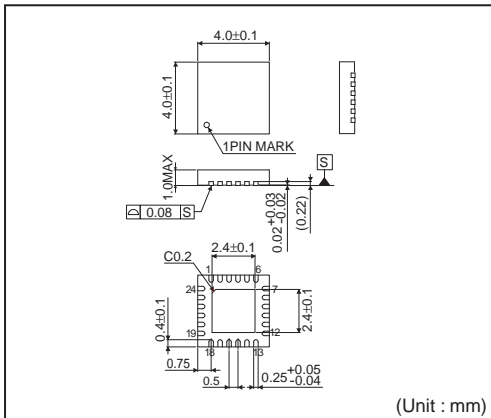

## Revision History

Date	Revision	Changes
10.Dec.2012	001	New Release

# Notice

## Precaution on using ROHM Products

- Our Products are designed and manufactured for application in ordinary electronic equipments (such as AV equipment, OA equipment, telecommunication equipment, home electronic appliances, amusement equipment, etc.). If you intend to use our Products in devices requiring extremely high reliability (such as medical equipment <sup>(Note 1)</sup>, transport equipment, traffic equipment, aircraft/spacecraft, nuclear power controllers, fuel controllers, car equipment including car accessories, safety devices, etc.) and whose malfunction or failure may cause loss of human life, bodily injury or serious damage to property ("Specific Applications"), please consult with the ROHM sales representative in advance. Unless otherwise agreed in writing by ROHM in advance, ROHM shall not be in any way responsible or liable for any damages, expenses or losses incurred by you or third parties arising from the use of any ROHM's Products for Specific Applications.

(Note1) Medical Equipment Classification of the Specific Applications

JAPAN	USA	EU	CHINA
CLASS III	CLASS III	CLASS II b	CLASS III
CLASS IV		CLASS III	

- ROHM designs and manufactures its Products subject to strict quality control system. However, semiconductor products can fail or malfunction at a certain rate. Please be sure to implement, at your own responsibilities, adequate safety measures including but not limited to fail-safe design against the physical injury, damage to any property, which a failure or malfunction of our Products may cause. The following are examples of safety measures:
  - Installation of protection circuits or other protective devices to improve system safety
  - Installation of redundant circuits to reduce the impact of single or multiple circuit failure
- Our Products are designed and manufactured for use under standard conditions and not under any special or extraordinary environments or conditions, as exemplified below. Accordingly, ROHM shall not be in any way responsible or liable for any damages, expenses or losses arising from the use of any ROHM's Products under any special or extraordinary environments or conditions. If you intend to use our Products under any special or extraordinary environments or conditions (as exemplified below), your independent verification and confirmation of product performance, reliability, etc. prior to use, must be necessary:
  - Use of our Products in any types of liquid, including water, oils, chemicals, and organic solvents
  - Use of our Products outdoors or in places where the Products are exposed to direct sunlight or dust
  - Use of our Products in places where the Products are exposed to sea wind or corrosive gases, including Cl<sub>2</sub>, H<sub>2</sub>S, NH<sub>3</sub>, SO<sub>2</sub>, and NO<sub>2</sub>
  - Use of our Products in places where the Products are exposed to static electricity or electromagnetic waves
  - Use of our Products in proximity to heat-producing components, plastic cords, or other flammable items
  - Sealing or coating our Products with resin or other coating materials
  - Use of our Products without cleaning residue of flux (even if you use no-clean type fluxes, cleaning residue of flux is recommended); or Washing our Products by using water or water-soluble cleaning agents for cleaning residue after soldering
  - Use of the Products in places subject to dew condensation
- The Products are not subject to radiation-proof design.
- Please verify and confirm characteristics of the final or mounted products in using the Products.
- In particular, if a transient load (a large amount of load applied in a short period of time, such as pulse. is applied, confirmation of performance characteristics after on-board mounting is strongly recommended. Avoid applying power exceeding normal rated power; exceeding the power rating under steady-state loading condition may negatively affect product performance and reliability.
- De-rate Power Dissipation (Pd) depending on Ambient temperature (Ta). When used in sealed area, confirm the actual ambient temperature.
- Confirm that operation temperature is within the specified range described in the product specification.
- ROHM shall not be in any way responsible or liable for failure induced under deviant condition from what is defined in this document.

## Precaution for Mounting / Circuit board design

- When a highly active halogenous (chlorine, bromine, etc.) flux is used, the residue of flux may negatively affect product performance and reliability.
- In principle, the reflow soldering method must be used; if flow soldering method is preferred, please consult with the ROHM representative in advance.

For details, please refer to ROHM Mounting specification

### Precautions Regarding Application Examples and External Circuits

1. If change is made to the constant of an external circuit, please allow a sufficient margin considering variations of the characteristics of the Products and external components, including transient characteristics, as well as static characteristics.
2. You agree that application notes, reference designs, and associated data and information contained in this document are presented only as guidance for Products use. Therefore, in case you use such information, you are solely responsible for it and you must exercise your own independent verification and judgment in the use of such information contained in this document. ROHM shall not be in any way responsible or liable for any damages, expenses or losses incurred by you or third parties arising from the use of such information.

### Precaution for Electrostatic

This Product is electrostatic sensitive product, which may be damaged due to electrostatic discharge. Please take proper caution in your manufacturing process and storage so that voltage exceeding the Products maximum rating will not be applied to Products. Please take special care under dry condition (e.g. Grounding of human body / equipment / solder iron, isolation from charged objects, setting of ionizer, friction prevention and temperature / humidity control).

### Precaution for Storage / Transportation

1. Product performance and soldered connections may deteriorate if the Products are stored in the places where:
  - [a] the Products are exposed to sea winds or corrosive gases, including Cl<sub>2</sub>, H<sub>2</sub>S, NH<sub>3</sub>, SO<sub>2</sub>, and NO<sub>2</sub>
  - [b] the temperature or humidity exceeds those recommended by ROHM
  - [c] the Products are exposed to direct sunshine or condensation
  - [d] the Products are exposed to high Electrostatic
2. Even under ROHM recommended storage condition, solderability of products out of recommended storage time period may be degraded. It is strongly recommended to confirm solderability before using Products of which storage time is exceeding the recommended storage time period.
3. Store / transport cartons in the correct direction, which is indicated on a carton with a symbol. Otherwise bent leads may occur due to excessive stress applied when dropping of a carton.
4. Use Products within the specified time after opening a humidity barrier bag. Baking is required before using Products of which storage time is exceeding the recommended storage time period.

### Precaution for Product Label

QR code printed on ROHM Products label is for ROHM's internal use only.

### Precaution for Disposition

When disposing Products please dispose them properly using an authorized industry waste company.

### Precaution for Foreign Exchange and Foreign Trade act

Since our Products might fall under controlled goods prescribed by the applicable foreign exchange and foreign trade act, please consult with ROHM representative in case of export.

### Precaution Regarding Intellectual Property Rights

1. All information and data including but not limited to application example contained in this document is for reference only. ROHM does not warrant that foregoing information or data will not infringe any intellectual property rights or any other rights of any third party regarding such information or data. ROHM shall not be in any way responsible or liable for infringement of any intellectual property rights or other damages arising from use of such information or data.:
2. No license, expressly or implied, is granted hereby under any intellectual property rights or other rights of ROHM or any third parties with respect to the information contained in this document.

### Other Precaution

1. This document may not be reprinted or reproduced, in whole or in part, without prior written consent of ROHM.
2. The Products may not be disassembled, converted, modified, reproduced or otherwise changed without prior written consent of ROHM.
3. In no event shall you use in any way whatsoever the Products and the related technical information contained in the Products or this document for any military purposes, including but not limited to, the development of mass-destruction weapons.
4. The proper names of companies or products described in this document are trademarks or registered trademarks of ROHM, its affiliated companies or third parties.

**General Precaution**

1. Before you use our Products, you are requested to carefully read this document and fully understand its contents. ROHM shall not be in any way responsible or liable for failure, malfunction or accident arising from the use of any ROHM's Products against warning, caution or note contained in this document.
2. All information contained in this document is current as of the issuing date and subject to change without any prior notice. Before purchasing or using ROHM's Products, please confirm the latest information with a ROHM sales representative.
3. The information contained in this document is provided on an "as is" basis and ROHM does not warrant that all information contained in this document is accurate and/or error-free. ROHM shall not be in any way responsible or liable for any damages, expenses or losses incurred by you or third parties resulting from inaccuracy or errors of or concerning such information.

# Mouser Electronics

Authorized Distributor

Click to View Pricing, Inventory, Delivery & Lifecycle Information:

[ROHM Semiconductor:](#)

[BD6586MUV-E2](#)