

EAC series

EAC -10 -472 -□

① ② ③ ④

- ① Model Name
- ② Rated Current
- ③ Line to ground capacitor code: See table 1.1.

table 1.1 Line to ground capacitor code

Code	Leakage Current (Input 125/250V 60Hz)	Line to ground capacitor (nominal value)
681	75.5 μ A/150 μ A max	680pF
102	0.13mA/0.25mA max	1000pF
222	0.25mA/0.5 mA max	2200pF
332	0.38mA/0.75mA max	3300pF
472	0.5 mA/1.0 mA max	4700pF

* When the line to ground capacitor code is different, the attenuation characteristic is different.

- ④ Options
- D: DIN rail installation type

* The dimensions change when the option is set. Refer to External view.

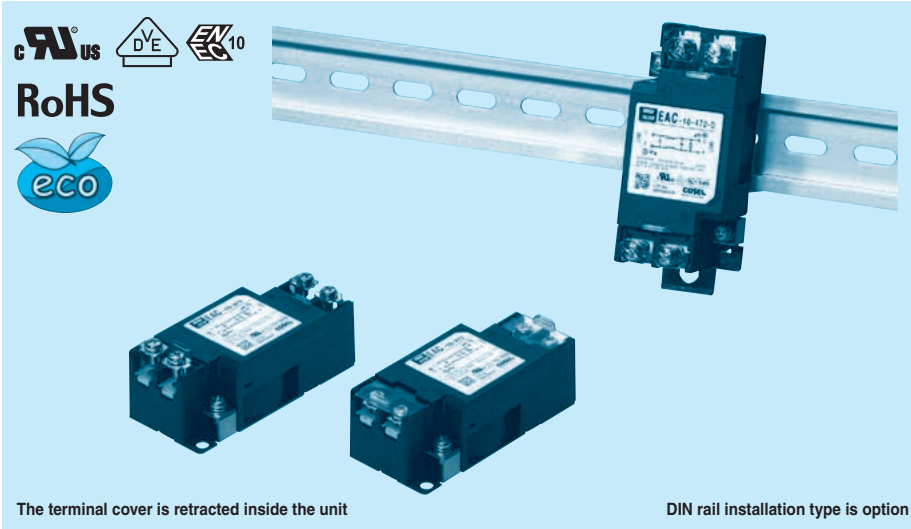

The terminal cover is retracted inside the unit

DIN rail installation type is option

Features of EAC series

Small, common mode EMI/EMC Filters in 150kHz to 1MHz(1-Stage filter)

- Single Phase 250 VAC
 - Small-size
 - Quick and easy push-down terminal
- Just connect the wires, push-down and tighten the screws with a screwdriver**

Specifications

No.	Items	EAC-03-472	EAC-06-472	EAC-10-472	EAC-16-472	EAC-20-472	EAC-30-472
1	Rated Voltage[V]	AC 1 ϕ 250 / DC250					
2	Rated Current[A]	3	6	10	16	20	30
3	Test Voltage (Terminal-Mounting Plate)	2,500 VAC (Cutoff Current = 20mA), 1minute at room temperature and humidity					
4	Isolation Resistance (Terminal-Mounting Plate)	500 VDC 500M Ω min at room temperature and humidity					
5	Leakage current 125/250V 60Hz	0.5mA/1.0mA max					
6	DC resistance	180m Ω max	110m Ω max	40m Ω max	20m Ω max	10m Ω max	6m Ω max
7	Safety agency approval temperatures	-25 to +85 $^{\circ}$ C (Refer to Derating Curve)					
8	Operating temperature	-40 to +85 $^{\circ}$ C (Refer to Derating Curve)					
9	Operating humidity	20 to 95%RH (Non condensing)					
10	Storage temperature/humidity	-40 to +85 $^{\circ}$ C/20 to 95%RH (Non condensing)					
11	Vibration	10 to 55Hz, 19.6m/s 2 (2G), 3min. Period, 1hour each X, Y and Z axis					
12	Impact	196.1m/s 2 (20G), 11ms Once each X, Y and Z axis					
13	Safety agency approvals	UL1283, CSA C22.2 No.8 (C-UL), DIN EN60939 VDE0565 Teil3-1, ENEC (At only AC input)					
14	Case size (without projection) /Weight	39X30X85 mm [1.54X1.18X3.35 inches] (W X H X D) /170g max (Option : -D refer to external view)					

Circuit Diagram

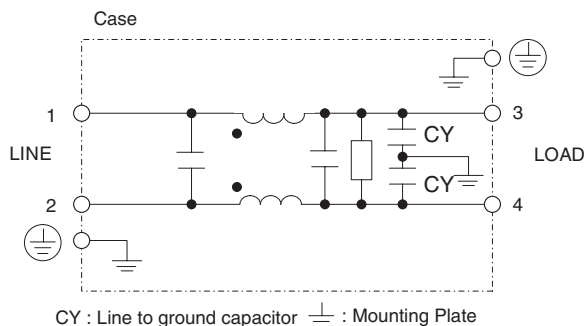

Derating Curve

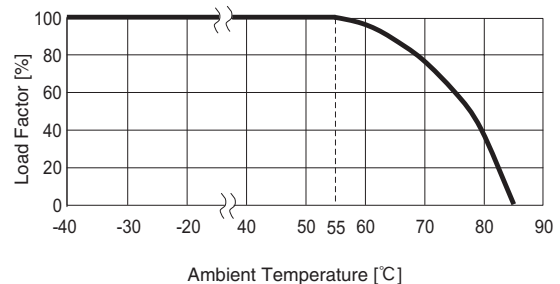

External view

This product is shipped in the following condition, because it is equipped with push-down terminals.

- ① The terminal cover is retracted inside the unit.
- ② The screws for connecting the terminals are held in the up right position.

Standard Type

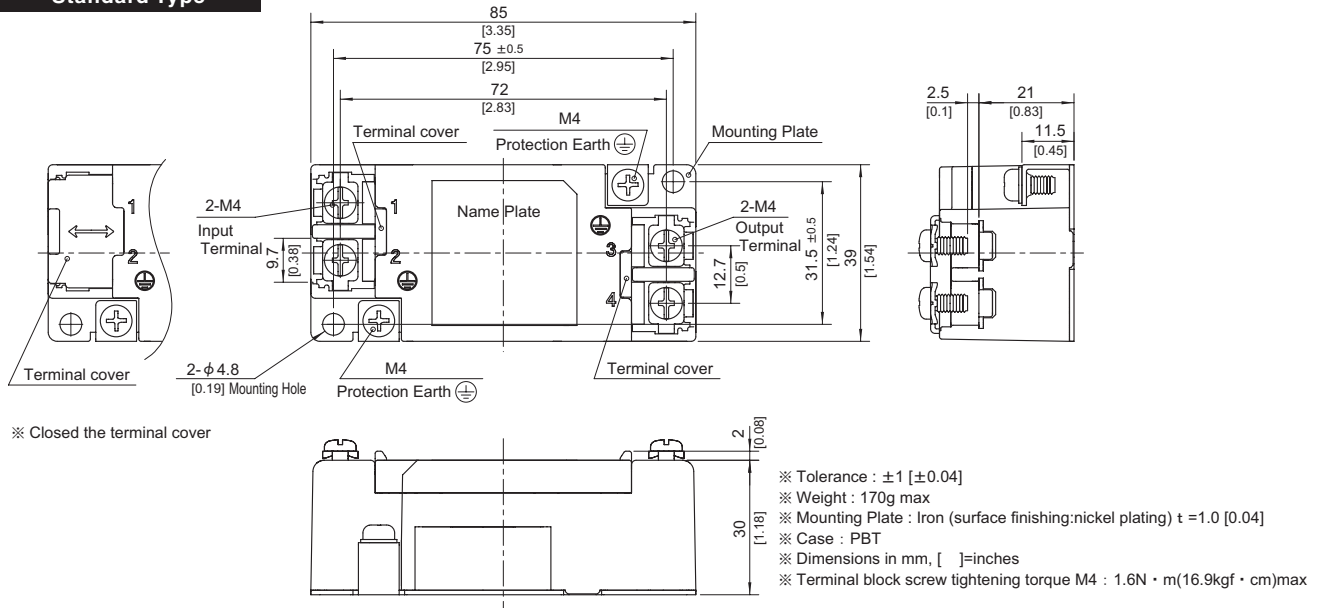

DIN rail installation Type

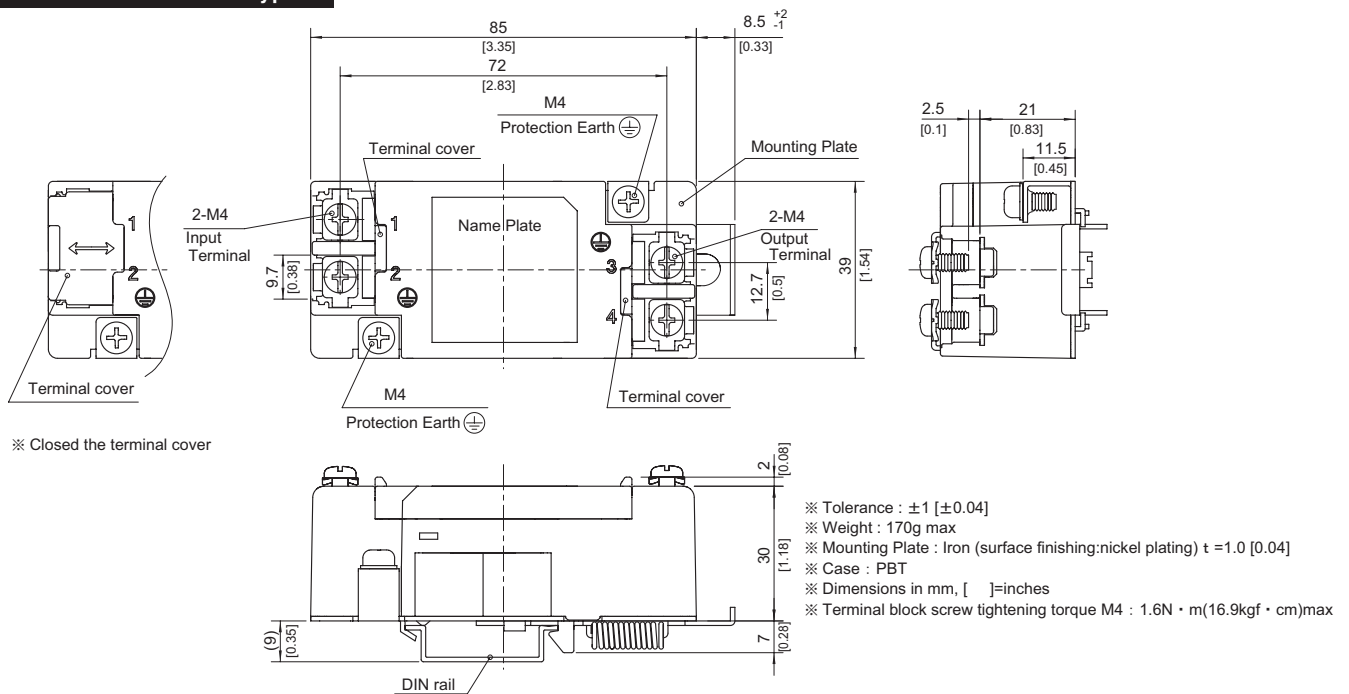

■ Note when installing the EMI/EMC Filter on a DIN rail.

When the EMI/EMC Filter is grounded through the DIN rail, the proper noise attenuation may not be achieved.

Be sure to connect the protection earth (PE) of the EMI/EMC Filter body to the earth.

It can connect the ground to either one only.

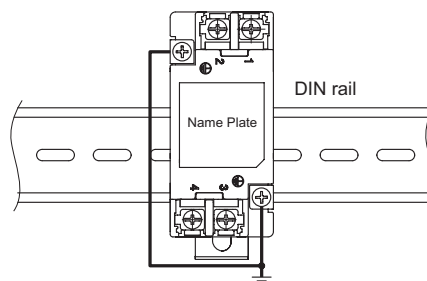

Mouser Electronics

Authorized Distributor

Click to View Pricing, Inventory, Delivery & Lifecycle Information:

Cosel:

[EAC-30-332-D](#) [EAC-30-472](#) [EAC-30-472-D](#) [EAC-30-681](#) [EAC-30-681-D](#) [EAC-20-681-D](#) [EAC-30-102](#) [EAC-30-102-D](#)
[EAC-30-222](#) [EAC-30-222-D](#) [EAC-30-332](#) [EAC-20-222-D](#) [EAC-20-332](#) [EAC-20-332-D](#) [EAC-20-472](#) [EAC-20-472-D](#)
[EAC-20-681](#) [EAC-16-472-D](#) [EAC-16-681](#) [EAC-16-681-D](#) [EAC-20-102](#) [EAC-20-102-D](#) [EAC-20-222](#) [EAC-16-102-D](#)
[EAC-16-222](#) [EAC-16-222-D](#) [EAC-16-332](#) [EAC-16-332-D](#) [EAC-16-472](#) [EAC-10-332-D](#) [EAC-10-472](#) [EAC-10-472-D](#)
[EAC-10-681](#) [EAC-10-681-D](#) [EAC-16-102](#) [EAC-06-681-D](#) [EAC-10-102](#) [EAC-10-102-D](#) [EAC-10-222](#) [EAC-10-222-D](#)
[EAC-10-332](#) [EAC-06-222-D](#) [EAC-06-332](#) [EAC-06-332-D](#) [EAC-06-472](#) [EAC-06-472-D](#) [EAC-06-681](#) [EAC-03-472-D](#)
[EAC-03-681](#) [EAC-03-681-D](#) [EAC-06-102](#) [EAC-06-102-D](#) [EAC-06-222](#) [EAC-03-102-D](#) [EAC-03-222](#) [EAC-03-222-D](#)
[EAC-03-332](#) [EAC-03-332-D](#) [EAC-03-472](#) [EAC-03-102](#)