

THIS DRAWING IS UNPUBLISHED. RELEASED FOR PUBLICATION
 © COPYRIGHT BY TYCO ELECTRONICS CORPORATION. ALL RIGHTS RESERVED.

LOC	DIST	REVISIONS			
P	LTR	DESCRIPTION	DATE	DWN	APVD
AJ	17	C	REVISED PER EC OS14-0016-05	27JAN05	BM KW

1. TAPE, REEL, AND TAPING SHALL MEET THE REQUIREMENTS OF EIA-481-1.
 2. EMBOSSED TAPE SHALL BE CONDUCTIVE TYPE.
 3. FOR PART ORIENTATION IN TAPE SEE DETAIL A.
 4. REEL SHALL CONTAIN 2500 PIECES.
- 5 REEL IDENTIFICATION LABEL SHALL BE PRINTED WITH REEL P/N, MANUFACTURER, QTY, AND TAPING DATE AS A MINIMUM.

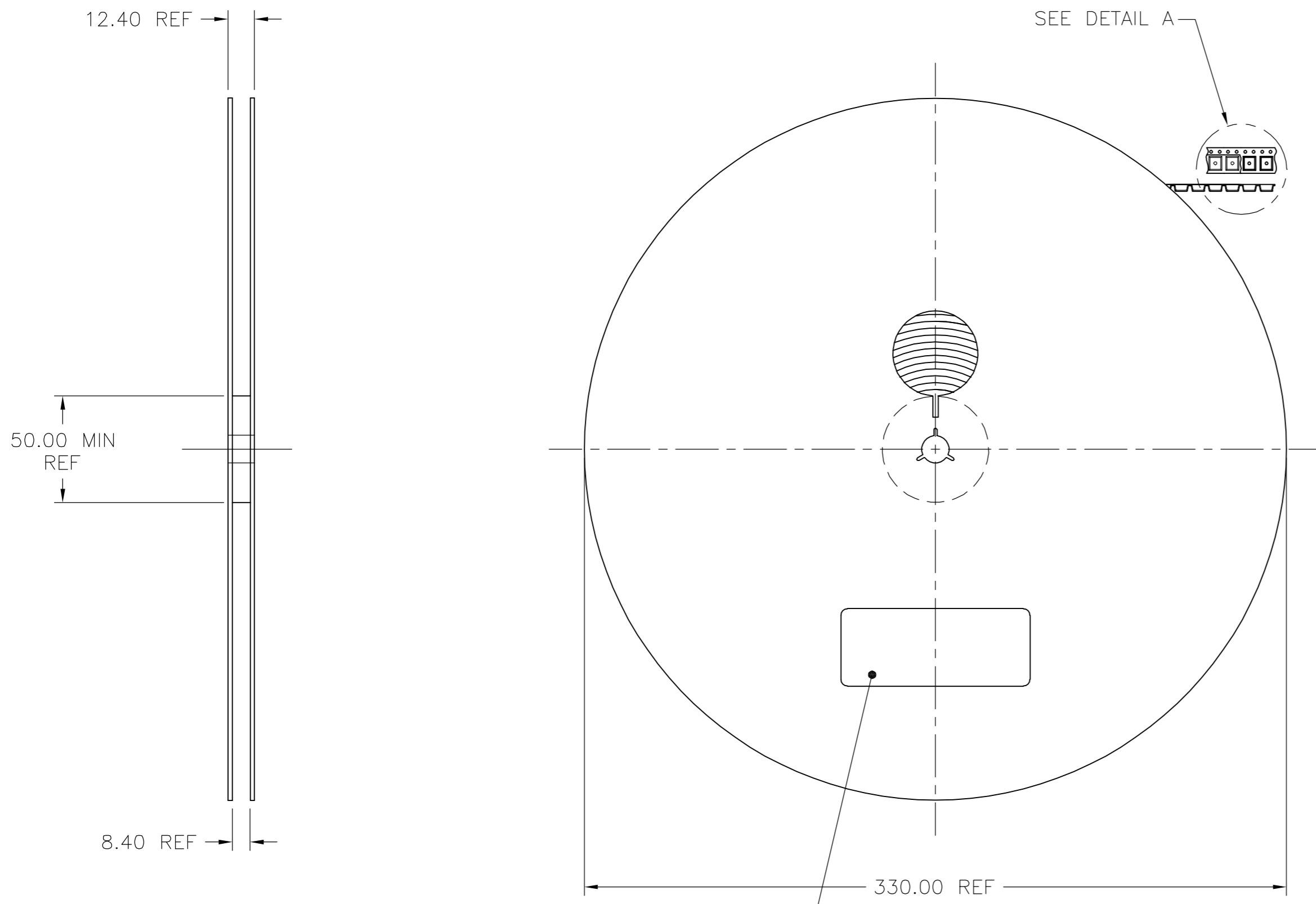

TAPE NOT SHOWN IN THIS VIEW FOR CLARITY

5 REEL IDENTIFICATION LABEL REF

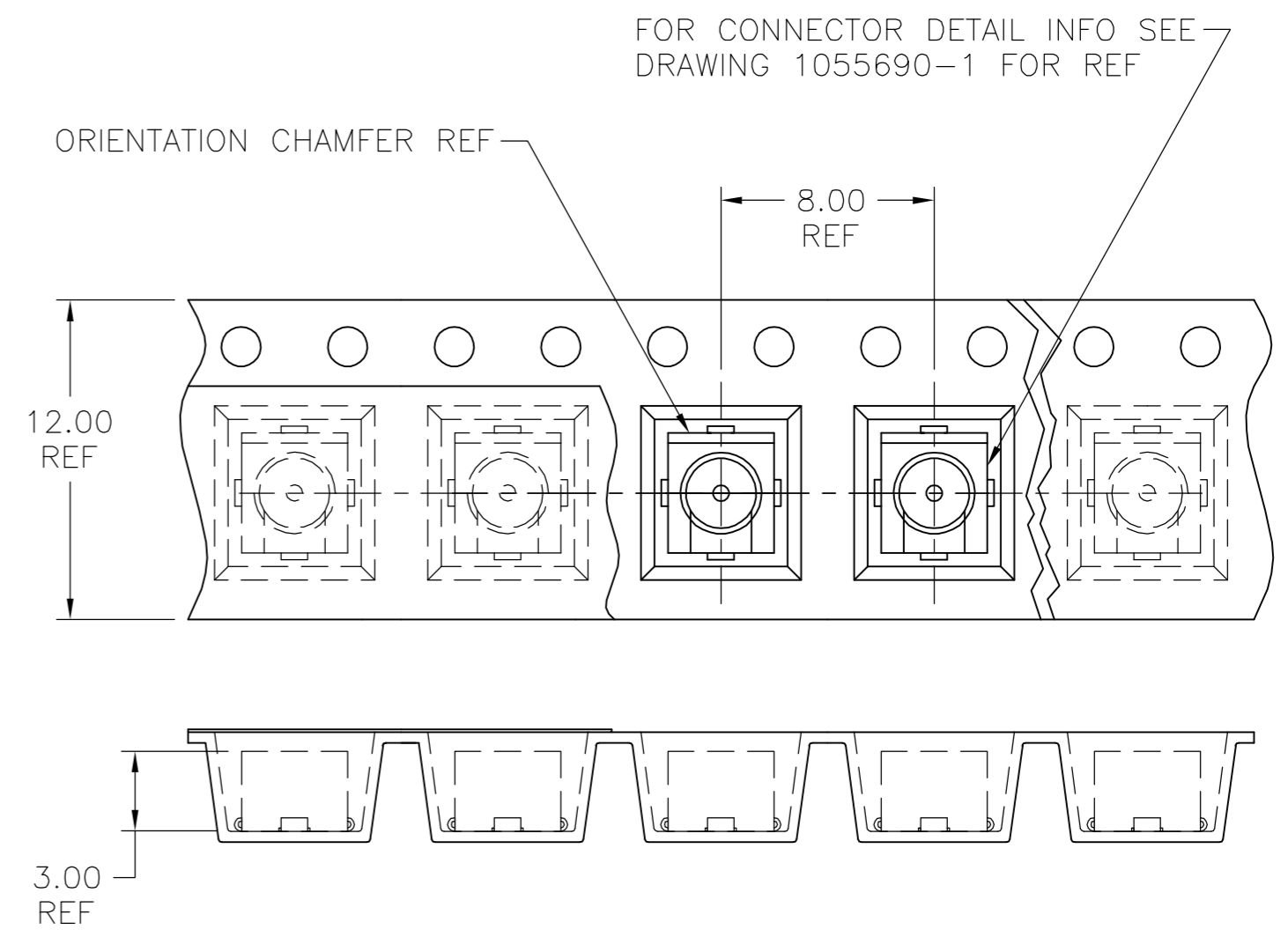

DETAIL A
SCALE 4:1

1055692-1
PART NUMBER

THIS DRAWING IS A CONTROLLED DOCUMENT.		DWN <i>PCV</i> 6/3/94	tyco Tyco Electronics Corporation	
DIMENSIONS: mm [INCHES]		CHK	Harrisburg, Pa 17105-3608	
TOLERANCES UNLESS OTHERWISE SPECIFIED:		APVD <i>PCV</i> 10/12/94	NAME	
0 PLC ± -	1 PLC ± -	PRODUCT SPEC	TAPE AND REEL PACKAGING, OSMT	
2 PLC ± -	3 PLC ± -	APPLICATION SPEC	PLUG, 330mm REEL(2500 PARTS PER REEL)	
4 PLC ± -	ANGLES ± -	WEIGHT	SIZE	RESTRICTED TO
MATERIAL	FINISH	WEIGHT	CAGE CODE	DRAWING NO
-	-	-	A2 00779	C=1055692
CUSTOMER DRAWING			SCALE 1/2:1	SHEET 1 OF 2

THIS DRAWING IS UNPUBLISHED. RELEASED FOR PUBLICATION
 © COPYRIGHT BY TYCO ELECTRONICS CORPORATION. ALL RIGHTS RESERVED.

LOC	DIST	REVISIONS			
P	LTR	DESCRIPTION	DATE	DWN	APVD
AJ	17	SEE SHEET 1	-	-	-

NOTES (FOR PCB LAYOUT ONLY):

- PRINTED WIRING BOARD MATERIAL: GLASS EPOXY. FR-4 OR SIMILAR, RELATIVE PERMITTIVITY: 4.8oz. COPPER CLAD BOTH SIDES.
- △ THESE DIMENSIONS VALID FOR 1.60[.062] BOARD THICKNESS.

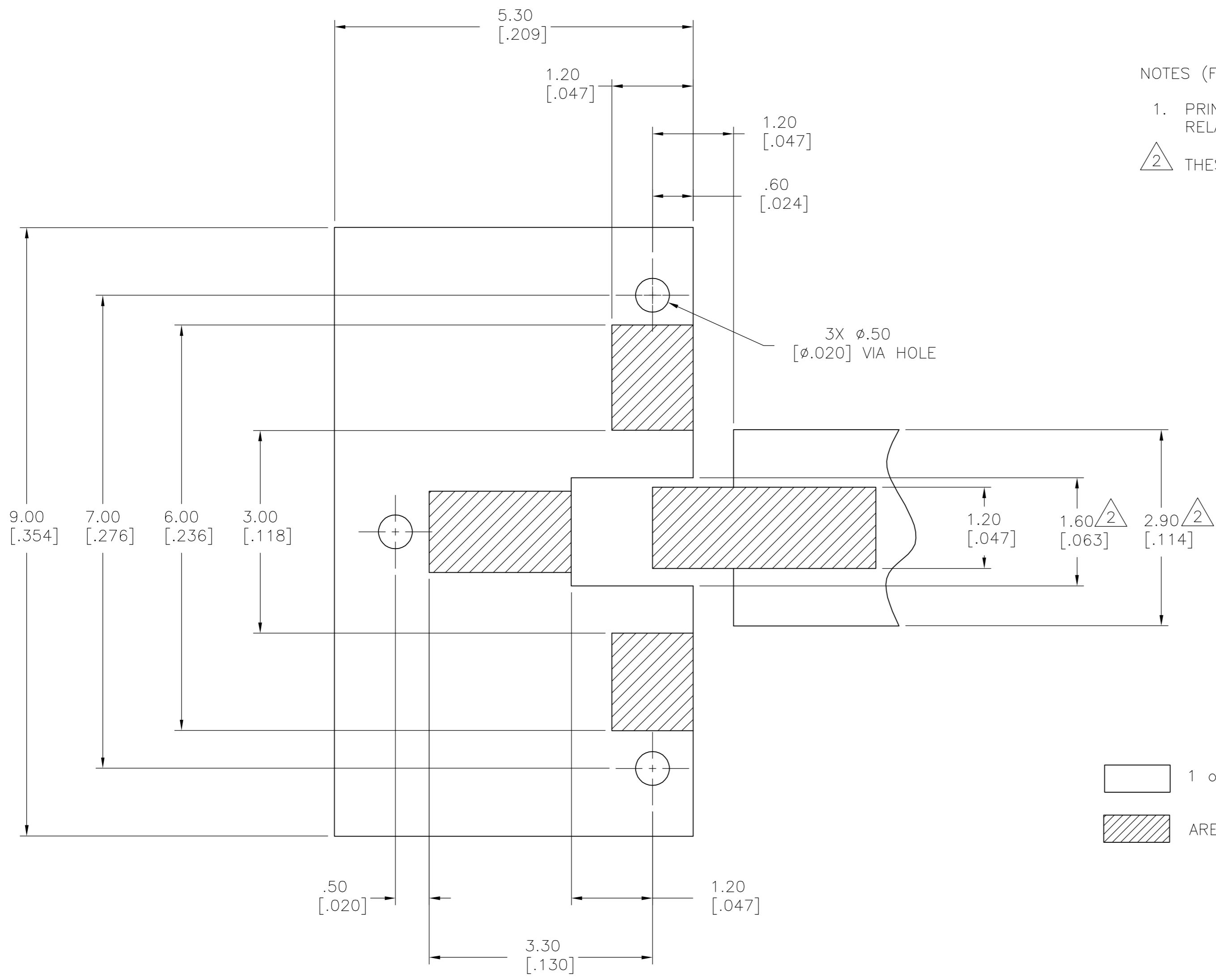

1 oz.[.0014] COPPER
 AREA FREE OF SOLDER MASK

RECOMMENDED MOUNTING PATTERN FOR MICROSTRIP LINE

THIS DRAWING IS A CONTROLLED DOCUMENT.		DWN <i>POV</i> 6/3/94	tyco Tyco Electronics Corporation	
DIMENSIONS: mm[INCHES]		CHK	Harrisburg, Pa 17105-3608	
TOLERANCES UNLESS OTHERWISE SPECIFIED:		APVD <i>POV</i> 10/12/94	NAME TAPE AND REEL PACKAGING, OSMT	
0 PLC ± -		PRODUCT SPEC	PLUG, 330mm REEL(2500 PARTS PER REEL)	
1 PLC ± -		APPLICATION SPEC	SIZE A2	CAGE CODE 00779
2 PLC ± -		WEIGHT -	DRAWING NO C=1055692	RESTRICTED TO -
3 PLC ± -		CUSTOMER DRAWING	SCALE 20:1	SHEET 2 OF 2
4 PLC ± -				REV C
ANGLES ± -				
FINISH -				

Mouser Electronics

Authorized Distributor

Click to View Pricing, Inventory, Delivery & Lifecycle Information:

[TE Connectivity:](#)

[2367-5016-54](#)